

# HORNS

## CONTENTS

	page		page
DIAGNOSIS .....	2	SERVICE PROCEDURES .....	3
GENERAL INFORMATION .....	1	SPECIFICATIONS .....	5

## GENERAL INFORMATION

Following are general descriptions of the major components in the XJ (Cherokee)/YJ (Wrangler) horn systems. Refer to Group 8W - Wiring Diagrams for complete circuit descriptions and diagrams.

### HORN SWITCH

#### XJ

Two horn switches are installed in the steering wheel, one on each side of the center-mounted driver's airbag module. When either switch is depressed it completes a circuit to ground for the coil side of the horn relay. The steering wheel and steering column must be properly grounded for the horn switches to function. The horn switches are only serviced as a set with their wiring. If either switch should fail, both switches must be replaced.

#### YJ

A single switch is installed in the center of the steering wheel, directly under the horn button. When the horn button is depressed the switch completes a circuit to ground for the coil side of the horn relay. The steering wheel and steering column must be properly grounded for the horn switch to function. The horn switch is available for service.

### HORN RELAY

On XJ models, the horn relay is a mini-relay installed in the relay center, which is mounted to the lower instrument panel reinforcement inboard of the

steering column. On YJ models, the horn relay is a ISO relay installed in the Power Distribution Center (PDC) near the battery tray. Refer to underside of PDC cover for relay identification.

One side of the horn relay electromagnetic coil receives battery voltage at all times. When a horn switch is depressed, the other side of the relay coil is grounded. The energized relay coil causes the normally open relay contacts to close, providing battery voltage to the horn.

If a problem is encountered with a continuously sounding horn, it can usually be quickly resolved by removing the horn relay until further diagnosis is completed.

### HORNS

On YJ models, a standard single, low-note, diaphragm-type horn is mounted and grounded to the left inner fender shield under the hood. Dual horns are standard equipment on XJ models. The high-note diaphragm-type horn is mounted and grounded to the left radiator closure panel brace behind the front bumper. The low-note diaphragm-type horn is connected in parallel with the high-note horn and is mounted and grounded to the right radiator closure panel brace behind the front bumper.

**On XJ models, a cadmium-plated screw is used to attach the horns to the body. Do not substitute other types of screws as they may become corroded and cause a loss of ground.**

DIAGNOSIS

**WARNING: ON VEHICLES EQUIPPED WITH AN AIRBAG, REFER TO GROUP 8M - RESTRAINT SYSTEMS BEFORE ATTEMPTING STEERING WHEEL COMPONENT DIAGNOSIS OR SERVICE. FAILURE TO TAKE PROPER PRECAUTIONS COULD RESULT IN ACCIDENTAL AIRBAG DEPLOYMENT AND POSSIBLE PERSONAL INJURY.**

(1) Inspect fuses (F8 and F16 in PDC on YJ)(11 in fuseblock module and F14 in PDC on XJ). Replace fuses, as required.

(2) Remove the horn relay (in the PDC on YJ)(in the relay center on XJ). See Horn Relay Connections-XJ (Fig. 1) or Horn Relay Connections-YJ (Fig. 2) and perform the following tests.

- The common feed terminal (30) is connected to battery voltage and should be hot at all times. If battery voltage is not present at relay cavity 30, check circuit to fuse (F16 on YJ)(11 on XJ). Repair as required.

- The normally closed terminal (87A) is connected to terminal 30 in the de-energized position, but is not used for this application.

- The normally open terminal (87) is connected to the common feed terminal (30) in the energized position. This terminal supplies battery voltage to the horn. There should be continuity between relay cavity 87 and the horn terminal at all times. If not, repair wiring or connections as required.

- The coil battery terminal (86) is connected to the electromagnet in the relay, and battery voltage should be present at all times. If battery voltage is not present at relay cavity 86, check circuit to fuse (F16 on YJ)(11 on XJ). Repair as required.

- The coil ground terminal (85) is connected to the electromagnet in the relay. It is grounded when the horn switch is depressed. Check for continuity to ground at relay cavity 85 with the horn switch depressed. If no continuity is found with horn switch depressed or, if continuity is found with horn switch released, repair horn switch or wiring as required. See Horn Switch Remove/Install in this group for service procedures.

If all relay connections check OK, proceed to next step.

(3) With the horn relay still removed, check the horn relay by performing the following tests.

- A relay in the de-energized position should have continuity between terminal 87A and terminal 30, and no continuity between terminal 87 and terminal 30.

- Resistance value between terminals 85 and 86 (electromagnet) is  $75 \pm 5$  ohms.

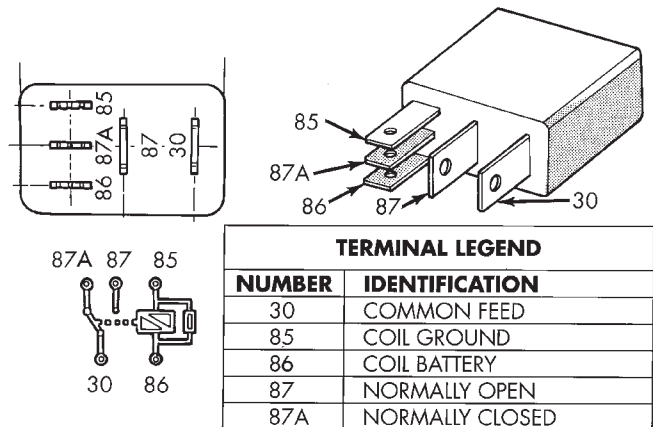

9514-16

**Fig. 1 Horn Relay Connections-XJ**

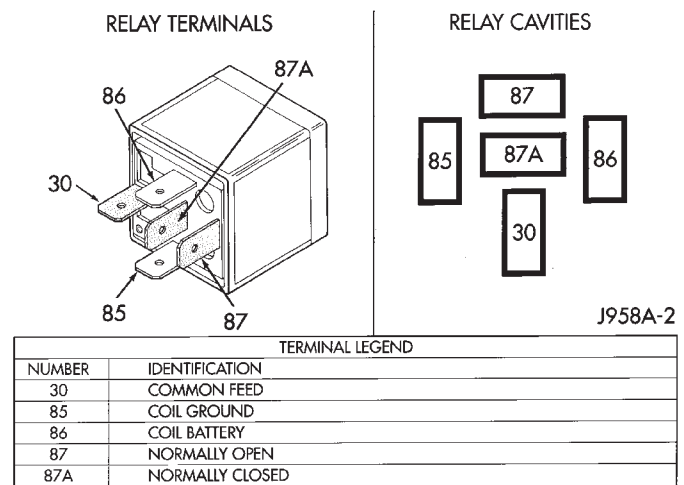

J958A-2

**Fig. 2 Horn Relay Connections-YJ**

- Connect a battery to terminals 85 and 86. There should now be continuity between terminal 87 and terminal 30.

If relay fails any of the above tests, replace faulty relay. If relay checks OK, reinstall and proceed to next step.

(4) Disconnect wiring at horn terminal. Depress horn switch. There should be battery voltage at the horn wiring connector. If not, repair wiring to relay. If OK, proceed to next step.

(5) Measure the resistance between the horn bracket and a good chassis ground. The meter should read zero ohms. If not, clean and tighten ground connection between horn mounting screw and bracket. If OK, replace faulty horn(s).

## SERVICE PROCEDURES

## HORN REMOVE/INSTALL

XJ

- (1) Raise and support the vehicle.
- (2) Remove the front underbody splash shield.
- (3) Remove horn mounting bolt and horn (Fig. 3).

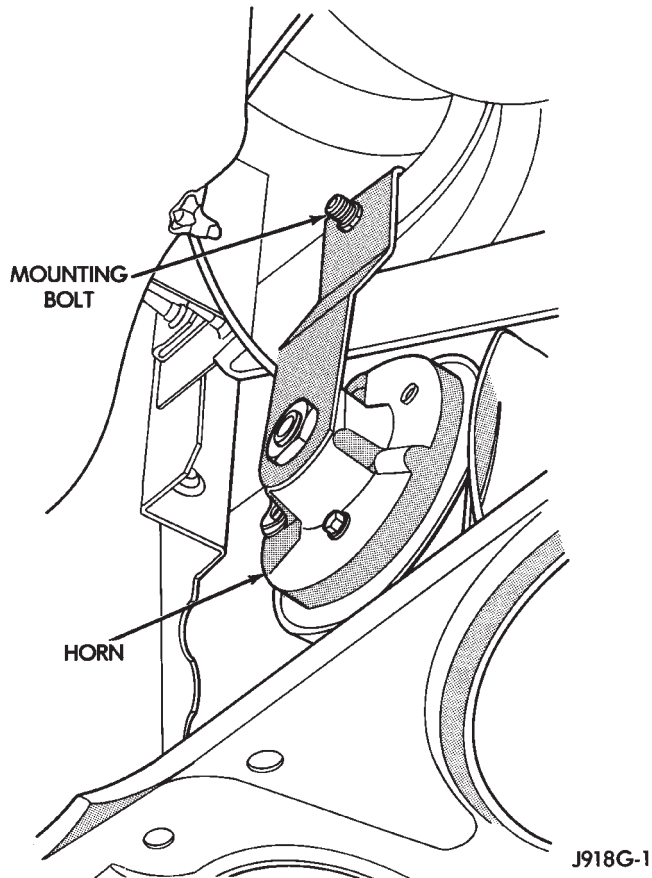

**Fig. 3 Horn Mounting - XJ**

- (4) Remove wire from horn.
- (5) Reverse removal procedures to install.

YJ

- (1) Disconnect wire harness connector from the horn (Fig. 4).
- (2) Remove horn and bracket mounting bolt. Horn and bracket are removed as an assembly.
- (3) Reverse removal procedures to install.

## HORN SWITCH REMOVE/INSTALL

**WARNING: ON VEHICLES EQUIPPED WITH AN AIRBAG, REFER TO GROUP 8M - RESTRAINT SYSTEMS BEFORE ATTEMPTING STEERING WHEEL COMPONENT DIAGNOSIS OR SERVICE. FAILURE TO TAKE PROPER PRECAUTIONS COULD RESULT IN ACCIDENTAL AIRBAG DEPLOYMENT AND POSSIBLE PERSONAL INJURY.**

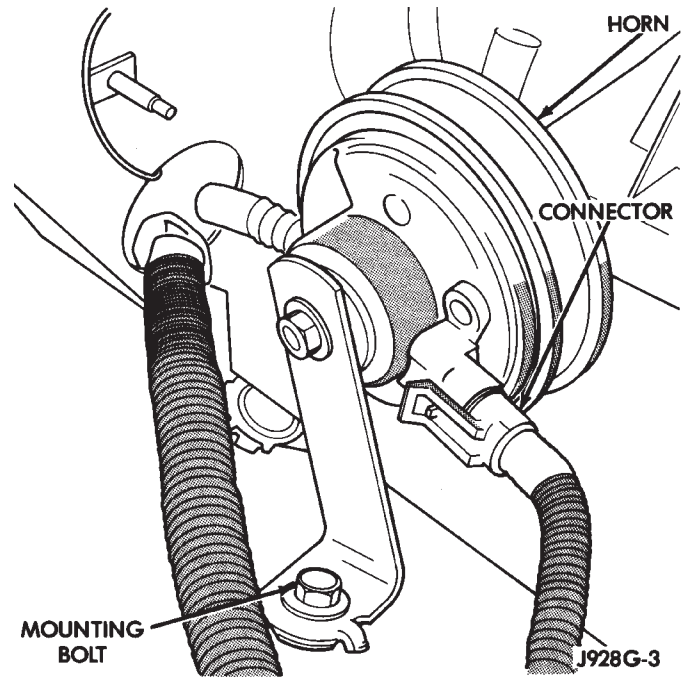

**Fig. 4 Horn Mounting - YJ**

XJ

- (1) Disconnect negative cable from battery and isolate.
- (2) Using a small screwdriver, remove plastic cover plug from top outer surface of steering wheel hub (Fig. 5). Exit vehicle and disarm airbag by reaching through driver's side window and turning arming screw counter-clockwise to its travel limit. This is done using an 8mm socket and manual drive. **DO NOT USE POWER-DRIVEN TOOLS.**
- (3) From back side of steering wheel, remove 4 nuts attaching airbag module to steering wheel. This is done using a 10mm socket and manual drive. **DO NOT USE POWER-DRIVEN TOOLS.**
- (4) Remove airbag module from steering wheel.
- (5) To access horn switch retaining screws, pry out trim cover buttons on back of steering wheel spokes directly behind horn switches. Remove retaining screws.
- (6) Disconnect horn switch wires located in the lower portion of steering wheel hub cavity and remove switches from steering wheel.
- (7) Reverse removal procedures to install. Tighten hardware as follows:

- airbag module nuts - 9 to 11 N·m (80 to 100 in. lbs.)
- airbag arming screw - not to exceed 1 to 1.5 N·m (10 to 15 in. lbs.).

YJ

- (1) Disconnect negative cable from battery.
- (2) Remove horn button by pulling straight up.

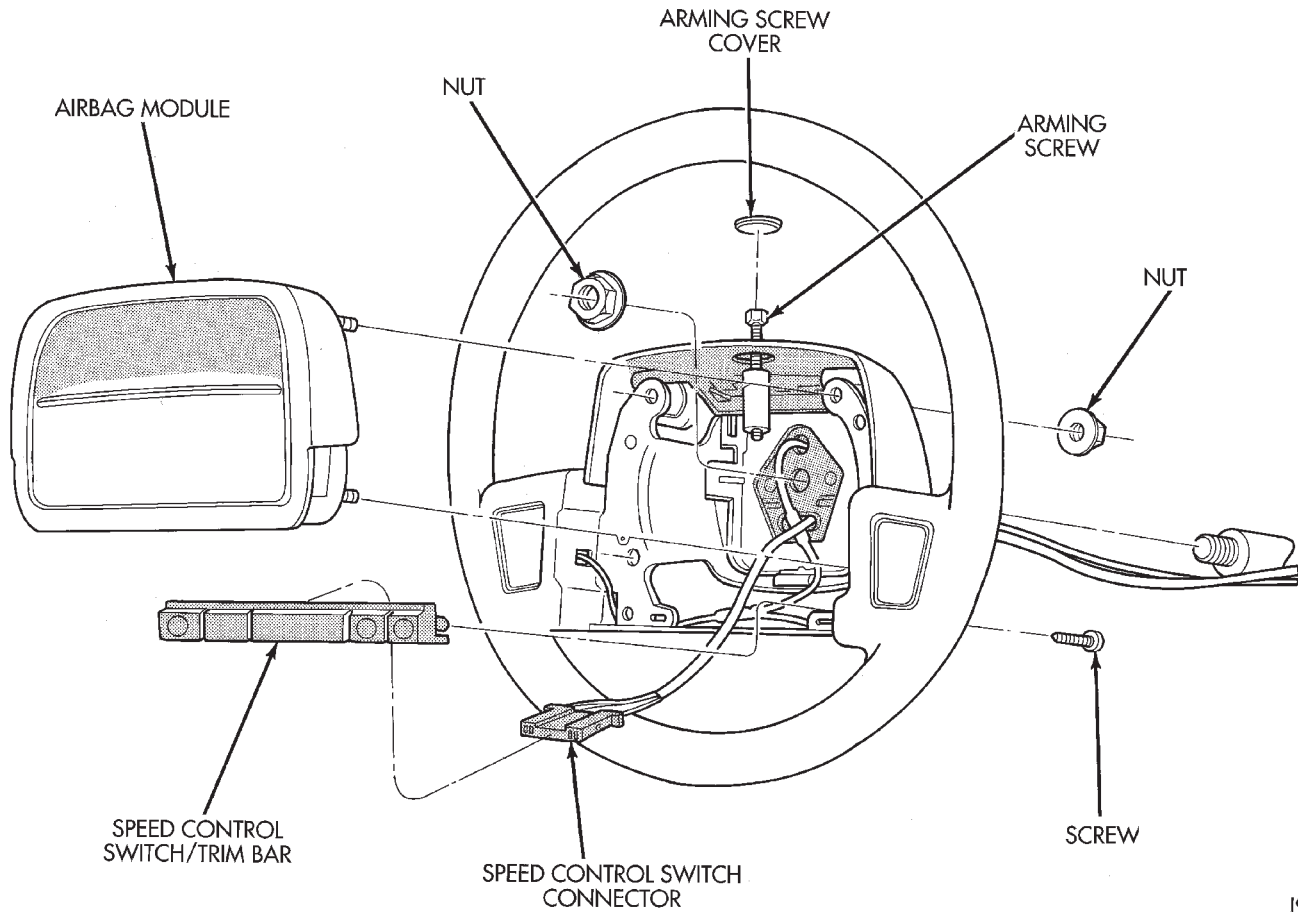

J958M-3

**Fig. 5 Airbag Module Remove/Install**

- (3) Remove horn button components (Fig. 6).
- (4) Reverse removal procedures to install.
- (5) Connect negative cable to battery.

**HORN CONTACT/CLOCKSPRING**

Refer to Group 19 - Steering for information on service of the horn switch contact (YJ) or clockspring (XJ).

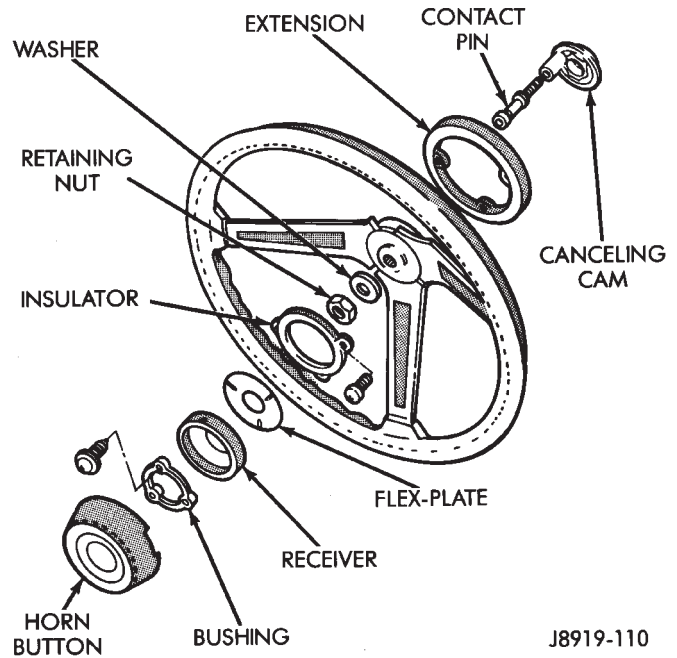

J8919-110

**Fig. 6 Horn Switch Remove/Install - YJ**

SPECIFICATIONS

<b>COMPONENT</b>	<b>TORQUE</b>
Horn Bracket Screw	20 N·m (15 ft. lbs.)

J918G-4

