

# INSTRUMENT HANDBOOK

Applicable to Serial No. *7.5.4.44*

MODEL bwd 539A

5" DUAL TRACE OSCILLOSCOPE

<u>SECTION</u>	<u>PAGE</u>	<u>CONTENTS</u>
1	1	GENERAL
2	1	SPECIFICATION
3	3	FUNCTION OF CONTROLS
4	6	FIRST TIME OPERATION AND APPLICATION NOTES.
5	10	CIRCUIT DESCRIPTION
6	16	ALIGNMENT PROCEDURE
7	21	REPLACEMENT PARTS
8	21	WARRANTY
9		PARTS LIST AND CIRCUIT

B.W.D. ELECTRONICS PTY. LTD.  
331 - 333 BURKE ROAD, GARDINER,  
VICTORIA, 3146, AUSTRALIA.

Telephone: 25-4425

B.W.D. ELECTRONICS PTY. LTD.,  
127 BLUES POINT ROAD, NTH SYDNEY  
NEW SOUTH WALES, 2060, AUSTRALIA

Telephone: 929-7452

# A GUIDE TO THE CHARACTERISTICS & METHODS OF SPECIFYING BWD OSCILLOSCOPES

## 1. VERTICAL AMPLIFIER(s)

### 1a. Bandwidth, Typical Spec.

DC or 2Hz to 10MHz -3db referred to 4 cm deflection at 50kHz.

#### Method of Measurement

Attenuator set to maximum sensitivity. (Below 5mV where noise may be present, the attenuator is set a decade back, i.e. 50mV in lieu of 5mV). Vernier, if incorporated set to CAL. Time base at 100 $\mu$ Sec and switched to AUTO.

A low distortion sine wave oscillator with an accurately monitored output (at the point of termination) or one with less than 1% change in level is coupled to the input-socket and correctly terminated. Frequency is set to 50kHz and input level adjusted for 4 cm peak to peak deflection.

The oscillator frequency is now increased and the level noted until it drops to 2.84 cms = -3db or 0.707 of the original level. This will be at 10MHz or higher.

If reference level is 5 or 6 cm etc. then input should be set to this level and -3db point is reached when deflection falls by 30%, i.e. 3.5 cm for 5 cm and 4.2 cm for 6 cm.

NOTE : It does not mean a 3db increase in the signal input will return the display back to 4 cm. This is due to inherent limitations in output amplifier deflection capabilities which largely determine the oscilloscope bandwidth.

Oscilloscope amplifier characteristics to note are : -

- (i) The response starts to fall around 30% of the bandwidth, i.e. a -3db 10MHz amplifier starts to roll off around 3MHz and,
- (ii) Full screen deflection is not normally available at the maximum bandwidth.

In low cost instruments it is available to approx. 50% of the bandwidth, i.e. up to 5MHz in a 10MHz oscilloscope, but in high performance and relatively high cost models it is available to over 80% of the bandwidth. Overdrive will produce a triangulated sine wave when deflection limit is reached.

### 1b. Low Frequency Response

With the input switched to DC, the amplifier response is constant (flat) down to zero frequency, enabling the oscilloscope to be used as a DC voltmeter. If the input is changed to AC, a capacitor (usual 0.1 $\mu$ F) is placed in series with the input removing the DC component and attenuating the low frequency AC signal. At 2Hz is slightly less than -3db down from the reference level. Square waves display sloping faces below about 200Hz. A 10-1 divider probe will extend this frequency response down by a factor of 10, i.e. -3db at 0.2Hz.

### 1c. Rise Time, Typical Spec.

35nSec over 4 cm.

#### Method of Measurement

This is most accurately obtained by interpolation. The formula, based on a step response

with less than 2% overshoot or ringing and applicable to all BWD oscilloscopes is rise time  
$$= \frac{350}{\text{bandwidth } (-3\text{db})} \text{ nano Sec. e.g. } \frac{350}{10} = 35\text{nSec.}$$

A measured rise time on an oscilloscope must also accommodate the input pulse rise time. The formula for this is  $t_{\text{display}} = \sqrt{t_{\text{pulse}}^2 + t_{\text{oscilloscope}}^2}$ . The accompanying chart on page 4C provides direct read-out of the values.

NOTE : When measuring near the upper limit of oscilloscope pulse, amplitude should be contained within the limit of the bandwidth reference level, (e.g. 4cm from above example) for greatest accuracy of rise time.

#### 1d. Input Impedance

This invariably consists of a  $1\text{M}\Omega$  resistance in parallel with a capacitive component. As the capacitance consists of strays and valve or F.E.T. input capacitance it is measured with the instrument working by a direct reading capacitance meter. In high sensitivity instruments an overvoltage applied by the meter can operate the protection circuits and change the input capacitance reading, so measurements are made at  $100\text{mV/cm}$ .

NOTE : As input capacitance is added to lead capacitance when making direct measurements, it is always recommended a  $\div 10$  high impedance probe be used to reduce this capacitive component down to  $10\text{-}12\text{pf}$  where signal levels permit.

### 2. HORIZONTAL AMPLIFIER

General Specifications and measurement techniques are similar to vertical amplifiers and will be referred to where applicable.

#### 2a. Bandwidth, Typical Spec.

DC to  $750\text{kHz}$   $-3\text{db}$  referred to 6 cm at  $50\text{kHz}$  at max. gain.

#### Method of Measurement

Horizontal gain vernier turned fully clockwise or switched as applicable to max. gain, spot centered.  $50\text{kHz}$  sine wave is coupled in and set to 6 cm deflection. Increase input frequency until trace width drops to  $4.2\text{cm}$ ; this is the  $-3\text{db}$  point. All notes relative to vertical amplifier section should also be applied to this section, i.e. max. deflection, roll off, rise time etc.

#### 2b. Input Impedance

Many horizontal input amplifiers are transistors with a relative low input impedance, therefore input specifications vary widely from  $56\text{K}\Omega$  to  $1\text{M}\Omega$ , and capacitance varies from  $10\text{pf}$  to  $50\text{pf}$ . Input capacitance and resistance is measured at max. gain.

### 3. TIME BASE

This section is divided into the following sections : -

(i) Time Base; (ii) Magnification; (iii) Triggering;

#### 3a. Time Base, Typical Spec.

$200\text{nSec}$  to 2 Sec in 22 steps, calibration  $< 3\%$ .

#### Method of Measurement

Set time base to  $1\text{mSec}$  and vernier fully clockwise to CAL. Feed in a  $1\text{kHz}$  square wave or pulse with better than  $0.1\%$  frequency accuracy. When the first pulse is lined

up with the first graticule line, then the 10th pulse should be within  $\pm 3$  mm of the 10th graticule line, Checks made at all other time base steps with corresponding calibration pulses should be within the same limits.

**NOTE :** Calibration accuracy is not the accuracy of each individual division (unless specifically stated) but the overall accuracy, where any variation in trace linearity is averaged over the 10 div. (cm) deflection.

Where linearity is specified, it is usually measured between the 1st and 9th graticule lines to eliminate compression effects around the perimeter of the CRT.

### 3b. Magnification, Typical Spec.

3% accuracy at X1 and 5% at X5 up to  $1\mu\text{Sec}/\text{cm}$ .

#### Method of Measurement

After calibration check as above at  $1\text{mSec}/\text{cm}$  trace is expanded to X5. 1kHz calibration pulses should be 5 cm apart  $\pm 2.5$  mm. With trace at X5, time base is increased to  $5\mu\text{Sec}/\text{cm}$  producing a  $1\mu\text{Sec}/\text{cm}$  magnified sweep. This is the limit of specified calibration although it is normally within spec. at X10 this sweep speed over most the trace length.

### 3c. Triggering, Typical Spec.

INT AUTO 1 cm defl. 5Hz to 10MHz.

This implies when the time base is adjusted for convenient viewing of input, i.e. 5-10 sine waves visible across screen 1 cm high irrespective of attenuator setting, the time base will present a stable display. Above a few MHz it may be necessary to select + or - slope to obtain greatest clarity of display.

**NOTE :** All bwd oscilloscopes incorporate an AUTO circuit which varies its rate as the time base range switch is changed, they also have a unique feature which increases the sensitivity of the time base if the trigger level drops at high frequencies - a feature which accounts for their superior triggering characteristics. At low frequencies the AUTO rate may exhibit an intermittent repetition rate. This is quite normal and in no way effects its excellent locking ability when a signal is present.

Typical Spec. Level Select  $\pm 3$  cm range 3Hz to 10MHz.

If the Select Control is turned clockwise from AUTO, the triggering point can be selected over a 6 cm range. At the upper and lower frequencies of the trigger range the level range reduces and becomes more critical to adjust.

**NOTE :** On oscilloscopes with DC coupled trigger (bwd 521, 522 and 525) time base trigger can be initiated by a change in the DC level of the displayed signal or any frequency down to zero with full selection of the trigger level.

Spec. EXT AUTO 1V P-P 5Hz to 10MHz.

EXT LEVEL SELECT  $\pm 5$  V P-P 3Hz to 10MHz.

Characteristics are as specified for internal trigger, but refer to an external trigger signal applied to the EXT trigger socket.

**NOTE :** Input levels to EXT trigger socket are often limited to  $\pm 60$ V or 100V RMS. Do not exceed these limits or failure of input transistor may result.

Z MODULATION Typical Spec. -20V to modulate at normal intensity.

Set T.B to  $1\text{mSec}/\text{cm}$ , feed in a 1kHz sine wave 20V P-P from low Z source. Trace should clearly change brightness level each cm.

# INSTRUMENT HANDBOOK

## MODEL bwd539A OSCILLOSCOPE

### 1. GENERAL

An oscilloscope that thoroughly commends itself for use in Research, Education or Servicing must be stable, have a high performance and be virtually self operating.

These are the characteristics you will find after a short time at the controls of this versatile Model bwd539A Dual Trace Oscilloscope.

The 100% silicon solid state design is extremely stable in operation, amplifier and time base are compensated against input line voltage changes both for sensitivity and positional movement. Input FET amplifiers are protected against both + and - input over-voltage conditions up to 400V peak.

An active T.V. sync circuit provides line or frame lock which permits viewing of individual frame pulses, colour burst or equalising pulses.

For additional versatility the sync separator also provides an HF reject trigger selection and a demodulated trigger waveform for stable viewing of A.M. or single sideband R.F. displays.

Application notes are contained in Section 4 of this handbook.

Model bwd 539 has been designed for reliable long-term use - it has been subjected to environmental tests and each instrument is heat soaked and vibrated as part of its alignment procedure.

For maximum reliability it is advisable to replace the power supply protection fuse every 2000 hours of operation to guard against thermal stress failure. Additionally, if the instrument is to be left non-operating for long periods and is stored in a dusty atmosphere, it is wise to drop a plastic protection cover over it to minimise dust ingress into switch wafers, etc. A storage cover and a carrying case are available from the supplier, together with a full range of accessories.

### 2. SPECIFICATION

2.1 <u>C.R.T.</u>	<u>Type</u>	5" Diameter Type D13 - 27GH incorporating a spiral PDA & DC coupled Beam blanking.
	<u>Phosphor</u>	P31 normally supplied. P7 available as Option 04.
	<u>EHT</u>	3.0kV.
	<u>Graticule</u>	8 x 10 cm. graticule with .2mm subdivisions on major axis on green light filter.
	<u>Deflection</u>	8 cm. vertically x 10 cm. horizontally.

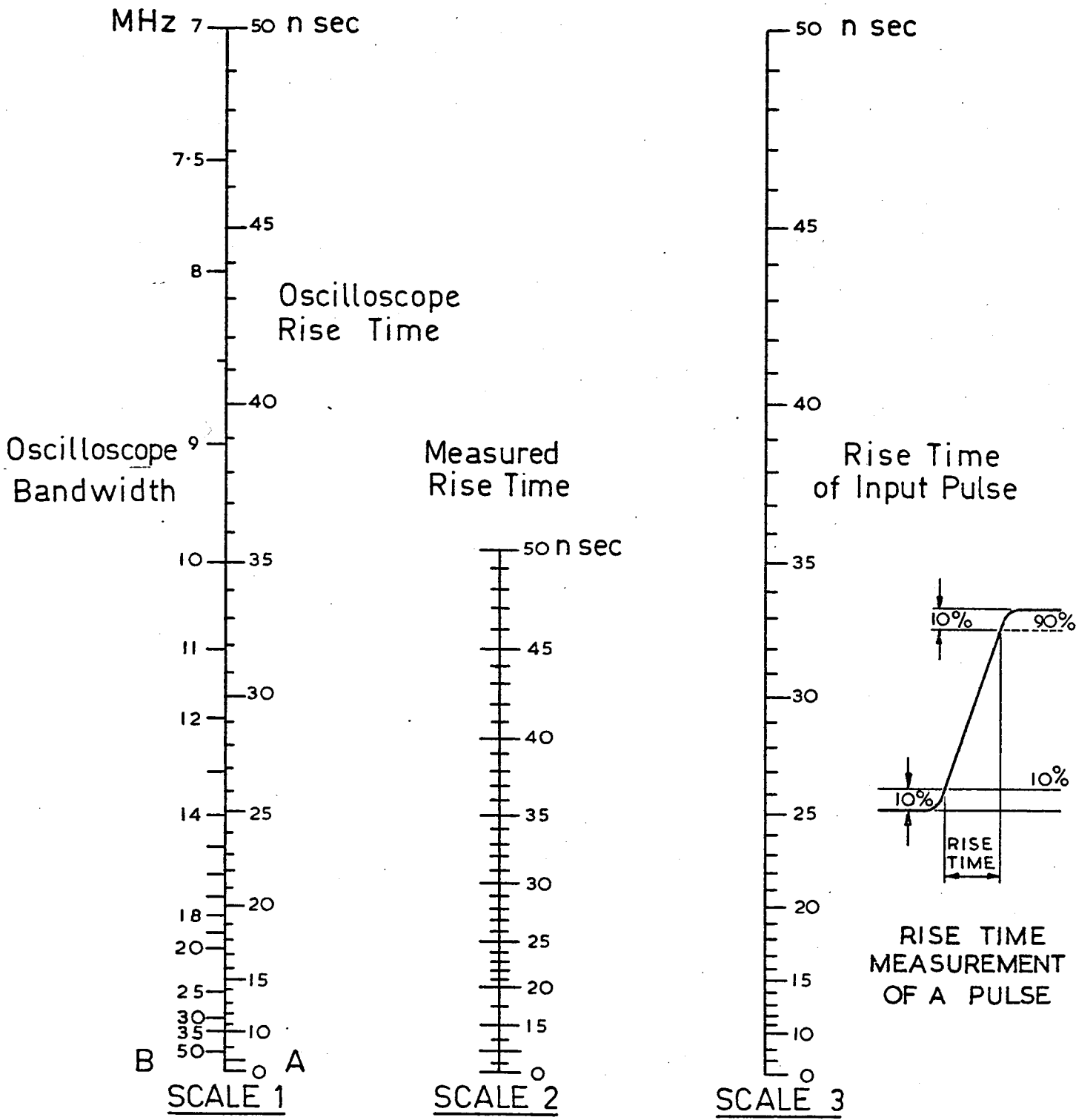

To use the above chart read the rise time of the displayed waveform on the CRT between its 10% and 90% points. Find the point corresponding to this value on Scale 2. Join this with a straight edge to the value corresponding to the oscilloscope bandwidth on Scale 1B, the projection on Scale 3 is the true rise time of the input pulse.

For other rise time ranges Scales 1A, 2 & 3 can be multiplied by a conversion factor, e.g. 2, 5 or 10. Scale 1B must be divided by the same factor.

## 2. SPECIFICATION (Cont'd)

### 2.2 VERTICAL AMPLIFIER (Channel A & B Identical)

<u>Sensitivity</u>	10mV to 50V per cm. in 12 direct reading steps in a 1,2,5, 10 Sequence.
<u>Bandwidth</u>	DC or 2Hz (AC coupled) to 10MHz-3db., referred to 4cm. deflection at 50kHz.
<u>Rise Time</u>	23nSec. for 4 cm. deflection.
<u>Input Impedance</u>	1m $\Omega$ and 40pf constant.
<u>Calibration</u>	<5% including 10% line change. Trace drift < $\pm$ 1cm.
<u>Deflection</u>	2 Screen diameters up to 1MHz.
<u>Input Voltage Protection</u>	$\pm$ 400V DC or 280V AC RMS.
<u>Display Mode</u>	Single beam Channel B Only chopped (100KHz) and alternate. Dual trace A & B chopped at 100kHz approx. A & B Alternate.
<u>Trace Divergence</u>	<2mm at centre screen on low time base speeds.

### 2.3 TIME BASE

<u>Range</u>	1 $\mu$ S to .5Sec/cm. in 18 switched ranges with 5-1 vernier extending range down to 2 Sec/cm. Calibration <5%.
<u>Magnification</u>	X1 to X5 continuously variable, calibration <5% at X1 and at X5 up to max. sweep speed of 1 $\mu$ Sec/cm.

### 2.4 TRIGGERING - Channel A or B by switch selection.

<u>Selection</u>	<u>Coupling</u>	<u>Slope</u>	<u>Source</u>	<u>Mode</u>
	Norm.	+	Int.	AUTO
	T.V.	-	Ext	Select Level
<u>Sensitivity</u>	Int. AUTO	1cm. defl. 2cm. defl.	5Hz to 5MHz 2.5Hz to >10MHz (+ve slope)	
	Int. Select	$\pm$ 3cm. max.	5Hz to >2MHz	
	Ext. AUTO	1V RMS	2.5Hz to >10MHz	
	Ext. Select	>1V RMS	2.5Hz to >5MHz	
			Max. Ext Input 100V p-p Max. or 30V RMS.	
<u>T.V. Sync.</u>	Triggers on-Line in AUTO position. Triggers on Frame with Trig Level fully clockwise.			
<u>Sensitivity</u>	2 cm. to over 8 cm. composite video waveform. Displays frame pulses, equalising pulses, colour burst, etc.			
<u>Demodulation or HF Reject.</u>	T.V. Selection also provides stable locking of modulated R.F. Waveforms and eliminates HF noise from trigger signals below 2kHz approx.			

### 3. FUNCTION OF CONTROLS (Cont'd)

#### 3.1 Cont'd.

± Switch                      Selects the positive (+) or negative (-) slope of the displayed signal or external trigger waveform to initiate the time base.

INT-EXT Switch              · Selects the trigger source from the displayed waveform on Channel A or B or an external waveform.

#### Vertical Position Channel A & B (Red Knobs)

Moves the traces up and down the C.R.T. Channel A position control also switches off Channel A when rotated fully anticlockwise until it operates the switch detent when single beam operation is required.

#### Volts/cm (Attenuator) Channel A & B

Switches adjust the sensitivity of the Vertical Amplifiers from 10mV per cm to 50V per cm in a 1,2,5,10 series of steps. Attenuator accuracy is 2% and the overall oscilloscope accuracy is within 5% on any step.

#### DC-AC Switches (Channel A & B)

In the DC position of this switch the amplifiers are directly coupled from input to output. In the AC position a capacitor is placed in series with the inputs to eliminate any DC component and attenuate all frequencies below 2Hz.

### 3.2 TERMINALS AND SOCKETS FRONT PANEL

Vertical Input                      Co-ax. Socket. A positive input will cause the trace to move upwards; a negative input will cause the trace to move downwards.

In Alt                                      )  
Out Chop                                ) Push Pull Switch

For time base speeds above 2mSec/cm, switch should be pushed to ALT position. Below 2mSec/cm use in chopped position to eliminate trace flicker between displays.

When Channel A is switched off for single beam operation, push switch into ALT position. For X-Y operation with external Time Base push to ALT for single beam operation and pull to CHOP for dual beam display.

Trig  
Select

Push-Push Switch  
Select A or B Trigger



## 2. SPECIFICATION (Cont'd)

### 2.5 HORIZONTAL AMPLIFIER

<u>Sensitivity</u>	Approx. .70V to approx. 10V/cm. continuously variable.
<u>Bandwidth</u>	DC to 1 MHz -3db.
<u>Input Impedance</u>	56K $\Omega$ and 10pf approx.
<u>Max. Input</u>	$\pm$ 160V or 60V rms.

### 2.6 Z MODULATION

Input to CRT grid. 0.01 $\mu$ F + 22K $\Omega$ . +30V required blank CRT at normal intensity

Calibrator Line Frequency 1V p-p square wave 2% accuracy.

Time Base Output 0 to 25V positive going sawtooth max. Load 22K $\Omega$  min.

Power Requirements 30 Watts approx. 85 V - 135V in 3 ranges } 50 - 60 Hz  
190 V - 265V in 3 ranges }

Dimensions 9.1/4" high x 7.1/2" wide x 16.1/2" deep overall feet, handle, knobs, etc.

Weight 16 lb. (7kg.) Domestic / Air Freight Pack: 17.3/4 lb. (8 kg.)  
Export Pack: 22 lb. (10 kg.).

#### Optional Accessories

Probes X1	P30
X1 & X10 Kit	P22A
X1, X10 and Demod.	P29
Demodulator	P35A
Carrying Case	C52
Vinyl Dust Cover	C12
Light Shield	H44
19" x 8.3/4" Rack Mount Adaptor	R77

NOTE: Characteristics expressed in numerical values with tolerances stated are guaranteed by the factory. Numerical values without tolerances represent the values of an average instrument. All data applies in case of nominal mains voltage unless otherwise stated.

## 3. FUNCTION OF CONTROLS

3.1 Front Panel controls are grouped for ease of use and are clearly designated. The functions of these controls are as detailed below -

Intensity Control Fully anti-clockwise, this control switches the instrument OFF. When rotated clockwise the instrument is switched ON and further rotation controls the trace intensity (brightness) from zero to max.

### 3. FUNCTION OF CONTROLS (Cont'd)

#### 3.2 TERMINALS AND SOCKETS FRONT PANEL (Cont'd)

##### X Input

When the Time Base Vernier is turned anti-clockwise to "T.B. OFF" signals may be fed into socket to produce a horizontal display, input is DC coupled. For AC coupled inputs an external capacitor must be placed in series with the lead. Max. Input is  $\pm 100V$  or  $60V$  AC.

##### CAL. 1V p-p

A 1V peak to peak square waveform is available to check the amplifier calibration, T.B. calibration, probe alignment or for use as an external signal.

##### Ext. Trigger

When the Trigger Selection switch is in the EXT position, signals from 1 to 20V will trigger the Time Base. Full selection of amplitude over a range of  $\pm 10V$  or AUTO operation with positive or negative and T.V. selection is available.

#### 3.3 REAR PANEL

##### Z Modulation

A 30V p-p square wave or a sine wave of 10V RMS or greater will blank the trace at normal intensity. Negative going signals blank the trace. Positive signals brighten the trace.

Time Base Output A 25V p-p sawtooth swinging approx. 0 to +25V to common is available at low impedance. Min. external loading 22K $\Omega$ .

### 4. FIRST TIME OPERATION

Check tapping on Power Transformer for correct connection for local supply mains. Instrument is fitted with universal primary for 100 to 240V operation, connect as shown below to suit local power line voltage.

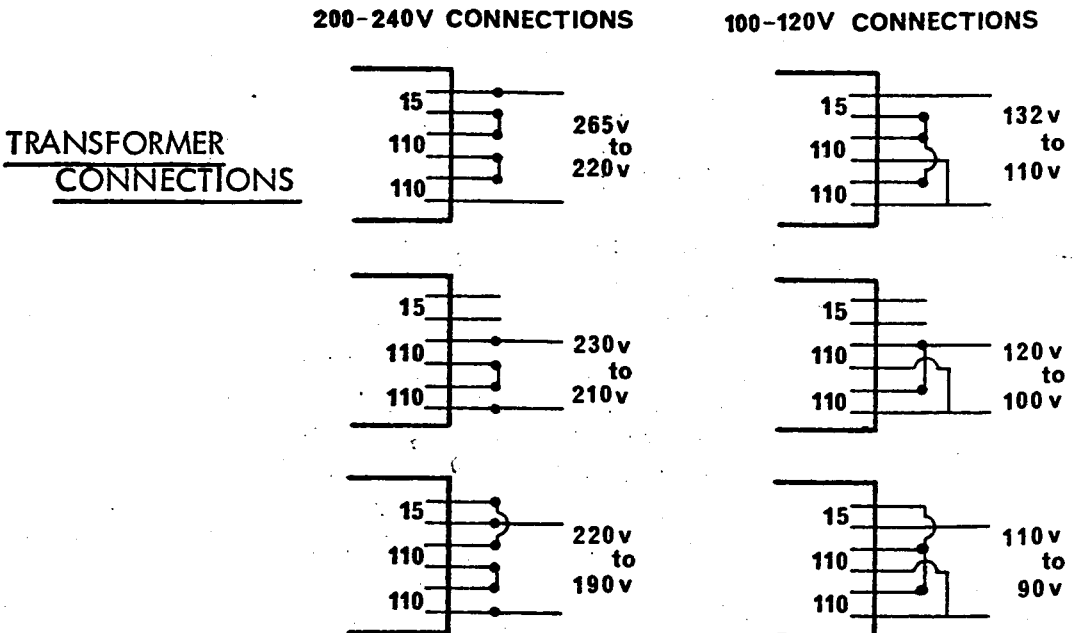

### 3. FUNCTION OF CONTROLS (Cont'd)

#### 3.1 Cont'd

Focus Controls the sharpness of the trace. May require a slight re-adjustment over the full intensity control range.

Astigmatism Preset rear panel control, adjusts beam for optimum shape over entire screen area.

Horiz. Position (Red Knob) moves the trace horizontally on the C.R.T.

Horiz. Mag (Grey Knob) when the Time Base is in use, this control varies the length of the trace from 10 cm. to 50 cm., providing X5 expansion. When an external Horizontal Input is used, the Horizontal Gain varies the sensitivity from .7V to approx. 10V per cm. approx.

#### Auto, Trigger Level Control

Fully anti-clockwise, and switched to the AUTO position, any signal greater than 0.5 cm. in amplitude will trigger the time base, however with no signal present, an Automatic trigger pulse is generated to produce a base line, the trigger rate increases as the Time Base Speed range increases, producing a bright reference line at all sweep speeds. When the knob is switched out of the AUTO position, it selects the Level on a displayed waveform of  $\pm 4$  cm. to trigger the Time Base.

#### T.B. Vernier (co-ax with Time/cm. Switch).

Varies the Time Base speed over a range greater than X5 to provide a continuously variable range in conjunction with the TIME/CM. switch of 2 Sec/cm. to 1 $\mu$ Sec/cm. When the VERNIER control is turned and switched fully anti-clockwise it switches off the internal Time Base permitting an external signal to be fed into the X INPUT socket.

#### Time/cm. (Time Base) Switch

When the Time Base Vernier control is fully clockwise in the CAL position, the 18 time base speeds on this control will be accurate to within 5%. The switch speeds represent the fastest speed on each range; rotation of the Time Base Vernier Control anti-clockwise will reduce the selected speed over a range greater than X5, e.g. on the 1mSec. range the Vernier will vary the time base from 1mSec. down to 5mSec/cm.

#### Norm - T.V. Switch

In Norm. position, triggering is controlled by + and - switch and trig. level control. In the T.V. position a sync separator is brought into circuit and the Trig Level control assumes dual function. In the AUTO position stable LINE lock is provided and when the control is turned fully clockwise very stable FRAME lock is obtained even from noisy video signals. See Section 4 for further details.

#### 4. FIRST TIME OPERATION (Cont'd).

##### 4.5 Cont'd

Increase the Vertical sensitivity by the VOLTS/CM switch until a display between 3 and say 8 cm. exists. Now adjust the Time Base Switch and Vernier to enable the waveform to be readily seen. To measure the amplitude of a displayed waveform, measure its overall height in cms. by the calibrated graticule, then multiply this by the attenuator setting and the result is in Volts p-p, e.g. if the display is 6 cm. high and the attenuator is set to 0.5V then the amplitude is  $6 \times 0.5 = 3V$  peak to peak, to convert to RMS voltage for sine waves, divide the 3V by 2.84, e.g.

$$\frac{3.00}{2.84} = 1.06V \text{ RMS}$$

The frequency of a waveform can be found by turning the Time Base Vernier to CAL (clockwise) then switch the TIME/CM switch to a range where the signal can be clearly seen, e.g. if a waveform is 5cm long and the switch is on 100uSec., then the duration of the waveform is  $5 \times 100\text{uSec.}$ . The frequency can be determined by dividing 1 Sec., i.e. 1,000,000uSec. by the duration of the waveform.

$$\frac{1,000,000}{500} = 2,000\text{Hz} = 2\text{kHz}$$

##### 4.6 CURRENT MEASUREMENTS AC OR DC.

Where it is possible to place a low value resistor in the earthy end of a circuit the current through this resistor can be found by viewing the voltage across it and converting it by ohms Law to current. By using a  $1\Omega$  resistor the attenuator calibrations read directly in mA or A in lieu of mV or W. When the oscilloscope is connected across it.

This will display AC or DC current and, unlike an ammeter, will show the actual current waveform. Practical applications are the charging currents in a filter capacitor of a power supply or the current through a rectifier via the centre tap of a transformer etc.

##### 4.7 MEASUREMENTS WITH AN EXTERNAL HORIZONTAL INPUT.

As the HORIZ. INPUT is directly coupled, the C.R.T. display can be used for X - Y plotting over an  $8 \times 10$  cm. area.

Switch to "T.B. OFF" and calibrate the Horizontal Amplifier by feeding in the CAL waveform and adjusting the HORIZ. MAG. until the display equals 1 cm. Set the Vertical Attenuator to 1V/cm. The oscilloscope has now identical X and Y sensitivities, of 1V p-p/cm. (Other sensitivities can be used with equal or unequal sensitivities as required).

Remove the CAL. waveform and centre the spot. Positive or negative voltages may be now applied to X and Y inputs and the result plotted on tracing paper placed over the C.R.T. or transferred to a ruled graph paper. AC signals will show phase displays or Lissajous figures. With the vertical input switched to DC less than  $2^\circ$  phase shift exists up to 10kHz and  $5^\circ$  at 20kHz between X and Y inputs. Dual trace displays can be obtained by pulling out the CHOP mode switch knob.

#### 4. FIRST TIME OPERATION. (Cont'd)

##### 4.1 Set controls as follows:-

Intensity	-	OFF (anticlockwise)
Focus	-	mid-position
<u>Amplifiers A &amp; B</u>		
Attenuator	-	.2V/cm.
Vert. Position	-	mid-position
Input Selectors	-	AC
Alt-Chop Switch	-	Chop (pulled out).
<u>Time Base.</u>		
Time Base Range	-	10mSec/cm.
Vernier	-	Clockwise (Cal).
Trigger Level	-	AUTO (anticlockwise)
± Select	-	+
NORM - T.V.	-	NORM
INT-EXT.	-	INT
HOR. MAG	-	Anti-Clockwise X1
HOR. POSITION	-	Mid-position

- 4.2 Connect instrument to power mains, (check transformer tapping as in 4.1) then switch instrument on. After about 10 seconds when traces appear, adjust beam for suitable intensity and sharp focus. Now position traces centrally across screen. Connect a lead from the CAL socket to the 'B Channel' input socket. A 50Hz square wave will be displayed with the top and bottom faces of the waveform sloping. Switch the input selector to DC. The square wave will be displayed positive going to the base line. Recentre with position control. Adjust Time Base range switch and vernier to check characteristics with two waveforms displayed, change over ± trigger selector switch. Turn the Level Selector control clockwise. This switches off AUTO, the trace will disappear then re-appear as control is rotated and the point at which the trace is initiated will move up or down the edge of the waveform as selected by the ± selector. It will disappear when almost fully clockwise.

Return the control to AUTO and adjust the TIME/CM switch to give five waveforms across the CRT, then turn the HORIZ. MAG control clockwise until one waveform is 10 cm. long; this illustrates the trace expansion facility. If the horizontal position is turned the trace can be tracked along to view any part of it from one end to the other.

To check the X INPUT, turn the T.B. Vernier to T.B. OFF. Connect a lead from the CAL socket to the X INPUT socket, a horizontal line will appear whose length can be varied by the HORIZ. MAG control from 1 cm. down to less than .2 cm. The Horizontal position of the trace can be set by the HORIZ. POSITION control.

Instead of the CAL waveform connect an audio oscillator (e.g. Models 140A, 112B or 602) to Channel 'B' input. Set input frequency to 1kHz - increase Time Base speed and note how in the Chopped mode, the individual chopped segments of the waveform appear. Push the switch in to the Alternate position. The chopping

#### 4.8 TELEVISION WAVEFORM DISPLAYS.

Very stable displays of frame or line signals may be obtained by switching trigger coupling to T.V. With a positive video waveform displayed select T.V. and +, if video is negative going - video signal not sync, then select - ve.

To lock the signal to line frequency set the TRIG. LEVEL to AUTO (Line) then turn TIME/CM. switch to view line waveform. To lock signal to frame frequency rotate the TRIG. LEVEL fully clockwise and adjust T.B. speed to view one or two frames as required. Detailed examination of the frame pulse and following equalising pulses etc. can be made by increasing time base speed and/or using the X5 expansion. As the repetition rate is only 50Hz or 60Hz, the trace intensity falls with increasing time base speed however, detailed observation can be readily made and by backing off the TRIG. LEVEL control more of the frame pulse can be viewed than is visible in the preset position.

When observing colour burst or chrominance signals, pulse and T bar displays, measurement will be accurate as the vertical bandwidth is flat within approx. 5% up to 5MHz for a 4 cm. display.

#### 5. CIRCUIT DESCRIPTION. (Drg. No. 1014 and 1019)

The circuit is divided into three (3) sections -

- (a) Vertical Amplifiers. (Drg. No. 1014)
- (b) Trigger Circuits and T.B. (Drg. No. 1019)
- (c) CRT EHT and Power Supplies. (Drg. No. 1019)

#### 5.1 VERTICAL AMPLIFIER. (Channel 'B'). (Drg. No. 1014)

Signals at the input socket are connected by S3 either directly or via C30 capacitor which removes the DC component to the attenuator switch S4A-D. This switch is in two sections, S4A and B attenuates the input in a stepped 1, 10, 100 and 1,000 sequence whilst S4C and D attenuate the signal in a repetitive 1, 2, 5 sequence. The effect of cascading these two sections is to attenuate signals in a 1, 2, 5, 10 sequence in twelve steps. Correct step response is maintained by making the series or shunt capacitors adjustable, whilst constant input capacitance is maintained by C32, 36, 39 and 41.

To protect the input FET stage Q11 from large overloads the input is taken through a high impedance in series with the input to the FET gate. Back to back diodes D7 and D8 taken to -3.5 and +3V rails prevent the input from exceeding these limits.

The amplifier is a balanced design from input to output with Q11 and Q12 FET input stage, Q13, Q14 amplifier stage and Q7 - Q10 cascode CRT driver stage.

Q11 and Q12 are FET's operated as a balance amplifier with a common source load, R57 and R58. Positioning voltage is applied to the drains via R59 and R60 from RV3 position control. A zener diode is also in the source load and serves to keep the gain of the stage constant when line voltage changes occur. The drain load for Q11 and Q12 consists of R61 and 62 shunted by the input impedance of the Q13 and 14.

## FIRST TIME OPERATION (Cont'd)

### 4.2 Cont'd.

waveform disappears and two flicker free traces appear. In general, the Alternate position is used when viewing frequencies above 100Hz and the Chopped mode below this. For single beam displays with Channel A off always push the switch in to the ALT position to eliminate chopping pulses on the trace.

### 4.3 Z MODULATION.

Feed an oscillator into the red rear panel socket marked 'Z'. With an input of 10V RMS or 30V p-p approx., the trace at normal brightness level will be intensity modulated. Z Modulation is not available in the chopped amplifier mode.

The following sections explain the operation of this Model when used to make specific measurements.

### 4.4 MEASUREMENT OF DC (DIRECT) VOLTAGES.

Set T. B. LEVEL CONTROL to AUTO. Switch the Vertical Amplifier AC-DC Switch to DC. For an initial test take a  $1\frac{1}{2}$ V dry cell and set the attenuator to 0.5V. Connect the negative end to the BLACK COMMON terminal, set the trace to the centre of the graticule, touch a lead from positive end of the battery to the input socket; the trace will move up to 3 cm., i.e.  $3 \times 0.5V \pm 1.5V$ . Now reverse the connections to the battery and note how the trace moves down 3 cm. This illustrates how an oscilloscope can display positive or negative voltages or both simultaneously, e.g. when viewing a sine input or square wave.

The DC input facility may be used to measure AC waveforms swinging about a DC Voltage, as at the collector of a transistor or the anode of a valve, to check for bias settings or anode bottoming, etc. Maximum DC input should not exceed X10 input attenuator setting if it is required to re-centre the trace to view a signal superimposed on it.

#### NOTE:

The  $1M\Omega$  input impedance of the oscilloscope must be taken into account when measuring high impedance points such as anode, grid or screen voltages of valves or the gate of FET's working with high value loads. To obtain a higher input use a P22 high impedance probe which increases the input to  $10M\Omega$  shunted by  $<14pf$ .

### 4.5 MEASUREMENT OF AN AC ALTERNATING VOLTAGE.

Set the Amplifier AC - DC switch to AC and the Attenuator to 20V (if the input voltage is unknown). Connect a lead from the BLACK input terminal to the ground (earth) side of the signal to be measured, then connect a lead from the input socket to the signal source. (Models 112B, 140A or 602 Oscillators are suitable for initial experiments in this test).

#### 4. FIRST TIME OPERATION (Cont'd).

##### 4.5 Cont'd

Increase the Vertical sensitivity by the VOLTS/CM switch until a display between 3 and say 8 cm. exists. Now adjust the Time Base Switch and Vernier to enable the waveform to be readily seen. To measure the amplitude of a displayed waveform, measure its overall height in cms. by the calibrated graticule, then multiply this by the attenuator setting and the result is in Volts p-p, e.g. if the display is 6 cm. high and the attenuator is set to 0.5V then the amplitude is  $6 \times 0.5 = 3V$  peak to peak, to convert to RMS voltage for sine waves, divide the 3V by 2.84, e.g.

$$\frac{3.00}{2.84} = 1.06V \text{ RMS}$$

The frequency of a waveform can be found by turning the Time Base Vernier to CAL (clockwise) then switch the TIME/CM switch to a range where the signal can be clearly seen, e.g. if a waveform is 5cm long and the switch is on 100uSec., then the duration of the waveform is  $5 \times 100\text{uSec.}$ . The frequency can be determined by dividing 1 Sec., i.e. 1,000,000uSec. by the duration of the waveform.

$$\frac{1,000,000}{500} = 2,000\text{Hz} = 2\text{kHz}$$

##### 4.6 CURRENT MEASUREMENTS AC OR DC.

Where it is possible to place a low value resistor in the earthy end of a circuit the current through this resistor can be found by viewing the voltage across it and converting it by ohms Law to current. By using a  $1\Omega$  resistor the attenuator calibrations read directly in mA or A in lieu of mV or W. When the oscilloscope is connected across it.

This will display AC or DC current and, unlike an ammeter, will show the actual current waveform. Practical applications are the charging currents in a filter capacitor of a power supply or the current through a rectifier via the centre tap of a transformer etc.

##### 4.7 MEASUREMENTS WITH AN EXTERNAL HORIZONTAL INPUT.

As the HORIZ. INPUT is directly coupled, the C.R.T. display can be used for X - Y plotting over an  $8 \times 10$  cm. area.

Switch to "T.B. OFF" and calibrate the Horizontal Amplifier by feeding in the CAL waveform and adjusting the HORIZ. MAG. until the display equals 1 cm. Set the Vertical Attenuator to 1V/cm. The oscilloscope has now identical X and Y sensitivities, of 1V p-p/cm. (Other sensitivities can be used with equal or unequal sensitivities as required).

Remove the CAL. waveform and centre the spot. Positive or negative voltages may be now applied to X and Y inputs and the result plotted on tracing paper placed over the C.R.T. or transferred to a ruled graph paper. AC signals will show phase displays or Lissajous figures. With the vertical input switched to DC less than  $2^\circ$  phase shift exists up to 10kHz and  $5^\circ$  at 20kHz between X and Y inputs. Dual trace displays can be obtained by pulling out the CHOP mode switch knob.



#### 4. FIRST TIME OPERATION. (Cont'd)

##### 4.1 Set controls as follows:-

Intensity	-	OFF (anticlockwise)
Focus	-	mid-position
<u>Amplifiers A &amp; B</u>		
Attenuator	-	.2V/cm.
Vert. Position	-	mid-position
Input Selectors	-	AC
Alt-Chop Switch	-	Chop (pulled out).
<u>Time Base.</u>		
Time Base Range	-	10mSec/cm.
Vernier	-	Clockwise (Cal).
Trigger Level	-	AUTO (anticlockwise)
± Select	-	+
NORM - T.V.	-	NORM
INT-EXT.	-	INT
HOR. MAG	-	Anti-Clockwise X1
HOR. POSITION	-	Mid-position

- 4.2 Connect instrument to power mains, (check transformer tapping as in 4.1) then switch instrument on. After about 10 seconds when traces appear, adjust beam for suitable intensity and sharp focus. Now position traces centrally across screen. Connect a lead from the CAL socket to the 'B Channel' input socket. A 50Hz square wave will be displayed with the top and bottom faces of the waveform sloping. Switch the input selector to DC. The square wave will be displayed positive going to the base line. Recentre with position control. Adjust Time Base range switch and vernier to check characteristics with two waveforms displayed, change over ± trigger selector switch. Turn the Level Selector control clockwise. This switches off AUTO, the trace will disappear then re-appear as control is rotated and the point at which the trace is initiated will move up or down the edge of the waveform as selected by the ± selector. It will disappear when almost fully clockwise.

Return the control to AUTO and adjust the TIME/CM switch to give five waveforms across the CRT, then turn the HORIZ. MAG control clockwise until one waveform is 10 cm. long; this illustrates the trace expansion facility. If the horizontal position is turned the trace can be tracked along to view any part of it from one end to the other.

To check the X INPUT, turn the T.B. Vernier to T.B. OFF. Connect a lead from the CAL socket to the X INPUT socket, a horizontal line will appear whose length can be varied by the HORIZ. MAG control from 1 cm. down to less than .2 cm. The Horizontal position of the trace can be set by the HORIZ. POSITION control.

Instead of the CAL waveform connect an audio oscillator (e.g. Models 140A, 112B or 602) to Channel 'B' input. Set input frequency to 1kHz - increase Time Base speed and note how in the Chopped mode, the individual chopped segments of the waveform appear. Push the switch in to the Alternate position. The chopping

## 5. CIRCUIT DESCRIPTION. (Cont'd).

### 5.1 VERTICAL AMPLIFIER (Channel 'B') (Cont'd).

Q13 and 14 is a series compensated stage, RV26 and C48 compensate for H.F. response and RV4 preset gain control adjusts calibration. Negligible change in response occurs with adjustment of RV4.

The trigger amplifier is a high gain wideband integrated circuit driven from the common source connection of Q11 and 12 when S14 is switched to 'B' & Q1 & 2 when switched to 'A'. Signals to the in-phase input pass through R15, signals to the anti-phase input are filtered out by R18 and C22. This applies a balanced DC input to the I.C. Feedback to control the I.C. gain is taken from the output via R14 to the -ve input. The AC gain is approx. 470 - the ratio of R14 to R15 but the DC gain which controls the stability of the amplifier when line or temperature changes occur is only 55 - the ratio of R14 to R16 and R18 in series. H.F. Stability is maintained by C21. The H.F. response is attenuated by C18 and R13 when the chopped mode is employed to prevent switching spikes from feeding through to the trigger circuit.

Positive (+ve) supply to the I.C. is part of output amplifier stage emitter current bypassed by C25. The negative supply is via R17 from the -54V rail and filtered by C20.

Channel A is identical to Channel B, the position control having a switch incorporated (S6) which disables the beam switching circuit when only single beam operation is required.

To enable both inputs to be displayed on a single beam CRT the A & B amplifiers are alternatively connected to the common amplifier stage on a 50-50 time sharing basis.

At low time base speeds the time sharing is operated in CHOPPED Mode when the beam switch free-runs at 150kHz. At higher time base speeds when persistence of vision eliminates the visible effect of time sharing the beams switch changes over during the return period of the time base sweep providing an ALTERNATE display.

The methods of coupling the amplifiers to Q5 and 6 is via diodes. Assuming Channel A is being displayed and B is cut off. The voltage at the junction of D3 and D4 is pulled down to +11 by the bi-stable switch Q15 and 16, well below the +15 at the base of Q5 and 6 so D3 and 4 are cut off. Q3 and Q4 are always biased in a conducting condition so the only source of collector current is via the shunt feedback resistors R28 and 29 across Q5 and 6. This puts the coupling diodes D5 and 6 into conduction and completes the amplifier chain. To cut off Channel B, D9 and D10 are pulled into conduction by the action of the bi-stable switch Q15 and 16 which raises the voltage at the junction of D9 and D10 to approximately +18. This turns off the coupling diodes D11 and 12 preventing any signal transfer to Q5 and Q6. Collector current for Q13 and 14 is now obtained from the bi-stable collector load R66 via D9 and 10. The conduction of D9 and 10 also shunts the collectors Q13 and 14 so minimising feed through of Channel B signals.

## 5. CIRCUIT DESCRIPTION. (Cont'd.)

### 5.3 TRIGGER CIRCUIT. (Cont'd.)

In the AUTO position S10A is open allowing R105 and 107 to set trigger level. When S10A closes in Trigger Level condition additional positive or negative voltage from RV9 via R106 overrides the preset condition and provides a selection level of the trigger waveform.

The schmitt trigger stage Q21 and 22 produces a sharp rectangular output waveform from any shape input.

The action is as follows, with Q21 conducting, its collector will bottom and Q22 will be cut off by the voltage divider action across R110, R111 and RV10. A negative going input signal from the phase splitter will cut off Q21, its collector will rise pulling Q22 base positive, so turning Q22 on, producing a negative pulse at its collector. As the emitters are coupled together, the current through Q22 will now hold Q21 off until its base is driven positive above the common emitter potential and the switching action is reversed. The sharp negative fall across R113 is differentiated by C76 then applied to Q24 base in the time base circuit. Trigger sensitivity is set by RV10.

### 5.4 TIME BASE CIRCUIT. (Drg. No. 1019)

The Time Base sawtooth generator consists of Q24 and 25 bi-stable trigger, Q27 source follower Q28 Miller sawtooth generator and Q29 emitter follower with associated clamping diodes D15, 16, 17, 18 and 19. The function is as follows:

Assuming Q24 is conducting, Q25 will be cut off, its collector will rise and D18 will conduct, pulling the gate of Q27 and hence the base of Q28 positive. The collector of Q28 will fall to approximately +5V together with Q29 base. At this point diode D19 connected into the emitter load of Q29 passes below zero and starts to conduct pulling D18 to a lower conduction level producing a static stable condition.

In this direct coupled quiescent state, the trace will be ready for a trigger input pulse. A negative pulse on Q24 base will cause the collector to rise taking Q25 base positive. This causes current to flow through Q25 into the emitter resistor R127, biasing Q24 off further and a rapid cumulative action occurs in which Q24 cuts off and Q25 saturates. D18 becomes reverse biased, Q27 is left with its gate at -1.5V approximately and connected through the timing resistor R99 to R104 to a negative potential on RV11 which will pull Q27 and thereby Q28 towards cut-off.

Q27 FET source follower presents a high impedance to the charging circuit enabling high value charging resistors to be utilised with small high stability timing capacitors. Q29 emitter follower provides a low output impedance to charge the capacitors and drive the output and gating circuits. As Q27 gate and Q28 base fall, Q28 collector rises and via Q29, R135 and C83, a charge is applied to the selected timing capacitor on S11D. The result of this negative feedback is to linearise the charging rate to the timing capacitor by keeping the voltage across the charging resistor constant and thereby the charging current. A positive going sawtooth waveform is generated at the collector of Q28 and base of Q29 where it appears at low impedance at its emitter.

## 5. CIRCUIT DESCRIPTION. (Cont'd)

### 5.1 VERTICAL AMPLIFIER. (Channel 'B' (cont'd)).

When the bi-stable switches changes over the above action is reversed Channel A is cut off and Channel B conducts through D11 and 12.

Q5 and Q6 shunt feed back stage has a low input and output impedance. As a result of the low input impedance, capacitive loading of the two amplifiers and diode gates etc., has little effect on high frequency fall off. Similarly the low output impedance enables the stage to drive Q7 and Q8 cascode drivers directly. The C.R.T. deflection plate drivers are emitter coupled to Q7 and Q8 to minimise capacitive feedback and so maintain a wide bandwidth. H.F. compensation for the stage is provided by RV5 C27 and C26.

### 5.2 BEAM SWITCH CIRCUIT. (Drg. No. 1014)

Q15 and Q16 are a bi-stable switch, combining both collector and emitter coupling. In the CHOP Mode separate emitter resistors R68 and R75 are connected to ground via S5B and Q17 which is always conducting by the forward bias through R72. C52 between the emitters together with R67, R73 and C51 on one side and R69, C50 and R77 on the other cause the stage to oscillate at a frequency <100kHz. The resulting push-pull square waves at the collectors gate Channel A & B off and on. To eliminate the display when switching occurs a positive pulse is taken from C53 and C54 junction to Q18. The pulses turn on Q18, pull the collector down producing a sharp negative going pulse which is applied to the C.R.T. blanking electrode.

When S5B is switched to ALT Q15 and Q16 emitters are coupled together by D13 and D14 and then taken by R70 to the collector of Q17. This sets the circuit as a bi-stable switch. When a negative going pulse is received from the time base, Q17 cuts off, the emitters of Q15 and Q16 rise. If we assume Q15 was conducting it will cut off, its collector rises and via C50 pulls Q16 base more positive than Q15 base. Therefore, when the pulse to Q17 base is removed, Q17 conducts pulling Q16 into conduction before Q15, thereby changing the state of the bi-stable.

### 5.3 TRIGGER CIRCUIT. (Drg. No. 1019)

S7 selects the internal or external source of trigger which is then fed via C61 to Q19 phase splitter. S8A selects + or - slope before applying the signal via S9A to Q20 or direct to the Schmitt trigger. In the T.V. position Q20 which is permanently conducting, D.C. restores the signal by base current conduction. As the signal applied to Q20 is negative going only the positive going sync pulses will be amplified, the video signal driving the stage into cut off. Frame pulses are integrated by R98 and C65 producing a composite sync signal of low level line pulses and a 15V frame pulse.

In this way AUTO trigger operates on the low level line signal but only the high amplitude frame pulse operates in trigger level position.

S9B selects the normal or T.V. sync signal which passes via C74 to Q21.

## 5. CIRCUIT DESCRIPTION. (Cont'd).

### 5.4 TIME BASE. (Cont'd).

The sawtooth continues to rise until the potential at the junction on RV13 reaches approx.  $-4V$ . D17 conducts and charges C78 and C68 and C69 as selected by S11B. It also takes the base of Q24 positive to its emitter potential and continues positively until Q24 conducts causing its collector to fall cutting off Q25 and at the same time transferring the emitter current from Q25 to Q24. D18 conducts pulling the gate of Q27 positively, Q28 collector falls, the timing capacitor is rapidly discharged until Q29 emitter falls sufficiently to cause D19 to conduct to pull D18 back to a quiescent condition and stabilise the circuit ready for the next trigger pulse. This will initiate the next trace once the hold-off capacitors C79 and 66 - 67 as selected by S11A have discharged sufficiently through R117 and the base current of Q24 to allow a trigger pulse to cut Q24 off.

AUTO Time base operation is obtained by allowing the clamping network for Q24 base to run down at a controlled rate until the time base automatically turns itself on if no trigger pulse arrives during the run down. Q26 clamp discharges C79 and 66 - 67 as selected by S11A and holds the top of R117 at  $-0.2V$  during the normal sweep period as its base is held negative to its emitter by current through R129 and Q25. During the return trace when Q25 rises it cuts off Q26 thus permitting C79 and 66 - 67 as selected, to charge negatively through R117, 118 and 119. When the junction of R117 and 8 falls below the emitter potential of Q24 it ceases to conduct, its collector rises and the cumulative switching action previously described occurs, with the resultant sawtooth sweep generation. During this period Q26 is pulled into conduction to discharge the AUTO. capacitors in readiness for the next run down.

The progressive reduction in capacitor value as the sweep speed rises results in a bright reference base line at all time base speeds and provides more reliable triggering at very high frequencies.

C.R.T. Blanking by the Time Base Circuit is accomplished by directly coupling the C.R.T. Blanking Electrode to Q23 collector which is driven between the clamping limits of  $+0V$  and  $+54V$ . Q23 is driven by Q24 via R116 base resistor and conducts during the forward trace, but is biased off during the return trace.

The square wave at Q24 collector is differentiated and limited by C80 and R123 before it is applied to Q17 base to switch the bi-stable beam switch during the return trace period.

### 5.5 HORIZONTAL AMPLIFIER. (Drg. No. 1019)

Three transistors Q30, 31 and 32 amplify the Time Base and Horizontal Input to provide the high voltage horizontal deflection voltages.

## 5. CIRCUIT DESCRIPTION. (Cont'd).

### 5.5 HORIZONTAL AMPLIFIER. (Cont'd).

Q30 is a shunt feedback stage, RV14B (HORIZ. MAG.) varies the feedback and hence the stage gain. RV15 presets the minimum gain ( $\times 1$  Mag.).

The time base sawtooth, the horizontal X Input and the Horizontal position are all applied to Q30 base via mixing resistors R138, R139 and R140.

The low impedance output from Q30 feeds Q31 and Q32 long tail pair which in turn drive the C.R.T. deflection plates directly. Horizontal centreing is preset by RV16.

### 5.6 C.R.T. AND SUPPLIES. (Drg. No. 1019)

Type D13/27 C.R.T. requires approximately equal + and - E.H.T. supplies for correct operation. The negative supply is a voltage doubler consisting of D201 and 202 with C201 to 204 capacitors. A second stage of filtering R205 and C205 reduces ripple to a low level. C.R.T. potentials are taken from a divider across the -1400 supply consisting of R160, RV19 Focus Control, R161, RV24 Intensity Control and RV206 Intensity range preset.

The C.R.T. grid is returned to the -1400V rail via R208 grid resistor. RV24 INTENSITY control varies the impedance of the divider between grid and cathode and so varies the potential between them thus changing the beam current and trace brightness.

Z Modulation is coupled through C207 to the C.R.T. grid. All other electrode voltages are preset RV18 Astigmatism control and RV17 Geometry controls are located between low voltage rails.

The PDA supply, like the negative E.H.T. supply, is a voltage doubler rectified by D203 and D204 with C210 and C209 coupling capacitor and filter. D204 is returned to the +53 rail to add this potential to the PDA voltage.

### 5.7 LOW VOLTAGE POWER SUPPLIES. (Drg. No. 1019)

Two secondary windings provide the main DC supplies. + and -64V is obtained from the 51V winding by half wave rectifying by D22 and 23 followed by three stages of filtering for the various circuits. +200V is obtained by doubling the 82V winding by D20 and D21. Separate filters are used for the vertical and horizontal amplifiers, R152 and 153 and C89 for the vertical and R155, C88 for horizontal.

### 5.8 CALIBRATOR. (Drg. No. 1014)

The 51V AC supply is fed to Q201 emitter. Q201 clamps the signal going positively by its zener diode action and negatively by its forward diode action. The resultant square wave is divided down by R210 and RV201 to supply 1V p-p output at the front panel socket.

TOP VIEW  
SHOWING  
LOCATION  
OF PRESET  
CONTROLS  
ETC.

RV 201  
CAL  
WAVEFORM  
PRESET.

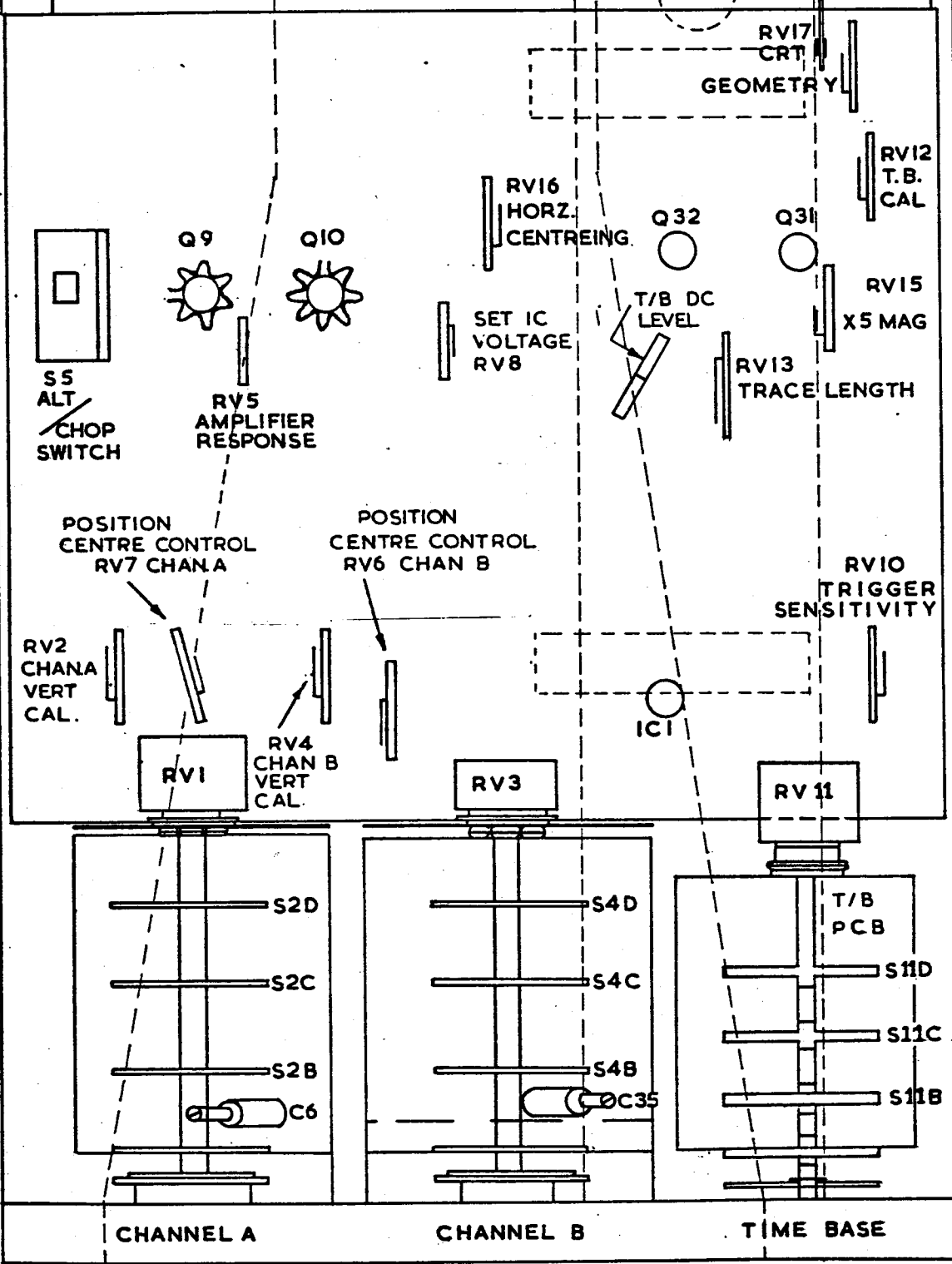

S5  
ALT  
CHOP  
SWITCH

Q9

Q10

RV5  
AMPLIFIER  
RESPONSE

RV16  
HORZ.  
CENTREING.

Q32

RV17  
CRT

GEOMETRY

RV12  
T.B.  
CAL

SET IC  
VOLTAGE  
RV8

T/B DC  
LEVEL

Q31

RV15  
X5 MAG

RV13  
TRACE LENGTH

POSITION  
CENTRE CONTROL  
RV7 CHAN A

POSITION  
CENTRE CONTROL  
RV6 CHAN B

RV2  
CHAN A  
VERT  
CAL.

RV4  
CHAN B  
VERT  
CAL.

RV10  
TRIGGER  
SENSITIVITY

ICI

RV1

RV4  
CHAN B  
VERT  
CAL.

RV3

RV 11

S2D

S2C

S2B

C6

S4D

S4C

S4B

C35

T/B  
PCB

S11D

S11C

S11B

539

CHANNEL A

CHANNEL B

TIME BASE

539  
111

## 6. ADJUSTMENTS AND MAINTENANCE.

A number of preset controls are contained in this instrument which may require periodical adjustments to maintain it in full calibration.

Before removing the top cover, disconnect the instrument from the mains. Remove the two screws holding the handle and withdraw the cover. The bottom cover may be removed by unscrewing the four feet.

The aid fault finding the voltages present at various points are shown on the circuit.

### 6.1 ALIGNMENT PROCEDURE.

Before attempting re-alignment of any section of this Oscilloscope, check the instruments general operating characteristics and correct any apparent faults. Also check DC rails as variation in supply voltages caused by a fault may result in miscalibration.

### 6.2 General check of controls -

(a)	Intensity	Linear control over intensity range.
(b)	Focus	Approx. centre with adjustment either side.
(c)	Horiz. Mag.	Trace should expand equally either side of centre.
(d)	Vert. Positions	Traces should move completely off screen above and below centre.
(e)	Trigger Level	With Atten. at 0.2V and CAL signal fed into AC Input check AUTO and Level Select operation.
(f)	+ - Switch	Set up as for (e) Trigger point should change over as indicated by switch.
(g)	X Input & Mag.	Feed CAL signal into Horiz. Input socket with T.B. VERNIER turned to T.B. OFF HORIZ. MAG should vary display from 2mm to over 1cm.

### 6.3 C.R.T. TRACE ALIGNMENT.

Feed a 1,000Hz square wave signal into the Channel B and adjust wave form to fill the screen. T.B. to 1mSec. VERNIER CAL.

RV18 Rear Panel astigmatism control is adjusted in conjunction with the FOCUS control to obtain the best resolution over the entire screen area.

RV17 at rear of main board adjusts the pattern geometry. It should be set to display vertical and horizontal lines with minimum of pin cushion or barrel distortion. RV18 may need slight re-adjustment after RV17 has been set as some interaction occurs.



RV18  
ASTIGMATISM

T1

BOTTOM VIEW SHOWING  
LOCATION OF PRESET  
CONTROLS ETC.

C27

AMPLIFIER  
RESPONSE

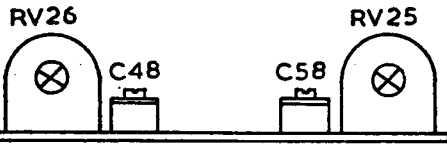

C45

RV21  
RV22

RV23

SI4

C16

C70

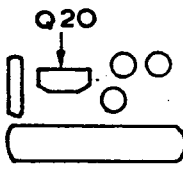

C15

C12

C15

C12

C39

C11

C10

C11

C33

C4

C32

C36

C3

C7

T. BASE

CHAN  
B

CHANNEL  
A.

539

7. REPLACEMENT PARTS

Spares are normally available from the manufacturer. When ordering, it is necessary to indicate the serial number of the instrument. If exact replacements are not to hand, locally available alternatives may be used, provided they possess a specification not less than, or physical size not greater than, the original components.

As the policy of the supplier is one of continuing research and development, the Company reserves the right to supply the latest equipment and make amendments to circuits and parts without notice.

8. WARRANTY

The equipment is guaranteed for a period of twelve (12) months from the date of purchase against faulty materials and workmanship.

Please refer to Guarantee Registration Card No. 10327 which accompanied instrument for full details of conditions of warranty.

\* \* \* \* \*

6. ALIGNMENT PROCEDURE (Cont'd.)

6.3 C.R.T. TRACE ALIGNMENT (Cont'd.)

EQUIPMENT REQUIRED FOR COMPLETE CALIBRATION -

- 20,000Ω/V meter or DVM. Pulse generator <10nS tr.
- Voltage calibrator 0.5% accuracy 20mV to 100V p-p.
- Sine wave generator 1Hz to 1MHz.
- Constant amplitude generator 50KHz to 50MHz.

6.4 VERTICAL ALIGNMENT

- (a) Set all presets to mid position and adjust RV8 for 5.8V between pins 3 & 4 for IC1.
- (b) Set both attenuators to 0.01V, feed a 50mV p-p square wave to both inputs and adjust RV2 and RV4 for a 5 cm. display on Channels A & B respectively. Check other positions.
- (c) Set time base to 0.1 sec/cm, and with no input signal adjust RV21 for <±1cm trace shift for a ±10% mains voltage charge and <2mm trace deviation at centre screen. Repeat for Channel B (RV23).
- (d) Set vertical shift to mid rotation and adjust RV7 for trace centering. Check that shift control moves trace equally up and down - if not reset RV7. Repeat for Channel B (RV6).
- (e) Adjust RV22 for zero volts between A and B on S14.
- (f) Adjust RV26 & C48 for best square wave response on Channel B. Input 500KHz and 3 cm. display.
- (g) Adjust RV25 & C58 on Channel A for similar square wave response to Channel B.

6.5 ATTENUATOR ALIGNMENT

Initially set attenuators to .02V and set C42 and C12 to mid positions and adjust C45 (16) for best square wave response. Figures in brackets are Channel A.

<u>Attenuator Setting</u>	<u>Input Voltage</u>	<u>Adjust for Square Wave</u>	<u>Adjust for Input Capacitance</u>
0.5V	200mV	C40 (15)	-
0.1V	500mV	C33 (4)	C32 (3)
0.2	1V	C41 (11)	-
0.5	2V	C39 (10)	-
1	5V	C35 (6)	C36 (7)

Attenuators will be automatically aligned at all other positions.

REPLACEABLE PARTS

1. This section contains information for ordering replacement parts, it provides the following details : -
  - (a) Description of part (see list of abbreviations).
  - (b) Typical manufacturer or supplier of the part (see list of abbreviations).
  - (c) Manufacturer's Part Number, and
  - (d) Defence Stock Number, where applicable.
  
2. Ordering - Please quote Model Type No., e.g. bwd 511, Serial No. Circuit Reference No. and component details as listed in parts list.

COMPONENT DESIGNATORS

A	Assembly	H	Heater	RV	Resistor Variable
B	Lamp	J	Jack (socket)	S	Switch
C	Capacitor	L	Inductor	T	Transformer
D	Diode	M	Meter	TH	Thermistor
DL	Delay Line	P	Plug	V	Valve
E	Misc. Elect. Part	Q	Transistor	VDR	Voltage Dependent Resistor
F	Fuse	R	Resistor		

ABBREVIATIONS

Amp	Ampere	L	Inductor
C	Capacitor	lin	Linear
cc	Cracked Carbon	Log	Logarithmic Taper
c	Carbon	m	Milli = $10^{-3}$
cd	Deposited Carbon	MHz	Mega Hertz = $10^6$ Hz
comp	Composition	MF	Metal Film
CDS	Ceramic Disc Capacitor	ma	Milli Ampere
cer	ceramic	MΩ	Meg Ohm = $10^6$ Ω
Com	Common	mfr	Manufacturer
DPST	Double Pole Single Throw	MO	Metal Oxide
DPDT	Double Pole Double Throw	MHT	Polyester/Paper Capacitor
elec	Electrolytic	MPC	Metalised Polyester Capacitor
F	Farad	Ne	Neon
f	Fuse	NPO	Zero temperature co-efficient
FET	Field Effect Transistor	nsr	Not separately replaceable
Ge	Germanium	NC	Normally Closed
H	Henry(ies)	NO	Normally Open
H.S.	High Stability	ns	Nano second
HTC	High Temp Coating	obd	Order by Description
ins	Insulated	OD	Outside Diameter
kHz	Kilo Hertz = $10^3$ Hz	p	Peak
KΩ	Kilo Ohm = $10^3$ Ω	pf	pico farad = $10^{-12}$ F

## 6. ALIGNMENT PROCEDURE. (Cont'd)

### 6.6 CALIBRATOR ADJUSTMENT.

When amplifier is correctly calibrated against an external standard set its attenuator to .2V, Vernier to CAL and feed in the 1V calibrate waveform (input switched to DC). Adjust RV201 on the bottom of vertical board for 5 cm. deflection.

### 6.7 TIME BASE ALIGNMENT.

- (a) Set T.B. Range to 1mSec. Vernier to CAL. Check trace length is 10.5 cm. approx. Set with RV13 if necessary.
- (b) Feed into amplifier 1mSec. pulses. Adjust No. 1. pulse to correspond to 1st graticule line. Adjust RV11 (rear main board) for 1 pulse/cm. Expand trace to X5. Adjust RV15 (for 1 pulse/5 cm.) Return to X1 and reset RV11 if necessary for 1 pulse/cm.
- (c) Now check lower time base speeds down to .5 seconds/cm. and at higher speeds up to 50uSec/cm. If it is noticed that most ranges appear slightly slower or faster than the nominal, RV11 may be reset to obtain the best overall calibration accuracy.
- (d) Turn the range switch to 10uSec/cm. Feed in a 10uSec pulse. Calibration may now be adjusted by C71 on lower side of T.B. Switch. Check calibration from 20uSec to 1uSec and if necessary reset C71 for best calibration over range.

### 6.8 TRIGGERING.

- (a) Set Time Base to 10uSec/cm. AUTO Trig, + and NORM. selection. Couple a 50kHz input to a vertical amplifier. Progressively reduce input level to below 1 cm. When trace fails to lock adjust RV10 for lock and continue reducing input - until RV10 fails to lock trace.
- (b) Change from + to - slope. Reset RV10 if necessary to optimise setting.
- (c) Increase input to 1cm., increase frequency up to 10MHz maintaining 1cm. signal level trace should remain locked on +ve at highest time base speeds, and up to approx. 8 MHz on -ve selection.
- (d) At low frequencies trace will lock at 5Hz with 1 cm. deflection. Increase signal to fill screen at 1kHz, check operation of TRIG LEVEL control over full range both + and - slope.
- (e) Adjustment of RV22. Feed two different frequencies into channels A and B, adjust RV22 so that the time base locks instantly when changing trigger source from channel A to channel B.

### 6.9 HORIZONTAL AMPLIFIER

- (a) Turn T.B. Vernier to T.B. OFF; increase MAG to x5, centre spot. Feed in 50kHz signal. Adjust input for 6 cm. horizontal display. Increase frequency to 500kHz. Amplitude should not drop below 4.2 cm.
- (b) Instrument is now calibrated.

PARTS LIST - MODEL bwd 539A

ITEM NO.	DESCRIPTION				Mfr. or Supply	PART NO.
R48	9.1KΩ	1%	MO	H.S	Electro	TR5
R49	1KΩ	1%	MO	H.S	Electro	TR5
R50	33Ω	5%	$\frac{1}{2}$ W CC		P1	
R51	800KΩ	1%	MO		Electro	TR5
R52	500KΩ	1%	MO		Electro	TR5
R53	1MΩ	1%	MO		Electro	TR5
R54	250KΩ	1%	MO		Electro	TR5
R55	270KΩ	5%	$\frac{1}{2}$ W CC		P1	
R56	1MΩ	1%	MO		Electro	TR5
R57	1KΩ	5%	$\frac{1}{2}$ W CC		P1	
R58	2.2K	5%	$\frac{1}{2}$ W CC		P1	
R59	100KΩ	5%	$\frac{1}{2}$ W CC		P1	
R60	100KΩ	5%	$\frac{1}{2}$ W CC		P1	
R61	560Ω	5%	$\frac{1}{2}$ W CC		P1	
R62	560Ω	5%	$\frac{1}{2}$ W CC		P1	
R63	390Ω	5%	$\frac{1}{2}$ W CC		P1	
R64	12KΩ	5%	$\frac{1}{2}$ W CC		P1	
R65	12KΩ	5%	$\frac{1}{2}$ W CC		P1	
R66	2.2K	5%	$\frac{1}{2}$ W CC		P1	
R67	15KΩ	5%	$\frac{1}{2}$ W CC		P1	
R68	2.7KΩ	5%	$\frac{1}{2}$ W CC		P1	
R69	18KΩ	5%	$\frac{1}{2}$ W CC		P1	
R70	1.2KΩ	5%	$\frac{1}{2}$ W CC		P1	
R71	1.2K	5%	$\frac{1}{2}$ W CC		P1	
R72	220KΩ	5%	$\frac{1}{2}$ W CC		P1	
R73	18KΩ	5%	$\frac{1}{2}$ W CC		P1	
R74	2.2KΩ	5%	$\frac{1}{2}$ W CC		P1	
R75	2.7KΩ	5%	$\frac{1}{2}$ W CC		P1	
R76	470Ω	5%	$\frac{1}{2}$ W CC		P1	
R77	15KΩ	5%	$\frac{1}{2}$ W CC		P1	
R78	3.3KΩ	5%	$\frac{1}{2}$ W CC		P1	
R79	33KΩ	5%	$\frac{1}{2}$ W CC		P1	
R80	33Ω	5%	$\frac{1}{2}$ W CC		P1	
R90	220KΩ	5%	$\frac{1}{2}$ W CC		P1	
R91	330KΩ	5%	$\frac{1}{2}$ W CC		P1	
R92	180KΩ	5%	$\frac{1}{2}$ W CC		P1	
R93	10KΩ	5%	$\frac{1}{2}$ W CC		P1	
R94	4.7KΩ	5%	$\frac{1}{2}$ W CC		P1	
R95	10KΩ	5%	$\frac{1}{2}$ W CC		P1	
R96	8.2MΩ	5%	$\frac{1}{2}$ W CC		P1	
R97	100KΩ	5%	$\frac{1}{2}$ W CC		P1	
R98	6.8KΩ	5%	$\frac{1}{2}$ W CC		P1	

PARTS LIST - MODEL bwd 539A

ITEM NO.	DESCRIPTION				Mfr. or Supply	PART NO.
R1	.900KΩ	1%	MO	-H.S	Electro	TR5
R2	111KΩ	1%	MO	H.S	Electro	TR5
R3	990KΩ	1%	MO	H.S	Electro	TR5
R4	9.1KΩ	1%	MO	H.S	Electro	TR5
R5	1KΩ	1%	MO	H.S	Electro	TR5
R6	33Ω	5% ½W	CC		P1	
R7	800KΩ	1%	MO	H.S	Electro	TR5
R8	500KΩ	1%	MO	H.S	Electro	TR5
R9	1MΩ	1%	MO	H.S	Electro	TR5
R10	250KΩ	1%	MO	H.S	Electro	TR5
R11	270KΩ	5% ½W	CC		P1	
R12	1MΩ	1%	MO	H.S	Electro	TR5
R13	33Ω	10% ½W	C		MOR	
R14	470K	5% ½W	CC		P1	
R15	220Ω	5% ½W	CC		P1	
R16	1KΩ	5% ½W	CC		P1	
R17	8.2K	5% ½W	CC		P1	
R18	10KΩ	5% ½W	CC		P1	
R19	470Ω	5% ½W	CC		P1	
R20	100KΩ	5% ½W	CC		P1	
R21	100KΩ	5% ½W	CC		P1	
R22	560Ω	5% ½W	CC		P1	
R23	560Ω	5% ½W	CC		P1	
R24	390Ω	5% ½W	CC		P1	
R25	12KΩ	5% ½W	CC		P1	
R26	12KΩ	5% ½W	CC		P1	
R27	2.7KΩ	5% ½W	CC		P1	
R28	5.6KΩ	5% ½W	CC		P1	
R29	5.6KΩ	5% ½W	CC		P1	
R30	1.5KΩ	5% ½W	CC		P1	
R31	1.5KΩ	5% ½W	CC		P1	
R32	220Ω	5% ½W	CC		P1	
R33	680Ω	5% ½W	CC		P1	
R34	100Ω	5% ½W	CC		P1	
R35	100Ω	5% ½W	CC		P1	
R36	330Ω	5% ½W	CC		P1	
R37	680Ω	5% ½W	CC		P1	
R38	1KΩ	5% ½W	CC		P1	
R39	680Ω	5% ½W	CC		P1	
R40	680Ω	5% ½W	CC		P1	
R41	330Ω	5% ½W	CC		P1	
R42	5.6KΩ	5% 1W	CC		P1	
R43	5.6KΩ	5% 1W	CC		P1	
R44	900KΩ	1%	MO	H.S	Electro	TR5
R45	111KΩ	1%	MO	H.S	Electro	TR5
R46	990KΩ	1%	MO	H.S	Electro	TR5

PARTS LIST - MODEL bwd 539A

ITEM NO.	DESCRIPTION				Mfr or Supply	PART NO.
R99	100KΩ	1%		MO	Electro	TR5
R100	100KΩ	1%		MO	Electro	TR5
R101	500KΩ	1%		MO	Electro	TR5
R102	1MΩ	1%		MO	Electro	TR5
R103	1MΩ	1%		MO	Electro	TR5
R104	5MΩ	1%		MO	Electro	TR5
R105	22KΩ	5%	1/2W	CC	P1	
R106	100KΩ	5%	1/2W	CC	P1	
R107	180KΩ	5%	1/2W	CC	P1	
R108	33KΩ	5%	1/2W	CC	P1	
R109	1KΩ	5%	1/2W	CC	P1	
R110	10KΩ	5%	1/2W	CC	P1	
R111	27KΩ	5%	1/2W	CC	P1	
R112	6.8KΩ	5%	1/2W	CC	P1	
R113	2.2K	5%	1/2W	CC	P1	
R114	47KΩ	5%	1/2W	CC	P1	
R115	47KΩ	5%	1/2W	CC	P1	
R116	3.3KΩ	5%	1/2W	CC	P1	
R117	39KΩ	5%	1/2W	CC	P1	
R118	2.2KΩ	5%	1/2W	CC	P1	
R119	180K	5%	1/2W	CC	P1	
R120	6.8KΩ	5%	1/2W	CC	P1	
R121	47KΩ	5%	1/2W	CC	P1	
R122	33KΩ	5%	1/2W	CC	P1	
R123	3.3K	5%	1/2W	CC	P1	
R124	150Ω	5%	1/2W	CC	P1	
R125	15KΩ	5%	1/2W	CC	P1	
R126	120KΩ	5%	1/2W	CC	P1	
R127	22KΩ	5%	1/2W	CC	P1	
R128	39KΩ	5%	1/2W	CC	P1	
R129	2.2KΩ	5%	1/2W	CC	P1	
R130	2.2KΩ	5%	1/2W	CC	P1	
R131	22KΩ	5%	1/2W	CC	P1	
R132	17K	5%	1/2W	CC	P1	
R133	150Ω	5%	1/2W	CC	P1	
R134	100KΩ	5%	1/2W	CC	P1	
R135	2.2KΩ	5%	1/2W	CC	P1	
R136	8.2K	5%	1/2W	CC	P1	
R137	15KΩ	5%	1/2W	CC	P1	
R138	18K	5%	1/2W	CC	P1	
R139	56KΩ	5%	1/2W	CC	P1	
R140	68KΩ	5%	1/2W	CC	P1	
R141	68KΩ	5%	1/2W	CC	P1	
R142	15KΩ	5%	1/2W	CC	P1	
R143	1.2KΩ	5%	1/2W	CC	P1	
R144	47KΩ	5%	1/2W	CC	P1	



## COMPONENT ABBREVIATIONS (cont.)

PL	Plug	SPDT	Single Pole Double Throw
PS	Socket	SPST	Single Pole Single Throw
Preset	Internal Preset	S.Shaft	Slotted Shaft
PYE	Polyester	Si	Silicon
pot	Potentiometer	Ta	Tantalum
prec	Precision	tol	Tolerance
PC	Printed circuit	trim	trimmer
PIV	Peak Inverse Voltage	V	Volt(s)
PYS	Polystyrene	var	variable
p-p	Peak to Peak	vdcw	Volts Direct Current Working
P.Shaft	Plain Shaft	w	Watt(s)
Q	Transistor	ww	Wire Wound
R	Resistor	Z	Zener
rot	rotary	*	Factory Selected value, nominal value may be shown
R log	Reverse Logarithmic Taper	**	Special component, no part no. assigned
rms	Root Mean Squared		

## MANUFACTURERS ABBREVIATIONS

AB	A.B. Electronics	J	Jabel
AEE	AEE Capacitors	McH	McKenzie & Holland(Westinghouse)
AN	Anodeon	MAS	Master Instrument Co. Pty. Ltd.
AST	Astronic Imports	MOR	Morganite (Aust.) Pty. Ltd.
AWA	Amalgamated Wireless of Aust.	MSP	Manufacturers Special Products (AWA)
ACM	Acme Engineering Pty. Ltd.	McM	McMurdo (Aust.) Pty. Ltd.
AMP	Aircraft Marine Products(Aust.) P/L	MOT	Motorola
AR	A. & R. Transformers	NU	Nu Vu Pty. Ltd.
AUS	Australux Fuses	NAU	A. G. Naunton Pty. Ltd.
AWV	Amalgamated Wireless Valve Co.	NS	National Semiconductor
ACA	Amplifier Co. of Aust.	PA	Painton
ARR	Arrow	PAL	Paton Elect. Pty. Ltd.
BWD	B.W.D. Electronics Pty. Ltd.	PI	Piher Resistors (Sonar Electronics)
BL	Belling & Lee Pty. Ltd.	PH	Philips Electrical Industries Pty. Ltd.
BR	Brentware (Vic.) Pty. Ltd.	PL	Plessey Pacific
BU	Bulgin	PRO	Procel
CF	Carr Fastener	PV	Peaston Vic.
CAN	Cannon Electrics Pty. Ltd.	RC	Radio Corporation (Electronic Inds.)
CIN	Cinch	RCA	Radio Corporation of America
DAR	Darstan	RHC	R. H. Cunningham
DIS	Distributors Corporation Pty. Ltd.	STC	Standard Telephone & Cables
ELN	Elna Capacitors (Sonar Elec. P/L)	SI	Siemens Electrical Industries
ETD	Electron Tube Dist.	SIM	Simonson Pty. Ltd.
F	Fairchild Australia Pty. Ltd.	SE	Selectronic Components
GRA	General Radio Agencies	SON	Sonar Electronics
GE	General Electric (USA)	TR	Trimax Erricson Transformers
GEC	General Electric Co. (UK)	TI	Texas Instruments Pty. Ltd.
GES	General Electronic Services	TH	Thorn Atlas
HW	Hurtle Webster	UC	Union Carbide
HOL	R. G. Holloway	W	Wellyn Resistors (Cannon Elec. P/L)
H	Haco Distributors (National)	WH	Westinghouse
HS	Hawker Sidney	Z	Zephyr Prod. Pty. Ltd.

PARTS LIST - MODEL bwd 539A

ITEM NO.	DESCRIPTION				Mfr or Supply	PART NO.
R145	33KΩ	5%	1W	CC	PI	
R145A	270KΩ	5%	½W	CC	PI	
R146	390Ω	5%	½W	CC	PI	
R147	33KΩ	5%	1W	CC	PI	
R148	39KΩ	5%	½W	CC	PI	
R149	8.2KΩ	5%	½W	CC	PI	
R150	47KΩ	5%	½W	CC	PI	
R151	4.7KΩ	5%	½W	CC	PI	
R152	1KΩ	5%	1W	CC	PI	
R153	1KΩ	5%	1W	CC	PI	
R154						
R155	4.7KΩ	5%	1W	CC	PI	
R156	470Ω	5%	½W	CC	PI	
R157	330Ω	5%	½W	CC	PI	
R158	330Ω	5%	½W	CC	PI	
R159	330Ω	5%	½W	CC	PI	
R160	2.2MΩ	5%	½W	CC	PI	
R161	820K	5%	½W	CC	PI	
R162	100KΩ	5 or 10%	½W	C	MOR	
R201	1MΩ	5%	½W	CC	PI	
R202	1MΩ	5%	½W	CC	PI	
R203	1MΩ	5%	½W	CC	PI	
R204	1MΩ	5%	½W	CC	PI	
R105	68KΩ	5%	½W	CC	PI	
R207	10KΩ	5%	½W	CC	PI	
R208	100KΩ	5%	½W	CC	PI	
R209	1.8MΩ	5%	½W	CC	PI	
R210	27KΩ	5%	½W	CC	PI	
R211	27KΩ	5%	½W	CC	PI	
	<u>POTENTIOMETERS</u>					
RV1	220KΩ LIN. POT WITH DPST			C	PH	2322-357727-12
RV2	1KΩ TRIM POT			C	PH	2322-411-02204
RV3	250K LIN. POT			C	SOR	VCU
RV4	1KΩ TRIM POT			C	PH	2322-411-02204
RV5	100Ω TRIM POT			C	PH	2322-411-02201

PARTS LIST - MODEL bwd 539A

ITEM NO.	DESCRIPTION				Mfr or Supply	PART NO.
C21	47pF	500V	5%	NPO	H.S	CDS
C22	33uF	40V		ELECTR.	PH	2222-015-17339
C23						
C24	0.1uF	100V	10%	GREEN-C	ELNA	TYPE N
C25	150uF	16V		ELECTR.	PH	2222-016-15151
C26	270pF	630V	5%	PYS	H.S	TCS605
C27	20-220pF	TRIM			DUC	CWO
C28	0.001uF	500V	5%	NPO	H.S	CDS
C29	0.001uF	500V	5%	NPO	H.S	CDS
C30	0.1uF	400V	10%	PYE	PH	2202-315-51104
C31	5.6pF	500V	10%	NPO	H.S	CDS
C32	1-12pF	TRIM			PH	C004CA/12E
C32A	15pF	500V	10%		H.S	CDS
C33	1-12pF	TRIM			PH	C004CA/12E
C34	15pF	500V	5%	NPO	H.S	CDS
C35	0.8-3pF	TRIM			PH	C004AA/3E
C36	1-12pF	TRIM			PH	C004CA/12E
C36A	15pF	500V	10%		H.S	CDS
C37	470pF	500V	5%	SM	DUC	MSA
C38	0.0047uF	400V	10%	PYE	PH	2202-315-51472
C39	1-12pF	TRIM			PH	C004CA/12E
C39A	3.3pF	500V	10%		H.S	CDS
C40	1-12pF	TRIM			PH	C004CA/12E
C41	1-12pF	TRIM			PH	C004CA/12E
C42	1-12pF	TRIM			PH	C004CA/12E
C43	33PF	500V	5%	NPO	HS	CDS
C44	8.2pF	500V	5%	NPO	HS	CDS
C45	4.5/20pF	TRIM			RHC	7S/02
C46	0.0022uF	500V	5%	NPO	HS	CDS
C47	220uF	16V		ELECTR.	PH	2222-016-15221
C48	10-40pF	TRIM			STET	10S-06/10-40
C49	0.1uF	100V	10%	GREENCAP	ELNA	TYPE N
C50	100 pF	500V	5%	NPO	HS	CDS
C51	100pF	500V	5%	NPO	HS	CDS
C52	0.0033uF	400V	10%	PYE	PH	
C53	100pF	500V	5%	NPO	HS	CDS
C54	100pF	500V	5%	NPO	HS	CDS
C55	560pF	630V	5%	PYS	HS	TCS609
C56	100uF	40V		ELECTR.	PH	2222-016-17101
C57						
C58	10-40 pF	TRIMMER			STET	10S-06/10-40
C59						
C60	10pF	500V	5%	NPO	HS	CDS
C61	0.22uF	100V	10%	GREEN C	ELNA	TYPE N
C62	0.001uF	500V	10%		HS	CDS
C63	33pF	500V	5%	NPO	HS	CDS
C64	0.1uF	100V	10%	GREEN C	SON	

PARTS LIST - MODEL bwd 539A

ITEM NO.	DESCRIPTION			Mfr or Supply	PART NO.	
RV6	220Ω TRIM POT.		C	PH	2322-411-02202	
RV7	220Ω TRIM POT.		C	PH	2322-411-02202	
RV8	4.7K TRIM POT.		C	PH	2322-411-02206	
RV9	220K LIN. POT WITH DPST		SW	PH	2322-357727-12	
RV10	22KΩ TRIM POT.		C	PH	2322-411-02208	
RV11	220K LIN. POT. WITH SPST		SW	PH	2322-357727-12	
RV12	100KΩ TRIM POT.		C	PH	2322-411-02211	
RV13	4.7KΩ TRIM POT.		C	PH	2322-411-02206	
RV14A	100KΩ LIN. POTS.		C	1RH		
RV14B	10KΩ		C	1RH		
RV15	22KΩ TRIM POT.		C	PH	2322-411-02208	
RV16	1KΩ TRIM POT.		C	PH	2322-411-02204	
RV17	470KΩ TRIM POT.		C	PH	2322-411-02213	
RV18	100KΩ TRIM POT.		C	PH	2322-411-02211	
RV19	1MΩ LIN. POT.		C	SOR	VCU	
RV20	1KΩ TRIM POT.		C	PH	2322-411-02204	
RV21	100Ω TRIM POT.		C	PH	2322-411-02201	
RV22			C	PH	2322-411-02204	
RV23	100Ω TRIM POT.		C	PH	2322-411-02201	
RV24	220KΩ LIN. POT. WITH DPST		SW	PH	2322-357727-12	
RV25	1KΩ TRIM POT.		C	PH	2322-411-02205	
RV201	4.7KΩ TRIM POT.		C	PH	2322-411-02206	
RV206	100K TRIM POT.		C	PH	2322-411-02211	
<u>CAPACITOR</u>						
C1	0.1uF	400V	10%	PYE	PH	2202-315-51104
C2	5.6pF	500V	10%	NPO	H.S	CDS
C3	1-12pF	TRIM			PH	C004CA-12E
C3A	15pF	500V	10%			
C4	1-12pF	TRIM			PH	C004CA-12E
C5	15pF	500V	10%	NPO	H.S	CDS
C6	0.8-3pF	TRIM			PH	C004AA/3E
C7	1-12pF	TRIM			PH	C004CA-12E
C7A	15pF	500V	10%			
C8	470pF	500V	5%	SM	DUC	MSA
C9	0.0047uF	400V	10%	PYE	PH	
C10	1-12pF	TRIM				
C10A	3.3pF	500V	10%			
C11	1-12pF	TRIM			PH	C004CA/12
C12	1-12pF	TRIM			PH	C004CA/12E
C13	33pF	500V	10%	N750	H.S	CDS
C14	8.2pF	500V	10%			
C15	1-12pF	TRIM			PH	C004CA/12E
C16	4.5/20pF	TRIM			STET	7S-02
C17	0.0022uF	500V	10%	NPO		CDS
C18	0.01uF	100V	10%	GREEN CAP	ELNA	TYPE N
C19	0.1uF	100V	10%	GREEN CAP	ELNA	TYPE N
C20	150uF	16V		ELECT.	PH	2222-016-15151

PARTS LIST - MODEL bwd 539A

ITEM NO.	DESCRIPTION				Mfr or Supply	PART NO.	
C65	0.01 $\mu$ F	100V	10%	GREEN C	SON		
C66	4.7 $\mu$ F	63V		ELECTR.	PH	2222-015-18478	
C67	10 $\mu$ F	25V		ELECTR.	PH	2222-015-15109	
C68	0.022 $\mu$ F	160V		PYE	PH		
C69	2.2 $\mu$ F	63V		PH	PH	2222-015-18228	

PARTS LIST - MODEL bwd 539A

ITEM NO.	DESCRIPTION				Mfr or Supply	PART NO.
C70	10-40PF	TRIM			STETNER	10S-06,10-40
C71	82PF	500V	5%		H.S	CDS
C72	0.01uF	100V		SELECT 2%	ELNA	TYPE N
C73A )	1 uF	200V		GREEN CAP	ELNA	TYPE N
C73B )				SELECT FOR 2%		
C74	1uF	200V	10%	GREEN	SON	TYPE N
C75						
C76	15pF	500V	5%	NPO	H.S	CDS
C77	0.1uF	100V	10%	GREEN CAP	SON	TYPE N
C78	220pF	630V	5%	PYS	H.S	TCS604
C79	0.01	100V	10%	GREEN CAP	ELNA	TYPE N
C80	220pF	500V	5%	N750	H.S	CDS
C81	22pF	500V	5%	N750	H.S	CDS
C82	47pF	500V	5%	N750	H.S	CDS
C82A	100pF	500V	5%	N750	H.S	CDS
C83	0.01uF	100V	10%	GREEN C	ELNA	TYPE N
C84	4.5-20pF	TRIM			STET	75-02
C85	220pF	630V	5%	PYS	H.S	TCS 604
C86	50uF	150V		ELECTR.	PH	2222-040-11509
C87	50uF	150V		ELECTR.	PH	2222-040-11509
C88	40uF	200V		ELECTR.	PH	2222-040-12409
C89	40uF	200V		ELECTR.	PH	2222-040-12409
C90	100uF	63V		ELECTR.	PH	2222-017-18101
C91	220uF	63V		ELECTR.	PH	2222-017-18221
C92	220uF	63V		ELECTR.	PH	2222-017-18221
C93	100uF	63V		ELECTR.	PH	2222-017-18101
C94	100uF	63V		ELECTR.	PH	2222-017-18101
C95	100uF	63V		ELECTR.	PH	2222-017-18101
C96	22pF	500V	10%	N750	H.S	CDS
C96A	10pF	500V	10%	N750	H.S	CDS
C97						
C83A	33pF	500V	5%	CER	H.S	CDS
C201	8uF	450V		ELECTR.	DUC	
C202	8uF	450V		ELECTR.	DUC	
C203	8uF	450V		ELECTR.	DUC	
C204	8uF	450V		ELECTR.	DUC	
C205	0.1uF	1600V	20%	MHT	DUC	DUOSEAL
C206						
C207	0.01uF	3000V		C DISK	DUC	CDH
C208	0.1uF	160V	10%	PYE	PH	2202-315-31104
C209	0.1uF	1600V	20%	MHT	DUC	DUOSEAL
C210	0.01uF	3000V		C DISK	DUC	CDH
C211	220pF	2000V	10%	C DISK	DUC	CDH
C212	0.001	500V	10%	H1K	H.S	CDS

PARTS LIST - MODEL bwd 539A

ITEM NO	DESCRIPTION	Mfr or Supply	PART NO.
<u>DIODES</u>			
D1-D2 ) D7-D8 )	AN210	F	
D9-D19 ) D3-D6 )	75V PIV 30MA S1	F	AN206
D20-D23	400V PIV 500MA S1	STC	EM404
D201	SELENIUM RECT.	STC	K8/25
D202	SELENIUM RECT.	STC	K8/25
D203	SELENIUM RECT.	STC	K8/25
D204	SELENIUM RECT.	STC	K8/25
D205	75V PIV 30MA	F	AN206
D14A	33V ZENER	F	AN973B
<u>SWITCHES</u>			
S1	2 POLE 2 POS.	SATO	SATO3570
S2A-D	4 POLE 12 POS.	BWD	SR73
S3	2 POLE 2 POS.	SATO	SATO3570
S4A-D	4 POLE 12 POS.	BWD	SR73
S5A&B	2 POLE 2 POS.	SATO	SATO3570
S6	2 POLE 2 POS. (REAR OF RV7)		
S7	2 POLE 2 POS.	McM	1299-02-01
S8A&B	2 POLE 2 POS.	McM	1299-02-01
S9A&B	2 POLE 2 POS.		
S10A&B	2 POLE 2 POS. (REAR OF RV9)		
S11A-D	4 POLE 18 POS.	BWD	SR72
S12A&B	2 POLE 2 POS. (REAR OF RV11)		
S13A&B	2 POLE 2 POS. (REAR OF RV19)		
S14	2 POLE 2 POS. ISOSTAT SWITCH	McM	934/1-SR80
<u>SUNDRY</u>			
V1	CRT5"	PH	D13-27GH
B1	NEON LAMP	SATO	
F1	500MA CARTRIDGE FUSE Q/B	Y	
T1	POWER TRANSFORMER.	BWD	TP5698
	CRT MAGN. SHIELD.	BWD	DRG632
ALL OTHER ITEMS ORDER BY DESCRIPTION			

PARTS LIST - MODEL bwd 539A

ITEM NO.	DESCRIPTION	Mfr or Supply	PART NO.	
	<u>SEMI-CONDUCTOR</u>			
Q1,2	25V DS N CHANNEL FET	S1	NS	2N3819 or MPF106
Q11,12	MATCHED QUAD			
Q3	25 Vce Hfe 100 NPN	S1	PH	BF194
Q4	25 Vce Hfe 100 NPN	S1		BF194
Q5	25 Vce Hfe 100 NPN	S1	PH	BF194
Q6	25 Vce Hfe 100 NPN	S1	PH	BF194
Q7	25 Vce Hfe 100 NPN	S1	PH	BF194
Q8	25 Vce Hfe 100 NPN	S1	PH	BF194
Q9	150Vce Hfe 40 NPN	S1	PH	BF336
Q10	150Vce Hfe 40 NPN	S1	PH	BF336
Q13	25Vce Hfe 100 NPN	S1	PH	BF194
Q14	25Vce Hfe 100 NPN	S1	PH	BF194
Q15	25Vce Hfe 100 NPN	S1	PH	BF194
Q16	25Vce Hfe 100 NPN	S1	PH	BF194
Q17	45Vce Hfe 100 NPN	S1	PH	BF147
Q18	45Vce Hfe 100 NPN	S1	PH	BC147
Q19	45Vce Hfe 100 NPN	S1	PH	BC147
Q20	45Vce Hfe 100 NPN	S1	PH	BC147
Q21	45Vce Hfe 100 NPN	S1	PH	BC147
Q22	45Vce Hfe 100 NPN	S1	PH	BC147
Q23	45Vce Hfe 100 NPN	S1	PH	BC147
Q24	45Vce Hfe 100 NPN	S1	PH	BC147
Q25	45Vce Hfe 100 NPN	S1	PH	BC147
Q26	-45Vce Hfe 75 PNP	S1	PH	BC157
Q27	25VDS N CHANNEL FET	S1	TI	2N3819 or MPF106
Q28	45Vce Hfe 100 NPN	S1	PH	BC147
Q29	45Vce Hfe 100 NPN	S1	PH	BC147
Q30	45Vce Hfe 100 NPN	S1	PH	BC147
Q31	250 Vce Hfe 40 NPN	S1	PH	BF337
Q32	250 Vce Hfe 40 NPN	S1	PH	BF337
Q33	-45 Vce Hfe 50 PNP	S1	PH	BC157
Q201	-25Vce Hfe 100 PNP	S1	F	AY1114
IC1	UA702C AMPLIFIER		F	UA702C



R	MODIFICATIONS
84	ISSUE 2 - 6/72 R19A, 57A ADDED TO FET GATES.
C	ISSUE 3 28-6-72 Q15/16 BF194 TO BC209B
Q	C23 39pf TO 68pf
18 TO 201	R24/63 470Ω TO 390Ω
D	C48 68pf TO 95pf
14	ISSUE 4 - 17-7-72 C23 68pf TO 33pf C48 95pf TO 68pf
	ISSUE 5 6-12-72 Q15/16 BC209B TO BF194 C48 68pf TO 10-40pf VAR C23 REMOVED C25 & C26 ADDED IN SERIES WITH C48 AND C58.
	ISSUE 6 12-72 C20 125/16 TO 150/16 C22 32/64 TO 33/40 C25 125/16 TO 150/16 C47 250/16 TO 220/16

SWITCHES

S1 AC-DC INPUT CHANNEL 'A'  
 S2A-D ATTENUATOR CHANNEL 'A'  
 S3 AC-DC INPUT CHANNEL 'B'  
 S4A-D ATTENUATOR CHANNEL 'B'  
 S5 A&B ALTERNATE - CHOPPED.  
 S6 CHANNEL A ON-OFF (REAR RV7)  
 S14 TRIGGER SELECT.

CONTROLS

RV1 VERTICAL POSITION CHANNEL 'A'  
 RV2 CALIBRATE " 'A'  
 RV3 VERTICAL POSITION " 'B'  
 RV4 CALIBRATE " 'B'  
 RV5 AMPLIFIER RESPONSE  
 RV6 DC BALANCE 'B'  
 RV7 DC BALANCE 'A'  
 RV8 SET I.C. VOLTAGE.  
 RV201 SET CALIBRATE SIGNAL.  
 RV21 MAINS BALANCE.  
 RV22 TRIGGER BALANCE CONTROL.  
 RV23 MAINS BALANCE.  
 RV25 AMPLIFIER RESPONSE CHANNEL 'A'  
 RV26 AMPLIFIER RESPONSE CHANNEL 'B'

ATTEN .2V/cm ON CHANNEL A & B.  
 T1B 2 m/s/cm, VERNIER CAL, TRIG 'B', NORM, + INT, ALT.

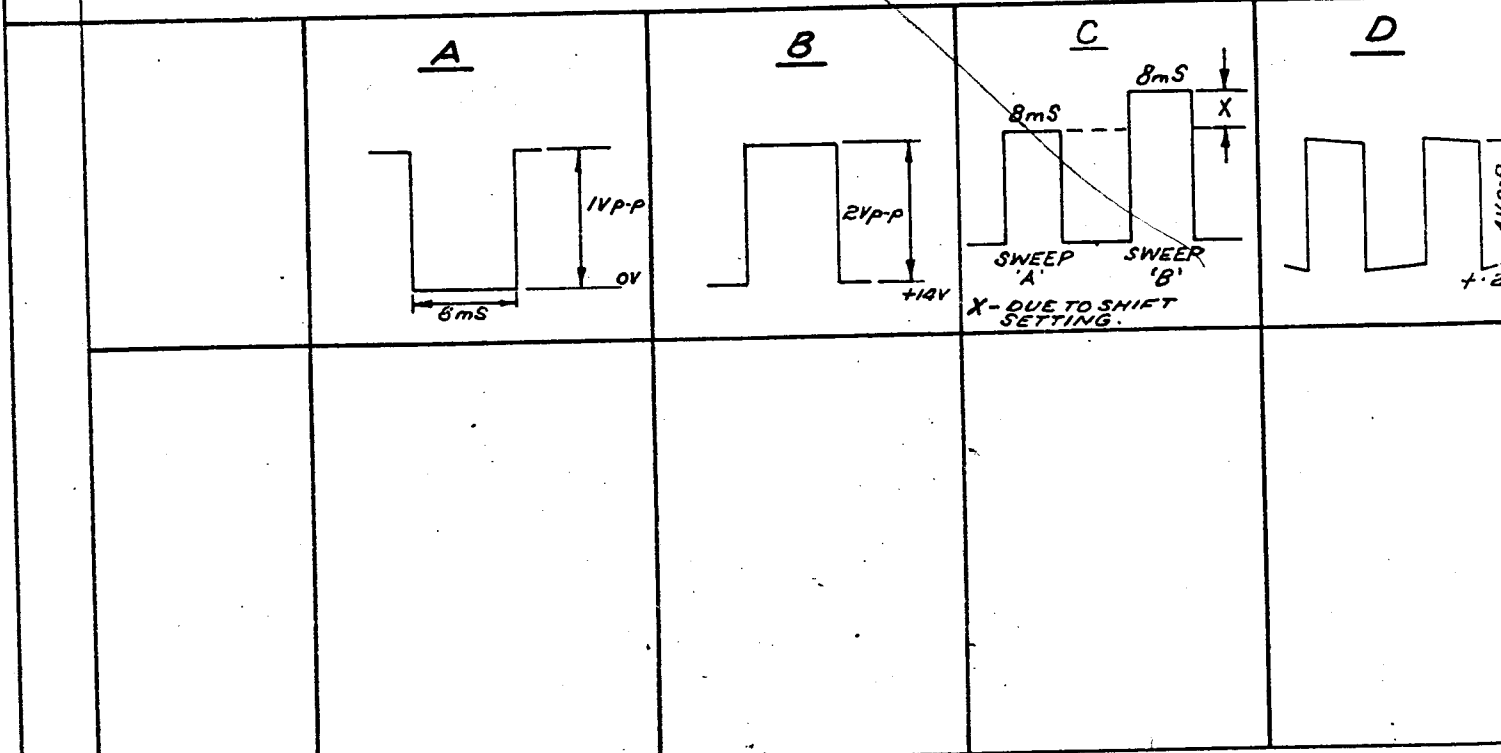

MODIFICATIONS	
R 84	ISSUE 2 - 6/72 R19A, 57A ADDED TO RET. GATES.
C 58	ISSUE 3 28-6-72 Q15/16 BF194 TO BC209B
Q 18 TO 201	C23 39pf TO 68pf R24/03 470Ω TO 390Ω
D 14	C48 68pf TO 95pf
	ISSUE 4 - 17-7-72 C23 68pf TO 33pf C48 95pf TO 68pf
	ISSUE 5 6-12-72 Q15/16 BC209B TO BF194 C48 68pf TO 10-40pf VAR C23 REMOVED C25 & C26 ADDED IN SERIES WITH C48 AND C58.
	ISSUE 6 12-72 C20 125/16 TO 150/16 C22 32/64 TO 33/40 C25 125/16 TO 150/16 C47 250/16 TO 220/16

SWITCHES

- S1 AC-DC INPUT CHANNEL 'A'
- S2A-D ATTENUATOR CHANNEL 'A'
- S3 AC-DC INPUT CHANNEL 'B'
- S4A-D ATTENUATOR CHANNEL 'B'
- S5 A&B ALTERNATE - CHOPPED.
- S6 CHANNEL A ON-OFF (REAR RV7)
- S14 TRIGGER SELECT.

CONTROLS

- RV1 VERTICAL POSITION CHANNEL 'A'
- RV2 CALIBRATE " 'A'
- RV3 VERTICAL POSITION " 'B'
- RV4 CALIBRATE " 'B'
- RV5 AMPLIFIER RESPONSE
- RV6 DC BALANCE 'B'
- RV7 DC BALANCE 'A'
- RV8 SET I.C. VOLTAGE.
- RV201 SET CALIBRATE SIGNAL.
- RV21 MAINS BALANCE.
- RV22 TRIGGER BALANCE CONTROL.
- RV23 MAINS BALANCE.
- RV25 AMPLIFIER RESPONSE CHANNEL 'A'
- RV26 AMPLIFIER RESPONSE CHANNEL 'B'

ATTEN .2V/cm ON CHANNEL A & B.  
T/B 2m/s/cm, VERNIER CAL, TRIG 'B', NORM, + INT, ALT.

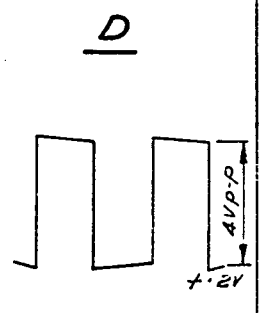
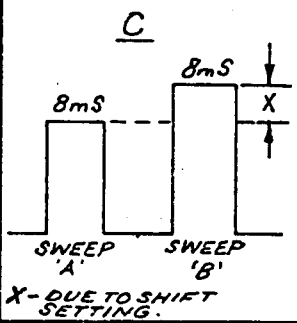
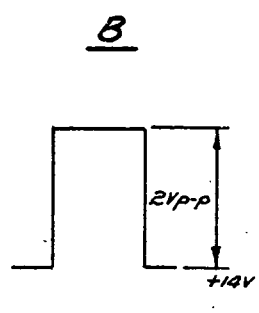
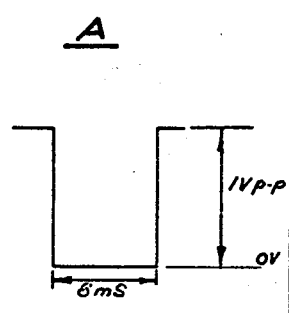

<b>R</b> 90- 161	<b>MODIFICATIONS</b> <u>ISSUE 2 6-72</u> C83A ADDED
<b>C</b> 60- 97	R145A ADDED <u>ISSUE 3 6-72</u> C84 12pf to 4-10pf
<b>D</b> 15- 25	<u>ISSUE 4 11-72</u> C80 100pf to 220pf
<b>Q</b> 19- 33	<u>ISSUE 5 12-72</u> C90 100/64 to 100/63 C91 160/64 to 220/63 C92 150/64 to 220/63 C93 100/64 to 100/63 C94 100/64 to 100/63 C95 100/64 to 100/63
	<u>ISSUE 6 2-73</u> C80 220pf to 100pf

SWITCHES

- S7 INT - EXT TRIGGER
- S8 A & B + OR -
- S9 A & B NORM - TV SELECT
- S10 A & B AUTO - SELECT (REAR RV9)
- S11 A - D TIME BASE RANGE
- S12 A & B INT - EXT TIME BASE (REAR RV11)
- S13 A & B POWER ON & OFF (REAR RV19)

CONTROLS

- RV9 TRIGGER LEVEL SELECT.
- RV10 TRIGGER SENSITIVITY.
- RV11 TIME BASE VERNIER
- RV12 TIME BASE CALIBRATE.
- RV13 TRACE LENGTH
- RV14A HORZ POSITION
- RV14B HORZ MAGNIFICATION
- RV15 X5 MAG. CAL.
- RV16 HORZ CENTREING
- RV17 CRT GEOMETRY
- RV18 ASTIGMATISM
- RV19 FOCUS
- RV20 T/B DC LEVEL.
- RV24 INTENSITY.

ATTEN .2Vp/cm. ON CHAN A & B.

T/B 2mS/cm, VERN, CAL, TRIG B, NORM, + INT, ALT.

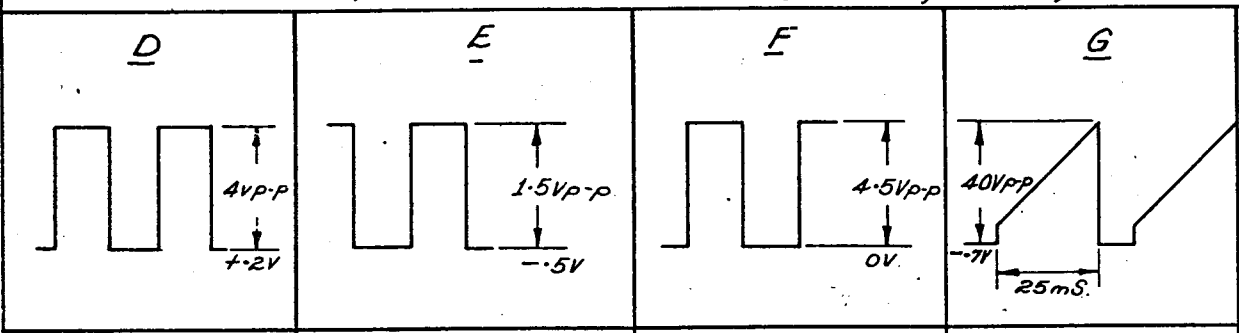

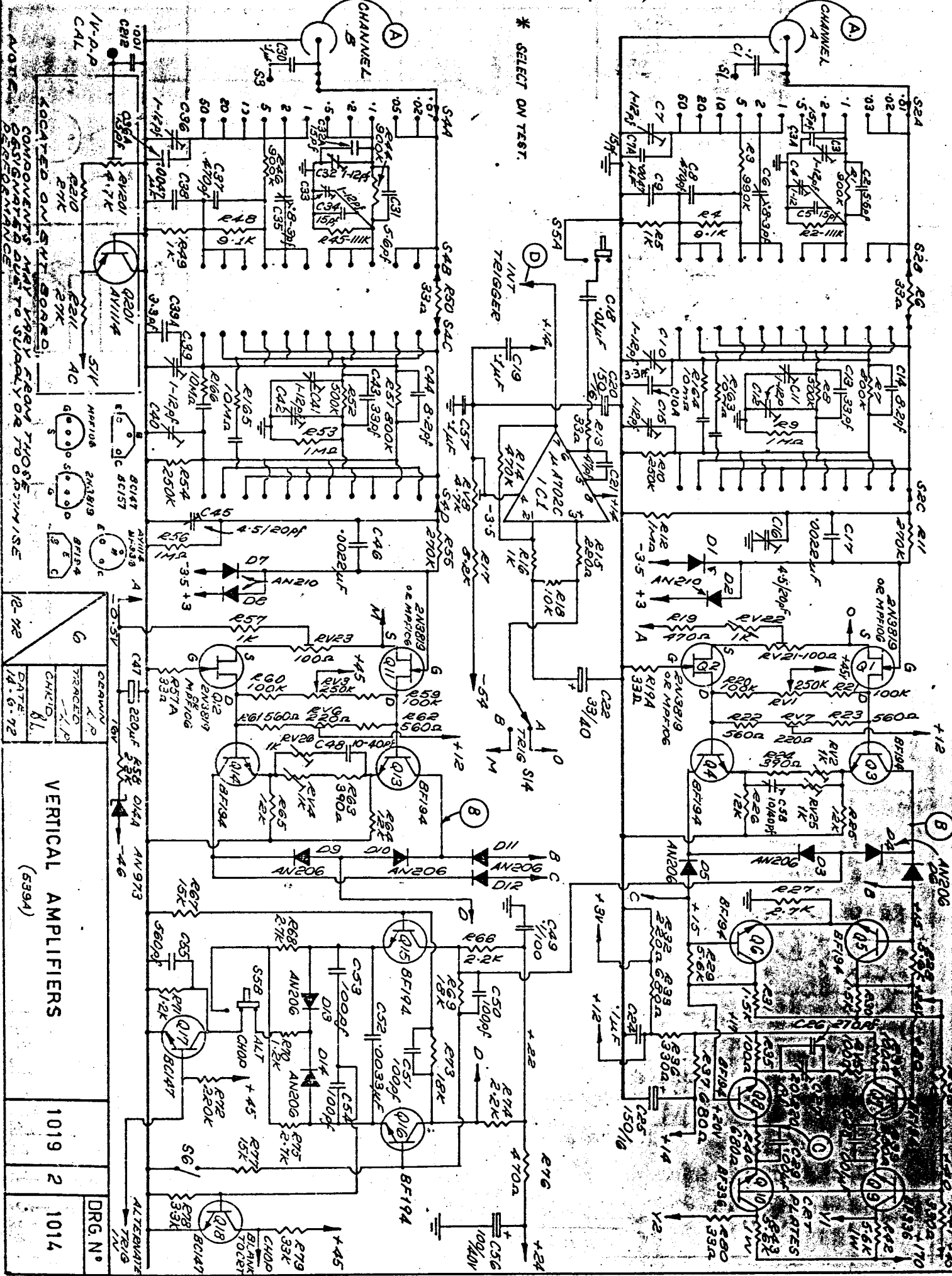

\* SELECT ON TEST.

LOCATED ON SHIT BOARD  
COMPONENTS MAY VARY FROM THOSE DESIGNATED DUE TO SLIGHTLY OR TO OTHERWISE

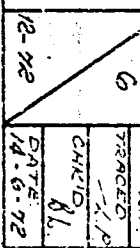

VERTICAL AMPLIFIERS  
(5394)

1019 2 1014  
DRG N°





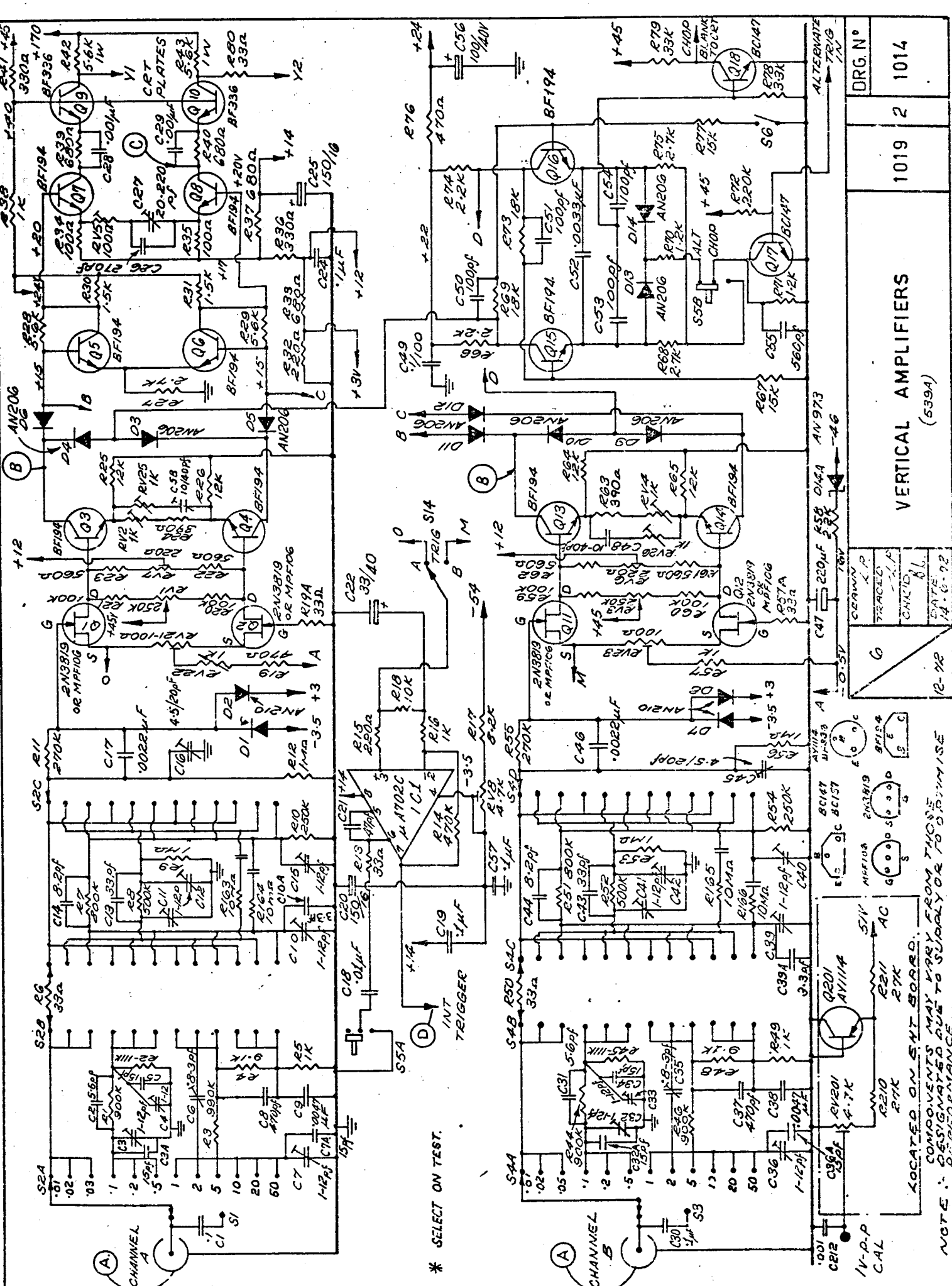

\* SELECT ON TEST.

VERTICAL AMPLIFIERS

(539A)

DRG. N°	1019	2	1014
DATE	12-12		
DESIGNED BY			
CHECKED BY			
TRACED BY			
REVIEWED BY			

LOCATED ON FRONT BOARD.  
 COMPONENTS MAY VARY FROM THOSE  
 SHOWN DUE TO SUPPLY OR TO DISCREPANCY  
 NOTE: DESIGNOR'S RESPONSIBILITY

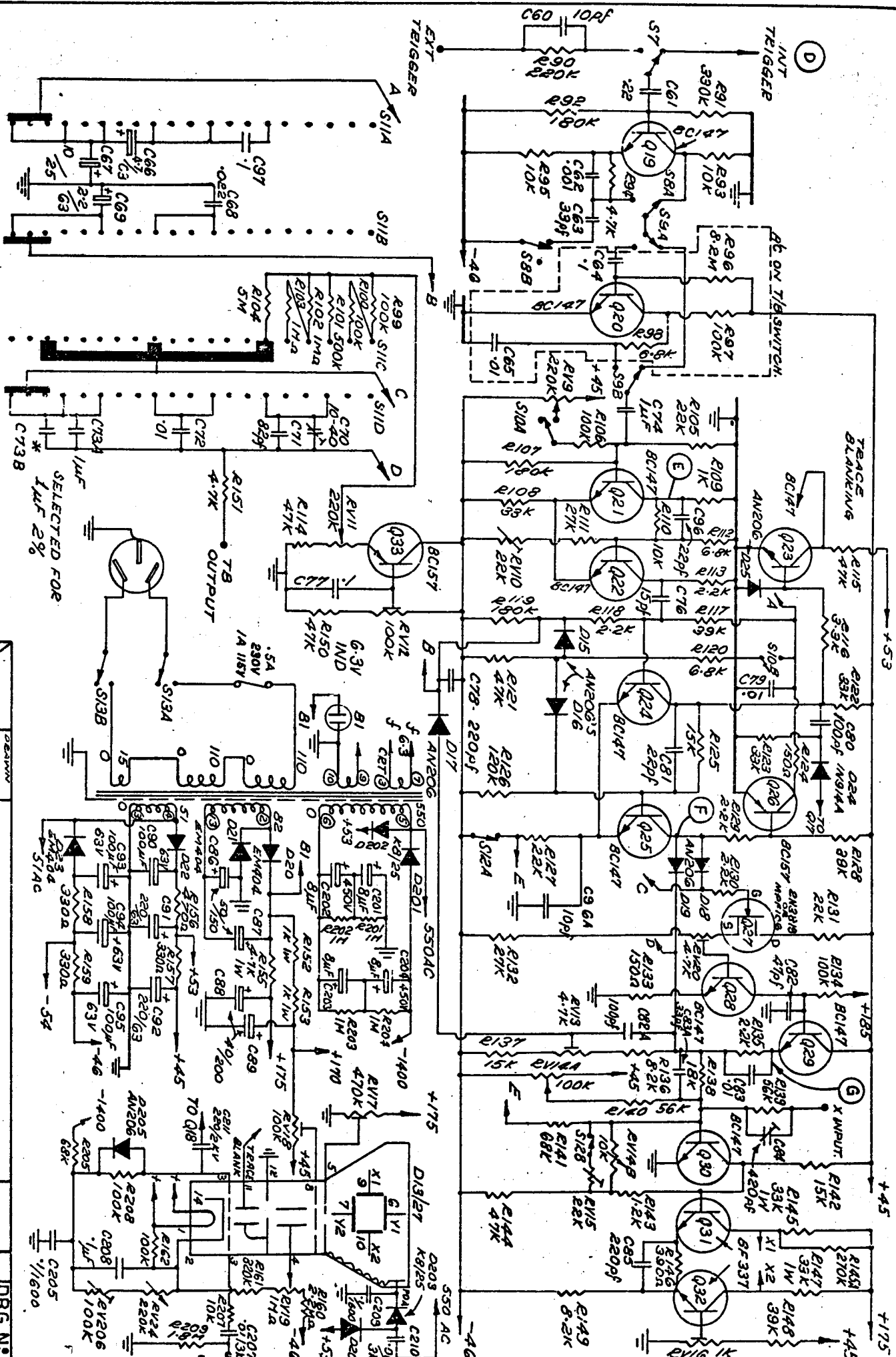

**TIME BASE & POWERSUPPLIES**

539A

DRG. NO.	1019
1014	2

5-73

BEAMV L.P. TARGETED L.P. CHA:10 B.L. GATE 3A-2-712

DF337 AV114

AC157 BC147 MPF106 2N3919

SELECTED FOR 1μF 2%

OUTPUT TB

5A 230V 1A 115V

550 AC

D205 AN206

D207 0.13KV

D208 100K

D209 10K

D210 10K

D211 10K

D212 10K

D213 10K

D214 10K

D215 10K

D216 10K

D217 10K

D218 10K

D219 10K

D220 10K

D221 10K

D222 10K

D223 10K

D224 10K

D225 10K

D226 10K

D227 10K

D228 10K

D229 10K

D230 10K

D231 10K

D232 10K

D233 10K

D234 10K

D235 10K

D236 10K

D237 10K

D238 10K

D239 10K

D240 10K

D241 10K

D242 10K

D243 10K

D244 10K

D245 10K

D246 10K

D247 10K

D248 10K

D249 10K

D250 10K

D251 10K

D252 10K

D253 10K

D254 10K

D255 10K

D256 10K

D257 10K

D258 10K

D259 10K

D260 10K

D261 10K

D262 10K

D263 10K

D264 10K

D265 10K

D266 10K

D267 10K

D268 10K

D269 10K

D270 10K

D271 10K

D272 10K

D273 10K

D274 10K

D275 10K

D276 10K

D277 10K

D278 10K

D279 10K

D280 10K

D281 10K

D282 10K

D283 10K

D284 10K

D285 10K

D286 10K

D287 10K

D288 10K

D289 10K

D290 10K

D291 10K

D292 10K

D293 10K

D294 10K

D295 10K

D296 10K

D297 10K

D298 10K

D299 10K

D300 10K

D301 10K

D302 10K

D303 10K

D304 10K

D305 10K

D306 10K

D307 10K

D308 10K

D309 10K

D310 10K

D311 10K

D312 10K

D313 10K

D314 10K

D315 10K

D316 10K

D317 10K

D318 10K

D319 10K

D320 10K

D321 10K

D322 10K

D323 10K

D324 10K

D325 10K

D326 10K

D327 10K

D328 10K

D329 10K

D330 10K

D331 10K

D332 10K

D333 10K

D334 10K

D335 10K

D336 10K

D337 10K

D338 10K

D339 10K

D340 10K

D341 10K

D342 10K

D343 10K

D344 10K

D345 10K

D346 10K

D347 10K

D348 10K

D349 10K

D350 10K

D351 10K

D352 10K

D353 10K

D354 10K

D355 10K

D356 10K

D357 10K

D358 10K

D359 10K

D360 10K

D361 10K

D362 10K

D363 10K

D364 10K

D365 10K

D366 10K

D367 10K

D368 10K

D369 10K

D370 10K

D371 10K

D372 10K

D373 10K

D374 10K

D375 10K

D376 10K

D377 10K

D378 10K

D379 10K

D380 10K

D381 10K

D382 10K

D383 10K

D384 10K

D385 10K

D386 10K

D387 10K

D388 10K

D389 10K

D390 10K

D391 10K

D392 10K

D393 10K

D394 10K

D395 10K

D396 10K

D397 10K

D398 10K

D399 10K

D400 10K

D401 10K

D402 10K

D403 10K

D404 10K

D405 10K

D406 10K

D407 10K

D408 10K

D409 10K

D410 10K

D411 10K

D412 10K

D413 10K

D414 10K

D415 10K

D416 10K

D417 10K

D418 10K

D419 10K

D420 10K

D421 10K

D422 10K

D423 10K

D424 10K

D425 10K

D426 10K

D427 10K

D428 10K

D429 10K

D430 10K

D431 10K

D432 10K

D433 10K

D434 10K

D435 10K

D436 10K

D437 10K

D438 10K

D439 10K

D440 10K

D441 10K

D442 10K

D443 10K

D444 10K

D445 10K

D446 10K

D447 10K

D448 10K

D449 10K

D450 10K

D451 10K

D452 10K

D453 10K

D454 10K

D455 10K

D456 10K

D457 10K

D458 10K

D459 10K

D460 10K

D461 10K

D462 10K

D463 10K

D464 10K

D465 10K

D466 10K

D467 10K

D468 10K

D469 10K

D470 10K

D471 10K

D472 10K

D473 10K

D474 10K

D475 10K

D476 10K

D477 10K

D478 10K

D479 10K

D480 10K

D481 10K

D482 10K

D483 10K

D484 10K

D485 10K

D486 10K

D487 10K

D488 10K

D489 10K

D490 10K

D491 10K

D492 10K

D493 10K

D494 10K

D495 10K

D496 10K

D497 10K

D498 10K

D499 10K

D500 10K