

INSTRUCTION & OPERATION

MANUAL FOR

Model 3316A
Filter Coupler

Model 3316 Filter Coupler

Specifications

Frequency Band 962 MHz to 1213 MHz

Input Wave Form Gaussian shaped pluses
 Width between 50% amplitude points
 3.5 ±0.5 us
 Rise and fall times between 10% and 90%
 amplitude points: 2.5 ±0.5 us
 Pulse Repetition Frequency: 24 pps min.

Power Range 5000 W peak forward power

Output signal 0 to 5V DC into 10K ohm min. for FS

Insertion Loss 0.3 dB Max. into 50 ohm line

Insertion VSWR 1.4/1 Max. into 50 ohm line

L.P. Filter Attenuation . . 30dB min. 1920 MHz to 2650 MHz

Accuracy The coupler together with its display
 shall meet the accuracies specified in
 the following table, over the tempera-
 ture range of -10°C to +85°C and the
 frequency range of 1025 MHz to 1150 MHz.

SCALE	RANGE	RANGE ACCURACY
5 kW FWD	0.4 to 0.7 kW	±1.7 dB
	0.7 to 1.0 kW	±1.2 dB
	1.0 to 1.5 kW	±0.8 dB
	1.5 to 4.0 kW	±0.6 dB
	4.0 to 5.0 kW	±0.8 dB

DC Power Input +15 DC ±3% @ 25 ma (A)
 -15 DC ±3% @ 35 ma (B)

Overload Capability 20W Max. Average Power, C.W.
 5 kW Max. Peak Power Pulsed

Bird Electronic Corp.
 30303 Aurora Road
 Cleveland (Solon), Ohio 44139

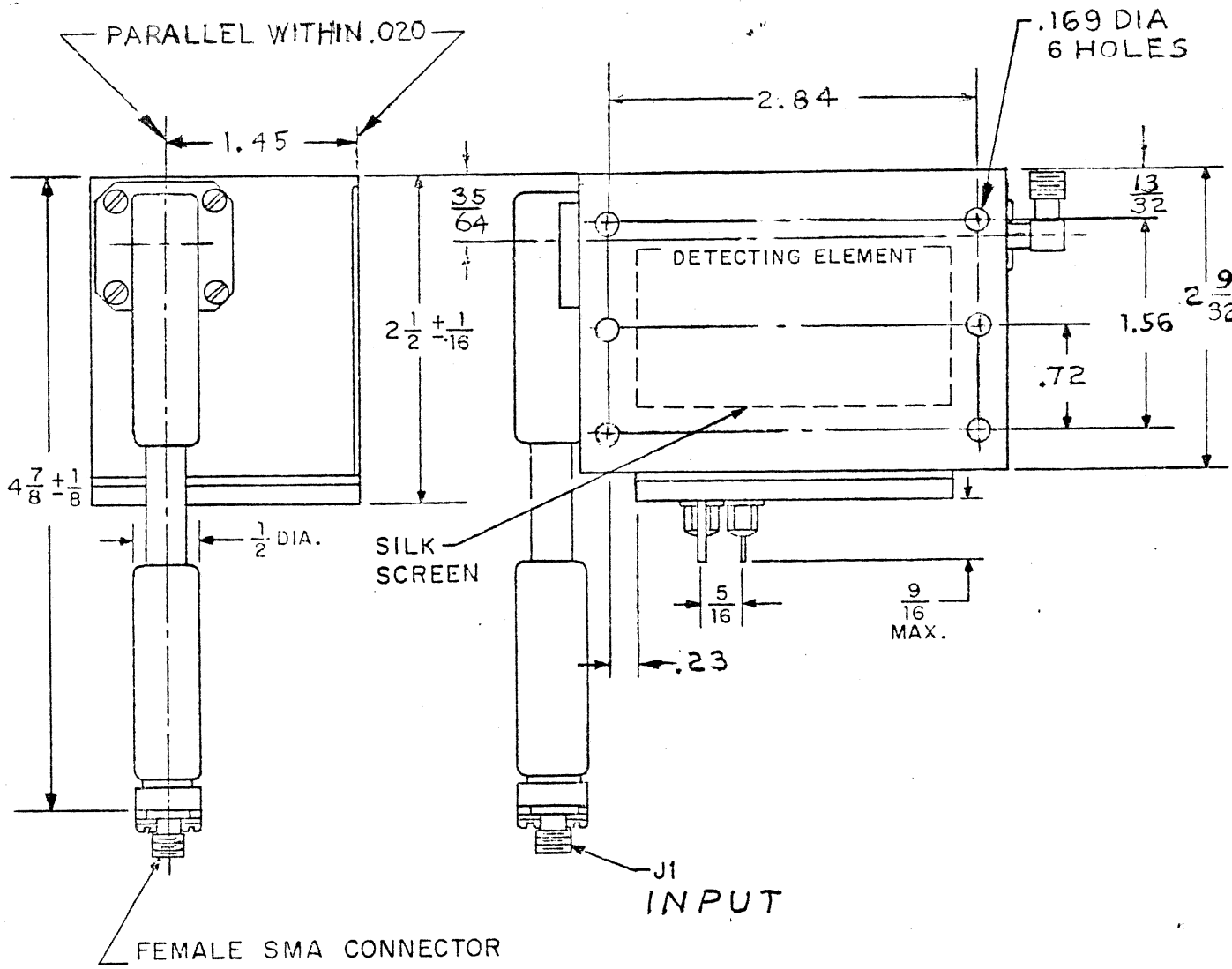

NOTES:

- 1. A = +15VDC
- B = -15VDC
- C = GND
- D = OUTPUT

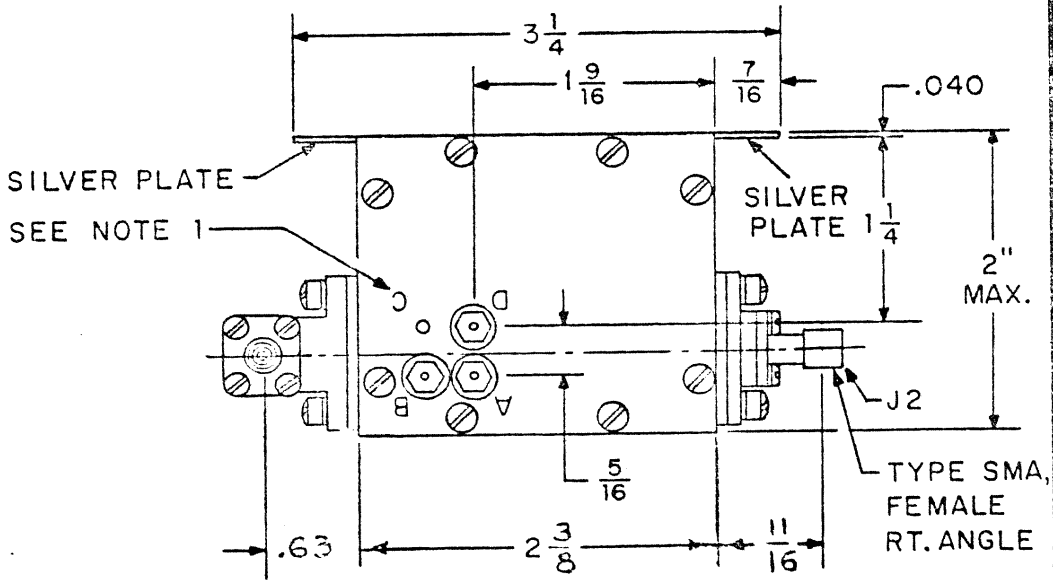

FIGURE 1. OUTLINE AND MOUNTING DIMENSION.

TABLE OF CONTENTS

<u>Para.</u>	<u>Title</u>	<u>Page</u>
1.0	Purpose	1
2.0	Scope	1
3.0	Functional Description	1
3.1	Low-Pass Filter	1
3.2	Line Section	2
3.3	Coupler	2
3.4	Peak-Reading Operational Amplifier	2
3.5	RFI Filters and Zener Regulators	4
4.0	Unit Requirements	4
4.1	Use	4
4.2	Specifications	4
4.3	Compliance Capability	5
5.0	Test Equipment Required	6
5.1	Standard Commercial Test Equipment and Description	6
5.2	Special Test Equipment	10
6.0	Material and Finishes	12
7.0	Block Diagram; Filter Coupler	13
7.1	Schematic, OP AMP	14
7.2	Block Diagram, Calibration layout	15
8.0	Typical Performance Curves	16
8.1	Component Notes	22
9.0	Repairable/Replaceable Components	26
9.1	Repairable Components	26
9.2	Replaceable Components	27
10.0	Preventative Maintenance/Calibration	29
10.1	Safety Precaution	31

Filter/Coupler

1.0 Purpose:

The purpose of this engineering design data and description is to provide the essential information needed to permit an evaluation of the design of the RF Filter-Coupler-Peak Amplifier, Bird Electronic Model 3316, as it relates to the requirements of GD/E Al6235, Detecting Element, Direction Coupler.

2.0 Scope:

This report includes a block diagram of the unit, with a functional description of each subassembly, including a circuit schematic of the printed circuit board for the peak-reading operational amplifier. Also included in the report is a description of the capabilities of the unit relative to the design requirements.

Finally, a list of test equipment required for the adjustment, calibration, and servicing of the unit is included.

3.0 Functional Description:

3.1 Low-Pass Filter:

The low-pass filter is used to remove the second, third, and higher harmonic components of the TACAN output waveform before the signal is sensed by the directional coupler. Depending upon the phase and amplitude of the harmonics, the peak value of the output signal can be considerably greater or less than that of the fundamental waveform, causing errors in measuring the peak power of the TACAN output. The filter is mechanically integral with the detecting element and appears at the input port of the instrument. It consists of short sections of coaxial transmission line with various impedances which act as semi-lumped elements.

3.2 Line Section:

The line section is a 50-ohm impedance, rigid, coaxial transmission line with air dielectric except for compensated teflon beads at each end to support the center conductor. Its main mechanical function is to provide a mechanically and electrically stable support for the directional coupler circuit. The line section is encased in a housing which also contains the directional coupler and printed circuit board, and acts as an EMI shield for the entire circuit.

3.3 Coupler:

A directional coupler circuit is incorporated into the detecting element which senses the forward traveling power wave. The power waves traveling through the RF line section produce energy in the coupling circuit by the combination of inductance and capacitance. The directivity of the coupler is dependent upon orientation and the balance of circuit values. The coupler circuit is mounted so that the coupling loop extends inside the RF line section. The component values of the coupler circuit must be carefully chosen so as to provide maximum response to narrow pulse widths of the TACAN waveform. The output of the coupler circuit is a rectified voltage which is a function of the directional power envelope. This voltage is applied to the input of the peak-reading operational amplifier.

3.4 Peak-Reading Operational Amplifier:

The peak-reading operational amplifier consists of several stages of amplification, using integrated circuits and transistors. The amplifier section of the instrument is assembled on the printed circuit board, along with the voltage regulating circuit.

The first stage of the operational amplifier consists of an I.C.

(integrated circuit) differential amplifier, followed by a series diode and a charging capacitor. The diode and capacitor form a peak-reading voltmeter, the power for which comes from the I.C. amplifier. The series diode is specially chosen for its high conductance and extremely low leakage. When measuring peak voltages at narrow pulse widths and low repetition rates, leakage current will degrade the measurement, especially at high ambient temperature conditions. Temperature compensation of the detecting element is achieved by duplicating the susceptible coupler components at the differential input to the I.C. amplifier. The high gain and high speed of this amplifier provides the capability of the instrument to respond to short pulse lengths. An adjustable center tap between the differential inputs of the amplifier allows compensation for minor offset errors.

The charging capacitor is followed by a two stage current amplifier of extremely high gain. The purpose of this stage is to present a very high load resistance to the charging capacitor, thereby providing a long discharge time constant. This enables the instrument to work at low repetition pulse rates.

The final stage of the amplifier channel is another I.C. differential amplifier. This stage provides the voltage gain necessary to drive the readout device. Since the first two stages have a closed loop gain of unity, the final stage amplifies the full-scale coupler output signal from about 150 millivolts to 5 volts, the requirement of the digital readout. Feed-back to the differential input of this amplifier is variable and provides the adjustment necessary to calibrate the instrument.

3.5 RFI Filters and Zener Regulators:

In order to reduce the possible susceptibility of the detector element to EMI, feed-thru RFI filters are incorporated as the DC connectors for the power supply leads and for the signal output leads. Susceptibility to conducted RFI in the signal output lead is possible due to the feed-back of the high gain amplifier output stage.

The RFI filters in the +15V and -15V power supply leads reduce the possibility of RFI getting into the input stage of the amplifier channels. They also reduce the possibility of RFI emanating from the detector element from being conducted through the power supply lines.

Zener regulators on the power supply lines remove any low frequency interference that might be conducted on the power supply lines.

4.0 Unit Requirements:

4.1 Use:

The Detecting Element, Directional Coupler, is a subassembly of the Micro TACAN Test Set. The Detecting Element incorporates a directional coupler to sense the forward traveling power wave. It is used to measure the output of the TACAN transmitter.

4.2 Specifications:

The major electrical considerations as specified by GD/E Dwg. A16235 are tabulated below:

1. Frequency band: 962 MHz to 1213 MHz.
2. Input wave form: Gaussian shaped pulses
Width between 50% amplitude points: 3.5 ± 0.5 us.
Rise and fall times between 10% and 90% amplitude points:
 2.5 ± 0.5 us.

Pulse repetition frequency: 24 pps min.

3. Power range: 5000 W peak forward power.
4. Output signal: 0 to 5v DC into 10 K Ω min. for full scale.
5. Insertion loss: 0.3 dB max. into 50 Ω line.
6. Insertion VSWR: 1.4/1 max. into 50 Ω line.
7. L.P. Filter attenuation: 30 dB min. 1920 MHz to 3650 MHz.
8. Accuracy: The coupler, together with its display shall meet the accuracies specified in the following table, over the temperature range of -10°C to +85°C and the frequency range of 1025 MHz to 1150 MHz.

Scale	Range	Range Accuracy
5 kW Fwd.	0.4 to 0.7 kW	±1.7 dB
	0.7 to 1.0 kW	±1.2 dB
	1.0 to 1.5 kW	±0.8 dB
	1.5 to 4.0 kW	±0.6 dB
	4.0 to 5.0 kW	±0.8 dB

9. DC power input: +15V DC ±3% @ 25 ma.
-15V DC ±3% @ 35 ma.
10. Overload capability:
 - 20 W max. average power, C.W.
 - 5 kW max. peak power, pulsed.

4.3 Compliace Capability:

The Bird Electronic Model 3316, Filter-Coupler-Peak Amplifier, complies with the specifications set forth in the GD/E Dwg. A16235, for Detecting Element, Directional Coupler.

5.0 Test Equipment Required:

5.1 Standard Commercial Test Equipment and Description

Substitution of equivalent test equipment may be made if listed equipment is not available. If equipment is to be substituted, the equipment must be equal to or greater than the following. Test equipment calibration requirements should comply with MIL-C-45662A.

5.1.1 Hewlett-Packard Model 612A

Frequency Range: 450 to 1230 MHz
Frequency Accuracy: $\pm 1\%$
Voltage Output: 0.5v. to 0.1 μV (+7 to -127 dBm)
Attenuator Accuracy: ± 1 dB, 0 to -127 dBm
Output Impedance: 1.2/1 VSWR max. into 50 Ω
Calibration Interval: Once Yearly

5.1.2 Alford 2181-3 Slotted Line

Frequency Range: 200 to 4000 MHz
Impedance Error: Less than 0.5% of 50 Ω
Residual VSWR: Less than 1.010/1
Calibration Interval: 3 Years

5.1.3 FXR Model B200A Detector Probe

Frequency Range: 1,000 to 12,400 MHz
Output: Crystal Detector
Calibration Interval: - Not applicable

5.1.4 Hewlett-Packard Model 415B VSWR Indicator

Center Frequency: 1000 Hz $\pm 2\%$
Sensitivity: 0.1 μV at 200 Ω position
Attenuator Range: 70 dB
Attenuator Accuracy: ± 0.1 dB/10 dB
 ± 0.2 dB cumulative
Input Impedance: 200 Ω Crystal
Calibration Interval: 6 Months

5.1.5 AIL Type 125 Power Oscillator

Frequency Range: .2 to 3.0 Ghz
Frequency Accuracy: $\pm 1\%$
Power Output: 50 μW . to 25 W
(0.9 to 1.8 Ghz)
Output Impedance: 50 Ω nominal
Calibration Interval: Not applicable

5.1.6 Hewlett-Packard Model 616A

Frequency Range: 1800 to 4000 MHz
Frequency Accuracy: $\pm 1\%$

Voltage Output: .223v. to 0.1 uV (0 to -127 dBm)
Attenuation Accuracy: ± 1.5 dB, -7 dBm to -127 dBm
Output Impedance: 1.8/1 VSWR max. into 50 Ω
Calibration Interval: Once Yearly

5.1.7 Polarad R-B1 Receiver, with RS-T Tuning Head

Frequency Range: 1900 to 4340 MHz
Frequency Accuracy: $\pm 1\%$
Sensitivity: 0.1v. (RMS) max. RF input level
-80 dBm min. RF sensitivity
Meter Accuracy: ± 2 dB on 70 dB scale
 ± 1 dB on 30 dB scale
Calibration Interval: Once Yearly

5.1.8 Weinschel Model 50, 10 dB Pad (2 Req'd)

Frequency Range: DC to 3 GHz
Attenuation Frequency Sensitivity: ± 0.2 dB max.
Impedance: 1.15/1 VSWR max., DC to 1 Ghz
1.2/1 VSWR max., 1 GHz to 3 Ghz
Calibration Interval: Once Yearly

5.1.9 Bird Model 43 THRULINE Wattmeter (2 req'd)

Power Rating: 1 W to 5 kW (Depends on plug-in Element)
Insertion VSWR: 1.05/1 max.
Accuracy: $\pm 5\%$ of full scale.

5.1.10 Bird No. 25J Plug-In Element (2 req'd)

Frequency band: 950 to 1260 MHz
Power range: 25 W.
Accuracy: (See 5.1.9)
Calibration interval: 6 months

5.1.11 Bird No. 1J Plug-In Element

Frequency band: 950 to 1260 MHz
Power range: 1 W.
Accuracy: (See 5.1.9)
Calibration interval: 6 months

5.1.12 Applied Microwave Lab., Model PH20K (Modified)

Pulsed RF Generator

Frequency Range: 950-1220 MHz
Power Output: 15 kW max., at 1 GHz
(at .001 Duty) 12 kW max., at 2 GHz
10 kW max., at 3 GHz
Voltage Output: -8 kV max., pulse
Pulse Rate: 24 pps to 700 pps.
Pulse Width: 0.3 to 6 us.
0.1 to 0.3 us.
3 to 25 us.
Pulse Rise Time: 0.1 us max.
Calibration Interval: Once Yearly

5.1.13 Bird Model 5197 L.P. Filter

Frequency Range: 960 to 1600 MHz pass band
2000 to 8200 MHz., 60 dB
8200 to 10,000 MHz., 40 dB
Impedance: 1.5/1 VSWR max., pass band
Insertion Loss: 0.4 dB max., pass band
Calibration Interval: Not applicable

5.1.14 Hewlett-Packard Model 3430A DC Digital VM

Voltage Range: 100.0 mV to 1000v. F.S. (5 ranges)
Voltage Accuracy: $\pm(0.1\%$ of reading +1 digit)
Calibration Interval: 6 Months

5.1.15 Coupler Load Resistor

10K ohms, $\pm 5\%$ 1/2 watt

5.1.16 Narda Model 3042-30 Coupler

Frequency Range: .950 to 2.0 GHz
Directivity: 20 dB min.
Coupling: 30 dB
Accuracy: ± 0.1 dB (calibrated)
VSWR: 1.1/1 max.
Calibration Interval: Once Yearly

5.1.17 Alfred Model 1001 Crystal Detector

Frequency Range: 10 MHz to 12.4 GHz
Frequency Response: ± 0.5 dB
Sensitivity (No Load): Less than 0.4 mW
Input Power for 0.1v. Rectified Output
Max. Input Power: 10 mW
VSWR: Less than 1.4/1 to 10 GHz
Calibration Interval: Not applicable

5.1.18 Coaxial Connector, Tee-Adapter

UG-107B/U

5.1.19 Bird Model 8011 Load Resistor

Frequency Range: DC to 4000 MHz
Power Rating: 2 watts, 50 μ
VSWR: 1.04 max., DC to 1000 MHz
1.06 max., 1000 to 2000 MHz
1.1 max., 2000 to 4000 MHz

5.1.20 Tektronix 547 Oscilloscope

Sweep Rate: 0.1 usec/cm to 5 sec/cm
Sweep Rate Accuracy: $\pm 2\%$
Sweep Manification: 2X, 5X, 10X, $\pm 5\%$
Calibration Interval: 6 Months

5.1.21 Tektronix Type 1A1 Plug-In Unit

Deflection Factor: 50 mv/cm to 20v/cm
Band-Pass: DC to 50 MHz
Risetime: 7 nsec
Calibration Interval: 6 Months

5.2 Special Test Equipment:

5.2.1 Bird Model 8080 Termlaine Load

Power Rating: 25 W con't duty
VSWR: Load must be selected to 1.1 max. VSWR
over frequency band of 962 MHz to 1213 MHz
Input Connector: Type N-Female
Calibration Interval: Once Yearly

5.2.2 Bird Model 4314 Test Set, RF Power (Modified)

Frequency Range: 0.45 to 2300 MHz
Power Range:
Avg. (CW) Mode: 1 W to 10kW
Peak-Pulse Mode: 1 W to 10 kW
Square Pulse Parameters:
Min. Repetition Rate: 10 pps.
Min. Pulse Width: 0.4 us, 100-2300 MHz
Accuracy (Pulse Mode): ±3% (calibrated)
Calibration Interval: 3 Months

5.2.3 Bird No. 10000J Plug-In Element

Frequency Band: 950 to 1260 MHz
Power Range: 10 kW peak power
Accuracy: (see above)
Calibration Interval: 3 Months

5.2.4 Bird Model No. 5000J Plug-In Element

Frequency Band: 950 to 1260 MHz
Power Range: 5 kW peak power
Accuracy: (see above)
Calibration Interval: 3 Months

5.2.5 Bird No. 2500J Plug-In Element

Frequency Band: 950 to 1260 MHz
Power Range: 2.5 kW peak power
Accuracy: (see above)
Calibration Interval: 3 Months

5.2.6 Bird No. 1000J Plug-In Element

Frequency Band: 950 to 1260 MHz
Power Range: 1 kW peak power
Accuracy: (see above)
Calibration Interval: 3 Months

5.2.7 OS Model 21040 Adapter (2)

Mates N Jack and OSM Female Connectors

5.2.8 DC Power Supply, Regulated (In-House Unit):

+15V DC±3% @ 25 ma. max.
-15V DC ±3% @ 25 ma. max.

5.2.9 Test Cover:

Modified cover P/N 3316-006, with access holes
for adjusting offset and calibration controls.

6.0 Materials and Finshes:

6.1 Materials Used:

The various components of the Model 3316 unit have the following material used as the basic construction material:

1. Low Pass Filter: Brass body with brass flanges, silver plated.
2. Line Section and Housing: Brass, silver plated.
3. Cover: Brass, silver plated.
4. Connector, OSM: -

Body: Stainless steel, gold plated.

5. Screws: All screws are stainless steel, with stainless steel lock washers and flat washers.

6.2 Finishes:

Except for the connectors, the entire unit is finished with navy gray enamel per MIL-E-15090, with washcoat primer.

7.0 Block Diagram:

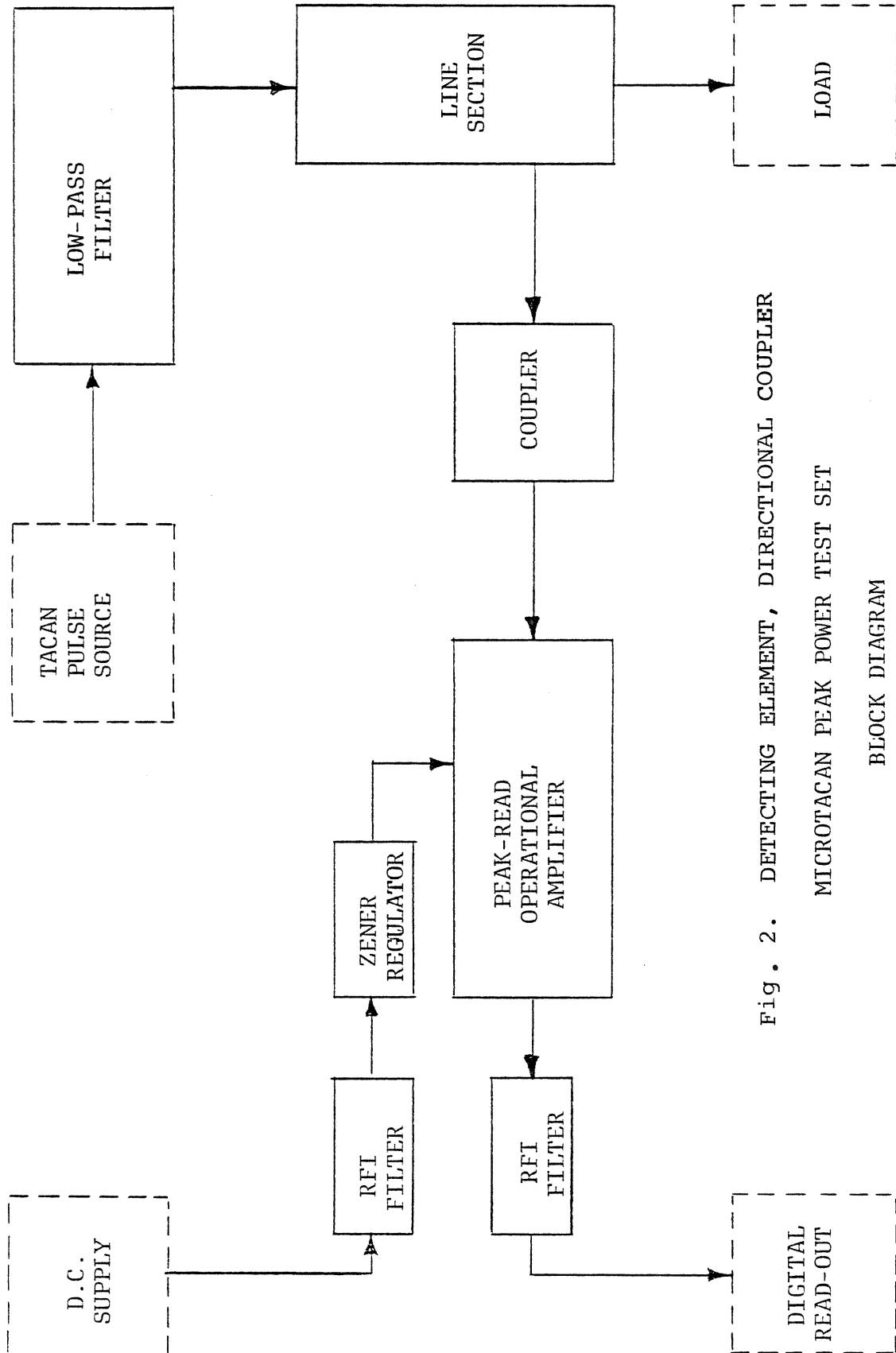

Fig. 2. DETECTING ELEMENT, DIRECTIONAL COUPLER
MICROTACAN PEAK POWER TEST SET
BLOCK DIAGRAM

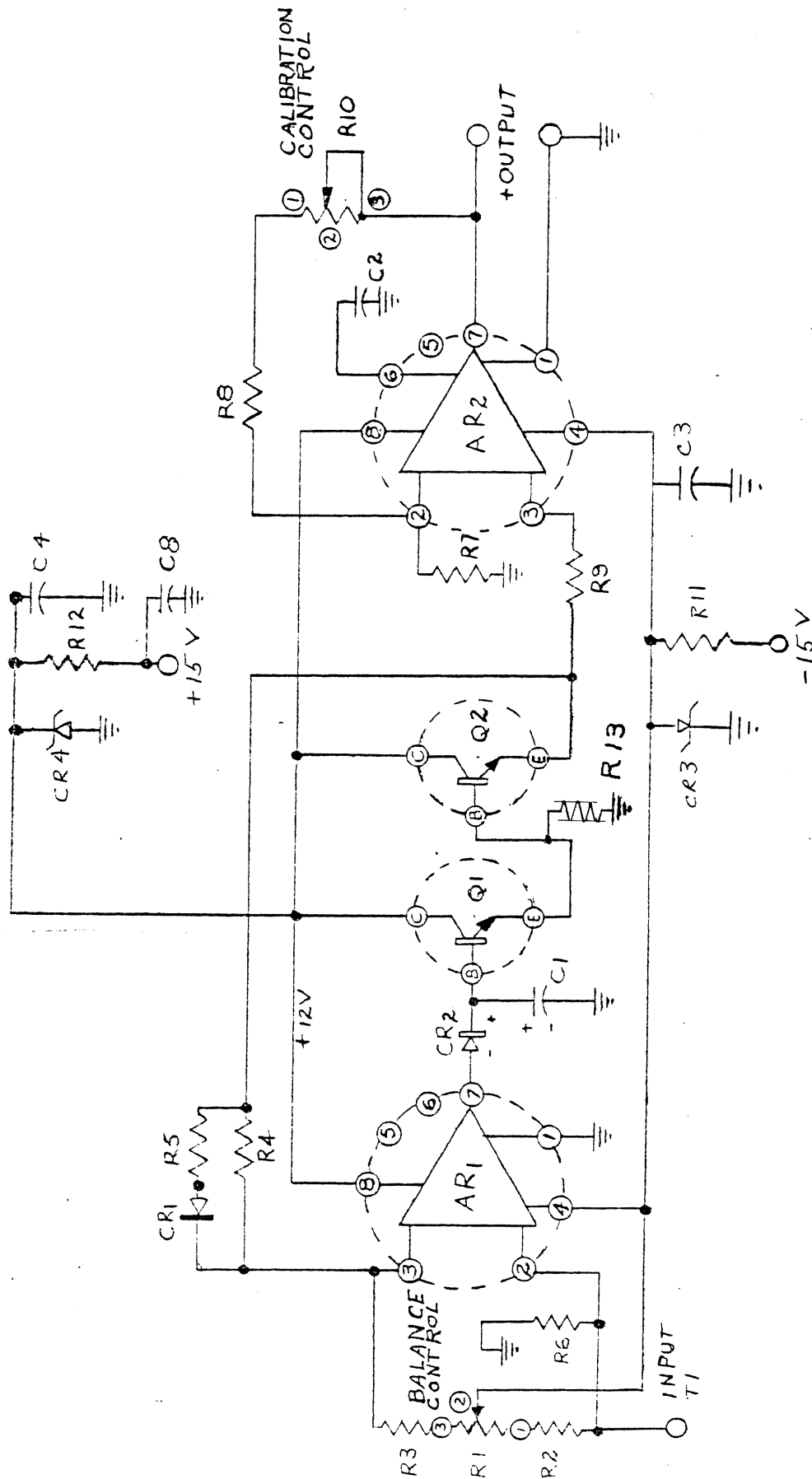

Fig. 3: PEAK READING
OPERATIONAL AMPLIFIER SCHEMATIC

COUPLER FREQUENCY SENSITIVITY, CALIBRATION AND SCALE SHAPE.

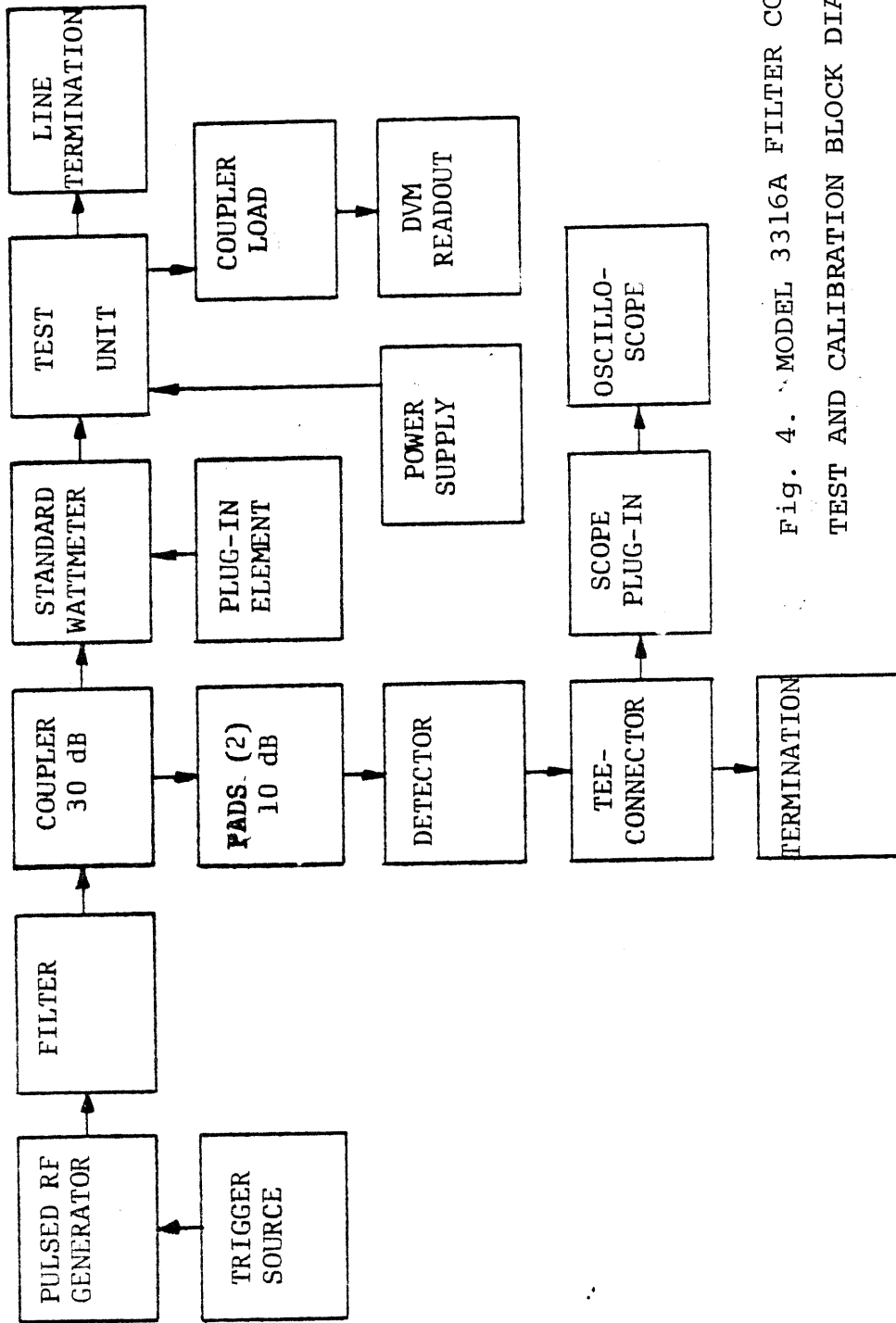

Fig. 4. MODEL 3316A FILTER COUPLER.
TEST AND CALIBRATION BLOCK DIAGRAM

7.2 Block Diagram

8.0 Performance Curves

INSERTION VSWR
MODEL 3310 FILTER-COUPLER-PEAK AMP.
UNIT: FIRST, W/LINE EXPENSION
DATE: 9/12/68 P.T.

MAXIMUM
LIMIT

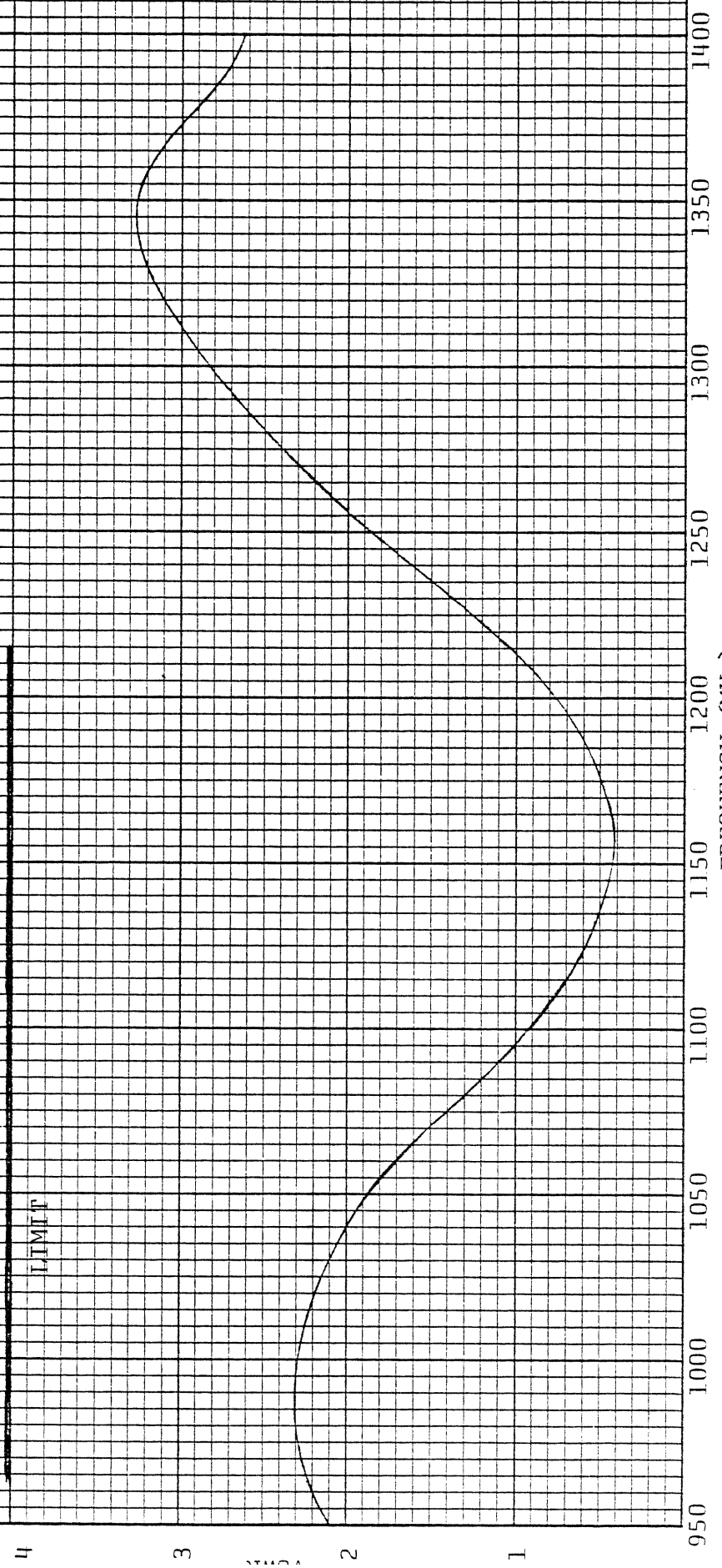

STOP-BAND ATTENUATION
MODEL 3B10 FILTER-COUPLED-PIK AMPLIFIER
UNIT: JRSST
DATE: 8/9/58 S.A.M.

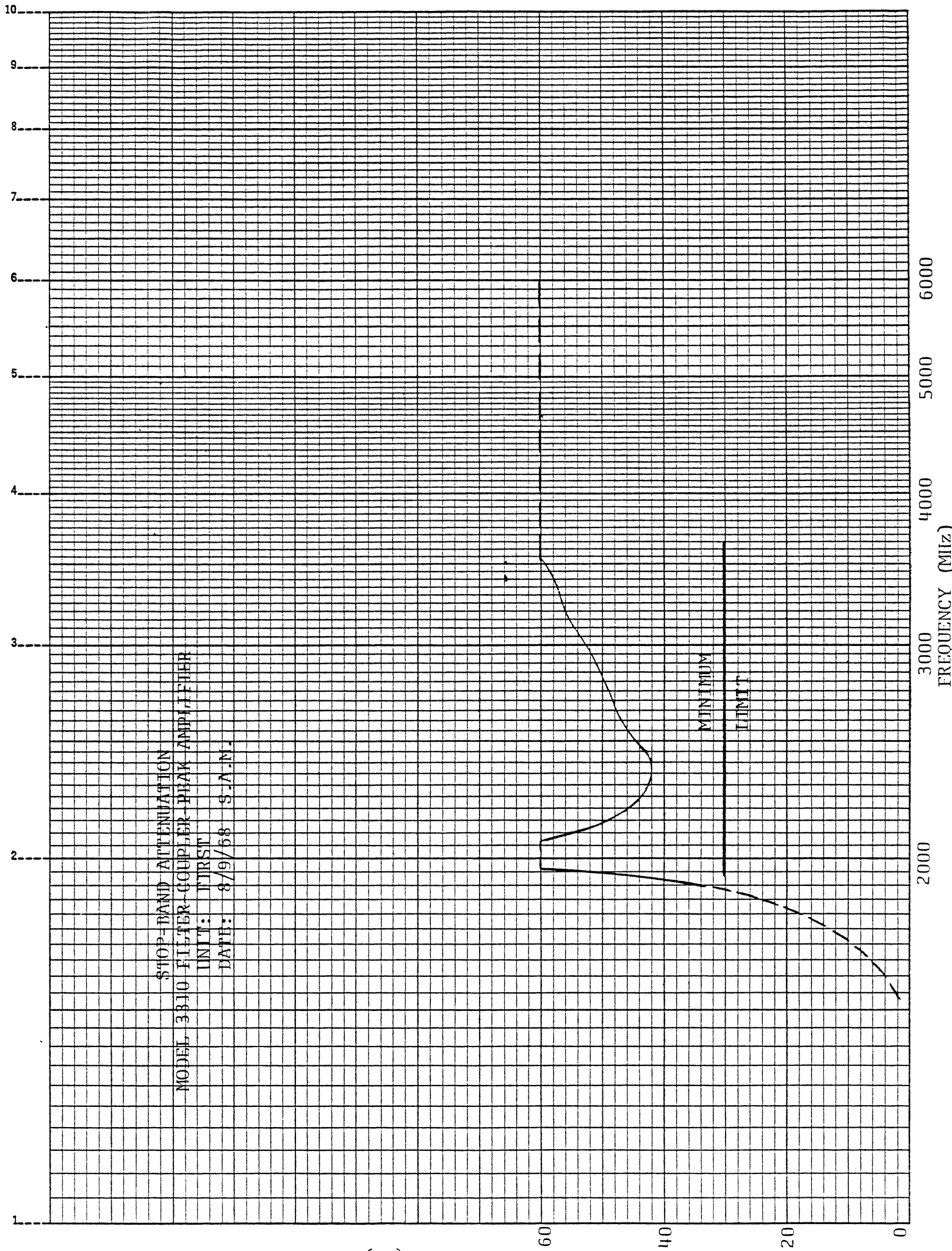

FREQUENCY RESPONSE
MODEL 3316 FILTER-COUPLER-PEAK AMPLIFIER

UNIT: NO. 8
DATE: 2/6/70
PULSE CONDITIONS:
3.0μs PULSE WIDTH
24pps PULSE REP. RATE

45.0
4.0

UPPER LIMIT

AMB. TEMP.

-10°C

+85°C

LOWER LIMIT

4.0

1020

1040

1060

1080

1100

1120

1140

1160

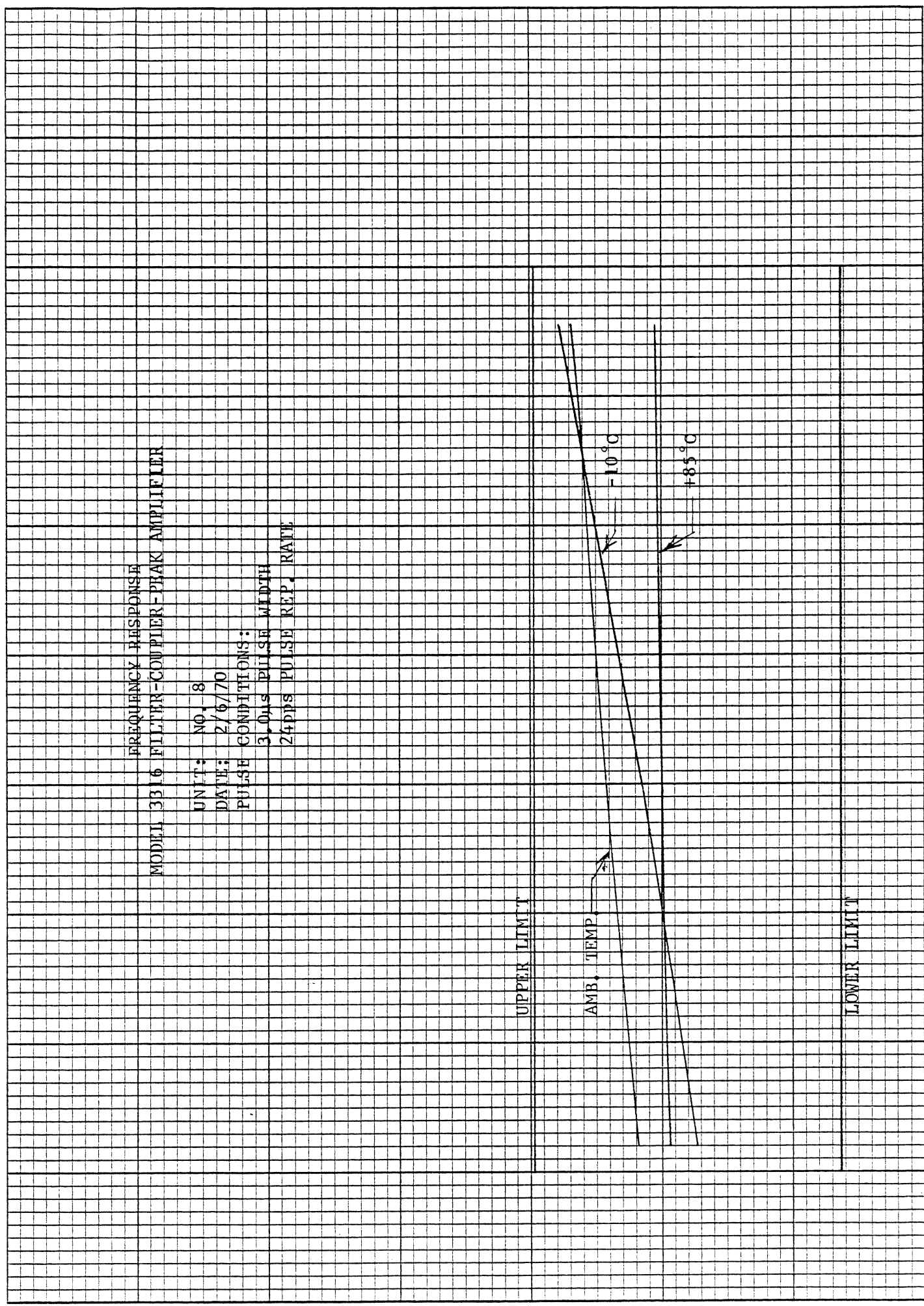

SCALE SHAPE
 MODEL 3316 FILTER-COUPLED-PEAK-AMPLIFIER

UNIT: NO. 8
 DATE 2/6/70
 TEMPERATURE: AMBIENT
 PULSE REP. RATE: 24pps

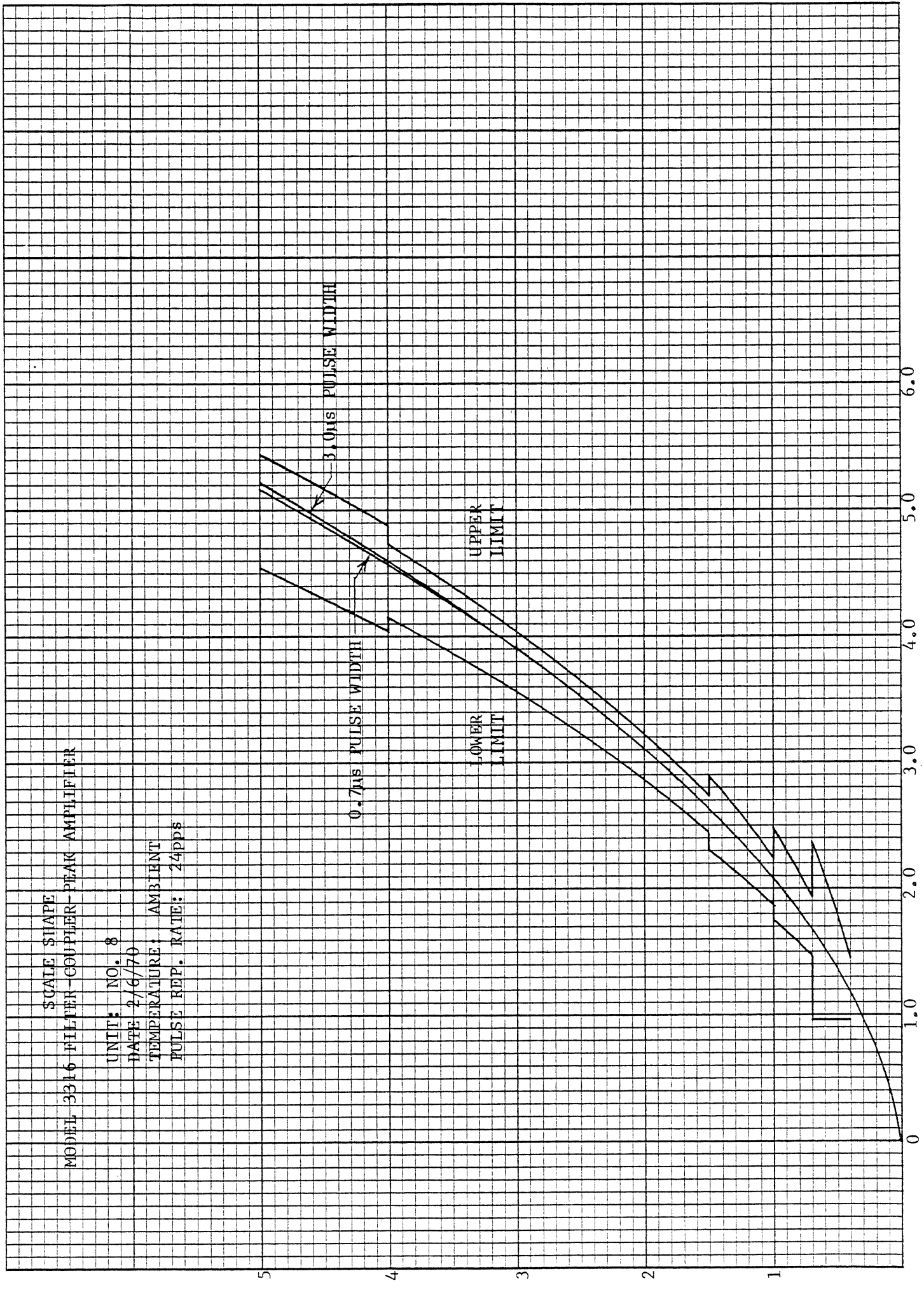

TEMPERATURE DEVIATION
MODEL 3316 FILTER-COUPLER-PEAK AMPLIFIER

UNIT: NO. 8
DATE: 2/6/70
TEMPERATURE: $\pm 85^{\circ}\text{C}$
PULSE REP. RATE: 24pps

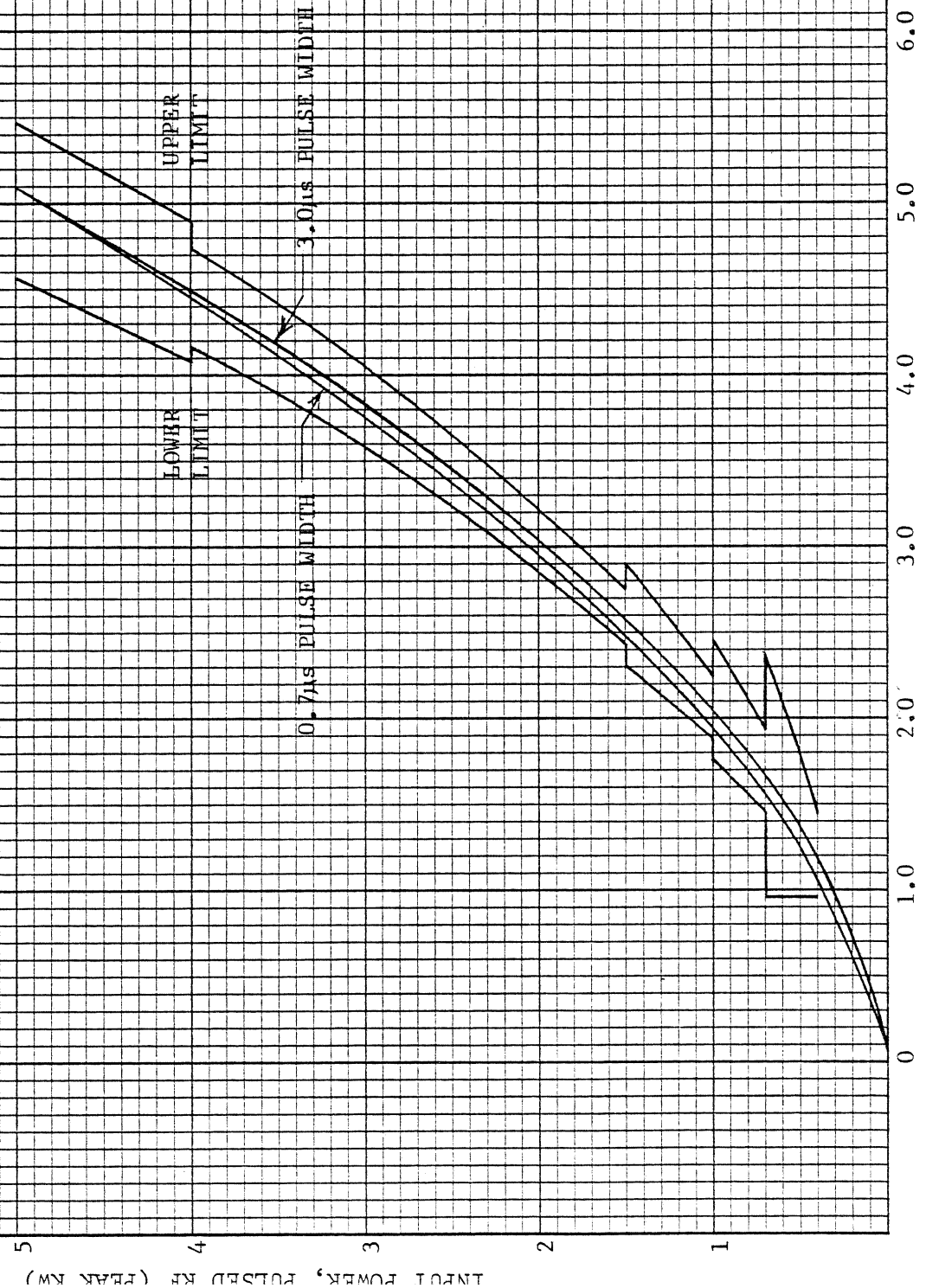

TEMPERATURE DEVIATION
MODEL 3316 FILTER-COUPPLER-PEAK AMPLIFIER

UNIT: NO. 8
DATE: 2/7/70
TEMPERATURE: -10 °C
PULSE REP. RATE: 24pps

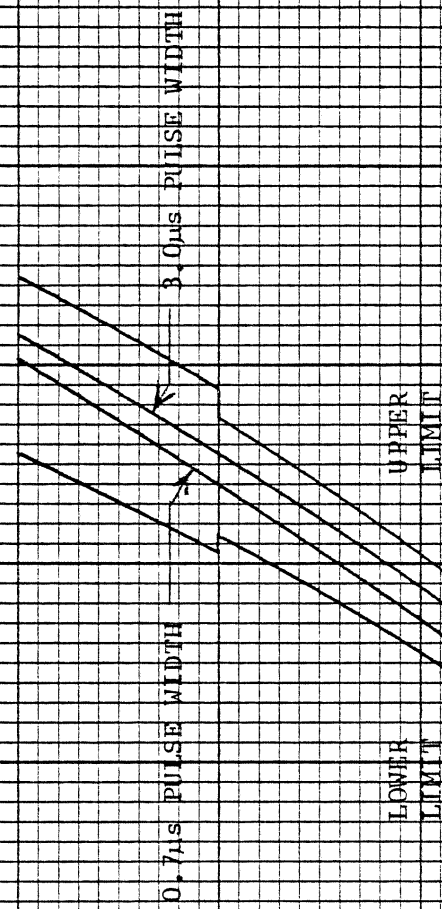

INPUT POWER, PULSED RF (PEAK KW)

PULSE WIDTH

UPPER LIMIT

LOWER LIMIT

0.7 μs PULSE WIDTH

3.0 μs PULSE WIDTH

8.1 Component Notes:

(Amplifier Circuit)

1. Resistors P/N 5-724 are Bourns Type 3300 W wirewound potentiometers. These variable resistors meet the requirements of MIL-R-27208A. The stress ratio in use is much less than 0.1. The values from Fig. 7.5.14B of MIL-HDBK-217A were used as the nearest part type.

2. Resistors P/N 5-521 are IRC Type CEA T-0 1/8, MIL-Type RN55 (D). The stress ratio in use is much less than 0.1. The values from Fig. 7.5.10 B of MIL-HDBK-217A for MIL-R-10509, characteristic D, were used.

3. Resistor P/N 5-760 is an IRC Type CCA T-0 1/4 W., MIL-Type RN60D. The stress ratio is less than 0.1. The values from Fig. 7.5.10B of MIL-HDBK-217A for MIL-R-10509, characteristic D, was used.

4. Polarized solid tantalum capacitors P/N 5-525 are Sprague Electric Type CS13-BF105K. The values from Fig. 7.6.32B of MIL-HDBK-217A for MIL-C-26655B were used. The stress ratio in use is less than 0.1.

5. Diode P/N 5-761 is Fairchild Semiconductor Type USN 1N3595. This diode meets the requirements of MIL-S-19500/241. Application K-factor was taken from Fig. 7.4.3B of MIL-HDBK-217A for MIL-S-19500 silicon diodes.

6. Diode P/N 5-651 is Hewlett-Packard Type 5082-2800 microwave detector. The values from Fig. 7.4.7B of MIL-HDBK-217A for MIL-S-19500 were used. The stress factor in use is less than 0.2.

7. Transistor P/N 5-679 is Fairchild Semiconductor Type 2N2484, NPN silicon. The values from Fig. 7.4.4B of MIL-HDBK-217A for MIL-S-19500 were used as the nearest part type.

8. Amplifier P/N 5-705 is Fairchild Semiconductor Type uA710 integrated circuit of NPN silicon. No failure rate is available for this circuit. The values from Fig. 7.4.4B of MIL-HDBK-217A for MIL-S-19500 were used as the nearest part type.

9 Amplifier P/N 5-706 is Fairchild Semiconductor Type uA712 integrated circuit of NPN silicon. No failure rate is available for this circuit. The values from Fig. 7.4.4B of MIL-HDBK-217A for MIL-S-19500 were used as the nearest part type.

10. One amplifier circuit is used in each detecting element unit.

(Coupler Circuit)

11. Resistor P/N 5-546 is Allen Bradley Type CB Composition carbon. As there is no established failure rate for this resistor, the values of Fig. 7.5.3B of MIL-HDBK-217A for MIL-R-11 were used as the nearest part class. The stress ratio is much less than 0.1.

12. Resistor P/N 5-157 is IRC Type CEA T-0 1/8, MIL-Type RN55 (D). The values from Fig. 7.5.10B of MIL-HDBK-217A for MIL-R-10509, characteristic D, were used. The stress ratio in use is much less than 0.1.

13. Capacitors P/N 5331 and P/N 5332 are Erie Type 2930-000 button mica. The values of Fig. 7.6.20B of MIL-HDBK-217A for MIL-C-10950 were used as the nearest part type. The stress ratio in use is much less than 0.1.

14. Capacitor P/N 5-560 is Erie Type 8013 molded ceramic with leads. The values from Fig. 7.6.8B of MIL-HDBK-217A for MIL-C-20 were used. The stress ratio in use is much less than 0.1.

15. Diode P/N 5-651 is Hewlett-Packard Type 5082-2800 microwave detector. The values from Fig. 7.4.7B of MIL-HDBK-217A for MIL-S-19500 were used. The stress factor in use is less than 0.2.

16. One coupler circuit is used in each detecting element unit.

17. Resistor P/N 5-589 is IRC Type GBT-1/2 composition carbon. The values of Fig. 7.5.3B of MIL-HDBK-217A for MIL-R-11 were used. The stress ratio in use is approximately 0.3.

18. Resistor P/N 5-537 is IRC Type GBT-1 composition carbon.
(Replaced by P/N 5-589)

19. Capacitor P/N 5-525 is Sprague Type CS13-BE106K polarized solid tantalum. The values of Fig. 7.6.32B of MIL-HDBK-217A for MIL-C-26655B were used. The stress ratio used was 0.8.

20. RFI filter P/N 5-729 is Allen-Bradley Type SMFB-A4 feed-thru. No failure rates are established for these parts. Since they are effectively a by-pass ceramic capacitor, the values of Fig. 7.6.23B of MIL-HDBK-217A for MIL-C-11015 were used as the nearest part class. The stress ratio in use is less than 0.1.

21. Zener diode P/N 5-685 is Motorola USN-1N752A. The values from Fig. 7.4.3B of MIL-HDBK-217A for MIL-S-19500/127 was used. The normalized junction temperature was taken as 0.4.

22. Connector P/N 3316-011 is AMP No. 582381 general purpose connector for printed wiring boards with four active pins. As no failure rate is available, the values from Fig. 7.9.5B and 7.9.6B of MIL-HDBK-217A for MIL-C-21097 were used. Mating was estimated to be once every 1200 hours.

23. Capacitor P/N 5-525 is a Sprague Electric Type CS13-BF105K, solid tantalum construction. The values from Fig. 7.6.32B of MIL-HDBK-217A were used. The stress ratio used was 0.8.

24. A single RFI filter and regulator circuit is used in each detecting element unit.

25. RF connectors P/N 3316-044 and P/N 3316-042 are SMA Type miniature screw-on coaxial connectors. This connector has no established failure rate, so the value from Figs. 7.9.8 and 7.9.9 of MIL-HDBK-127A were used, based on the assumption of one mating per 1200 hours use.

26. This sub-assembly interconnection between the L.P. filter and the line section is a static RF coaxial connector. The values of Figs. 7.9.8 and 7.9.9 of MIL-HDKB-217A were used. Only the static failure rate was used as this is considered a permanent connection.

27. Only one set of connectors are used in each detecting unit.

9.0 Repairable/Replaceable Components:

9.1 Repairable Components:

L.P. Filter Assembly, P/N 3316-041

The L.P. Filter assembly consists of filter sub-assembly P/N 3316-041 and SMA type RF connector P/N 3316-042. The filter assembly is not repairable except by replacement of the complete assembly. The SMA connector is replaceable.

Line Section Assembly, P/N 3316-040

The line section is not repairable except by replacement of the complete assembly.

Element Plate Assembly, (Coupler Circuit), P/N 3316-012

The element plate assembly is not field repairable, due to the involved nature of obtaining sensitivity and directivity of the coupler circuit. In the event of failure of the coupler, the integral package of balanced element plate assembly and line section should be replaced.

Printed Circuit Board Ass'y, P/N 3316-003

The circuit board assembly can be repaired by replacing individual components, or by replacing the entire assembly. Most components can be replaced directly with only minor adjustments for zero shift and calibration. The transistors and integrated circuits are plug-in and can easily be replaced.

Cover Assembly, P/N 3316-006

The extent of repairing the cover assembly is to replace the PC board connector, P/N 3316-011, or the complete cover assembly. The RFI filter feed-thru's are best repaired by replacing the cover assembly.

RF Connector Assemblies, P/N 3316-042 and P/N 3316-044

The input and output RF connectors are SMA type, straight and right angle female connectors. These connectors are not repairable, and in case of failure, should be replaced with their respective assembly types. The straight SMA, filter input connector (J1), is P/N 3316-042. The right angle SMA, line section output connector (J2), is P/N 3316-044, and consists of the right angle connector and the silver-plated mounting flange. The connector is not removable from this flange. In replacing these units, care must be taken to prevent twisting the center conductor. The use of replaced connectors is questionable.

9.2 Replaceable Components:

	L.P. Filter:	
	P/N 3316-041	Ass'y, Filter
	Line Section:	
	P/N 3316-040	Ass'y Line Section
	Coupler Circuit:	
	P/N 3316-012	Ass'y, Element Plate
	Circuit Board:	
	P/N 3316-003	Ass'y, PC Board
R1 & R10	5-724	Potentiometer, 5 K Ω
R2 & R3	5-521-8	Resistor, 78.7 K Ω
R4 & R6	5-521-4	Resistor, 4990 Ω
R5	5-157	Resistor, 20 K Ω
R7 & R9	5-521-7	Resistor, 499 Ω
R8	5-521-9	Resistor, 17.8 K Ω
R13	5-760-1	Resistor, 1 mega Ω
R11 & R12	5-589-3	Resistor, 270 Ω

C1 & C8	5-525-1	Capacitor, 1 mfd
C2	5-525-2	Capacitor, 0.1 mfd
C3 & C4	5-522-1	Capacitor, 10 mfd
AR1	4311-050-2	Amplifier, Diff., uA710
AR2	4163-074	Amplifier, Diff., uA712
Q1 & Q2	4311-056-2	Amplifier, 2N2484
CR1	5-651	Diode, HP-2800
CR2	5-761	Diode, USN 1N3595
CR3	5-685-1	Diode, Zener
CR4	5-685-2	Diode, Zener

Cover:

P/N	3316-006	Assy, Cover
	3316-011	Assy, Conn., PC Board
	3316-017	Gasket, RFI

RF Connectors:

P/N	3316-042	Ass'y, Conn., Female SMA
	3316-044	Ass'y, Conn., Female SMA Right Angle

10.0 Preventive Maintenance:

Preventive maintenance for this unit is limited to a semi-annual calibration check. If recalibration is necessary, the procedure consists of the following steps:

1. Adjust the "Zero Shift" potentiometer. (R1)
2. Adjust the amplifier sensitivity for the proper output at the 80% of full scale power level. (R2)
3. Check the response over the frequency range and the output scale shape.

If desired, a VSWR check can be performed in conjunction with the calibration check. With normal usage, there should be no change in the VSWR of the unit. However, extreme mishandling of the unit could result in a change in the VSWR.

An excessively high VSWR might also affect the calibration of the coupler output. Therefore, a VSWR check of the system should be made before the calibration check.

Limited Life Components:

There are no components used in this unit which are considered to have limited life or that should be replaced before their catastrophic failure due to environmental stress rather than time.

Support Equipment

The following equipment or its equivalent will be necessary to make VSWR measurements or calibration checks on the detecting element. The equipment should bear current calibration identification.

VSWR Measurement:

Signal Generator:

Hewlett-Packard 612A, 450-1230 MHz.

Slotted line and probe:

Alford 2181-3 Slotted line, 200-4000 MHz

FXR Model B200A Detector probe.

Indicator, VSWR

Hewlett-Packard Model 415B VSWR Indicator.

Line Termination:

Bird Model 8080 TERMALINE Load.

Load must be selected to 1.1 max. VSWR over
frequency band of 962 MHz to 1213 MHz.

Coupler Calibration:

Pulsed RF Generator:

Applied Microwave Lab., Model PH20K

950-1220 MHz., 15 kW peak power.

RF Filter:

Bird Model 5197 L.P. Filter, 1600 MHz.

Calibration Standard:

Bird Model 4313 Test Set, RF Power (Modified)

Special calibration.

DC Power Supply:

Dual power supply, regulated +15V, -15V, 25 ma.

Coupler Readout:

Hewlett-Packard, Model 3430A

Digital Voltmeter, 0-10v range.

Coupler load resistor

10 k ohms, $\pm 5\%$, 1/2 W.

Calibration Cover:

Special coupler-amplifier cover with access holes for "Zero-Shift and "Sensitivity" adjustments.

10.1 Safety Precautions:

There are no special safety hazards inherent in the directional coupler unit. The safety precautions to be followed should be the same as associated with the primary equipment with which the unit is to be used. The unit should not be connected nor disconnected in the transmission line while RF power is being applied because of the high voltages possible with an open circuit. Also, since the unit might operate in a hazardous area, the DC supply and output cable should not be connected or disconnected while the DC voltage is applied, to prevent any possibility of sparking, although the voltage and current are very low.