INSTRUCTION BOOK

**THRULINE[®] RF POWER METER MODEL 4421
AND
THRULINE[®] DIRECTIONAL RF POWER SENSORS
4020 SERIES, 4027A SERIES,
4027F SERIES, AND 4028 SERIES**



**Electronic Corporation
Cleveland (Solon) Ohio USA**

Bird[®] Electronic Corporation
30303 Aurora Road
Cleveland (Solon), Ohio 44139

Sales & Technical Support: 440-248-1200
866-695-4569 toll free
Sales email: sales@bird-technologies.com
Technical Support email: techsupport@bird-technologies.com

©Copyright 2006 by Bird Electronic Corporation
Instruction Book Part Number 920-4421 Rev R
ThruLine[®] is a Registered Trademark
of Bird Electronic Corporation

Safety Precautions

The following are general safety precautions that are not necessarily related to any specific part or procedure and do not necessarily appear elsewhere in this publication. These precautions must be thoroughly understood and apply to all phases of operation and maintenance.

Keep Away From Live Circuits

Operating personnel must at all times observe normal safety regulations. Do not replace components or make adjustments inside the equipment with high voltage turned on. To avoid casualties, always remove power.

Shock Hazard

Do not attempt to remove the RF transmission line while RF power is present.

Do Not Service or Adjust Alone

Under no circumstances should any person reach into an enclosure for the purpose of service or adjustment of equipment except in the presence of someone who is capable of rendering aid.

Safety Earth Ground

An uninterruptible earth safety ground must be supplied from the main power source to test instruments. Grounding one conductor of a two conductor power cable is not sufficient protection. Serious injury or death can occur if this grounding is not properly supplied.

Chemical Hazard

Dry cleaning solvents for cleaning parts may be potentially dangerous. Avoid inhalation of fumes or prolonged contact with skin.

Resuscitation

Personnel working with or near high voltages should be familiar with modern methods of resuscitation.

Safety Symbols

WARNING

Warning notes call attention to a procedure which, if not correctly performed, could result in personal injury.

CAUTION

Caution notes call attention to a procedure which, if not correctly performed, could result in damage to the instrument.



The caution symbol appears on the equipment indicating there is important information in the instruction manual regarding that particular area.

 **NOTE:** Calls attention to supplemental information.

Warning Statements

The following safety warnings appear in the text where there is danger to operating and maintenance personnel and are repeated here for emphasis.

WARNING

Never attempt to connect or disconnect RF equipment from the transmission line while RF power is being applied.
Leaking RF energy is a potential health hazard.

WARNING

Heavy load. Do not attempt to lift unaided.

WARNING

To avoid personal injury, disconnect the power cord from the ac line before performing any maintenance, including fuse replacement or changing the line voltage setting.

WARNING

Exposed ac line voltage (115 VAC or 230 VAC). Disconnect the power cord from the ac line before replacing the batteries. Failure to comply may result in severe electrical shock or death.

WARNING

To avoid personal injury, disconnect the power cord from the ac line before performing any maintenance, including fuse replacement or changing the line voltage setting.

CAUTION

During remote operation, periodically monitor the bus service request line. Failure to detect a service request could result in equipment damage.

Caution Statements

The following equipment cautions appear in the text whenever the equipment is in danger of damage and are repeated here for emphasis.

CAUTION

The interface module contains electrostatic discharge (ESD) sensitive components. Failure to observe ESD precautions can cause permanent damage.

CAUTION

Changing the sensor's connectors will invalidate calibration data, and may reduce the maximum power rating of the unit.

CAUTION

The Bird 4421 must be powered off when connecting or disconnecting the power sensor from the power meter.

CAUTION

Do not use the power sensor with a load VSWR greater than 2:1. Damage to the power meter, power sensor, or the RF power source could occur.

CAUTION

During remote operation, periodically monitor the bus service request line. Failure to detect a service request could result in equipment damage.

CAUTION

Due to the complexity of the Bird Power Sensor, field repairs beyond general maintenance should not be attempted. Removal or disturbance of the power sensor cover can result in cancellation of lifetime warranty.

CAUTION

Failure to install the properly rated fuse may result in equipment damage or nuisance failures.

Safety Statements



USAGE

ANY USE OF THIS INSTRUMENT IN A MANNER NOT SPECIFIED BY THE MANUFACTURER MAY IMPAIR THE INSTRUMENT'S SAFETY PROTECTION.

USO

EL USO DE ESTE INSTRUMENTO DE MANERA NO ESPECIFICADA POR EL FABRICANTE, PUEDE ANULAR LA PROTECCIÓN DE SEGURIDAD DEL INSTRUMENTO.

BENUTZUNG

WIRD DAS GERÄT AUF ANDERE WEISE VERWENDET ALS VOM HERSTELLER BESCHRIEBEN, KANN DIE GERÄTESICHERHEIT BEEINTRÄCHTIGT WERDEN.

UTILISATION

TOUTE UTILISATION DE CET INSTRUMENT QUI N'EST PAS EXPLICITEMENT PRÉVUE PAR LE FABRICANT PEUT ENDOMMAGER LE DISPOSITIF DE PROTECTION DE L'INSTRUMENT.

IMPRIEGO

QUALORA QUESTO STRUMENTO VENISSE UTILIZZATO IN MODO DIVERSO DA COME SPECIFICATO DAL PRODUTTORE LA PROIZIONE DI SICUREZZA POTREBBE VENIRNE COMPROMESSA.



SERVICE

SERVICING INSTRUCTIONS ARE FOR USE BY SERVICE-TRAINED PERSONNEL ONLY. TO AVOID DANGEROUS ELECTRIC SHOCK, DO NOT PERFORM ANY SERVICING UNLESS QUALIFIED TO DO SO.

SERVICIO

LAS INSTRUCCIONES DE SERVICIO SON PARA USO EXCLUSIVO DEL PERSONAL DE SERVICIO CAPACITADO. PARA EVITAR EL PELIGRO DE DESCARGAS ELÉCTRICAS, NO REALICE NINGÚN SERVICIO A MENOS QUE ESTÉ CAPACITADO PARA HACERLO.

WARTUNG

ANWEISUNGEN FÜR DIE WARTUNG DES GERÄTES GELTEN NUR FÜR GESCHULTES FACHPERSONAL.

ZUR VERMEIDUNG GEFÄHRLICHE, ELEKTRISCHE SCHOCKS, SIND WARTUNGSARBEITEN AUSSCHLIEßLICH VON QUALIFIZIERTEM SERVICEPERSONAL DURCHZUFÜHREN.

ENTRETIEN

L'EMPLOI DES INSTRUCTIONS D'ENTRETIEN DOIT ÊTRE RÉSERVÉ AU PERSONNEL FORMÉ AUX OPÉRATIONS D'ENTRETIEN. POUR PRÉVENIR UN CHOC ÉLECTRIQUE DANGEREUX, NE PAS EFFECTUER D'ENTRETIEN SI L'ON N'A PAS ÉTÉ QUALIFIÉ POUR CE FAIRE.

ASSISTENZA TECNICA

LE ISTRUZIONI RELATIVE ALL'ASSISTENZA SONO PREVISTE ESCLUSIVAMENTE PER IL PERSONALE OPPORTUNAMENTE ADDESTRATO. PER EVITARE PERICOLOSE SCOSSE ELETTRICHE NON EFFETTUARE ALCUNA RIPARAZIONE A MENO CHE QUALIFICATI A FARLA.



UNITS ARE EQUIPPED WITH RECHARGEABLE BATTERIES. THESE ARE TO BE REPLACED BY AUTHORIZED SERVICE PERSONNEL ONLY!!!

LAS UNIDADES VIENEN EQUIPADAS CON BATERIAS RECARGABLES. ¡¡¡Y SOLAMENTE EL PERSONAL DE SERVICIO AUTORIZADO PUEDE REEMPLAZARLAS!!!

GERÄTE SIND MIT WIEDER AUFLADBAREN BATTERIEN BESTÜCKT. BATTERIEN SIND NUR VON QUALIFIZIERTEM SERICE PERSONAL AUSZUWECHSELN!!!

CES DISPOSITIFS SONT ÉQUIPÉS DE BATTERIES RECHARGEABLES. SEUL LE PERSONNEL D'ENTRETIEN AUTORISÉ EST HABILITÉ À LES REMPLACER !

LE UNITÀ SONO DOTATE DI BATTERIE RICARICABILI, CHE DEVONO DA COME SPECIFICATO DAL PRODUTTORE LA PROTEZIONE DI SICUREZZA POTREBBE VENIRNE COMPROMESSA.



BE SURE THE 115/230V AC VOLTAGE SELECTOR IS SET TO THE PROPER LINE VOLTAGE, AND THE CORRECT AC LINE FUSE IS INSTALLED BEFORE AC POWER IS APPLIED.

S'ASSURER QUE LE SÉLECTEUR DE TENSION 115/230V C.A. EST BIEN RÉGLÉ POUR LA TENSION DU RÉSEAU ET QUE LE FUSIBLE DE LIGNE C.A. CORRECT EST EN PLACE AVANT DE METTRE SOUS TENSION C.A.

CERCIORSE QUE EL SELECTOR DE VOLTAJE DE 115/230V CA ESTE COLOCADO A LA LINEA DE VOLTAJE APROPIADA Y QUE EL FUSIBLE ESTE INSTALADO A LA LINEA CA ANTES DE APLICAR LA CORRIENTE ALTERNA.

VOR EINSCHALTEN DER WECHSELSTROMZUFUHR SICHERSTELLEN, DASS DER 115/230V WECHSELSPANNUNGS-SELEKTOR AUF DIE VORSCHRIFTSMÄSSIGE LEITUNGSSPANNUNG EINGESTELLT UND DIE RICHTIGE WECHSELSTROM-HAUPTSICHERUNG EINGESETZT IST.

PRIMA DI EROGARE CORRENTE, ASSICURARSI CHE IL SELETTORE DI VOLTAGGIO 115/230 V.C.A. SIA REGOLATO CORRETTAMENTE E CHE IL FUSIBILE ADATTO ALLA LINEA DI ALIMENTAZIONE C.A. SIA INSTALLATO.

About This Manual

This manual covers the Bird 4421 RF Power Meter and the sensors it works with. Specific models include:

Power Meter	4421			
4020 Series Sensors	4021	4022	4024	4025
4027A Series Sensors	4027A250K	4027A400K	4027A800K	4027A2M
	4027A4M	4027A10M	4027A12M	4027A25M
	4027A35M	4027A60M	4027A100M	4027A150M
4027F Series Sensors	4027F2M	4027F10M	4027F60M	
4028A Series Sensors	4028A250K	4028A400K	4028A2M	4028A3M
	4028A4M	4028A10M	4028A25M	
4028B Series Sensors	4028B10M	4028B3M		
4028C Series Sensors	4028C10M			

This instruction book is arranged so that essential safety information appears in the front of the book. Reading the Safety Precautions before operating the equipment is strongly advised.

The remainder of this manual is divided into Chapters and Sections. At the start of each chapter, a general overview describes its contents.

Operation

First time users should read Chapter 1 – Introduction and Chapter 2 – Installation to get an overview of equipment capabilities and installation. Experienced operators can refer to Chapter 3 – Operating Instructions. All instructions necessary to manually operate the equipment appear in this chapter. If the power meter is equipped with a IEEE-488 GPIB Interface refer to Chapter 4 – IEEE-488 GPIB Interface. For the RS-232 Interface refer to Chapter 5 – RS-232 Interface.

Maintenance

You should be familiar with preventative maintenance found in Chapter 6 – Maintenance. If a failure should occur, the troubleshooting section will aid in isolating and repairing the failure. A list of replacement parts with part numbers is also in this chapter.

Changes To This Manual

We have made every effort to ensure this manual is accurate. If you should discover any errors, or if you have suggestions for improving this manual, please send your comments to our factory. This manual may be periodically updated. When inquiring about updates to this manual refer to the part number and revision level on the title page.

Table of Contents

Introduction	1
Power Meter	1
Items Supplied	1
Optional Accessories	1
Power Sensors	2
4020 Series	2
4027A Series	3
4027F Series	3
4028 Series	3
Frequency and Power Ranges	5
4020 Series	5
4027A Series	5
4027F Series	5
4028 Series	6
Installation	7
Sensor Connection	7
RF Line Connection	7
Panel Mounting the 4421 Power Meter	8
Handle Operation	9
115/230V AC Input Power	9
AC Line Connectors	9
Operating Instructions	11
Push Button Functions	11
Error Codes	12
Audible Warning	12
IEEE-488 GPIB Interface	13
Description	13
Cable Connector	13
Interface Capabilities	14
Indicators	14
Setup	15
Dip Switch	15
Talker-Only Mode	15
Command Syntax	15
General Bus Commands	16
Device Dependent Commands	20
RS-232 Interface	29
Description	29
Cable Connector	29
Indicators	29
Setup	30
DIP Switch	30
Auto Baud	31
Talker-Only Mode	31
Command Syntax	31
General Bus Commands	32

Device Dependent Commands	34
Maintenance	41
Cleaning	41
Troubleshooting	41
Functional Test	43
Push Button Test	44
Repair	45
Front Panel (Cal Cart only)	45
Cord Reel (Cal Cart only)	45
Replacing Fuses	46
Replacing Batteries	47
Power Sensor (Cal Cart only)	48
Load	49
Casters	49
Handle	49
Storage and Shipment (Cal Cart only)	49
Specifications, Cal Cart	50
Specifications, 4421 Power Meter	51
Specifications, Power Sensors	52
Specifications, RS-232 Interface	56
Specifications, IEEE-488 GPIB Interface	57
Replacement Parts	58
Customer Service	59

Power Meter

The Bird 4421 RF Power Meter is one component of a complete RF power measurement system. An RF power sensor such as a Bird 4021 is also required. The system can be controlled with the front panel buttons, or remotely through an RS-232 connection or a GPIB-488 connection.

Items Supplied

- Bird 4421 RF Power Meter
- AC Power Cord
- Sensor Cable
- Instruction Manual

Optional Accessories

Panel Mount Kit (P/N 4421-250): Allows the Bird 4421 to be installed in a standard 19" panel for rack mount applications.

Null Modem Kit (P/N 4380-250): Contains the hardware necessary to allow the 4421 to be remotely controlled by controllers with different wiring arrangements. Requires an RS-232 interface module.

Figure 1
Bird 4421 Meter
Outline Drawing

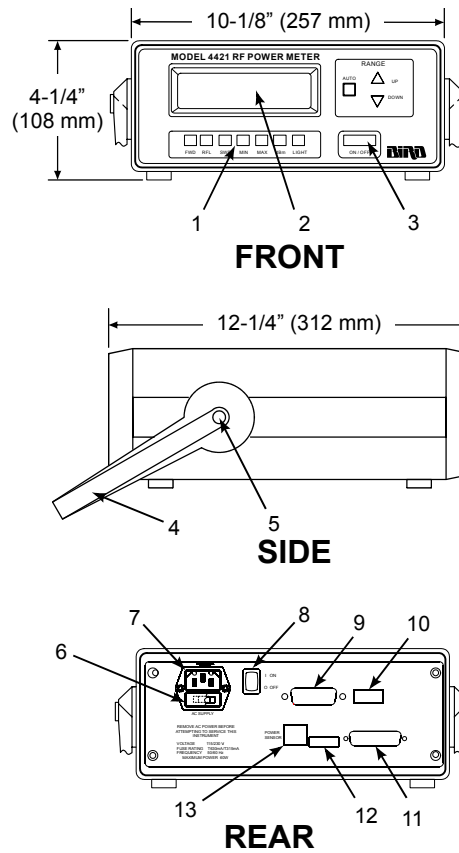

1. Operating Push Buttons
2. LCD
3. ON/OFF Push Button
4. Handle
5. Central Button
6. Fuse Access Door
7. AC Line Module
8. Master ON/OFF Switch
9. GPIB connector
10. GPIB DIP switches
11. RS-232 connector
12. RS-232 DIP switches
13. Power Sensor Socket

Power Sensors

Power sensors are available with a variety of connectors; see Chapter 6 "Available Connectors", page 59 for a complete list. Since the accuracy is critically dependent on the connectors used at calibration, do not remove or change the connectors.



CAUTION

Changing the sensor's connectors will invalidate calibration data, and may reduce the maximum power rating of the unit.

4020 Series

Bird 4020 Series Power Sensors are designed for lab or field use and are accurate to within $\pm 3\%(1\sigma)$ of reading.

4027A Series

Bird 4027A Series Power Sensors are designed for use in semiconductor processing and calibration applications. Stringent calibration provides long-term unit-to-unit repeatability, allowing consistent amounts of RF energy to be applied to the etch process over many etch cycles. 4027A Sensors are accurate to $\pm 1\%(1\sigma)$ at specified calibration frequencies and power levels.

4027F Series

Bird 4027F Series Power Sensors are similar to the 4027A series. However, additional filtering allows the 4027F to ignore harmonics of the signal being measured. The 4027F is also less sensitive to AM components of the signal. 4027F Sensors are accurate to $\pm 1\%(2\sigma)$ at specified calibration frequencies and power levels.

*Figure 2
Power Sensor
Outline Drawing,
4020, 4027A, 4027F,
and 4028A Series*

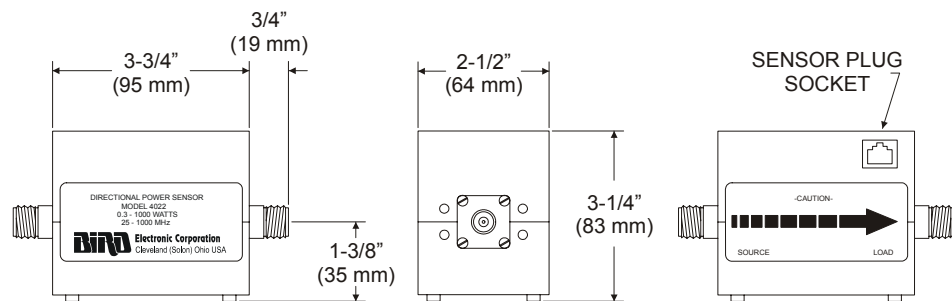

4028 Series

Bird 4028 Series Power Sensors are high power sensors otherwise similar to the 4027A series. 4028A sensors are based on a 7/8" line, 4028B sensors use a 1-5/8" line, and 4028C sensors use a 3-1/8" line. 4028 Sensors are accurate to $\pm 2\%$ at specified calibration frequencies and power levels.

*Figure 3
Power Sensor
Outline Drawing
4028B Series only*

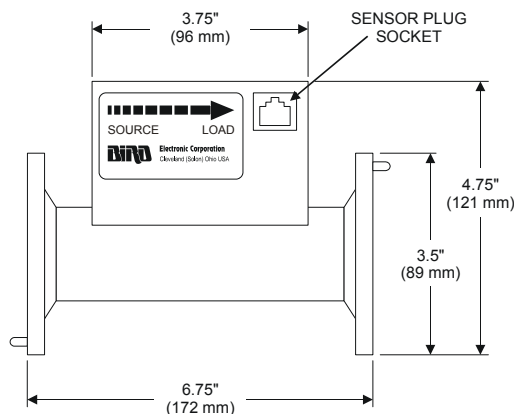
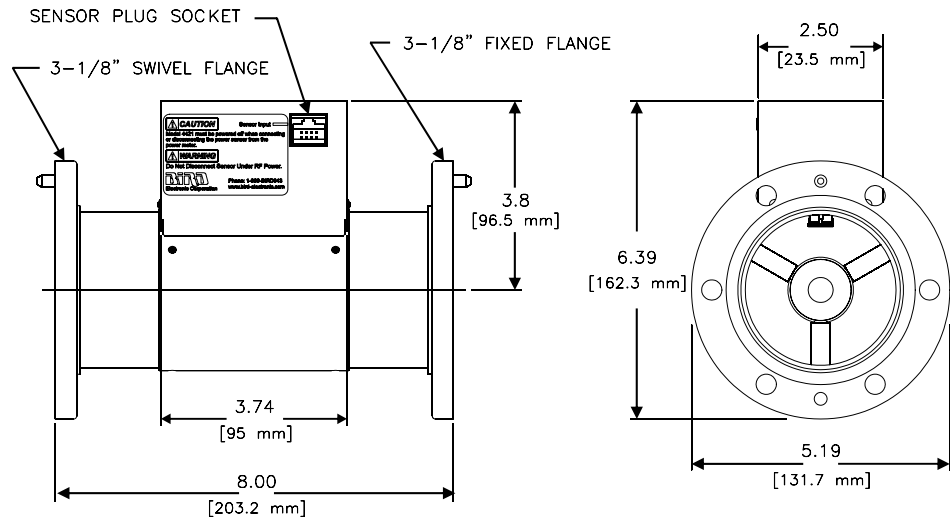

Figure 4
Power Sensor
Outline Drawing
4028C Series only



Frequency and Power Ranges

4020 Series

Model	Frequency Range	RF Power Range
4021	1.8 – 32 MHz	300 mW – 1 kW
4022	25 – 1000 MHz	300 mW – 1 kW
4024	1.5 – 32 MHz	3 W – 10 kW
4025	100 kHz – 2.5 MHz	3 W – 10 kW

4027A Series

4027A250K	250 – 400 kHz	3 W – 10 kW
4027A400K	400 – 550 kHz	3 W – 10 kW
4027A800K	800 – 950 kHz	3 W – 10 kW
4027A2M	1.5 – 2.5 MHz	3 W – 10 kW
4027A4M	3 – 5 MHz	3 W – 10 kW
4027A10M	10 – 15 MHz	3 W – 10 kW
4027A12M	10 – 15 MHz	300 mW – 1 kW
4027A25M	25 – 30 MHz	3 W – 9 kW
4027A35M	35 – 45 MHz	3 W – 7.5 kW
4027A60M	45 – 65 MHz	3 W – 6 kW
4027A100M	95 – 105 MHz	3 W – 5 kW
4027A150M	150 – 170 MHz	3 W – 4 kW

4027F Series

4027F2M	1.8 – 2.2 MHz	100 W – 10 kW
4027F10M	12 – 15 MHz	100 W – 10 kW
4027F60M	57 – 63 MHz	100 W – 3 kW

4028 Series

4028A250K	250 – 400 kHz	1 kW – 20 kW
4028A400K	400 – 550 kHz	1 kW – 20 kW
4028A2M	1.5 – 2.5 MHz	1 kW – 25 kW
4028A3M	2.5 – 3.5 MHz	1 kW – 25 kW
4028A4M	3.5 – 4.5 MHz	1 kW – 25 kW
4028A10M	10 – 15 MHz	1 kW – 25 kW
4028A25M	25 – 30 MHz	1 kW – 25 kW
4028B3M	2.5 – 40 MHz	1 kW – 25 kW
4028B10M	10 – 15 MHz	1 kW – 25 kW
4028C10M	10 – 15 MHz	500W – 50 kW

This chapter provides information about preparing the Bird 4421 for use.

Sensor Connection

CAUTION

Changing the sensor's connectors will invalidate calibration data, and may reduce the maximum power rating of the unit.

CAUTION

The Bird 4421 must be powered off when connecting or disconnecting the power sensor from the power meter.

1. Turn OFF the ON/OFF rocker switch on the meter's *rear* panel.
2. Align the latch on the cable with the notch of the "Power Sensor" socket on the power meter's rear panel.
3. Insert the cable until it clicks into place.
4. Connect the other end of the sensor cable to the sensor.

RF Line Connection

WARNING

Never attempt to connect or disconnect RF equipment from the transmission line while RF power is being applied. Leaking RF energy is a potential health hazard.

CAUTION

Do not use the power sensor with a load VSWR greater than 2:1. Damage to the power meter, power sensor, or the RF power source could occur.

Connect the end of the power sensor labeled "SOURCE" to the RF source. Connect the end labeled "LOAD" to the load or antenna. Reversing these connections will cause measurement errors.

Panel Mounting the 4421 Power Meter

You can install the 4421 Power Meter in an equipment rack if you have the optional panel mount kit (refer to Optional Accessories, page 1). The panel mount kit includes complete installation instructions. Figure 5 shows the overall dimensions and mounting points for a 4421 Power Meter installed in a panel mount kit.

Note: The power supply interrupt switch for the 4421 Power Meter is located on the rear panel. When you install a unit in a panel mount kit, you need to provide a means to interrupt the power supply that is easily accessible to the user (such as a switch mounted in the panel).

Figure 5 Panel Mounting Dimensions

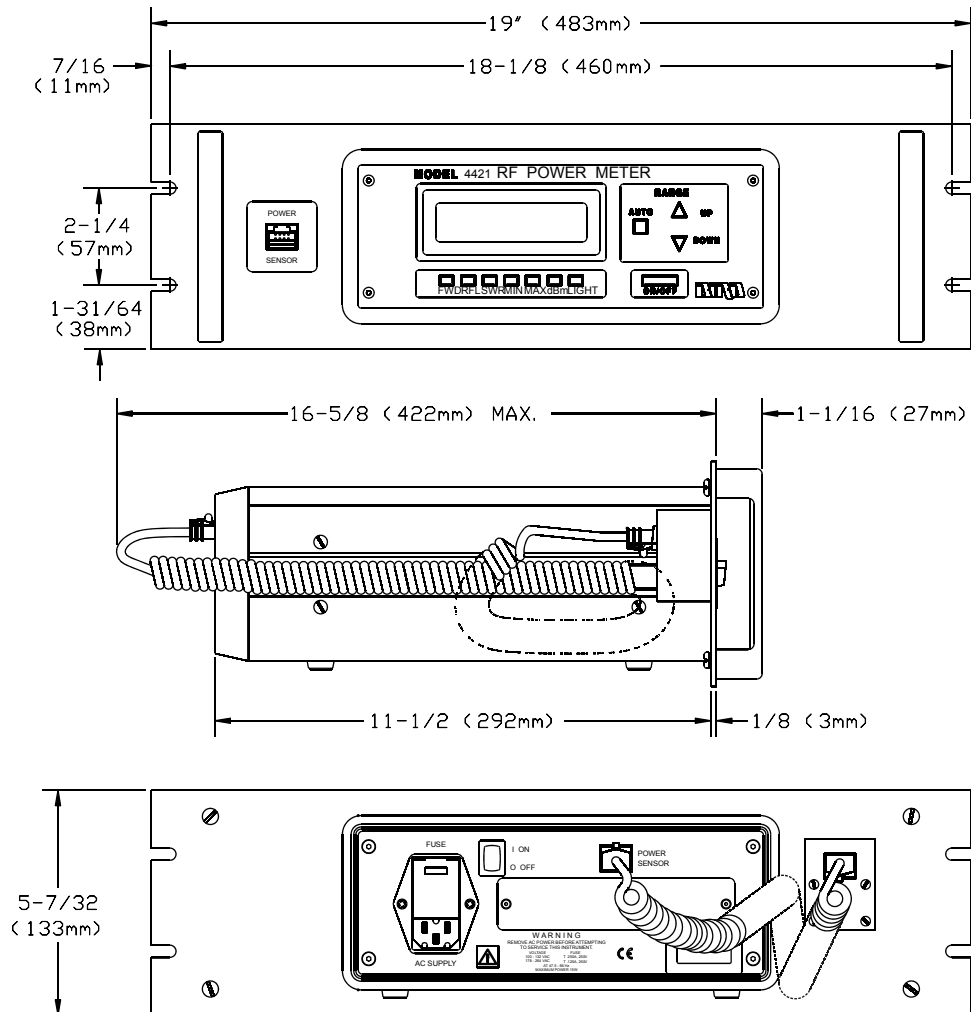

Handle Operation

The handle on the Bird 4421 can be set to four different positions (see Figure 6). To adjust the handle, press the center buttons on both sides. Releasing the buttons will lock the handle into position.

*Figure 6
Handle Positions*

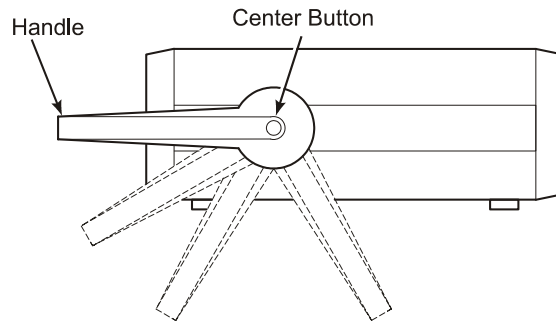

115/230V AC Input Power

The internal power supply can operate at 115 VAC or 230 VAC. There is no user setting to select the input voltage because the power supply automatically senses the input voltage. However, you must make sure that you have the correct power cord plug and fuses installed for the line voltage you are using (refer to Replacing Fuses, page 46).

AC Line Connectors

To make the ac line cord compatible with non-U.S. voltages, users must install the appropriate connector on the power cord.

This chapter describes operator controls and indicators on the Bird 4421 RF Power Meter. For remote operation using a GPIB or RS-232 controller, refer to the instructions in Chapter 4 or Chapter 5 respectively.

Push Button Functions

Figure 7
Push Buttons

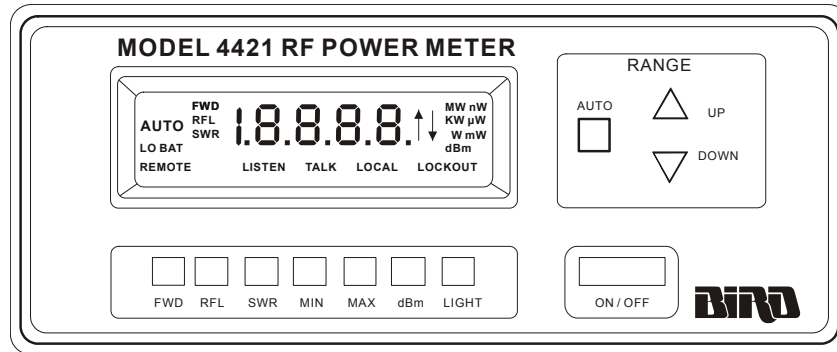

Push Button	Description
FWD, RFL	Press to measure forward or reflected RF power. FWD or RFL indicator and current unit of measure turn on.
SWR	Press to measure standing wave ratio. SWR indicator turns on. Value displayed will be between 1.0 and 199.9
MIN, MAX	Used after pressing FWD, RFL, SWR, or dBm. Displays the minimum (maximum) measured value of the previous function as long as MIN (MAX) is held down.
dBm	Used after pressing FWD or RFL. dBm indicator turns on. Power is displayed in dBm units.
	Used after pressing SWR. Return loss is displayed.
LIGHT	Press to turn on or turn off the display's backlight. If left on, the light automatically shuts off after 30 minutes.
AUTO	Press to automatically set the scale. AUTO turns on.
UP, DOWN	Press to select the next higher (lower) scale. If the scale is too high for the power sensor, an error will be displayed.
	Used while AUTO indicator is on. Stops automatic scaling. AUTO indicator turns off.
ON/OFF	Press to turn the power meter on or off. This switch will not work if the master power switch on the rear panel is OFF. The display flashes for about 30 seconds when the unit is first turned on.

Error Codes

The Bird 4421 displays error codes when the RF power is either below the selected range (underrange) or above the selected range (overrange). Figure 8 displays the error codes and Figure 9 lists the function limits.

Figure 8
Error Codes

Symbol	Explanation
□□	Value greater than overrange limit of function
□□	Value less than underrange limit of function

Figure 9
Function Limits

Function	Limit	Error
FWD, RFL	Power > 199.9% of full scale or 120% of top range	Overrange
FWD dBm, RFL dBm	Power > 120% of full scale Power < 3% of low range	Overrange Underrange
SWR	FWD < 20% of low range FWD – RFL = 0	Underrange Overrange
Return Loss	FWD < 20% of low range RFL < 20% of low range Return Loss > 40 dB	Underrange Underrange Underrange

Audible Warning

If the RF power level exceeds 120% of the power sensor's maximum power capability, the power meter will sound a warning buzzer.

This chapter discusses setup of the IEEE-488 interface feature and describes the IEEE commands that apply to the Bird 4421. Operators should understand IEEE standard 488-1978 and have basic computer programming skills before attempting to write any programs.

CAUTION
 During remote operation, periodically monitor the bus service request line. Failure to detect a service request could result in equipment damage.

Description

The Bird 4421 IEEE-488 (GPIB) interface has an eight-position DIP switch that sets operational conditions and interface addresses. The bottom line of the display indicates the current bus status.

Cable Connector

The interface uses a standard IEEE-488 cable connector. Pin assignments are listed in Figure 10.

*Figure 10
 IEEE-488 Pin
 Assignments*

Pin	Designation	Type
1	D101	Data
2	D102	Data
3	D103	Data
4	D104	Data
5	EOI	Management
6	DAV	Handshake
7	NRFD	Handshake
8	NDAC	Handshake
9	IFC	Management
10	SRQ	Management
11	ATN	Management
12	SHIELD	Ground
13	D105	Data
14	D106	Data
15	D107	Data
16	D108	Data
17	REN	Management
18	GROUND	Ground
19	GROUND	Ground
20	GROUND	Ground
21	GROUND	Ground
22	GROUND	Ground
23	GROUND	Ground
24	GROUND, LOGIC	Ground

Interface Capabilities

The interface capability function codes are listed in Figure 11.

Figure 11
IEEE-488
Interface Module
Capabilities

Code	Name	Description
SH1	Source Handshake	Can handshake data or command bytes when the unit is acting as a source.
AH1	Acceptor	Can handshake the bus when it is acting as the acceptor of data or commands.
T5	Talker	Can send data over the bus to other devices. This capability exists only after the instrument has been addressed to talk, or after a reading in talk-only mode.
L4	Listener	Can receive device-dependent data over the bus. This capability exists only after the unit has been addressed to listen.
SR1	Service Request	Can request service from the controller.
RL1	Remote-Local	Can be placed in remote or local mode.
PP0	Parallel Poll	Does not have parallel polling capability.
DC1	Device Clear	Can be reset to factory settings.
DT1	Device Trigger	Can have its readings triggered.
C0	Controller	Does not have controller capability.
E1	Bus Driver Type	Has open-collector bus drivers.
TE0	Extended Talker	Does not have extended talker capability.
LE0	Extended Listener	Does not have extended listener capability.

Indicators

The bottom line of the power meter's display shows indicators describing the status of the Bird 4421 when used with the IEEE interface. These are:

REMOTE: When REMOTE is displayed, the power meter is being controlled through the interface. Measurements, units of measure, and certain other parameters may be changed from a remote location.

LISTEN: When LISTEN is displayed, the power meter is receiving data.

TALK: When TALK is displayed, the power meter is transmitting data. This is always shown when the unit is in "talker-only" mode.

LOCAL LOCKOUT: When LOCAL LOCKOUT is displayed, the push buttons are disabled and the power meter's functions are being remotely controlled.

Setup

Dip Switch

Set the interface to ADDR (Addressable) by positioning DIP switch 1 to ON. This makes the 4421 respond to controller commands.

Note: There are several button styles on DIP switches (slide, rocker, lever). Examine the DIP switch to determine the ON and OFF positions.

Set the primary address using the DIP switches. The primary address is factory set to 6, but can be set to any value between 1 and 31 (0 is reserved for the controller) To set the primary address, turn OFF switches 4 – 8 so that the sum of the bits turned off equals the desired primary address. In Figure 12 below, the address is set to 6 (the off switches have values of 4 and 2).

Figure 12
IEEE Interface Default
DIP Switch Settings



Note: The primary address is used by the controller to refer to specific devices on the bus. When programming the controller, the address in the program must be the same as the address set on the interface module. Each device on the bus must have a different primary address.

Talker-Only Mode

The Bird 4421 can be set up for manual operation while automatically sending data to an output device (Talker-Only Mode). To do so, turn DIP switch 1 OFF and cycle the power. TALK will be displayed.

In Talker-Only mode, pressing a button on the meter triggers a measurement. When the measurement is complete, the information is sent to the bus and LISTEN turns on momentarily. A listen-only device on the bus, such as a printer, can read the value. The power meter is then ready to accept another button press.

Command Syntax

The Bird 4421 accepts two types of commands. General bus commands are commands, such as Device Clear (DCL), that apply to any IEEE interfaced device. Device-dependent commands are specific to the 4421.

If an invalid command is sent to the unit, an error condition is placed in the serial poll byte and the offending command is not executed.

A group of device-dependent commands can be sent as a single string as long as like command categories are not repeated, for example: “PNFCFDT3TRG”. This string sets up the 4421 to send no prefixes, read forward dBm, make one reading on “TRG”, and triggers a measurement.

Note: Commands can be entered in either upper or lower case.

Note: Only the last command entered of each category will be executed. As a command string is processed by the 4421, each category of command is stored in a separate location. Two commands of the same category will be stored in the same location, so that the second will overwrite and erase the first one.

General Bus Commands

The general bus commands supported by the IEEE-488 interface feature are listed in Figure 13. The syntax for executing general commands varies among controllers; check the documentation supplied with your controller for the proper command structure.

Figure 13
IEEE-488
General Bus
Commands

Command	Effect on Bird 4421
IDN?	Gives product identification
REN	Goes into remote mode when next addressed
GTL	Cancel remote mode, restores local operation
LLO	Locks out local operation
IFC	Goes into talker and listener-idle status
DCL	Returns to default conditions
SDC	Returns to default conditions
GET	Triggers reading in T2 and T3 modes
SPE, SPD	Puts the status byte on the bus

Identification (IDN?)

Function	Product identifies itself
Remarks	Replies command same as U2

Remote ENable (REN)

Function Enables remote operation.

Remarks The unit must be addressed to listen after setting REN true.
The REMOTE indicator turns on when this command is received.

Go To Local (GTL)

Function Returns device to local operation.

Remarks Issuing a GTL command while the device is in Local Lockout mode does not clear the lockout condition.
The REMOTE indicator turns off.
The LISTEN indicator remains on.

Local Lockout (LLO)

Function Disables local operation of all devices on the bus.

Remarks REN must be true to use LLO.
LLO is cleared by setting REN false.

InterFace Clear (IFC)

Function Terminates all bus activity and passes control to the system controller.

Remarks All devices are set to talker and listener idle states.
LISTEN mode is cancelled, and its indicator is turned off.

Device Clear (DCL)

Function Resets the status of all devices to an initialized state.

Remarks Does not change the current interface mode.

The 4421 returns to the factory default condition listed in Figure 14.

*Figure 14
IEEE-488 Default
Conditions*

Default Condition	Related Command
Forward Carrier Wave	FC
Auto Range ON	RYY
Two Terminators (CR LF)	YT
Prefixes YES	PY
Trigger One Shot on Talk Address	T1
All SRQ's OFF	M00
Send EOI with last byte of message	KY

Selective Device Clear (SDC)

Function Resets the status of a selected device to an initialized state.

Remarks Only the device addressed will be cleared.

The 4421 returns to the factory default condition.

Group Execute Trigger (GET)

Function Initiates a measurement for all devices set to trigger on GET.

Remarks The 4421 must be already set to trigger on GET.

Used to synchronize measurements of multiple instruments.

Serial Polling Enable/Disable (SPE/SPD)

Function Enables or disables the serial polling sequence.

CAUTION

During remote operation, periodically monitor the bus service request line.
Failure to detect a service request could result in equipment damage.

Remarks The SPE command puts all devices in serial poll mode waiting to be addressed. The SPD command clears the SRQ bit (bit 6) and ends the polling sequence.

When addressed a device sends its status byte to the controller. A value of 1 for a bit means that the device condition that bit refers to is true. A value of 0 means that the condition is false.

The 4421 does not use all bits of the status byte. Figure 15 lists the bits used, along with a description and how to reset them.

*Figure 15
IEEE Status
Byte Description*

Bit	Name	Condition
6	SRQ	Set if a service request is generated by the 4421. If an SRQ has been received by the controller and this bit is cleared, other instruments on the bus should be checked to determine where the SRQ occurred. Cleared by a serial poll of the 4421.
3	Measurement Complete	Set when the power meter has completed a reading. Cleared by requesting a reading over the bus.
2	Reading Underflow	Set when the RF power is underrange and a reading has been completed. Cleared by requesting a reading over the bus.
1	Reading Overflow	Set when the RF power is overrange and a reading has been completed. Cleared by requesting a reading over the bus.
0	Error	Set if an illegal device-dependent command (IDDC) or illegal device-dependent command option (IDDCO) was received, or if the power meter fails the self test. Cleared by reading the U1 status word. The U1 word contains details on the error, see "Status" on page 25.

Device Dependent Commands

The device-dependent commands used by the 4421 Power Meter are listed in Figure 16, organized by category.

 **Note:** The programming card also has a complete command list.

Figure 16
IEEE-488
Device Dependent
Command
Summary

Category	Command	Description
Measurement	FC	Forward carrier wave
	FD	Forward dBm
	RC	Reflected carrier wave
	RD	Reflected dBm
	SW	Standing wave ratio
	RL	Return loss
	MN	Minimum value
	MX	Maximum value
Range	RYY	Auto range on
	R00 to R17	Manual ranges
	RNN	Auto range off, stay at present range
Terminators	YT	Two terminators: CR, LF
	YO	One terminator: CR
	YN	No terminator
Prefixes	PY	Prefix YES
	PN	Prefix NO
Triggers	T0	Continuous on TALK
	T1	One shot on TALK
	T2	Continuous on GET
	T3	One shot on GET
	T4	Continuous on measurement command
	T5	One shot on measurement command
Serial Polling	M00	Do not generate SRQ
	M01	Generate SRQ on error
	M02	Generate SRQ on measurement overrange
	M04	Generate SRQ on measurement underrange
	M08	Generate SRQ on operation complete
Status	U0	Send back current machine state
	U1	Send back error conditions
	U2	Send back revision levels
Self-Test	J0	Run self-test
EOI Response	KY	Send EOI on last byte
	KN	Do not send EOI on last byte
Writable Store	WXXXXXX	Place XXXXXX in RAM

Forward Carrier Wave (FC)
Forward dBm (FD)
Reflected Carrier Wave (RC)
Reflected dBm (RD)

Function Selects forward or reflected RF power measurement mode.

Remarks Measurement results are returned in Watts or dBm.

Standing Wave Ratio (SW)
Return Loss (RL)

Function Selects SWR or return loss match measurement mode.

Remarks Measurement results are returned in VSWR or dB.

MiNimum Value (MN)
MaXimum Value (MX)

Function Selects minimum or maximum measurement mode.

Remarks Another measurement must be selected before selecting min or max.

Returns the minimum (or maximum) value of the previous measurement type.

Range (Rxx)

Function Selects a measurement range listed in Figure 17.

Remarks If the selected range is outside the range of the connected power sensor, the command is ignored.

*Figure 17
Measurement
Ranges*

Command	Power Range
RYY	Turn auto range on
RNN	Turn auto range off. Keep present range
R17	18.0 – 199.9 MW
R16	1.80 – 19.99 MW
R15	0.180 – 1.999 MW
R14	18.0 – 199.9 kW
R13	1.80 – 19.99 kW
R12	0.180 – 1.999 kW
R11	18.0 – 199.9 W
R10	1.80 – 19.99 W
R09	0.180 – 1.999 W
R08	18.0 – 199.9 mW
R07	1.80 – 19.99 mW
R06	0.180 – 1.999 mW
R05	18.0 – 199.9 μ W
R04	1.80 – 19.99 μ W
R03	0.180 – 1.999 μ W
R02	18.0 – 199.9 nW
R01	1.80 – 19.99 nW
R00	0.180 – 1.999 nW

Terminators (Yx)

Function Selects the characters that follow the end of a data string. Set x to:

- “T” for two terminators; a carriage return(CR) and a line feed(LF).
- “O” for one terminator; a carriage return(CR).
- “N” for no terminator; message can be terminated by EOI.

Remarks Many controllers use the terminator sequence to recognize the end of an input string. Using incorrect terminators can lock the bus.

Prefixes (Px)

Function Turns the prefix mode on or off. Set x to:

- “Y” to enable prefixes.
- “N” to disable prefixes.

Remarks Prefixes are sent over the bus with the measurement, and indicate the status of the current measurement (see Figure 18 for examples):

- “FC”, “FD”, “RC”, “RD”, “SW”, “RL”, “MN”, “MX” indicates the measurement type.
- “U” indicates underflow; the value sent is “.000”.
- “O” indicates overflow; the value sent is “199.9”.
- “N” indicates normal; the value sent is a normal on-scale reading.
- “4421” indicates the Bird model number.

*Figure 18
Prefix Examples*

Data String	Description
NFC.0.123W(CR)(LF)	Normal (N) forward carrier wave (FC), prefixes on
OFC 199.9W(CR)(LF)	Overflowed (O) forward carrier wave (FC), prefixes on
199.9W(CR)(LF)	Overflowed forward carrier wave, prefixes off
URD .000W(CR)(LF)	Underflowed (U) reflected dBm (RD), prefixes on

Triggers (Tx)

- Function** Selects the condition which will trigger a reading (see Figure 19).
- Remarks** Failure to trigger device before requesting a reading will lock the bus.
 T1 halts the bus until a reading is available.
 T0 and T1 do not set the measurement complete SRQ.
 T2, T3, T4, and T5 set a SRQ when the measurement is complete.
 Fastest reading rate is 2.4 readings/second; slowest is 1 reading/sec.

*Figure 19
Trigger Conditions*

Command	Trigger Condition
T0	Continuous on talk
T1	One shot on talk
T2	Continuous on GET
T3	One shot on GET
T4	Continuous on measurement command (FC,FD, RC, RD, SW, RL, MN, MX)
T5	One shot on measurement command (FC, FD, RC, RD, SW, RL, MN, MX)

SRQ Mask (Mxx)

- Function** Selectively masks status bits to prevent unwanted service requests.
 Set xx to the sum of the binary values of the desired SRQ trigger bits. For example, M12 would set the SRQ for both operation complete and underrange (values 8 and 4). Set xx to "00" to never generate an SRQ.
- Remarks** If a status bit is masked (bit set to 0), SRQs won't be generated for that condition.

*Figure 20
SRQ Mask Bits*

Binary Value	Bit Number	Message
1	0 (LSB)	Error (IDDC, IDDCO, self-test fail)
2	1	Measurement overrange
4	2	Measurement underrange
8	3	Operation complete
	4	Not Used
	5	Not Used
	6	Can't mask
	7 (MSB)	Not Used

Status (Ux)

Function Reads a status word and returns the information as a string. Set x to:

- “0” for machine status.
- “1” for error status.
- “2” for revision history.

Remarks After sending the status command, a status word is sent the next time the unit is addressed to talk. To ensure the correct status is transmitted, the status word should be requested as soon as possible after the command is sent.

Machine Status Word (U0): The format of the machine status word is shown in Figure 21. The default values are also shown.

Figure 21
Machine Status
Word Format

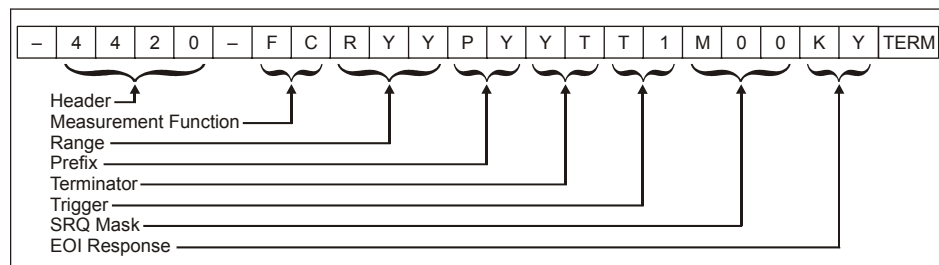

Error Status Word (U1): The format of the error status word and the possible error messages are shown in Figure 22. When an error occurs, an error is also flagged in the status (serial poll) byte, and a SRQ may be generated (See “SRQ Mask” on page 24). All flags will revert to their non-error states after the U1 command is sent.

Figure 22
Error Status
Word Format

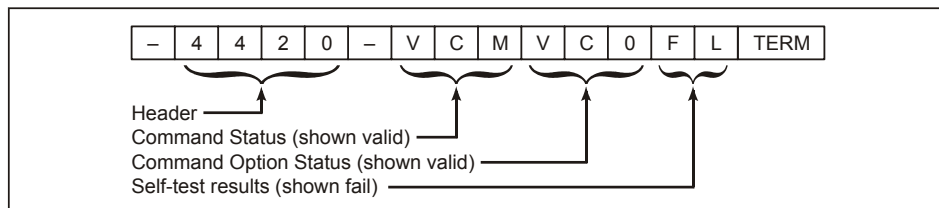

Status	Meaning	Description
ICM	Invalid Command	Set when an illegal device-dependent command (IDDC) such as V2 is received. (V is illegal)
VCM	Valid Command	Set when no IDDC is received.
ICO	Invalid Command Option	Set when an illegal device-dependent command option (IDDCO) such as T6 is received. (6 is illegal)
VCO	Valid Command Option	Set when no IDDCO is received.

PS	Self-Test Pass	Set when a self-test has been initiated by the J0 command and the test result is acceptable.
FL	Self-Test Fail	Set when the self-test has failed. (This is the default condition.)

Revision History Word (U2): The format of the revision history word is shown in Figure 23.

Figure 23
Revision History
Word Format

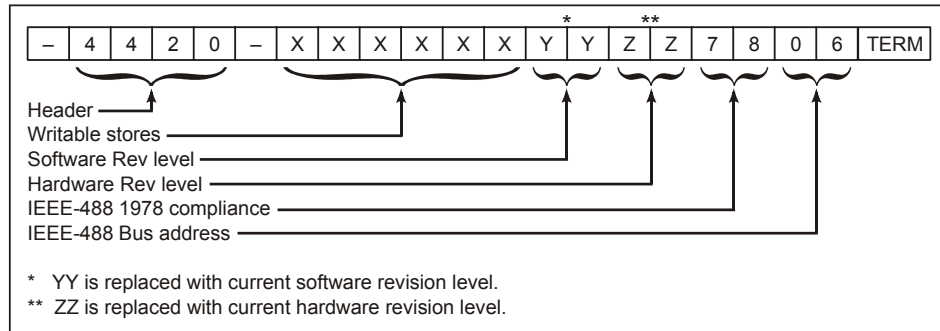

Note: If Writable stores parameter has not been set, this command responds only with -4420-.

Self Test (J0)

- Function** Initiates a hardware and software test.
- Remarks** Results are stored in the U1 status word (see “Status” on page 25).
“J0” must be sent each time before reading the result.

End Or Identify (Kx)

- Function** Enables or disables the End or Identify (EOI) signal. Set x to:
- “Y” to enable.
 - “N” to disable.
- Remarks** Disabling EOI can cause some controllers to lock unless another terminator is used.
When enabled, EOI is only asserted at the end of a multiple byte string.

Writable Store (Wxxxxxx)

Function Storage for six bytes of ASCII data.

Remarks Data stored is lost when the 4421 is turned off.
Data is sent back as part of the U2 status word.

This chapter discusses setup of the RS-232 interface feature and describes the RS-232 commands that apply to the Bird 4421. Operators should understand EIA Standard RS-232-C and have basic computer programming skills before writing any programs.

Description

The Bird 4421 RS-232 interface feature is an integral part of the I/O hub circuit board inside of the mm21. An eight-position DIP switch is used to set operational conditions such as baud rate, parity, and stop bits. The bottom line of the display indicates the current bus status.

Cable Connector

The interface uses a standard 25-pin RS-232 connector. Pin assignments are listed in Figure 24. If the controller uses a different wiring arrangement, do not attempt to rewire the interface module's connector. A null modem kit should be used for rewiring instead.

Figure 24
RS-232 Pin
Assignments

Pin	Designation	Notes
1	Protection Ground	Chassis Ground
2	Transmit Data	
3	Receive Data	
4	Request to Send	(Output) Set true after module power up
5	Clear to Send	(Input) Set by input device. When true, it enables the module to transmit. When false, it disables transmission.
6	Data Set Ready	(Input) Set internally true by module
7	Signal Ground	Return path for data and control signals
8	Receive Signal DET	(Input) Set true by module
20	Data Terminal Ready	(Output) Set true after module power up

Indicators

The bottom line of the power meter's display shows indicators describing the status of the Bird 4421 when used with the RS-232 interface. These are:

TALK: When TALK is displayed, the power meter is transmitting data. This is always shown when the unit is in "talker-only" mode.

LISTEN: When LISTEN is displayed, the power meter is receiving data.

Setup

DIP Switch

Set the DIP switches according to application needs and the requirements of the controller. Available settings and factory defaults are listed in Figure 25.

Note: There are several button styles on DIP switches (slide, rocker, lever). Examine the DIP switch to determine the ON and OFF positions.

Figure 25
RS-232 Interface
Default DIP Switch
Settings

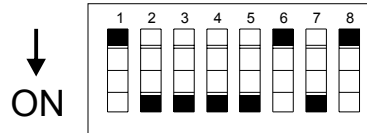

Note: If you change switch settings when the unit is ON, the new settings will not become effective until you turn power OFF and then back ON.

Switch	Function	Description			
1	Stop Bit	ON	1 Stop Bit		
		OFF	2 Stop Bits *		
2	Command Mode	ON	ENT command needed before sending reading to controller*		
		OFF	Trigger automatically sends reading Reading also sent when front panel push button pressed		
3	Word Length	ON	8 Data Bits*		
		OFF	7 Data Bits		
4,5	Parity	(4)	(5)		
		ON	ON	No Parity*	
		ON	OFF	Odd Parity	
		OFF	ON	Even Parity	
		OFF	OFF	Mark Parity	
6,7,8	Baud Rate	(6)	(7)	(8)	
		ON	ON	ON	Auto Baud [†]
		ON	OFF	ON	300
		ON	OFF	OFF	600
		OFF	ON	ON	1200
		OFF	ON	OFF	2400*
		OFF	OFF	ON	4800
		OFF	OFF	OFF	9600

* Default factory setting

[†] For more information see “Auto Baud”

Auto Baud

Auto Baud is used to automatically determine the correct transmission rate. After setting DIP switches 1 through 5, follow the steps below to use auto baud:

1. Set DIP switches 6, 7, and 8 to ON.
2. Connect a controller to the power meter.
3. Turn the power meter on.
4. Send the character U (hexadecimal 55) from the controller to the power meter.
5. Wait 1 second.
6. If the power meter's front panel displays LISTEN, the baud rate has been determined. If not, repeat steps 4 and 5.

If, after 30 seconds, the module cannot absolutely determine a baud rate, it will choose a rate based on data acquired during the test.

 **Note:** Auto Baud is the only automatically chosen setting. Other items such as parity and stop bits must be manually selected.

Talker-Only Mode

The Bird 4421 can be set up for manual operation while automatically sending data to an output device (Talker-Only Mode). To do so, turn DIP switch 2 OFF and cycle the power. TALK will be displayed.

In Talker-Only mode, pressing a button on the meter triggers a measurement. When the measurement is complete, the information is sent to the bus.

Command Syntax

The Bird 4421 accepts two types of commands. General bus commands are commands, such as Initialize (INT), that apply to any RS-232 interfaced device. Device-dependent commands are specific to the 4421.

If an invalid command is sent to the unit, an error condition is placed in the serial poll byte and the offending command is not executed.

A group of device-dependent commands can be sent as a single string as long as like command categories are not repeated. For example: "PNFCFDT3TRG". This string sets up the 4421 to send no prefixes, read forward dBm, make one reading on "TRG", and triggers a measurement.

 **Note:** Commands can be entered in either upper or lower case.

 **Note:** Only the last command entered of each category will be executed. As a command string is processed by the 4421, each category of command is stored in a separate location. Two commands of the same category will be stored in the same location, so that the second will overwrite and erase the first one.

General Bus Commands

The general bus commands supported by the RS-232 interface module are listed in Figure 26.

Figure 26
RS-232
General Bus
Commands

Command	Effect on Bird 4421
INT	Returns to default conditions
ENT	Sends a reading to the controller
TRG	Triggers reading in T3 mode
B1 to B7	Selects a baud rate
XO/XF	Enables/disables software handshake

INiTialize (INT)

Function Resets the Bird 4421 and returns it to the factory defaults.

Remarks If INT is linked with any other command within a string, it must be separated from that command by a space.

ENTer (ENT)

Function Makes the power meter transmit a reading to the controller.

Remarks A measurement must have already been triggered, placing a reading in the output buffer.

To send a reading whenever a measurement is triggered, set DIP switch 2 to OFF. The ENT command will not need to be sent.

TRiGger (TRG)

Function Initiates a measurement if the power meter is in trigger mode (T3).

Baud Select (Bx)

Function Selects a baud rate listed in Figure 27.

Remarks When the meter recognizes a valid Bx command, its baud rate is immediately changed. (The controller is assumed to be transmitting at the new rate; otherwise sending commands would not be possible.)

This command overrides the DIP switch setting.

*Figure 27
Baud Rates*

Command	Baud Rate
B2	300
B3	600
B4	1200
B5	2400
B6	4800
B7	9600

Xmission Flow Control (XO/XF)

Function Enables or disables the XON/XOFF flow control.

- XO enables flow control.
- XF disables flow control.

Remarks When data is being sent from the power meter to the computer and flow control is enabled, data transmission will be suspended when the XOFF character (hexadecimal 13) is sent by the computer. Transmission will resume when XON (hex 11) is sent by the computer.

When data is being sent from the computer to the power meter, XOFF will be sent to the computer when the input buffer fills up. XON will be sent to the computer when the buffer has emptied.

Device Dependent Commands

The device-dependent commands used by the 4421 Power Meter are listed in Figure 28, organized by category.

*Figure 28
RS-232 Device
Dependent
Command
Summary*

Category	Command	Description
Measurement	FC	Forward carrier wave
	FD	Forward dBm
	RC	Reflected carrier wave
	RD	Reflected dBm
	SW	Standing wave ratio
	RL	Return loss
	MN	Minimum value
	MX	Maximum value
Range	RYY	Auto range on
	R00 to R17	Manual ranges
	RNN	Auto range off, stay at present range
Terminators	YT	Two terminators: CR, LF
	YO	One terminator: CR
	YN	No terminator
Prefixes	PY	Prefix YES
	PN	Prefix NO
Triggers	T0	Continuous on ENT
	T1	One shot on ENT
	T3	One shot on TRG
	T5	One shot on measurement command
Status	U0	Send back current machine state
	U1	Send back error conditions
	U2	Send back revision levels
Self-Test	J0	Run self-test
Writable Store	WXXXXXX	Place XXXXXX in RAM

Forward Carrier Wave (FC)
Forward dBm (FD)
Reflected Carrier Wave (RC)
Reflected dBm (RD)

Function Selects forward or reflected RF power measurement mode.

Remarks Measurement results are returned in Watts or dBm.

Standing Wave Ratio (SW)
Return Loss (RL)

Function Selects SWR or return loss match measurement mode.

Remarks Measurement results are returned in VSWR or dB.

Minimum Value (MN)
Maximum Value (MX)

Function Selects minimum or maximum measurement mode.

Remarks Another measurement must be selected before selecting min or max.

Returns the minimum (or maximum) value of the previous measurement type.

Range (Rxx)

Function Selects a measurement range listed in Figure 29.

Remarks If the selected range is outside the range of the connected power sensor, the command is ignored.

*Figure 29
Measurement
Ranges*

Command	Power Range
RYY	Turn auto range on
RNN	Turn auto range off. Keep present range
R17	18.0 – 199.9 MW
R16	1.80 – 19.99 MW
R15	0.180 – 1.999 MW
R14	18.0 – 199.9 kW
R13	1.80 – 19.99 kW
R12	0.180 – 1.999 kW
R11	18.0 – 199.9 W
R10	1.80 – 19.99 W
R09	0.180 – 1.999 W
R08	18.0 – 199.9 mW
R07	1.80 – 19.99 mW
R06	0.180 – 1.999 mW
R05	18.0 – 199.9 μ W
R04	1.80 – 19.99 μ W
R03	0.180 – 1.999 μ W
R02	18.0 – 199.9 nW
R01	1.80 – 19.99 nW
R00	0.180 – 1.999 nW

Terminators (Yx)

Function Selects the characters that follow the end of a data string. Set x to:

- “T” for two terminators; a carriage return(CR) and a line feed(LF).
- “O” for one terminator; a carriage return(CR).
- “N” for no terminator.

Remarks Many controllers use the terminator sequence to recognize the end of an input string. Using incorrect terminators can lock the bus.

Prefixes (Px)

Function Turns the prefix mode on or off. Set x to:

- “Y” to enable prefixes.
- “N” to disable prefixes.

Remarks Prefixes are sent over the bus with the measurement, and indicate the status of the current measurement (see Figure 30 for examples):

- “FC”, “FD”, “RC”, “RD”, “SW”, “RL”, “MN”, “MX” indicates the measurement type.
- “U” indicates underflow; the value sent is “.000”.
- “O” indicates overflow; the value sent is “199.9”.
- “N” indicates normal; the value sent is a normal on-scale reading.
- “4421” indicates the Bird model number.

*Figure 30
Prefix Examples*

Data String	Description
NFC.0.123W(CR)(LF)	Normal (N) forward carrier wave (FC), prefixes on
OFC 199.9W(CR)(LF)	Overflowed (O) forward carrier wave (FC), prefixes on
199.9W(CR)(LF)	Overflowed forward carrier wave, prefixes off
URD .000W(CR)(LF)	Underflowed (U) reflected dBm (RD), prefixes on

Triggers (Tx)

Function Selects the condition which will trigger a reading (see Figure 31).

Remarks Failure to trigger device before requesting a reading will lock the bus.

Fastest reading rate is 2.4 readings/second; slowest is 1 reading/sec.

*Figure 31
Trigger Conditions*

Command	Trigger Condition
T0	Continuous on ENT
T1	One shot on ENT
T3	One shot on TRG
T5	One shot on measurement command (FC, FD, RC, RD, SW, RL, MN, MX)

Status (Ux)

Function Reads a status word and returns the information as a string. Set x to:

- “0” for machine status.
- “1” for error status.
- “2” for revision history.

Remarks After sending the status command, a status word is sent the next time the unit is addressed to talk. To ensure the correct status is transmitted, the status word should be requested as soon as possible after the command is sent.

Machine Status Word (U0): The format of the machine status word is shown in Figure 32. The default values are also shown.

Figure 32
Machine Status
Word Format

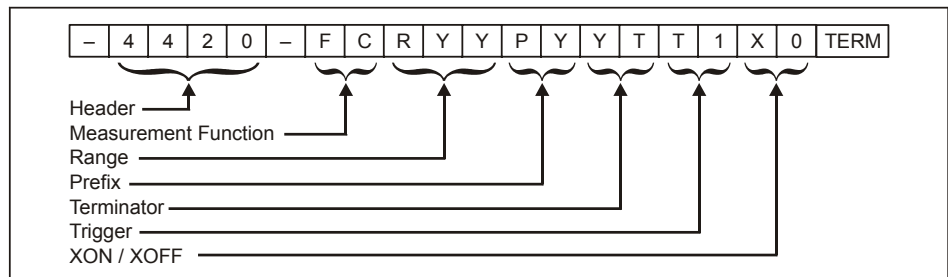

Note: This command sets the unit to the settings that were last issued remotely (through RS-232 or GPIB). Therefore, it will over ride any manual changes selected at the front panel of the unit.

Error Status Word (U1): The format of the error status word and the possible error messages are shown in Figure 33. All flags will revert to their non-error states after the U1 command is sent.

Figure 33
Error Status
Word Format

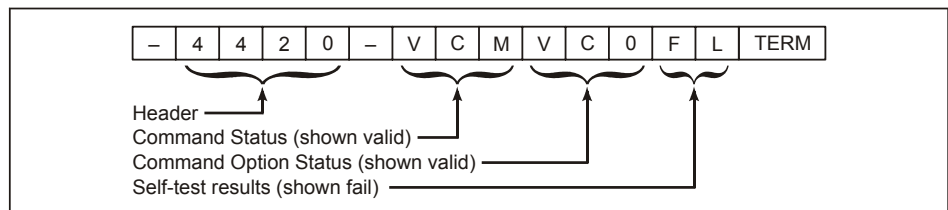

Status	Meaning	Description
ICM	Invalid Command	Set when an illegal device-dependent command (IDDC) such as V2 is received. (V is illegal)
VCM	Valid Command	Set when no IDDC is received.
ICO	Invalid Command Option	Set when an illegal device-dependent command option (IDDCO) such as T6 is received. (6 is illegal)

VCO	Valid Command Option	Set when no IDDCO is received.
PS	Self-test Pass	Set when a self-test has been initiated by the J0 command and the test result is acceptable.
FL	Self-test Fail	Set when the self-test has failed. (This is the default condition.)

Revision History Word (U2): The format of the revision history word is shown in Figure 34.

Figure 34
Revision History
Word Format

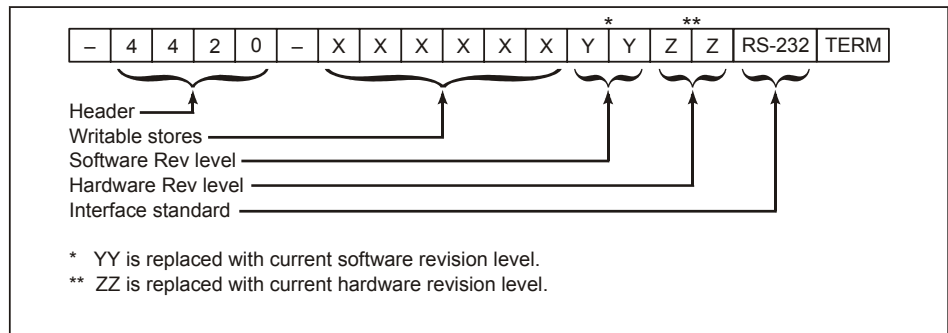

Self Test (J0)

Function Initiates a hardware and software test.

Remarks Results are stored in the U1 status word (see “Status” on page 38).
“J0” must be sent each time before reading the result.

Writable Store (Wxxxxxx)

Function Storage for six bytes of ASCII data.

Remarks Data stored is lost when the 4421 is turned off.
Data is sent back as part of the U2 status word.

This chapter describes routine maintenance, along with troubleshooting instructions for the power meter and power sensor. Disassembly instructions for the Bird Cal Cart are also provided. For service beyond this level, return the unit to a qualified service center.

WARNING

To avoid personal injury, disconnect the power cord from the ac line before performing any maintenance, including fuse replacement or changing the line voltage setting.

WARNING

Never attempt to connect or disconnect RF equipment from the transmission line while RF power is being applied. Leaking RF energy is a potential health hazard.

WARNING

The Bird 4421 contains no user-serviceable parts. Do not remove its cover.

The Bird 4421 Power Meter requires only simple, routine maintenance.

- Wipe off dust and dirt regularly.
- Check the connectors and cables for damage.
- Clean the connector contacts with alcohol or dry cleaning solvent.

Cleaning

CAUTION

Do not use harsh or abrasive detergents for cleaning.

Clean the Bird 4421 Power Meter and its display with a soft cloth dampened with mild detergent and water only. Clean sensors with a dry cleaning solvent that leaves no residue.

Troubleshooting

Since the power meter and power sensor can only work together, the first step is to determine which is malfunctioning. Connect the power sensor to the meter and perform the functional test on page 43. If the power meter is malfunctioning, refer to the troubleshooting table below. If the power sensor is malfunctioning, return it for service.

CAUTION

Due to the complexity of the Bird Power Sensor, field repairs beyond general maintenance should not be attempted. Removal or disturbance of the power sensor cover can result in cancellation of lifetime warranty.

This manual cannot list all malfunctions that may occur, or corrective actions. If a malfunction is not listed or is not corrected by the listed corrective actions, contact a qualified service center.

Note: For power sensors in Cal Carts, following the test procedure will check the sensor not covered by the safety cover. To test the other sensor slide the safety cover over, then proceed as normal.

PROBLEM	POSSIBLE CAUSE	CORRECTION
Power meter has no power	Have the batteries been charged?	Recharge the batteries
	Is the power meter's ac power cord connected?	Connect the power cord
	Is the ON/OFF rocker switch on the rear panel set to OFF?	Set the switch to ON
	<i>(Cal Cart only)</i> Is the Cal Cart's ac power cord connected to the ac line?	Connect ac power
	Blown fuse?	Check fuse rating and replace fuse (See "Replacing Fuses" on page 46)
Dash moves across the display	Is the sensor cable connected to both the power meter and power sensor?	Connect sensor cable
	Is the sensor cable defective?	Replace sensor cable
Display blank or not updating	Have the batteries been charged?	NO: Recharge battery YES: Return meter for service
Power meter turns off while on battery power	Is "LO BAT" displayed?	YES: Recharge battery NO: Return meter for service
Push buttons do not respond	Test the push buttons (See "Push Button Test" on page 44). Are they defective?	Return meter for service.
Every segment on the display is lit		Return meter for service

IEEE-488 Interface does not respond to the interface link	Are the address in the interface program and the address setting on the DIP switches on the interface module the same?	Change the program or DIP switch setting so that the addresses are the same (See “Dip Switch” on page 15)
	Send the “J0” self test command, then check the status. Does the power meter fail the self test?	Replace I/O hub PCB
	Is the IEEE cable defective?	Replace IEEE interface cable
RS-232 Interface does not respond to the interface link. Fails J0 self-test command.	Are the DIP switches set correctly?	Set DIP switches
	Is the RS-232 cable defective?	Replace RS-232 interface cable
With the RS-232, the power meter displays “TALK” but does not operate as expected.	Is DIP switch 2 set correctly?	For “talk/listen” operation, set this switch to ON. For “talk always” set this switch to OFF.
	Is DIP switch 1 set correctly?	Set DIP switch 1 as indicated in Figure 25

Functional Test

This test determines whether the power meter or the sensor is malfunctioning.

1. Turn the power meter off. The ON/OFF switch on the *rear* panel should be OFF and the ac power cable should be connected.
2. Turn ON the ON/OFF switch on the *rear* panel of the meter.
3. While holding down the FWD and SWR push buttons, press the ON/OFF button on the *front* panel of the power meter. Immediately release all three.

The unit tests the display on power up cycling through and activating each segment two times and then activating all segments at once two times.

4. The power meter’s model number and revision date should scroll across the display. If a dash “-” is displayed instead, then the meter is malfunctioning.
5. The power sensor’s model number and revision date should scroll across the display. If a dash is displayed after the power meter data, then the power sensor is malfunctioning.

Figure 35
Test Display,
No Malfunction

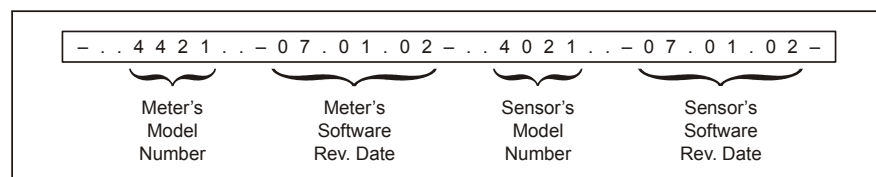

Push Button Test

This test checks that the push buttons and display are functioning properly. If a push button is malfunctioning, return the power meter.

1. Disconnect the power sensor.
2. Turn the power meter ON.
3. After the power up display disappears, a dash “-” should scroll across the display.
4. Turn the power meter OFF.
5. Connect the power sensor.
6. Turn the power meter ON.
7. “AUTO” and “FWD” should be displayed, and a reading of “0.00 W” (or a very low number).
8. Press RFL. “FWD” should change to “RFL” on the display. The reading should remain the same.
9. Press SWR. “RFL” should change to “SWR”. “0.00 W” should change to “□□” (underrange error).
10. Hold down MIN. “□□” should change to “□□” (overrange error).
11. Release MIN. “□□” should change to “□□”.
12. Hold down MAX. “□□” should change to “.000”.
13. Release MAX. “.000” should change to “□□”.
14. Press dBm. “SWR” should turn OFF and “dBm” should turn ON.
15. Press dBm. “dBm” should change to “SWR”.
16. Press FWD. “SWR” should change to “FWD” and “□□” to “.000 W” (or a very low number).
17. Press LIGHT. The back-light should turn on.
18. Press LIGHT. The back-light should turn off.
19. Press ▲ (up). The power meter should change ranges each time it is pressed until it reaches “0.000 KW”.
20. Press ▼ (down). The power meter should change ranges each time it is pressed until it reaches “0.00 W”.
21. Turn the power meter OFF.

Repair

WARNING
 To avoid personal injury, disconnect the power cord from the ac line before performing any maintenance, including fuse replacement or changing the line voltage setting.

Front Panel (Cal Cart only)

If the power meter is mounted in a Cal Cart, to access the power sensor or the ac connections, it will be necessary to remove the front panel of the Cal Cart.

1. Remove both screws on the front panel, between the RF connector and the handle.
2. Pull on the handle set into the base of the front panel to remove it.

When making ac connections, refer to the following wiring diagram.

*Figure 36
 Cal Cart Wiring
 Schematic*

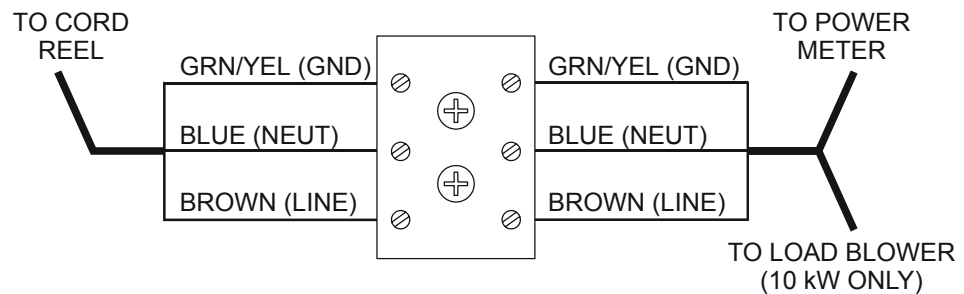

Cord Reel (Cal Cart only)

To replace the cord reel:

1. Disconnect the cord reel from the terminal strip.
2. Unscrew the ac connector.
3. Unscrew and remove the cord reel.
4. Screw the replacement cord reel into place.
5. Thread the ac connector through the grommet, and connect the wires on the other end to the terminal strip (See Figure 36).

Replacing Fuses

WARNING

To avoid personal injury, disconnect the power cord from the ac line before performing any maintenance, including fuse replacement.

CAUTION

Failure to install the properly rated fuse may result in equipment damage or nuisance failures.

1. Gently pry the fuse drawer out of the ac module. The fuse holder does not detach from the ac module.
2. Install the replacement fuses then close and secure the fuse holder. Fuse 1 is a spare fuse and fuse 2 is the active fuse.

AC Line Voltage	Fuse Rating
115 Vac	T630 mA, 5x20 mm Time Lag Fuse
230 Vac	T315 mA, 5x20 mm Time Lag Fuse

Figure 37
AC Line Fuse

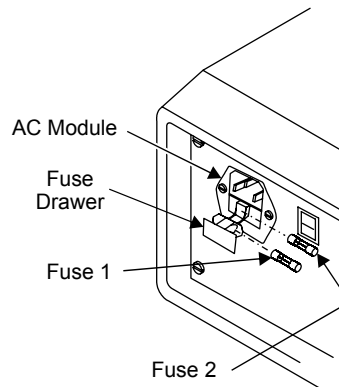

Replacing Batteries

WARNING

Exposed ac line voltage (115 VAC or 230 VAC). Disconnect the power cord from the ac line before replacing the batteries. Failure to comply may result in severe electrical shock or death.

1. Disconnect the ac power cord from the ac mains supply.
2. Remove the four screws that secure the top cover.
3. Lift the top cover to access the attached ground wire then disconnect the ground wire and remove the cover.
4. Unfasten the battery retaining belts then remove the battery tubes (Figure 38). Be sure to note the polarity and orientation of the battery tubes before removing them.
5. Remove the batteries from each tube and insert replacement batteries. Be sure to note the polarity (positive and negative) arrangement of the batteries.
6. Install the battery tubes into the unit and secure with the retaining belts. Be sure to position the retaining belts as they were before removal and tighten them securely.
7. Connect the ground wire to the top cover.
8. Install the top cover and secure it with the four screws removed earlier.

*Figure 38
Batteries*

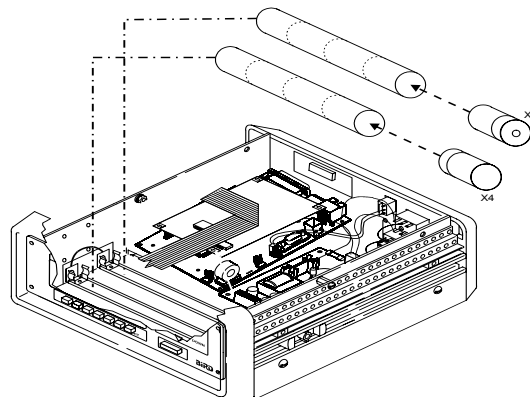

Item	Description
1	Battery retaining belt
2	Battery tube (batteries inside)

Power Sensor (Cal Cart only)

To replace a power sensor:

WARNING

To avoid personal injury, disconnect the power cord from the ac line before performing any maintenance, including fuse replacement or changing the line voltage setting.

WARNING

Never attempt to connect or disconnect RF equipment from the transmission line while RF power is being applied. Leaking RF energy is a potential health hazard.

CAUTION

The Bird 4421 must be powered off when connecting or disconnecting the power sensor from the power meter.

CAUTION

Changing the sensor's connectors will invalidate calibration data, and may reduce the maximum power rating of the unit.

CAUTION

Due to the complexity of the Bird Power Sensor, field repairs beyond general maintenance should not be attempted. Removal or disturbance of the power sensor cover can result in cancellation of lifetime warranty.



1. Disconnect the RF line from the Cal Cart.
 2. Remove the Cal Cart front panel (see Chapter 6 "Front Panel (Cal Cart only)", page 45).
 3. Disconnect the sensor cable from the power sensor.
 4. Disconnect the RF cable from the sensor output port.
 5. Remove the screws on the sensor mounting bracket.
 6. Remove the sensor from the mounting bracket.
 7. Put the new sensor in the bracket and screw it into place.
- Note:** Make sure the arrow on the side of the sensor points towards the load, and that the end labeled "SOURCE" points towards the front of the Cal Cart.
8. Connect the RF cable to the sensor end labeled "LOAD". Connect the sensor cable.
 9. Replace the Cal Cart front panel.

Load

To remove the load from the cart:

WARNING
Heavy load. Do not attempt to lift unaided.

1. Disconnect all RF cables from the RF connectors on the load.
2. On blower-equipped loads, unplug the blower assembly.
3. Replace the vent plugs with the shipping plugs.
4. Remove the mounting bolts connecting the load to the Cal Cart.
5. Remove the load.

Casters

To replace the casters:

1. Remove the load (See Chapter 6 "Load", page 49).
2. Flip the cart over.
3. Unscrew the defective caster.
4. Screw the new caster into place and replace the load.

Handle

To replace the handle:

1. Unscrew and remove the old handle.
2. Screw the new handle into place.

Storage and Shipment (Cal Cart only)

Cover the unit before storing to keep out dust and dirt. It is not necessary to install the shipping plug. Store in a dry, dust-free environment where the ambient temperature will remain between -20 and $+50$ °C (-4 to $+122$ °F).

Before shipping the Bird Cal Cart, take the following precautions:

- Remove the vent plugs and replace them with the shipping plugs. Wrap the vent plugs with padding and tape them to the side of the load for protection.

 **Note:** With the shipping plugs installed, it is not necessary to empty out the coolant.

- Repack in the original carton or contact Bird for a transit case.

Specifications, Cal Cart

To determine the model numbers of the Cal Cart components, refer to the model number breakdown on page viii. For load specifications, refer to the load manual included.

Note: Certain sensors or connectors may be incompatible with some models. Refer to the model number breakdown on page viii for a list of available components, or contact Customer Service.

Max. Power

Under normal operating conditions, the Cal Cart's maximum power is the MINIMUM of the max. power of the sensor and the max. power of the load. The following modifiers apply:

- Above 65 MHz, derate the load's max. power. See Chapter 6 "High Frequency Derating", page 57.
- Due to the wide variety of available connectors, frequency range and maximum power may be reduced. Insertion loss is specified with female N connectors. Choose connectors appropriate for the frequency and power of operation.
- Derate RF power by 2.5% for every 305m (1,000 ft.) above 1,520m (5,000 ft.).

Bird Cal Cart

Frequency Range	Sensor dependent, 30 MHz max.
Power Range	Dependent on sensor, sensor connectors, and load
Connectors	Customer specified (See Chapter 6 "Available Connectors", page 59)
Dimensions	
Short Cart	42"L x 20"W x 42"H (1067 x 508 x 1067 mm)
Long Cart	52"L x 20"W x 42"H (1321 x 508 x 1067 mm)
Weight, Nominal	
Short Cart	175 lbs. (80 kg)
Long Cart	290 lbs. (114 kg)
Temperature Range	
Operating	0 to +35 °C (32 to +95 °F)
Storage	-20 to +70 °C (-4 °F to +158 °F)
Altitude	1520 m (5000 ft.)
Humidity	85% noncondensing max
Calibration Cycle, Nominal	1 year
CE	CE Compliant. Refer to Declaration of Conformity for specific standards.

Specifications, 4421 Power Meter

Bird 4421 RF Power Meter

Frequency Range	Sensor dependent
Power Range	Sensor dependent
VSWR Display	1.0 – 199.9 max
Return Loss Display	0 to 40 dB max
Display Accuracy	± 1 on least significant digit
AC Power	115/230 Vac @ 50/60 Hz; 60 W
Batteries	8 Nickel Metal Hydride 1.2 v cells, rechargeable
Battery Life	Approximately 8 hours continuous usage
Battery Charger	Built-in battery charger. Drained batteries require approximately 28 hours to recharge.
Display	LCD, 4½ digit display. Indicates mode, measurement units, battery condition, remote status, and signal increase/decrease. Self contained backlight.
Optional Interfaces	IEEE-488 GPIB RS-232
Fuse Rating	IEC (5 x 20 mm) Time Lag Type T
115 Vac	T630 mA
230 Vac	T315 mA
CE	CE Compliant. Refer to Declaration of Conformity for specific standards.
Humidity	95% max. (noncondensing)
Altitude	Up to 10,000 feet (3,000 m)
Temperature Range	
Operating	0 to 50 °C (32 to 122 °F)
Storage	-20 to +50 °C (-4 to +122 °F)
Dimensions	15.5”L x 12.25”W x 4.25”H (393 x 311 x 108 mm)
Weight, Nominal	9.5 lbs. (4.3 kg)

Specifications, Power Sensors



CAUTION

Changing the sensor's connectors will invalidate calibration data, and may reduce the maximum power rating of the unit.

Specifications Common to all Sensors

Impedance, Nominal	50 ohms								
Max. Allowable Terminating VSWR	2.00:1								
Calibration Technique	Frequency-specific calibration factors stored in nonvolatile memory in each sensor. Sensor output corrected for frequency and temperature within specified ranges.								
Calibration Cycle, Nominal	4027A and 4027F, 6 months All other models, 1 year								
Accuracy, Reflected	Calculated from FWD accuracy and FWD power $\text{RFL Accuracy} = \text{FWD Accuracy} + \frac{\text{FWD Power}}{10 \text{ Directivity}/10}$								
Accuracy, VSWR	Calculated from FWD and RFL power $\text{VSWR} = \left(1 + \sqrt{\frac{P_R}{P_F}} \right) / \left(1 - \sqrt{\frac{P_R}{P_F}} \right)$								
Sampling Rate, Nominal	2 readings/second								
Operating Power	Supplied by power meter via sensor cable								
Connectors	<table> <tr> <td>4028B10M</td> <td>1-5/8" EIA Flanged</td> </tr> <tr> <td>4028C10M</td> <td>3-1/8" EIA Flanged</td> </tr> <tr> <td>4028A Series</td> <td>7-16 DIN, LC, HN, or 7/8"</td> </tr> <tr> <td>All other models</td> <td>Customer specified from QC list, appropriate for frequency and power.</td> </tr> </table>	4028B10M	1-5/8" EIA Flanged	4028C10M	3-1/8" EIA Flanged	4028A Series	7-16 DIN, LC, HN, or 7/8"	All other models	Customer specified from QC list, appropriate for frequency and power.
4028B10M	1-5/8" EIA Flanged								
4028C10M	3-1/8" EIA Flanged								
4028A Series	7-16 DIN, LC, HN, or 7/8"								
All other models	Customer specified from QC list, appropriate for frequency and power.								
CE	CE Compliant. Refer to Declaration of Conformity for specific standards.								
Humidity, Max.	95% (noncondensing)								
Altitude, Max.	10,000 feet (3,000 m)								
Temperature Range	<table> <tr> <td>Operating</td> <td>0 to 50 °C (32 to 122 °F)</td> </tr> <tr> <td>Storage</td> <td>-20 to +70 °C (-4 to +158 °F)</td> </tr> </table>	Operating	0 to 50 °C (32 to 122 °F)	Storage	-20 to +70 °C (-4 to +158 °F)				
Operating	0 to 50 °C (32 to 122 °F)								
Storage	-20 to +70 °C (-4 to +158 °F)								
Dimensions	<table> <tr> <td>4028B3M, 4028B10M</td> <td>6.75"L x 3.5"W x 4.75"H (175 x 89 x 121 mm)</td> </tr> <tr> <td>4028A Series</td> <td>4.7"L x 3.2"W x 3.8"H (120 x 82 x 97mm)</td> </tr> <tr> <td>All other models</td> <td>5.2"L x 2.5"W x 3.25"H (137 x 64 x 83 mm)</td> </tr> </table>	4028B3M, 4028B10M	6.75"L x 3.5"W x 4.75"H (175 x 89 x 121 mm)	4028A Series	4.7"L x 3.2"W x 3.8"H (120 x 82 x 97mm)	All other models	5.2"L x 2.5"W x 3.25"H (137 x 64 x 83 mm)		
4028B3M, 4028B10M	6.75"L x 3.5"W x 4.75"H (175 x 89 x 121 mm)								
4028A Series	4.7"L x 3.2"W x 3.8"H (120 x 82 x 97mm)								
All other models	5.2"L x 2.5"W x 3.25"H (137 x 64 x 83 mm)								
Weight, Nominal	<table> <tr> <td>4028B3M, 4028B10M, 4028C10M</td> <td>5 lb. 2 oz. (2.33 kg)</td> </tr> <tr> <td>4028A2M, 3M, 4M, 10M, and 25M</td> <td>3 lb. 5 oz. (1.5 kg)</td> </tr> <tr> <td>All other models</td> <td>1 lb. 13 oz. (0.8 kg)</td> </tr> </table>	4028B3M, 4028B10M, 4028C10M	5 lb. 2 oz. (2.33 kg)	4028A2M, 3M, 4M, 10M, and 25M	3 lb. 5 oz. (1.5 kg)	All other models	1 lb. 13 oz. (0.8 kg)		
4028B3M, 4028B10M, 4028C10M	5 lb. 2 oz. (2.33 kg)								
4028A2M, 3M, 4M, 10M, and 25M	3 lb. 5 oz. (1.5 kg)								
All other models	1 lb. 13 oz. (0.8 kg)								

Bird 4020 Series RF Power Sensors

RF Power Range	
4021, 4022	300 mW – 1 kW
4024, 4025	3 W – 10 kW
Frequency Range	
4021	1.8 – 32 MHz
4022	25 MHz – 1 GHz
4024	1.5 – 32 MHz
4025	100 kHz – 2.5 MHz
Accuracy, Fwd, Best Case*	
	± 3% (1σ)
VSWR, Max.	
4021, 4024, 4025	1.05:1
4022	1.05:1, 25 – 512 MHz 1.10:1, 512 MHz – 1 GHz
Insertion Loss, Max.	
4021, 4024, 4025	0.05 dB
4022	0.05 dB, 25 – 512 MHz 0.13 dB, 512 MHz – 1 GHz
Directivity, Min.	
4021, 4022	30 dB
4024	28 dB, 1.5 – 2.5 and 25 – 32 MHz 30 dB, 2.5 – 25 MHz
4025	28 dB, 100 – 125 kHz 30 dB, 125 – 2500 kHz

* For rated accuracy, no more than 1% AM; Harmonics –50 dBc or less
Derate accuracy by 3.0% (1σ) below 15 °C and above 35 °C



CAUTION
Changing the sensor's connectors will invalidate calibration data, and may reduce the maximum power rating of the unit.

Bird 4027A Series RF Power Sensors

Frequency Range			
4027A250K	250 – 400 kHz	4027A12M	10 – 15 MHz
4027A400K	400 – 550 kHz	4027A25M	25 – 30 MHz
4027A800K	800 – 950 kHz	4027A35M	35 – 45 MHz
4027A2M	1.5 – 2.5 MHz	4027A60M	45 – 65 MHz
4027A4M	3 – 5 MHz	4027A100M	95 – 105 MHz
4027A10M	10 – 15 MHz	4027A150M	150 – 170 MHz
RF Power Range			
4027A12M	300 mW – 1 kW	4027A100M	3 W – 5 kW
4027A25M	3 W – 9 kW	4027A150M	3 W – 4 kW
4027A35M	3 W – 7.5 kW	All other models	3 W – 10 kW
4027A60M	3 W – 6 kW		
Accuracy, Fwd, Best Case*			
$\pm 1.0\%$ (1σ)			
Calibration Frequencies, Typical (MHz)†			
4027A250K	0.25, 0.40	4027A12M	10.0, 13.56, 15.0
4027A400K	0.40	4027A25M	25.76, 27.12, 28.48
4027A800K	0.90	4027A35M	40.68
4027A2M	1.8, 2.0, 2.17	4027A60M	55.0, 60.0
4027A4M	4.0, 5.0	4027A100M	95.0, 100.0
4027A10M	10.0, 13.56, 15.0	4027A150M	162.0
Calibration Power, Typical			
4027A12M	700 W		
All other models	1.7 kW		
VSWR, Max.			
1.05:1			
Insertion Loss, Max.			
0.05 dB (with female “N” connectors)			
Directivity, Min.			
4027A12M	30 dB		
All other models	28 dB		

* For rated accuracy, no more than 1% AM; Harmonics –50 dBc or less
Derate accuracy by 1% (1σ) outside cal. power or cal. frequency
Derate accuracy by 1% (1σ) below 15 °C and above 35 °C

† Other calibration frequencies available upon request

Bird 4027F Series RF Power Sensors

Frequency Range	
4027F2M	1.8 – 2.2 MHz
4027F10M	12 – 15 MHz
4027F60M	57 – 63 MHz
RF Power Range	
4027F2M, 4027F10M	0.1 – 10 kW
4027F60M	0.1 – 3 kW
Accuracy, Fwd, Best Case	± 1.0% (2σ)
Calibration Frequencies, Typical*	
4027F2M	1.8, 2.0, 2.17 MHz
4027F10M	12.0, 12.5, 13.56, 14.0, 15.0 MHz
4027F60M	57.0, 58.5, 60.0, 61.5, 63.0 MHz
Calibration Power, Typical	1.7 kW
Harmonic Rejection, Min.	
4027F2M	26 dB @ 3.6 – 3.8 MHz, 30 dB @ > 3.8 MHz
4027F10M	30 dB @ > 25 MHz
4027F60M	30 dB @ > 114 MHz
Low Frequency Rejection, Min.	
4027F10M	30 dB @ < 1 MHz
4027F60M	30 dB @ < 15 MHz
Max Error Induced by 10% AM	
4027F2M, 4027F10M	0.2% @ < 5 kW, 1.0% @ 5 – 10 kW
4027F60M	0.2% @ < 1.5 kW, 1.0% @ 1.5 – 3 kW
VSWR, Max.	1.05:1
Insertion Loss, Max.	0.05 dB (with female “N” connectors)
Directivity, Min.	28 dB

* Other calibration frequencies available upon request

Uncertainty Budget, 4027F Series*		4027F2M	4027F10M	4027F60M
Frequency Error...	at cal freq	± 0.1%	± 0.1%	± 0.1%
	not at cal freq	± 0.5%	± 1.5%	± 0.5%
Power Linearity...	at cal power	± 0.1%	± 0.1%	± 0.1%
	not at cal power	± 1.0%	± 0.5%	± 1.0%
Temperature Uncert...	within 20 to 30°C	± 0.65%	± 0.6%	± 0.5%
	outside 20 to 30°C	± 3.2%	-3.0, +0.75%	± 2.9%
Calibration Uncertainty		± 0.6%	± 0.6%	± 0.6%
Resolution Uncert...	at cal power	± 0.06%	± 0.06%	± 0.06%
	not at cal power†	± 0.34%	± 0.34%	± 0.34%
Other sources of error		± 0.4%	± 0.5%	± 0.6%
Best Case RSS Uncertainty		± 1.0%	± 1.0%	± 1.0%

* All values 2σ

† Resolution uncertainty is error due to limited display digits. Actual uncertainty can be calculated as

$$\pm (1 \text{ in least significant digit}) / \text{Reading}$$

For a 3.5-digit display, worst case is at 300W. Least significant digit is one watt, uncertainty is ± 1W out of 300 or 0.34%. For a 4.5-digit display, least significant digit is 0.1W, so the uncertainty is 0.034%

Bird 4028A and 4028B Series RF Power Sensors

Frequency Range	
4028A250K	250 – 400 kHz
4028A400K	400 – 550 kHz
4028A2M	1.5 – 2.5 MHz
4028A3M	2.5 – 3.5 MHz
4028A4M	3.5 – 4.5 MHz
4028A10M, 4028B10M, 4028C10M	10 – 15 MHz
4028A25M	25 – 30 MHz
4028B3M	2.5 – 40 MHz
RF Power Range	
4028A250K, 4028A400K	1 kW – 20 kW
4028C10M	500W – 50 kW
All other models	1 kW – 25 kW
Accuracy, Fwd, Best Case*	± 2.0% (2σ)
Calibration Frequencies, Typical (MHz)†	
4028A250K	0.25, 0.40
4028A400K	0.40
4028A2M	1.8, 2.0, 2.17
4028A3M	2.5, 3.2, 3.5
4028A4M	3.5, 4.0
4028A10M, 4028B10M, 4028C10M	10.0, 13.56, 15.0
4028A25M	25.76, 27.12, 28.48
4028B3M	2.5, 3.2, 3.5, 4.0
Calibration Power, Typical	3.5 kW
VSWR, Max.	1.05:1
Insertion Loss, Max.	0.05 dB (with female 7-16 DIN connectors)
Directivity, Min.	28 dB

* For rated accuracy, no more than 1% AM; Harmonics –50 dBc or less

Derate accuracy by 2% (2σ) outside cal. power or cal. frequency

Derate accuracy by 2% (2σ) below 15 °C and above 35 °C

† Other calibration frequencies available upon request

Specifications, RS-232 Interface

RS-232 Interface Module

Logic Levels	Meets all EIA Standard RS-232-C specifications
Modes of Operation	Switch and bus selectable
Talk Always	Allows the 4421 to send to the bus keyboard-initiated measurements only
Addressable	Allows the 4421 to be commanded by an RS-232 interface controller
Connector	RS-232 Interface Type
Humidity, Max	95% (non-condensing)
Altitude, Max	10,000 feet (3,000 m)
Temperature Range	
Operating	0 to 50° C (32 to 122° F)
Storage	–20 to +50° C (–4 to +122° F)

Dimensions	6.5"L x 4.5" W (165 x 115 mm)
Weight	0.5 lbs (0.23 kg) nominal

Specifications, IEEE-488 GPIB Interface

IEEE-488 Interface

Logic Levels	Meets all IEEE Standard 488-1978 specifications
Modes of Operation	Switch and bus selectable
Talk Only	Allows the 4421 to send to the bus keyboard-initiated measurements only
Addressable	Allows the 4422 to be addressed as talker or listener under the command of an IEEE-488 bus controller
Connector	Standard IEEE-488 bus type
Humidity, Max	95% (non-condensing)
Altitude, Max	10,000 feet (3,000 m)
Temperature Range	
Operating	0 to 50° C (32 to 122° F)
Storage	-20 to +50° C (-4 to +122° F)
Dimensions	6.5"L x 4.5" W (165 x 115 mm)
Weight, Nominal	0.5 lbs (0.23 kg)

High Frequency Derating

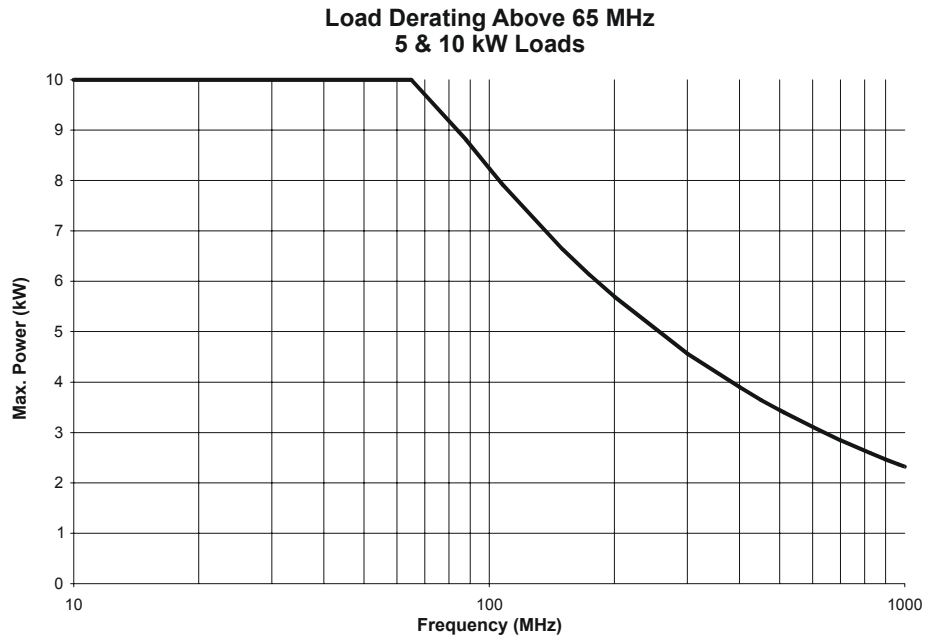

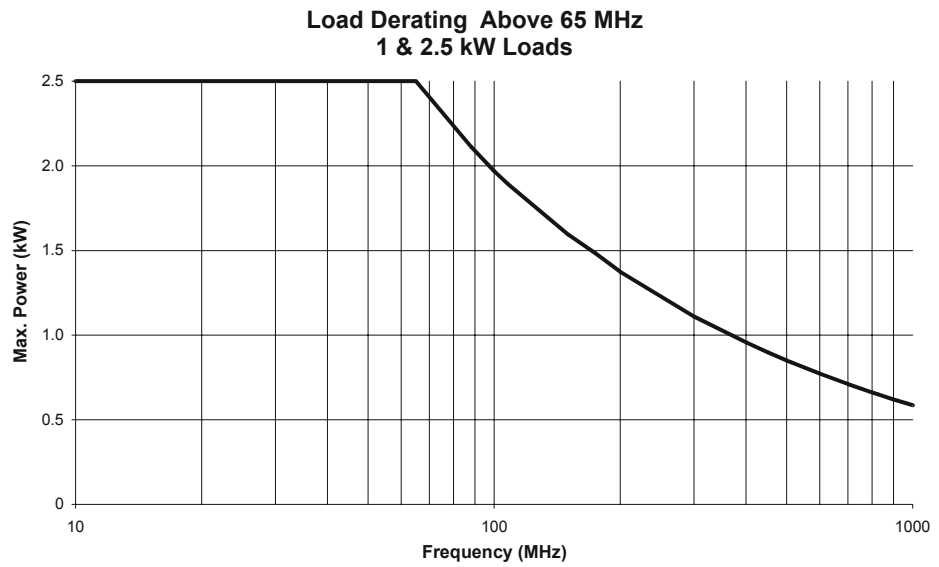

Replacement Parts

Description	Qty	Part Number
Fuse, IEC (5 x 20 mm) Time Lag Type T 115 Vac, T630 mA 230 Vac, T315 mA	1	5A2257-10 5A2257-7
Cord, AC Power 115 Vac 230 Vac Harmonized	1	5-1286 5A2416
Plug, 115 Vac	1	5A2626
Cable, Sensor	1	4421-038
Grommet	1	4421A372
Cordreel	1	4421A383
Casters	4	4421A384
Handle	1	4421A385
IEEE-488 Bus Interface Module	1	4421-489-2
Cable, IEEE-488 2 m 1 m	1	5-1317-2 5-1317-1
RS-232 Bus Interface Module	1	4421-233-1
Cable, RS-232 10 ft. 5 ft.	1	5-1662-2 5-1662-1
Null Modem Kit (RS-232 only)	1	4380-250
Panel Mount Kit	1	4421-250
Battery, C size, NiMH	8	5A1230

Available Connectors



CAUTION

Changing the sensor's connectors will invalidate calibration data, and may reduce the maximum power rating of the unit.

Connector	Part Number	Connector	Part Number	Connector	Part Number
HN (F)	4240-268	N (F)	4240-062	TRU 6934 (F)	4240-371
LC (F)	4240-031	7/16 Jack, IEC Type 169-4	4240-344	TRU 7958 (F)	4240-372

Connector	P/N	Connector	P/N	Connector	P/N
BNC-Female	4240-125	LT-Female	4240-018	Mini UHF-Female	4240-346
BNC-Male	4240-132	LT-Male	4240-012	UHF-Female	4240-050
C-Female	4240-100	N-Female	4240-062	UHF-Male	4240-179
C-Male	4240-110	N-Male	4240-063	1-5/8" EIA Fixed	4240-096
HN-Female	4240-268	SC-Female	4240-090	1-5/8" EIA Swivel	4240-208
HN-Male	4240-278	SMA-Female	4240-336	7/8" EIA	4240-002
LC-Female	4240-031	SMA-Male	4240-334	TNC-Female	4240-156
LC-Male	4240-025	7/16 Jack, IEC Type 169-4	4240-344	TNC-Male	4240-160
Open Term. # 10-32 Nut	4240-080	7/16 Plug, IEC Type 169-4	4240-363		

Customer Service

If you need to return the unit for any reason, contact the Bird Service Center for a return authorization. All instruments returned must be shipped prepaid and to the attention of Bird Service Center.

Bird Service Center

30303 Aurora Road
Cleveland (Solon), Ohio 44139-2794
Phone: (440) 519-2298
Fax: (440) 519-2326
E-mail: bsc@bird-technologies.com

For the location of the sales office nearest you, give us a call or visit our Web site at:

<http://www.bird-electronic.com>

Limited Warranty

All products manufactured by Seller are warranted to be free from defects in material and workmanship for a period of one (1) year, unless otherwise specified, from date of shipment and to conform to applicable specifications, drawings, blueprints and/or samples. Seller's sole obligation under these warranties shall be to issue credit, repair or replace any item or part thereof which is proved to be other than as warranted; no allowance shall be made for any labor charges of Buyer for replacement of parts, adjustment or repairs, or any other work, unless such charges are authorized in advance by Seller.

If Seller's products are claimed to be defective in material or workmanship or not to conform to specifications, drawings, blueprints and/or samples, Seller shall, upon prompt notice thereof, either examine the products where they are located or issue shipping instructions for return to Seller (transportation-charges prepaid by Buyer). In the event any of our products are proved to be other than as warranted, transportation costs (cheapest way) to and from Seller's plant, will be borne by Seller and reimbursement or credit will be made for amounts so expended by Buyer. Every such claim for breach of these warranties shall be deemed to be waived by Buyer unless made in writing within ten (10) days from the date of discovery of the defect.

The above warranties shall not extend to any products or parts thereof which have been subjected to any misuse or neglect, damaged by accident, rendered defective by reason of improper installation or by the performance of repairs or alterations outside of our plant, and shall not apply to any goods or parts thereof furnished by Buyer or acquired from others at Buyer's request and/or to Buyer's specifications. Routine (regularly required) calibration is not covered under this limited warranty. In addition, Seller's warranties do not extend to the failure of tubes, transistors, fuses and batteries, or to other equipment and parts manufactured by others except to the extent of the original manufacturer's warranty to Seller.

The obligations under the foregoing warranties are limited to the precise terms thereof. These warranties provide exclusive remedies, expressly in lieu of all other remedies including claims for special or consequential damages. SELLER NEITHER MAKES NOR ASSUMES ANY OTHER WARRANTY WHATSOEVER, WHETHER EXPRESS, STATUTORY, OR IMPLIED, INCLUDING WARRANTIES OF MERCHANTABILITY AND FITNESS, AND NO PERSON IS AUTHORIZED TO ASSUME FOR SELLER ANY OBLIGATION OR LIABILITY NOT STRICTLY IN ACCORDANCE WITH THE FOREGOING.

Special Lifetime Warranty - Series 4020, Series 4027A, Series 4027F, and Series 4028 Power Sensor Head

In addition to its standard warranty, the Bird Electronic Corporation warrants its Series 4020, Series 4027A, Series 4027F, and Series 4028 Thruline® Power Sensor Heads for lifetime to original purchaser. This extended warranty is against burnout. For the warranty to apply, the Sensor Head must be used with the correct Bird Electronic Corporation Display Unit, the maximum power rating of the Sensor must not be exceeded, the Sensor RF circuit must be properly terminated and the Sensor not subjected to physical abuse.

Bird Electronic Corporation, at its option, will repair or replace the defective Sensor at its world Headquarters at 30303 Aurora Road, Solon, Ohio 44139.

The customer is responsible to pay transportation charges to return the defective sensor to Bird.