INSTRUCTION BOOK

**BROADCAST POWER MONITOR
SERIES BPM AND
MODEL 3129 BPM DISPLAY**



Bird® Electronic Corporation
30303 Aurora Road
Cleveland (Solon), Ohio 44139

Sales & Technical Support: 440-248-1200
866-695-4569 toll free

Sales email: sales@bird-technologies.com

Technical Support email: atechapp@bird-technologies.com

©*Copyright* 2005 by Bird Electronic Corporation
Instruction Book P/N 920-7005A900S Rev. I
ThruLine® is a registered trademark of
Bird Electronic Corporation

Microsoft® and Windows® are registered
trademarks of the Microsoft Corporation

Safety Precautions

The following are general safety precautions that are not necessarily related to any specific part or procedure, and do not appear elsewhere in this publication. These precautions must be thoroughly understood and applied to all phases of operation and maintenance.

Keep Away From Live Circuits

Operating personnel must at all Century Schoolbook observe general safety precautions. Do not replace components or make adjustments to the inside of the test equipment with the high voltage supply turned on. To avoid casualties, always remove power.

Shock Hazard

Do not attempt to disconnect an RF transmission line while RF power is present. Radiated RF power is a potential health hazard.

Do Not Service or Adjust Alone

Under no circumstances should any person reach into an enclosure to service or adjust the equipment, except in the presence of someone who is capable of rendering aid.

Safety Earth Ground

An uninterruptible safety earth ground must be supplied from the main power source to the test instruments. Grounding one conductor of a two conductor power cable is not sufficient protection. Serious injury or death can occur if this grounding is not properly installed.

Resuscitation

Personnel working with or near high voltages should be familiar with modern methods of resuscitation.

Safety Symbols

WARNING

Warning notes call attention to a procedure, which if not correctly performed, could result in personal injury

CAUTION

Caution notes call attention to a procedure, which if not correctly performed, could result in damage to the instrument.



The caution symbol appears on the equipment indicating there is important information in the instruction manual regarding that particular area.

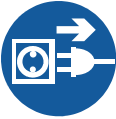

This symbol indicates that the ac power cord should be removed before servicing the unit.

 **NOTE:** Calls attention to supplemental information.

Warning Statements

The following warnings appear in the text where there is danger to operating and maintenance personnel, and are repeated here for emphasis.

WARNING

Leaking RF energy is a potential health hazard. Never attempt to connect or disconnect equipment from the transmission line while RF power is being applied. Severe burns, electrical shock, or death can occur.

WARNING

Disconnect the unit from the RF power source and the ac line before any disassembly. The potential for electrical shock exists.

WARNING

Shock hazard. Remove ac power before attempting to service the equipment.

Caution Statement

The following equipment caution appears in the text whenever the equipment is in danger of damage, and is repeated here for emphasis.

CAUTION

Do not use harsh or abrasive detergents for cleaning.

CAUTION

The 3129 parallel port should only be used to power the BPM.
Do not connect anything else to the 3129.

Safety Statements



USAGE

ANY USE OF THIS INSTRUMENT IN A MANNER NOT SPECIFIED BY THE MANUFACTURER MAY IMPAIR THE INSTRUMENT'S SAFETY PROTECTION.

USO

EL USO DE ESTE INSTRUMENTO DE MANERA NO ESPECIFICADA POR EL FABRICANTE, PUEDE ANULAR LA PROTECCIÓN DE SEGURIDAD DEL INSTRUMENTO.

BENUTZUNG

WIRD DAS GERÄT AUF ANDERE WEISE VERWENDET ALS VOM HERSTELLER BESCHRIEBEN, KANN DIE GERÄTESICHERHEIT BEEINTRÄCHTIGT WERDEN.

UTILISATION

TOUTE UTILISATION DE CET INSTRUMENT QUI N'EST PAS EXPLICITEMENT PRÉVUE PAR LE FABRICANT PEUT ENDOMMAGER LE DISPOSITIF DE PROTECTION DE L'INSTRUMENT.

IMPIEGO

QUALORA QUESTO STRUMENTO VENISSE UTILIZZATO IN MODO DIVERSO DA COME SPECIFICATO DAL PRODUTTORE LA PROZIONE DI SICUREZZA POTREBBE VENIRNE COMPROMESSA.



SERVICE

SERVICING INSTRUCTIONS ARE FOR USE BY SERVICE - TRAINED PERSONNEL ONLY. TO AVOID

DANGEROUS ELECTRIC SHOCK, DO NOT PERFORM ANY SERVICING UNLESS QUALIFIED TO DO SO.

SERVICIO

LAS INSTRUCCIONES DE SERVICIO SON PARA USO EXCLUSIVO DEL PERSONAL DE SERVICIO CAPACITADO. PARA EVITAR EL PELIGRO DE DESCARGÉAS ELÉCTRICAS, NO REALICE NINGÚN SERVICIO A MENOS QUE ESTÉ CAPACITADO PARA HACERIO.

WARTUNG

ANWEISUNGEN FÜR DIE WARTUNG DES GERÄTES GELTEN NUR FÜR GESCHULTES FACHPERSONAL.

ZUR VERMEIDUNG GEFÄHRLICHE, ELEKTRISCHE SCHOCKS, SIND WARTUNGSARBEITEN AUSSCHLIEßLICH VON QUALIFIZIERTEM SERVICEPERSONAL DURCHZUFÜHREN.

ENTRETIEN

L'EMPLOI DES INSTRUCTIONS D'ENTRETIEN DOIT ÊTRE RÉSERVÉ AU PERSONNEL FORMÉ AUX OPÉRATIONS D'ENTRETIEN. POUR PRÉVENIR UN CHOC ÉLECTRIQUE DANGEREUX, NE PAS EFFECTUER D'ENTRETIEN SI L'ON N'A PAS ÉTÉ QUALIFIÉ POUR CE FAIRE.

ASSISTENZA TECNICA

LE ISTRUZIONI RELATIVE ALL'ASSISTENZA SONO PREVISTE ESCLUSIVAMENTE PER IL PERSONALE OPPORTUNAMENTE ADDESTRATO. PER EVITARE PERICOLOSE SCOSSE ELETTRICHE NON EFFETTUARRE ALCUNA RIPARAZIONE A MENO CHE QUALIFICATI A FARLA.



RF VOLTAGE MAY BE PRESENT IN RF ELEMENT SOCKET - KEEP ELEMENT IN SOCKET DURING OPERATION.

DE LA TENSION H.F. PEAT ÊTRE PRÉSENTE DANS LA PRISE DE L'ÉLÉMENT H.F. - CONSERVER L'ÉLÉMENT DANS LA PRISE LORS DE L'EMPLOI.

HF-SPANNUNG KANN IN DER HF-ELEMENT-BUCHSE ANSTEHEN - ELEMENT WÄHREND DES BETRIEBS EINGESTÖPSELT LASSEN.

PUEDE HABER VOLTAJE RF EN EL ENCHUFE DEL ELEMENTO RF - MANTENGA EL ELEMENTO EN EL ENCHUFE DURANTE LA OPERACION.

IL PORTAELEMENTO RF PUÒ PRESENTARE VOLTAGGIO RF - TENERE L'ELEMENTO NELLA PRESA DURANTE IL FUNZIONAMENTO.

About This Manual

This manual is intended for use by operators of the Bird BPM Digital Display Model 3129 and the Bird Broadcast Power Monitor (BPM) Models listed below. It is arranged so that essential safety information is contained in the front of the book. Reading the Safety Precautions Section before operating the equipment is strongly advised. The rest of the manual is divided into Chapters and Sections. A general overview at the beginning of each chapter describes its contents.

B	B	B	B
P	P	P	P
M	M	M	M
7	1	1	1
		U	U
			F
B	B	B	B
P	P	P	P
M	M	M	M
3	3	3	4
	U	U	D
		F	
B	B	B	B
P	P	P	P
M	M	M	M
4	4	6	6
M	M		U
	U		

Chapter Layout

Introduction — Identifies the parts and functions of the BPM and the BPM Display Panel, and optional equipment available.

Theory of Operation — Describes the theory and features of the BPM and the BPM Display, including the alarm options.

Installation — Provides information on installing the BPM and BPM Display at a site, as well as detailed information on the cable connections and installation instructions for the PCTool software.

Operating Instructions — Explains computer commands for controlling the BPM. Describes operation of the BPM Display and use of the PCTool software.

Maintenance — Lists simple routine maintenance tasks for the BPM and BPM Display, as well as troubleshooting information for common problems. Specifications and parts lists are also included.

Changes to This Manual

We have made every effort to ensure this manual is accurate. If you should discover any errors, or if you have suggestions for improving the manual, please send your comments to our Solon, Ohio factory. This manual may be periodically updated. When inquiring about

updates to the manual refer to the part number and revision on the title page.

Table of Contents

Safety Precautions	i
About This Manual	vi
Introduction	1
Broadcast Power Monitor	1
Features	1
Items Supplied	1
Optional Items Available	1
BPM Display	2
Features	2
Component Description	3
Theory of Operation	7
Power Readings	7
Alarm Response	7
Alarm Reset	7
Alarm Latching	7
VSWR Alarm	7
Alarm on Zero Power	8
High Power Alarm	8
Low Power Alarm	8
Installation	9
Unpacking and Inspection	9
Mounting	9
BPM Connections	10
Without Display	10
With Display	10
RS-232 Connector	10
Power/Alarm Connector	11
BPM Display Connections	12
AC Power Connector	12
Remote Computer Connector	12
Connecting RF Power	12
RF Direction	12
“QC” Connector	13

Swivel Flanged Connector	13
Unflanged Connector	13
RS-232 Port Setup	14
PCTool Installation	14
Computer Requirements	14
Operating Instructions	15
Warmup	15
Elements	15
BPM Controls	15
PCTool Software	16
Main Screen	16
Com Settings	17
Alarm Options	17
Terminal Commands	20
“T”	20
“C”	20
“A”	20
BPM Display	21
Power On	21
Mode Button	21
Units Button	21
Reset Button	21
Alarm LED	21
Maintenance	23
Inspection and Cleaning	23
Troubleshooting	23
BPM Display Fuses	24
Customer Service	25
Replacement Parts	25
Specifications	26
Line Sections	29

This chapter contains introductory information including items supplied, component description, and specifications.

Broadcast Power Monitor

The Bird Broadcast Power Monitor (BPM) is a compact, microprocessor controlled instrument intended for long-term system VSWR and power monitoring. See Figure 10 on page 29 for an outline drawing and dimensions.

- | | |
|---------------------------------|---|
| Features | <ul style="list-style-type: none">• Compatible with analog or digital systems• Monitors VSWR and power• Measures forward and reflected power ranges from 50 W up to 150 kW• Remote monitoring capability• Multiple alarm options• May be used at any point in the feeder line between the combiner and antenna• Available in a variety of line sections |
| Items Supplied | <ul style="list-style-type: none">• Broadcast Power Monitor• Instruction Manual |
| Optional Items Available | <p>BPM Display: Displays the BPM status and acts as a dc power supply. Includes a power cord and 50 foot, 9 pin and 15 pin cables. See “BPM Display” on page 2 for more details.</p> <p>PCTool Software: PC software for data display, alarm monitoring, and setting alarm options. Comes with 10 foot, 9 pin interface cable.</p> |

DB-15 Power/Alarm Cables: Connects the BPM to a power supply and to external controllers. 50 feet long with male/female connectors. Refer to Figure 4 on page 11 for pin layout.

DB-15 Interface Connector: Allows easy custom data cable connections to the BPM.

DB-15 Surge Protector: Surge protector for DB-15 Power/Alarm connector.

9 pin RS-232 PC Interface Cables: Connects the BPM to a PC. Available in either 10 or 50 foot lengths, with male/female connectors. Refer to Figure 3 on page 10 for pin layout.

BPM Display

The Bird 3129 BPM Digital Display (BPM Display) is a remote monitor panel to be used with the BPM.

Features

- A single line display divided into two fields. Displays forward power, and either reflected power or the match measurement. An indicator in the lower right of the last digit blinks on and off to indicate communication with the BPM.
- Displays match measurements as VSWR, Rho, Return Loss, or efficiency
- Supplies dc power to the BPM
- Displays the BPM alarm status
- Provides an electrical interface for the discrete outputs from the BPM
- Provides an interface to connect a PC to the BPM

Component Description

Figure 1
Broadcast
Power
Monitor
Components

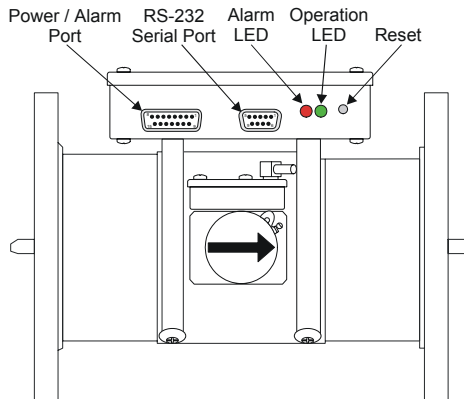
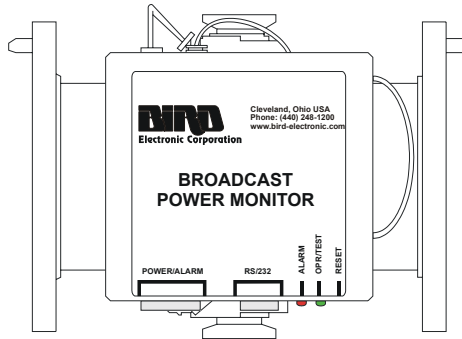

Reset Switch	Press to reset the alarm. If an alarm trigger is still present, the alarm will reactivate
Operation/Test LED	Green LED, lights when the unit is powered
Alarm LED	Red LED, lights when an alarm is triggered
RS-232 Serial Port	Interface with a PC or display panel using a 9 pin RS-232 cable
Power/Alarm Parallel Port	Connects to the power supply using a 15 pin cable. Also used for remote operation.

Figure 2
BPM Display Components

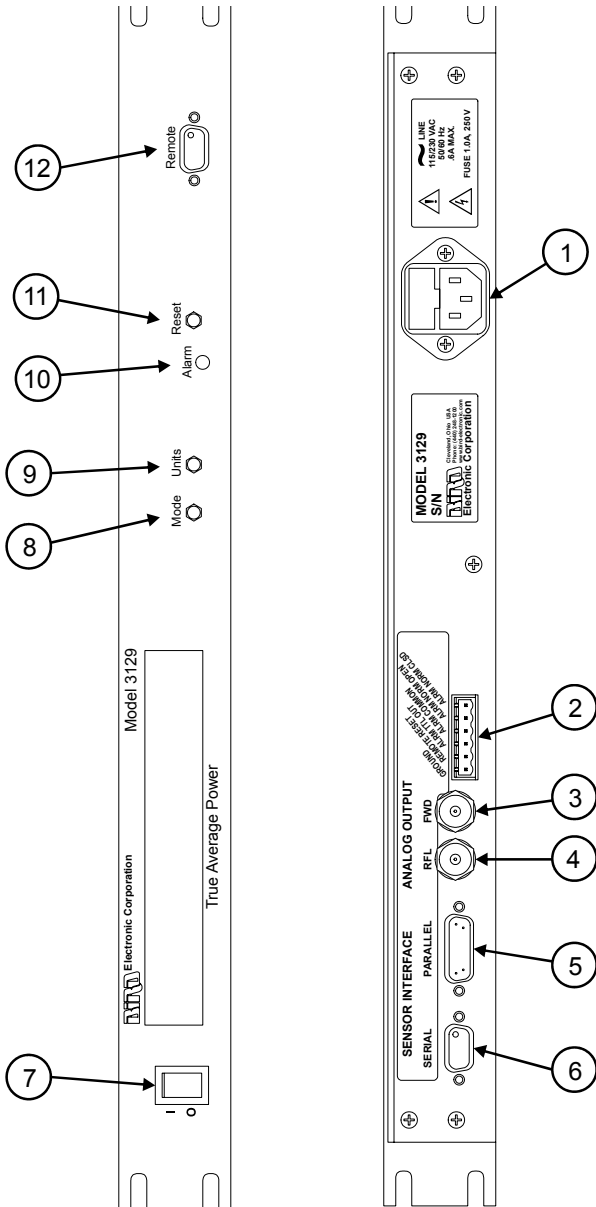

Item (Fig. 2)	Function	Description
1	AC Power Connector	Connect to ac power supply with a power cord
2	Alarm Interlocks	Alarm interlocks are used to shut down transmitter when an alarm condition occurs. Remote reset can be used to reset the BPM-E after the alarm event
3	Analog Output, Forward Power	0 to 2 V full scale, linear, 200 ohm output impedance, BNC (f) connector
4	Analog Output, Reflected Power	0 to 2 V full scale, linear, 200 ohm output impedance, BNC (f) connector
5	Power/ Alarm Port	Connects to the BPM-E using a 15 pin cable. Provides operating power to the BPM-E. Contains analog and digital alarm information.
6	RS-232 Serial Port	Connects to the BPM-E using a 9 pin RS-232 cable (ASCII data between the BPM-E and the display)
7	AC Power Switch	Turns on the display panel (and BPM-E if connected).
8	Mode Button	Selects display mode for the right field.
9	Units Button	Selects the displayed power units.
10	Alarm LED	Red LED, lights when an alarm is triggered
11	Reset Switch	Press to reset the alarm. If an alarm trigger is still present, the alarm will reactivate
12	Remote Computer Connector	Interface with a PC using a 9 pin RS-232 cable

Power Readings The BPM has a dynamic range of 13 dB. The maximum safe power is listed on each element. The minimum power for accurate readings is 13 dB below that. For example, a BPM equipped with a BPM3-1KB element (1,000 W or 60 dBm max.) has a minimum power of $60 - 13 = 47$ dBm or 50 W.

Alarm Response When an alarm is triggered, the Bird Broadcast Power Monitor turns on the alarm LED and activates a Form C dry contact relay.

The alarm relay defaults to fail/safe. That is, the alarm activates when the relay is not energized or power is lost. However, the PCTool software can configure the alarm to either energize or de-energize in response to an alarm.

Alarm Reset

- Alarms can be reset locally with the reset switch on the BPM or on the BPM display.
- Alarms are reset when the reset pin on the Power/Alarm port is activated by a TTL compatible logic low signal (0 to 0.8 Vdc).
- The PCTool can reset the unit through the RS-232 port by sending a “Reset Alarm” command.

Alarm Latching The alarm defaults to latching operation. In this mode, the alarm will stay active until reset. In non-latching mode, the alarm will reset automatically about forty seconds after the trigger condition is corrected.

VSWR Alarm The BPM continuously monitors forward and reflected power. From the power measurements, the VSWR is calculated and compared to the allowed maximum (default of 1.8 to 1). Based on the results of the comparison, possible actions include:

- No alarms are activated if the VSWR is less than the maximum, or if the VSWR alarm is disabled.
- If the VSWR is equal to or slightly greater than the maximum, additional measurements are accumulated to determine a trend. If reverse power is increasing, an alarm is triggered. If the reverse power is stable, measurements continue until a trend is established. An alarm will be set if the VSWR exceeds the maximum for more than thirty seconds.
- If the VSWR is much greater than the maximum then an alarm is triggered immediately.

**Alarm on
Zero Power**

When the forward power is very small (< 2.5% of full scale), the measured VSWR becomes large due to the noise floor of the sensor. Under these conditions, the VSWR level is meaningless. When the zero power alarm is disabled, the VSWR will not be monitored at these low powers.

**High Power
Alarm**

When the high power alarm is enabled, the forward power is continuously monitored. The alarm trigger is a percentage of the Monitor's full scale power, from 0 – 125%. If the forward power is greater than the trigger level, an alarm is triggered.

**Low Power
Alarm**

When the low power alarm is enabled, the forward power is continuously monitored. The alarm trigger is a percentage of the Monitor's full scale power, from 0 – 125%. If the forward power is less than the trigger level, an alarm is triggered.

This chapter provides information for preparing the Bird Broadcast Power Monitor for use.

Unpacking and Inspection

1. Carefully inspect the shipping container for signs of damage. If damage is noticed, do not unpack the unit. Immediately notify the shipping carrier and Bird Electronic Corporation.
2. If the shipping container is not damaged, unpack the unit. Save the packing material in case the unit needs to be shipped again.
3. Inspect all of the components for visible signs of damage. Immediately notify the shipping carrier and Bird Electronic Corporation of equipment damage or missing parts.

The Bird BPM is shipped complete and ready for use upon receipt. After unpacking and inspecting the unit, it is ready to be installed.

WARNING

Leaking RF energy is a potential health hazard. Never attempt to connect or disconnect equipment from the transmission line while RF power is being applied. Severe burns, electrical shock, or death can occur.

Mounting

Do not use the BPM in areas of condensing humidity.

Mount the BPM in the feeder line between the transmitter and the antenna. See “Connecting RF Power” on page 12 for instructions on connecting the RF line. Make sure that the alarm LED and reset button are accessible, and that the connecting cables have proper clearance.

Put the BPM Display in a standard (1U) rack mount.

BPM Connections

BPM connections required depend on the intended use:

Without Display

- Connect the Power/Alarm connector to a dc supply.
- Connect the RS-232 connector to a PC if remote operation is desired.

With Display

- Connect the Power/Alarm connector to the display's Power/Alarm port.
- Connect the RS-232 connector to the display's RS-232 port.

RS-232 Connector

The RS-232 connector carries ASCII data between the BPM and a display panel, a PC, or a PC connected to the display's front panel. Pin numbers and descriptions are given in Figure 3.

Figure 3
DB-9
RS-232
Connector

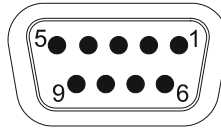

Pin	Description
1	Carrier Detect, always > +5 Vdc
2	Transmit Output, RS-232 data signal
3	Receive Input, RS-232 data signal
4	Data Set Ready Input, connected but not used
5	Data Signal Ground
6	Data Terminal Ready Output, connected but not used
7	Clear-To-Send, shorted internally to Ready-To-Send
8	Ready-To-Send, shorted internally to Clear-To-Send
9	Ring Indicator, no connection

**Power/
Alarm
Connector**

The Power/Alarm connector provides operating power and sends analog output to external display panels. Pin numbers and descriptions are given in Figure 4.

The BPM requires a +12 to +26 Vdc (+15 V nominal) @ 0.1 A power supply.

Figure 4
DB-15
*Power/
Alarm
Connector*

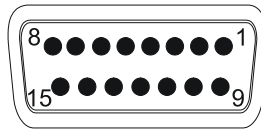

Pin	Description
1	Relay, normally closed contact (closed when relay is not energized) (open when there is no alarm)
2	Relay, common contact
3	TTL compatible alarm, 0 to ≥ 4.0 Vdc with a 10k load when the alarm is active
4	Forward monitor, 0 to 2 Vdc full scale
5	TTL compatible reset, 0 to +0.8 Vdc resets alarm
6-7	Internal connection
8	Reverse monitor, 0 to 2 Vdc full scale
9	Relay, normally open contact (open when relay is not energized) (closed when there is no alarm)
10-11	Internal connection
12-13	DC input, +12 to +26 Vdc
14-15	DC input and signal ground

BPM Display Connections

CAUTION

The 3129 parallel port should only be used to power the BPM.
Do not connect anything else to the 3129.

AC Power Connector

The AC Power connector provides operating power for the BPM Display and the BPM. The ac power supply cord is the disconnect device for this product. Any approved power cord, either domestic type SVT, 300 Vac, 18 AWG, 10 A, 3 conductor (including ground) or international type H05VV-F, 300 Vac, 1.00 mm, 10 A, 3 conductor (including ground) may be used.

Remote Computer Connector

Connect the display's Remote Computer connector to a PC if remote operation is desired. When a PC is connected, signals are routed directly from the BPM RS-232 connector to the PC.

Connecting RF Power

The RF transmission line can be attached using standard coaxial line coupling kits.

WARNING

Leaking RF energy is a potential health hazard. Never attempt to connect or disconnect equipment from the transmission line while RF power is being applied. Severe burns, electrical shock, or death can occur.

RF Direction

There are two elements in the BPM. The Forward Element is the element with the higher power. Connect the BPM to the RF line so that the arrow on the Forward Element is pointing in the direction of power flow; i.e., from transmitter to antenna

Figure 5
BPM
Direction

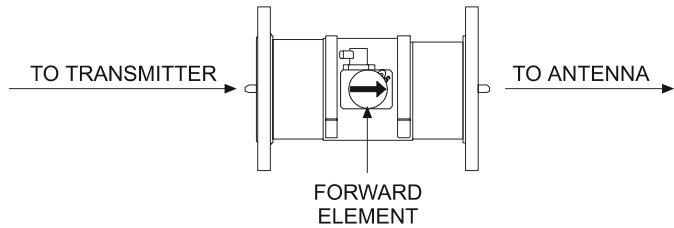

**“QC”
Connector**

Use 50 ohm coaxial cable such as RG-218/U or -220/U (-17A or -19A), appropriate for the frequency and power level of operation. Use a cable connector which will mate with the one on the BPM7.

**Swivel
Flanged
Connector**

To couple the swivel flange with a flanged RF transmission line, use an appropriate coupling kit.

- Insert the center bullet and push it in until it is fully seated.
- Connect the coaxial input in a straight line and push carefully on the center conductor to close.

 **NOTE:** The swivel flange on the load makes connection independent of the orientation of the fixed flange on the coaxial input outer conductor.

- Insert the bolt sets and tighten evenly all around to transmission line manufacturer’s recommended torque. Use all of the bolts.

**Unflanged
Connector**

To couple the unflanged connector with an unflanged RF line, use an appropriate coupling kit.

- Insert the center bullet and bottom it on the midpoint nibs.
- Position the outer sleeve, with clamping bands, over the input connector.
- Set the transmission line snugly against the coupling stops.
- Position the clamping bands evenly about 3/4” from the ends of the sleeve.
- Tighten the clamping bands.

RS-232 Port Setup

The RS-232 port is configured for 9600 baud, 8 data bits, 1 stop bit and no parity. This configuration is fixed in the firmware and cannot be modified. Operate the serial interface as follows:

- Connect the BPM or BPM Display to the computer's serial port with a DB-9 cable. *Do not use a null modem adapter.* The port is configurable from within the PCTool software.
- To use the Bird PCTool software, install it on the computer and start the application. Refer to "PCTool Software" on page 16 for information about using the program.
- To use a terminal program, configure it for 9600 baud, 8 data bits, 1 stop bit, no parity, and no handshake. Set the preferences so that echo is off and line feeds are not appended to output transmission. The commands available are detailed in "Terminal Commands" on page 20.

PCTool Installation

Computer Requirements

The Bird PCTool software will run on any computer running Windows NT or Windows 95/98/2000. To install and run the program, your computer system must meet or exceed the requirements listed below:

486 or better CPU (66 MHz or better recommended)
1 MB of free memory
Hard Disk Drive
CD-ROM Drive

Follow the instructions on the CD provided to install the software.

A description of all controls and indicators on the BPM, BPM Display, and PCTool is provided in this chapter. Read and become familiar with the following instructions before operating the unit.

- Warmup** For best results, allow the Bird Broadcast Power Monitor to stabilize for at least one hour after initially applying RF power, and for at least thirty minutes when adjusting power levels.
- Elements** BPM elements and line sections are carefully selected for accuracy. Use of BPM elements other than the ones on this unit may cause measurement errors. Do not remove the elements.
- BPM Controls** There are two indicators and one control on the BPM:
- Operation/Test LED:** Lights when the unit is powered.
 - Alarm LED:** Lights when an alarm has been triggered.
 - Reset Switch:** Press to reset an alarm. If the alarm trigger condition is still present, the alarm will reactivate.

PCTool Software

Main Screen

The PCTool communicates with and configures the remote BPM. It displays forward and reverse power along with VSWR, return loss, match efficiency and transmitted power. Figure 6 shows a sample of the display screen. Refer to the software “Help” file for specific instructions.

Figure 6
Sample
Display

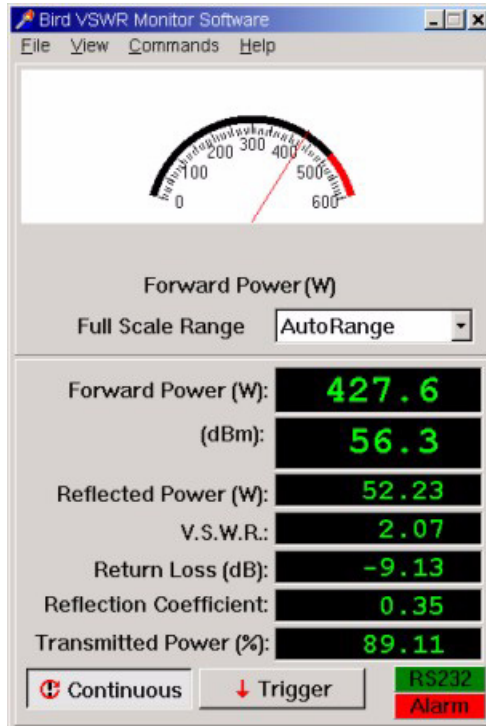

The main screen has two buttons at the bottom, “Trigger” and “Continuous”. Clicking on these will trigger readings. “Trigger” will display a single reading, while “Continuous” will take a new reading every second.

Com Settings

The PCTool software must be set to use the correct Com Port to communicate with the Antenna Monitor. The default is Com Port 1. To change the Com Port, select the correct one from the “View>Comm Port” menu, shown in Figure 7 below.

Figure 7
Com Menu



Alarm Options

Three alarms can be configured from the software. All alarms are configured from the “View>Options” menu, shown in Figure 8 below.

- High VSWR: Calculated VSWR exceeds a setpoint.
- High Fwd Power: Measured power exceeds a setpoint.
- Low Forward Power: Measured power is less than a setpoint.

 **NOTE:** Some models are not equipped with all alarm variations.

Master Alarm Enable: allows the alarms to work. When this checkbox is *unchecked*, all alarms will be disabled. When it is *checked*, the VSWR alarm will automatically be enabled while “Alarm on Zero Power”, “High Power Alarm”, and “Low Power Alarm” will be on or off depending on their checkboxes.

Relay Energized on Alarm: The energized state of the relay can be set. When this checkbox is *unchecked*, the relay will be de-energized when an alarm is detected and energized when there is no alarm. With this setting, the alarm is fail-safe. When it is *checked*, the relay will be energized when an alarm is detected and de-energized when there is no alarm.

Figure 8
Options
Menu

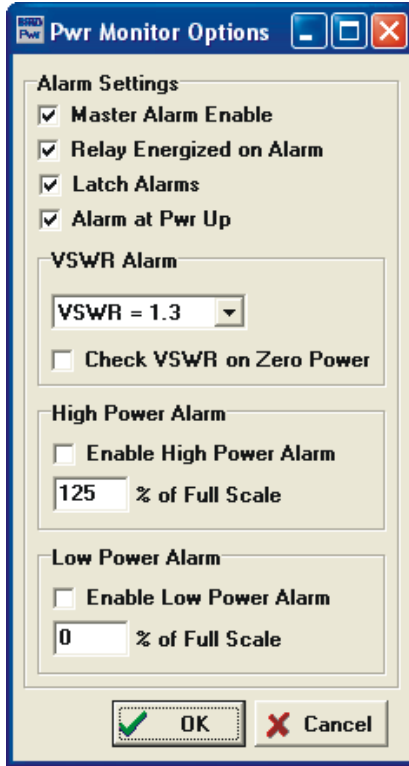

Latch Alarms: Sets whether the alarm will reset automatically in the absence of an alarm condition. When this checkbox is *unchecked*, if an alarm trigger is corrected the alarm will reset after a forty second delay. When it is *checked*, the alarm must be manually reset.

Alarm at Power (Pwr) Up: At power up, before the instrument is ready to take measurements, the microcontroller resets the circuitry to the default condition and then performs internal initialization tasks (such as memory test, hardware setup, and reading EEPROM parameters). *Check* the Alarm at Pwr Up box to have the alarm relay set (enabled) during the microcontroller initialization time. This is

the default setting. *Uncheck* the Alarm at Pwr Up box to disable the alarm during the microcontroller initialization time.

 NOTE: When the Alarm at Pwr Up feature is disabled, the alarm relay may set for a few milliseconds during initialization. To avoid this, install the circuit shown below.

VSWR Alarm: adjustable from 1.3 to 2.5 by increments of 0.1. To allow the VSWR alarm to trigger even at low forward power (< 2.5% of full scale power), check the “Alarm on Zero Power” checkbox.

While the VSWR trip point can now be set to 2.5, the instrument cannot always measure VSWR above 1.9. This is due to the large amount of reflected power caused at higher VSWRs. The maximum VSWR that can be physically measured is determined by the ratio of the forward and reflected detectors at full scale. This ratio is 10:1. The maximum measurable VSWR occurs when the reflected channel is near its limit. The following table shows the maximum possible VSWR measurement as a function of percentage of full scale forward input power. Use this table as a guide to determine the VSWR trip point.

Percentage Full Scale	Max VSWR
50%	3.00
55%	2.82
60%	2.68
65%	2.56
70%	2.46
75%	2.38
80%	2.31
85%	2.24
90%	2.19
95%	2.14
100%	2.09

High Power Alarm: adjustable from 0 to 125% of the BPM's full scale power. The alarm setpoint is entered as the % of full scale. For example, if you have a 500W full scale unit and would like an alarm when the forward power exceeds 375 W, the alarm setpoint would be $375/500 \times 100$ or 75%. Enter "75" in the field and check the "Enable High Power Alarm" checkbox.

Low Power Alarm: set in the same way as the High Power Alarm, however this alarm will trigger when the forward power is *less than* the alarm setpoint.

Terminal Commands

There are two commands which can be sent when the BPM is connected to a terminal.

"T" The "T" command will cause the unit to echo a single measurement. The format is:

```
nnn.n,nn.nnAB<CR><LF>
```

That is, three digits of forward power, a decimal point, a fourth digit of forward power, a comma, followed by two digits of reverse power, a decimal point, and two digits of reverse power.

The first character following will be "A" if an alarm has been triggered until the alarm is reset, and will be blank if there is no alarm. The second character will be "0" if "Alarm on Zero Power" is disabled, and "1" if "Alarm on Zero Power" is enabled.

"C" The "C" command will cause the unit to echo measurements repeatedly. The format is identical to the "T" command. The "C" command can be interrupted at any time by sending the "T" command.

"A" The "A" command will reset the alarm. If an alarm condition is still present, the alarm will turn back on after being reset.

BPM Display

Power On After the AC power switch is set to ON, a message will be displayed. Examples of possible messages are:

- 'BPM Display ver x.xxx' Shown at power-up for about 4 seconds.
- 'Waiting...' Shown when no response is received from the BPM through the RS-232 Serial Port.
- 'Serial Pass Thru...' Shown when a PC or other remote device is connected to the Remote Computer Connector on the front panel.

Mode Button Press MODE to cycle through the possible display modes for the right half of the display, which are:

- Reflected Power
- Match Efficiency (%)
- Return Loss (dB)
- VSWR (SWR)
- Reflection Coefficient (ρ)

Units Button Press UNITS to toggle the display between Watts (W or kW) and dBm. The unit applies to forward power and to reflected power (if it is displayed).

Reset Button Directly connected to the Alarm Reset pin of the BPM Power/Alarm connector.

Alarm LED Directly connected to the Alarm pin on the BPM Power/Alarm connector.

Chapter 5

Maintenance

This chapter contains cleaning, troubleshooting, specifications, and part information for the Bird Broadcast Power Monitor and BPM Display.

Inspection and Cleaning

This unit requires only simple and routine maintenance.

CAUTION

Do not use harsh or abrasive detergents for cleaning.

WARNING

Disconnect the unit from the RF power source and the ac line before any disassembly. The potential for electrical shock exists.

1. Wipe off dust and dirt regularly. Use a soft, clean cloth dampened with mild detergent.
2. Check connectors, connector pins, and cables for damage. If needed, clean the connectors using a self-drying contact cleaner that leaves no residue.

Troubleshooting

The Bird Broadcast Power Monitor has no operator serviceable parts. Any required service must be performed at an authorized service facility.

The table below contains troubleshooting information for problems which can occur during normal operation. This manual cannot list all malfunctions that may occur, or their corrective actions. If a problem is not listed or is not corrected by the listed actions, notify a qualified service center.

PROBLEM	POSSIBLE CAUSE	CORRECTION
Operation/Test LED does not illuminate	No dc power	Check power source
	Defective LED	Return the unit to an authorized service center
Alarm LED does not illuminate	Defective LED	Return the unit to an authorized service center
High VSWR	Dirty connectors	Clean connectors
	Defective connectors	Replace connectors
	Shorted or open transmission line	Have the line serviced.
BPM Display screen does not light	Unit is not turned on	Set AC Power Switch to ON
	Unit is not plugged in	Connect ac power cord
	Fuse is blown	Replace fuse

BPM Display Fuses

The BPM Display contains two time-delayed IEC (5 x 20mm) Type T 1.0A, 250V fuses. These are the only user replaceable parts. Refer to figure Figure 9 for fuse location.

Figure 9
Fuse
Location

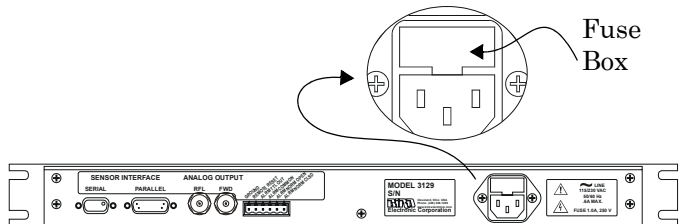

Customer Service

Any maintenance or service procedure beyond the scope of those provided in this chapter should be referred to a qualified service center.

If you need to return the unit for any reason, contact the Bird Service Center for a return authorization. All instruments returned must be shipped prepaid and to the attention of Bird Service Center.

Bird Service Center

30303 Aurora Road
Cleveland (Solon), Ohio 44139-2794
Phone: +1 440 519-2298
Fax: +1 440 519-2326
E-mail: bsc@bird-technologies.com

For the location of the sales office nearest you, give us a call or visit our Web site at:

<http://www.bird-electronic.com>

Replacement Parts

DESCRIPTION	Part Number
BPM Display	3129
PCTool Software	7005A970
9 pin RS-232 Interface Cable	
50 ft.	5A2264-09-MF-50
10 ft.	5A2264-09-MF-10
DB-15 Interface Cable, 50 ft., male/female	5A2264-15-MF-50
DB-15 Interface Connector	SUBCON-15/M-SH

Specifications

Broadcast Power Monitor (BPM)

Frequency Range*	50 – 125 MHz 100 – 250 MHz 400 – 1000 MHz
RF Power Rating*	
Forward	50 W to 150 kW
Reflected	5 W to 15 kW
Dynamic Range	13 dB
Measurement Type	In-line, true average power
Peak/Average Ratio	10 dB max.
Coupler Directivity	> 25 dB
Settling Time	< 1 second
Insertion VSWR	1.05:1 max.
Impedance	50 ohms
Accuracy, Power	± 5% of reading [†]
Accuracy, VSWR	± 10% of reading [†]
Element Type	Designed to use BPM series elements
Connectors, RF	See “Line Sections” on page 29
RS-232 Serial Port	
Connector	Female DB-9
Protocol	RS-232, 9600 baud, no parity, 8 data bits, 1 stop bit, no handshake
Power/Alarm Parallel Port	Female DB-15 connector
Alarm Relay	Dry form C, relay contacts, common normally open, normally closed
Relay Contact Rating	100 Vdc @ 0.5 A
Analog Outputs	0 to 2 V full scale, 200 ohm output impedance
DC Power Required	+13.8 to +28 Vdc @ 0.1 A

Temperature

Operating	-10 to +50 °C (+14 to 122 °F)
Storage	-40 to +80 °C (-40 to +176 °F)

Humidity 95% max. (non-condensing)

Altitude 3000 m (10,000 ft.)

Calibration Cycle > 1 year

Recommended Calibration Cycle Interval User defined

Dimensions See "Line Sections" on page 29

Weight, Nominal See "Line Sections" on page 29

- * Element dependent. BPM element lists frequency range and max. power
- † 1 hour after initially applying power, or 30 min. after changing power level. Power accuracy is valid only within the dynamic range of the element being used. For example, a 1000W element with a 13 dB dynamic range will be accurate from 1000W down to 50W (50W is 13dB down from 1000W). A 6000W element with a 13dB dynamic range would be accurate from 6000W down to 300W (300W is 13dB down from 6000W).

BPM Digital Display

Display 20 character LCD with LED backlight

RS-232 Serial Port

Connector	Male DB-9
Protocol	RS-232, 9600 baud, no parity, 8 data bits, 1 stop bit, no handshake

Power/Alarm Parallel Port Male DB-15 connector

Remote Computer Connector

Connector	Female DB-9
Protocol	RS-232, 9600 baud, no parity, 8 data bits, 1 stop bit, no handshake

AC Power Requirements 115/230 Vac @ 50/60 Hz, 0.6 A

AC Connector	North American Power Cord Standard
Domestic	Type SVT, 300 Vac, 18 AWG, 10 A, 3 conductor (including ground)
International	Type H05VV-F, 300 Vac, 1.00 mm, 10 A, 3 conductor (including ground)
Temperature	
Operating	-10 to +50 °C (+14 to 122 °F)
Storage	-40 to +80 °C (-40 to +176 °F)
Humidity	95% max. (non-condensing)
Altitude	3000 m (10,000 ft.)
Dimensions	19"L x 1.75"W X 5"H (483 x 44 x 127 mm) (1U EIA)
Weight, Nominal	< 10 lbs

PCTool Software

Forward Power	1 W to 150.0 kW full scale
Reverse Power	100 mW to 15.0 kW full scale
VSWR	1.00 to 99.9
Return Loss	0.0 to -99.9
Match Efficiency	0.0 to 100.0%
PC Port Required	
Connector	Male DB-9
Protocol	RS-232, 9600 baud, no parity, 8 data bits, 1 stop bit, no handshake

Line Sections

Figure 10
Broadcast
Power
Monitor
Dimensions

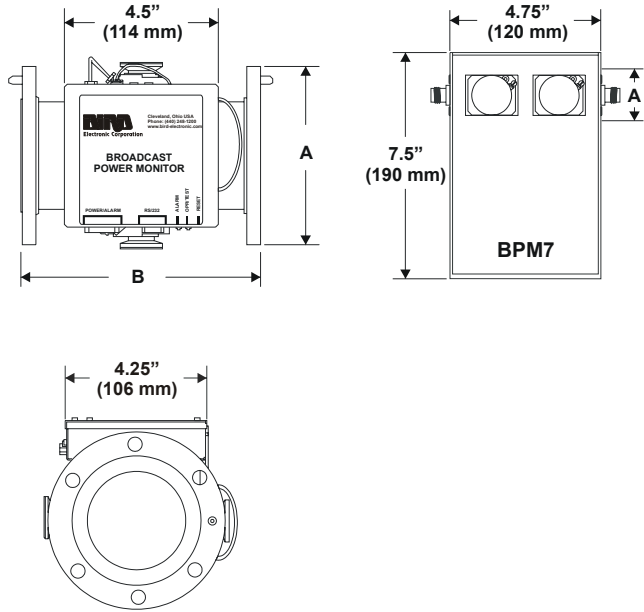

Model	Connector	Dim. A	Dim. B	Inner Conductor Setback	Weight
BPM1	1-5/8" EIA Flanged	3.50" (89 mm)	6.75" (171.5 mm)	EIA	3.25 lbs. (1.5 kg)
BPM1U	1-5/8" EIA Unflanged	1-5/8" (41.3 mm)	6.38" (162 mm)	0.438" (11.1 mm)	1.5 lbs. (0.68 kg)
BPM1UF	1-5/8" EIA Unflanged, Flush Center	1-5/8" (41.28 mm)	6.38" (162 mm)	0	1.5 lbs. (0.68 kg)
BPM3	3-1/8" EIA Flanged	5.19" (132 mm)	7.03" (178.6 mm)	EIA	7.25 lbs. (3.3 kg)
BPM3U	3-1/8" EIA Unflanged	3-1/8" (79.4 mm)	6.5" (165.1 mm)	0.688" (17.5 mm)	4.25 lbs. (1.93 kg)
BPM3UF	3-1/8" EIA Unflanged, Flush Center	3-1/8" (79.4 mm)	6.5" (165.1 mm)	0	4.25 lbs. (1.93 kg)
BPM4D	4-1/16" Flanged, Dielectric Standard	6.19" (157 mm)	8.38" (212.8 mm)	1.22" (31 mm)	8.88 lbs. (4 kg)

Model	Connector	Dim. A	Dim. B	Inner Conductor Setback	Weight
BPM4M	4-1/16" Flanged, Myat Standard	6.19" (157 mm)	8.38" (212.8 mm)	1.375" (35 mm)	8.88 lbs. (4 kg)
BPM4MU	4-1/16" Unflanged, Myat Standard	4-1/16" (103.2 mm)	7.5" (190.5 mm)	1.375" (35 mm)	2.88 lbs. (1.3 kg)
BPM6	6-1/8" EIA Flanged	8.13" (206 mm)	10.22" (259.6 mm)	EIA	17 lbs. (4 kg)
BPM6U	6-1/8" EIA Unflanged	6-1/8" (155.6 mm)	9.63" (244.6 mm)	0.968" (24.6 mm)	12.75 lbs. (5.78 kg)
BPM7	7/8" line, Type N connectors	1.25" (318 mm)	n/a	n/a	1.25 lbs. (0.57 kg)

Limited Warranty

All products manufactured by Seller are warranted to be free from defects in material and workmanship for a period of one (1) year, unless otherwise specified, from date of shipment and to conform to applicable specifications, drawings, blueprints and/or samples. Seller's sole obligation under these warranties shall be to issue credit, repair or replace any item or part thereof which is proved to be other than as warranted; no allowance shall be made for any labor charges of Buyer for replacement of parts, adjustment or repairs, or any other work, unless such charges are authorized in advance by Seller.

If Seller's products are claimed to be defective in material or workmanship or not to conform to specifications, drawings, blueprints and/or samples, Seller shall, upon prompt notice thereof, either examine the products where they are located or issue shipping instructions for return to Seller (transportation-charges prepaid by Buyer). In the event any of our products are proved to be other than as warranted, transportation costs (cheapest way) to and from Seller's plant, will be borne by Seller and reimbursement or credit will be made for amounts so expended by Buyer. Every such claim for breach of these warranties shall be deemed to be waived by Buyer unless made in writing within ten (10) days from the date of discovery of the defect.

The above warranties shall not extend to any products or parts thereof which have been subjected to any misuse or neglect, damaged by accident, rendered defective by reason of improper installation or by the performance of repairs or alterations outside of our plant, and shall not apply to any goods or parts thereof furnished by Buyer or acquired from others at Buyer's request and/or to Buyer's specifications. Routine (regularly required) calibration is not covered under this limited warranty. In addition, Seller's warranties do not extend to the failure of tubes, transistors, fuses and batteries, or to other equipment and parts manufactured by others except to the extent of the original manufacturer's warranty to Seller.

The obligations under the foregoing warranties are limited to the precise terms thereof. These warranties provide exclusive remedies, expressly in lieu of all other remedies including claims for special or consequential damages. SELLER NEITHER MAKES NOR ASSUMES ANY OTHER WARRANTY WHATSOEVER, WHETHER EXPRESS, STATUTORY, OR IMPLIED, INCLUDING WARRANTIES OF MERCHANTABILITY AND FITNESS, AND NO PERSON IS AUTHORIZED TO ASSUME FOR SELLER ANY OBLIGATION OR LIABILITY NOT STRICTLY IN ACCORDANCE WITH THE FOREGOING.

