

**INSTRUCTION  
MANUAL  
FOR**

**Model 944**



**EICO**

**ELECTRONIC  
INSTRUMENT CO., Inc.**

**33-00 NORTHERN BLVD.**

**LONG ISLAND CITY 1, N. Y.**

**EVERYTHING 4 LESS**

**ENJOY YOUR BOOKS**

**PLEASE VISIT OUR STORE FOR EVEN MORE GREAT STUFF!**

**[WWW.EVERYTHING4LESSSTORE.COM](http://WWW.EVERYTHING4LESSSTORE.COM)**

**COPYRIGHT NOTICE**

**ALL MATERIALS INCLUDING CD/DVD AND PDF FILES ARE COPYRIGHTED**

**[WWW.EVERYTHING4LESSSTORE.COM](http://WWW.EVERYTHING4LESSSTORE.COM) VON WALTHOUR PRODUCTIONS AND MAY NOT BE REPRODUCED, COPIED OR RESOLD UNDER ANY CIRCUMSTANCES. YOU MAY HOWEVER MAKE A COPY FOR YOUR OWN PERSONAL BACKUP. MATERIALS ARE FOR PERSONAL USE ONLY.**

**IF YOU PURCHASED THIS FROM ANYWHERE BUT FROM US PLEASE NOTIFY US IMMEDIATELY SO THAT WE MAY CHECK IF YOU PURCHASED FROM AN AUTHORIZED RESELLER SO WE CAN LET YOU KNOW IF YOU NEED TO RETURN FOR FULL REFUND FROM AN UNAUTHORIZED SELLER.**

**THANKS AGAIN AND PLEASE TAKE THE TIME TO VISIT OUR STORE.**

**ATTENTION! EVERYTHING ON SALE NOW!!**



**HOT SALE!**



# INSTRUCTION MANUAL

## Model 944

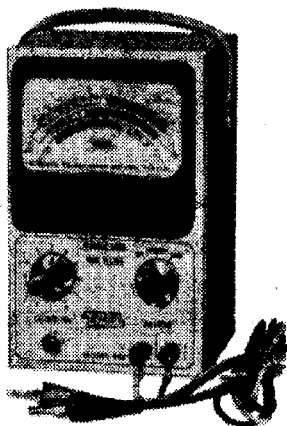

ELECTRONIC INSTRUMENT CO., Inc.

# general description

Operating on the grid-dipmeter principle, the Model 944 Flyback Transformer, & Yoke Tester provides a short test that will reveal even one shorted turn in any TV flyback transformer or yoke. As an open winding will produce the same indication as a perfect winding on the short test, a continuity test is also provided.

The need for this instrument stems from the fact that even one or two shorted turns will absorb the energy normally developed in the magnetic field of a flyback transformer or yoke and make it defective. While this is a very common reason for flyback transformer failure, it has remained a difficult trouble to detect because the slight change of winding resistance due to a few shorted turns is entirely masked by the normal commercial tolerances on winding resistance ( $\pm 20\%$ ). (Ohmmeter measurements are useful only when a winding is open or more than 20% of the turns are shorted.)

As a result actually replacing the flyback transformer with a new one, has been the only reliable way of checking this part. Not only is this a very time-consuming and difficult job, but as a general servicing procedure it requires either stocking a full line of replacements or purchasing a flyback transformer or yoke for a particular receiver without being sure that the transformer or yoke you are replacing is defective and therefore the cause of the trouble.

The Model 944 is not only expressly designed to deal with this problem completely and effectively, but to provide maximum ease of operation. All readings are made on a large 4 1/2", 50  $\mu$ a meter with three separate "GOOD-BAD" scales for flyback transformer, yoke, and continuity testing. In addition, separate calibration points are provided on the meter scale for air core and iron core flybacks so that all types may be tested accurately with no extra operation required (such as inserting an iron core into an air core type flyback to boost the inductance). Entirely professional in both appearance and performance, yet extremely compact for easy portability, the Model 944 is a wise and necessary addition to any TV serviceman's equipment.

## specifications

### Electrical Specifications:

Oscillator Frequency ..... approx. 600 cps interrupted 60 times per second

Test Voltage ..... 100 rms v (short test); 60 rms v (cont. test)

Tube Complement ..... 6K6

Meter ..... 4 1/2" 50 ua - 2000  $\Omega$

Power Supply ..... transformer operated from 105-125 volts AC,  
50-60 cps line

### Mechanical Specifications

Overall Dimensions ..... 8 1/2" high, 5" wide, 5" deep

Weight ..... 5 pounds

Cabinet ..... steel, rub-proof grey wrinkle finish

Panel ..... aluminum, satin finish, 2 color deep-etched

## **circuit description**

The heart of the Model 944 Flyback Transformer & Yoke Tester is an oscillator circuit employing a 6K6 tube. The secondary winding of transformer T2 and capacitor C1 make up the tank circuit. The primary of transformer T2 functions as a feedback coil through which power taken from the line isolation transformer T1 is delivered to the oscillator. The isolation provided by T1 permits the instrument to be used safely on transformer-less or universal TV sets.

As the oscillator operates only during the positive half-cycles of the raw ac voltage which powers it, oscillation is interrupted 60 times a second to simulate the operating condition of a flyback transformer under pulsed conditions. This is desirable also because the abrupt potential changes across the winding under test will often expose an intermittent condition which might otherwise go undetected.

The frequency of oscillation is approximately 600 cps (with nothing connected across the test terminals) as determined by the secondary of T2, C1, and the time constant of R1 and C2. When the oscillator circuit is operating, a negative voltage (bias) is developed on the grid of the tube which is measured by a 50 ua meter. The meter sensitivity can be adjusted by rheostat R3 (CALIBRATION control) in series with the meter and mounted on the front panel.

When the instrument is used for "SHORT" testing, the coil under test is connected directly across the oscillator tank circuit. Before the component is connected to the test terminals, the position of the meter pointer is adjusted with the CALIBRATION control to the appropriate "CAL" point on the scale as required by the type of component being tested. If the component under test is good, the oscillator will continue to oscillate undamped (although at a much higher frequency than 600 cps) and the meter reading will remain unaffected

or will remain within the "GOOD" section of the appropriate scale. If however, there are shorted turns in the component under test (even as few as one) the shorted section of the coil will absorb power from the oscillator and the meter pointer will dip to the "BAD" section of the scale.

When the instrument is used for "CONTINUITY" testing, the coil under test is connected directly across the meter circuit. Before the component is connected to the test terminals, the meter pointer is set with the CALIBRATION control at the "AIR CORE-CONT. CAL" point, which is used in any type of continuity testing. If the component is continuous, it will shunt the meter circuit and the meter reading will drop to the "GOOD" region on the "CONTINUITY TEST" scale.

## **operation**

### **GENERAL**

The two upper "GOOD-BAD" scales on the meter face, designated "XFMR SHORT TEST" and "YOKE SHORT TEST", are used when "SHORT" testing flyback transformers and yokes respectively. The lowest "GOOD-BAD" scale, designated "CONTINUITY TEST", is used when "CONTINUITY" testing either a flyback transformer or yoke.

The meter pointer must be set at the proper "CAL" point on the scale before connecting either a flyback transformer or yoke to the test terminals for either "SHORT" or "CONTINUITY" testing. The "AIR CORE-CONT. CAL." point is used for both "SHORT" and "CONTINUITY" testing of air-core flyback transformers and all yokes, but only for "CONTINUITY" testing of iron-core flyback transformers. The "IRON CORE CAL." point is used for "SHORT" testing of iron-core flyback transformers.

**NOTE:** The "CONTINUITY" test is useful for continuity checking of power and audio transformer windings, wiring, switches and in any other instance where an ohmmeter would normally be used for continuity testing.

The 0-100 linear reference scale is useful for comparing two identical flyback transformers or yokes, one of which is known to be in good condition and another whose condition is unknown. This is a highly reliable method and is recommended to the operator when the reading obtained is in or near the borderline region between "GOOD" and "BAD". Another use for this scale is to enable the operator to record and repeat any new calibration point that might be necessary if flyback transformers or yokes of radically different impedance are developed in the future.

## OPERATING INSTRUCTIONS

Read the following instructions carefully before using the instrument

### A. Flyback Transformer Testing

1. Turn the TV receiver off and disconnect it from the AC line.
2. Remove the plate caps on the High Voltage Rectifier and Horizontal Output tubes.
3. Remove the HV Rect. tube from its socket. As this instrument is sufficiently sensitive to respond to a closed filament circuit, failure to remove the HV Rect. tube will cause an unjustified "BAD" reading.

NOTE: After the tests have been completed, the HV Rect. tube may be replaced in its socket. If the meter pointer dips with the instrument set for "SHORT" testing, the filament section of this tube is o.k.

4. Unplug the deflection yoke assembly.
5. Unsolder one side of the width coil.
6. Plug the line cord of the Model 944 into a 105-125 volts AC, 50/60 cps outlet and allow the instrument to warm up for one minute.
7. Set the SELECTOR switch at "CONTINUITY" and adjust the CALIBRATION control (with nothing connected across the TEST binding posts) until the meter pointer is at the "AIR CORE-CONT. CAL." point on the scale. This calibration point is used for all "CONTINUITY" testing of flyback transformers (air core or iron core) and yokes.
8. Insert the test leads in the TEST binding posts on the panel and connect them in turn across each winding of the transformer. The meter pointer should dip into the "GOOD" region of the CONTINUITY TEST scale in each test. If the meter pointer remains stationary or remains within the "BAD" region (indicating an open winding or a high resistance connection) on any test, the transformer is defective and disqualified from any further testing.
9. Set the SELECTOR switch at "SHORT" and adjust the CALIBRATION control (with nothing connected across the TEST binding posts) until the meter pointer is set at the "AIR CORE-CONT. CAL." position if you are testing an air core flyback transformer or at the "IRON CORE CAL." position if you are testing an iron core flyback transformer. Connect the two test leads to the two plate cap terminals coming from the transformer. (It is not necessary to

observe polarity.) The meter reading may be higher, lower, or the same as the "CAL." point, but should remain in the "GOOD" region of the "XFMR SHORT TEST" scale. If the meter pointer dips into the "BAD" region, the transformer is defective and should be replaced. The short test is now completed. A short anywhere in the flyback transformer will show up in this test. It is not necessary to perform separate "SHORT" tests on the other windings of the transformer.

## B. Deflection Yoke Testing

1. Performs steps 6 and 7 above.
2. Disconnect one lead of both the Vertical and Horizontal sections of the deflection yoke from the set. In addition, always check the schematic of the TV set to determine whether or not a resistor shunts the Horizontal or Vertical coil. Any resistor shunt must be disconnected for accurate testing of deflection yokes.
3. Insert the test leads in the TEST binding posts on the panel and connect them in turn across the Vertical and Horizontal sections of the deflection yoke. The meter pointer should dip into the "GOOD" region of the CONTINUITY TEST scale on both tests. If the meter pointer remains stationary or remains within the "BAD" region (indicating an open winding or a high resistance connection) on any test, the yoke is defective and disqualified from any further testing.
4. Set the SELECTOR switch at "SHORT". (There is never any need to reset the CALIBRATION control when going from "CONTINUITY" to "SHORT" testing of deflection yokes as the "AIR CORE-CONT. CAL." point is always used for both tests.) Connect the two test leads across the Vertical and Horizontal sections in turn. (It is not necessary to observe polarity.) In each test, the meter reading may be higher, lower, or the same as the "AIR CORE-CONT. CAL." point, but should remain in the "GOOD" region of the "YOKE SHORT TEST" scale. If the meter pointer dips into the "BAD" region when testing either the Vertical or Horizontal section, that section is defective.

## **maintenance**

If you have constructed your instrument from a kit, potentiometer R1 (mounted in the center of the chassis) must be adjusted as described below before the instrument can be used. In factory-wired instruments, potentiometer R1 has already been adjusted properly for the particular 6K6 tube in your unit and a line voltage of 117 volts. If the normal line voltage in your area is substantially higher or lower, you may readjust R1 by this procedure. R1 must be re-



adjusted by this procedure also whenever aging or replacement of the tube or other components makes it necessary.

1. Set the CALIBRATION control at "0" and the SELECTOR switch at either "CONTINUITY" or "SHORT".
2. Plug the line cord into a 105-125 volts AC, 50/60 cps outlet and allow 1/2 hour for the instrument to warm up.
3. Use a screwdriver to turn the slotted shaft of potentiometer R1 to its extreme clockwise position.
4. Set the CALIBRATION control at "10" on the dial.
5. Rotate potentiometer R1 counter-clockwise until the meter pointer reads exactly full-scale.

The adjustment of R1 is now completed and the instrument is ready for use.

#### EICO REPAIR SERVICE

If your instrument fails to function properly and the cause of the trouble cannot be found, you may return it to the EICO repair department where it will be repaired at a charge of \$3.00 plus the cost of parts. (If your instrument has been built from the kit form, refer to the complete statement of the EICO servicing policy in your construction book.) Pack carefully and ship by prepaid Railway Express if possible. Return shipment will be made by express collect.

**EVERYTHING 4 LESS**



**ENJOY YOUR BOOKS**



**PLEASE VISIT OUR STORE FOR EVEN MORE GREAT STUFF!**

**[WWW.EVERYTHING4LESSSTORE.COM](http://WWW.EVERYTHING4LESSSTORE.COM)**

**COPYRIGHT NOTICE**

**ALL MATERIALS INCLUDING CD/DVD AND PDF FILES ARE COPYRIGHTED**

**[WWW.EVERYTHING4LESSSTORE.COM](http://WWW.EVERYTHING4LESSSTORE.COM) VON WALTHOUR PRODUCTIONS AND MAY NOT BE REPRODUCED, COPIED OR RESOLD UNDER ANY CIRCUMSTANCES. YOU MAY HOWEVER MAKE A COPY FOR YOUR OWN PERSONAL BACKUP. MATERIALS ARE FOR PERSONAL USE ONLY.**

**IF YOU PURCHASED THIS FROM ANYWHERE BUT FROM US PLEASE NOTIFY US IMMEDIATELY SO THAT WE MAY CHECK IF YOU PURCHASED FROM AN AUTHORIZED RESELLER SO WE CAN LET YOU KNOW IF YOU NEED TO RETURN FOR FULL REFUND FROM AN UNAUTHORIZED SELLER.**

**THANKS AGAIN AND PLEASE TAKE THE TIME TO VISIT OUR STORE.**

**ATTENTION! EVERYTHING ON SALE NOW!!**



**HOT SALE!**

**THIS PAGE COPYRIGHT VON WALTHOUR PRODUCTIONS  
[WWW.EVERYTHING4LESSSTORE.COM](http://WWW.EVERYTHING4LESSSTORE.COM)**

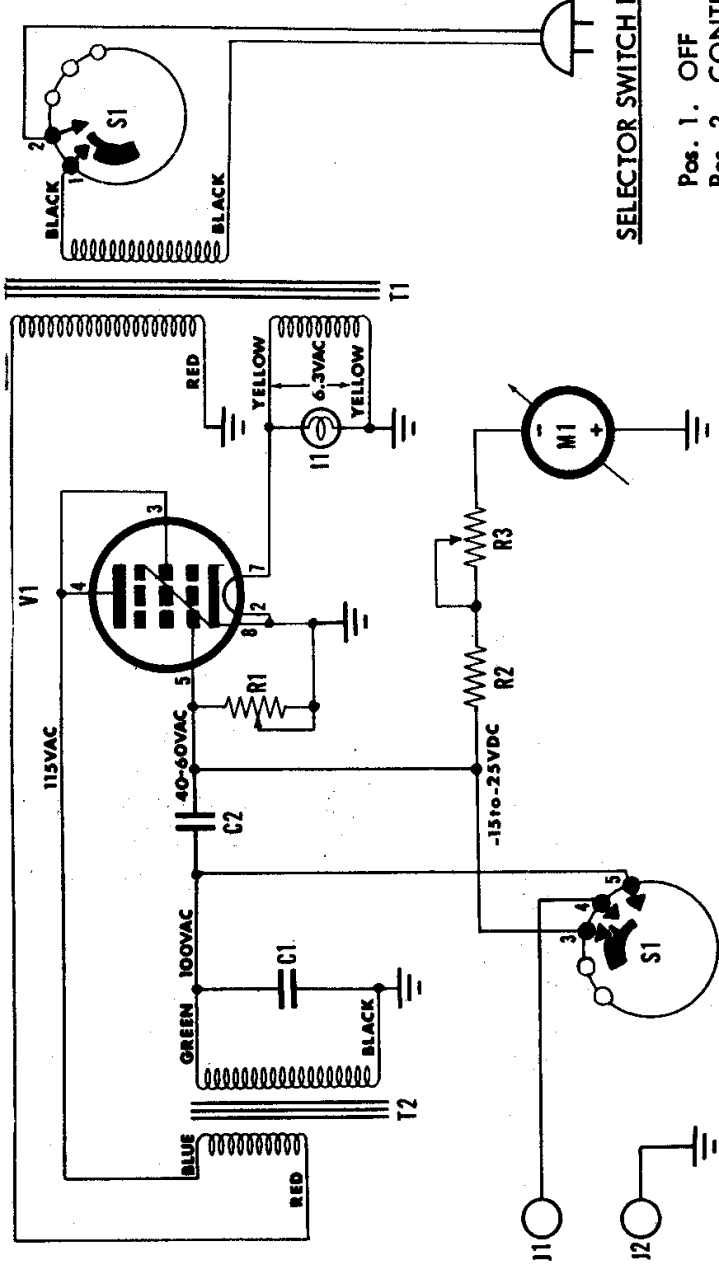

**SELECTOR SWITCH POSITIONS**

- Pos. 1. OFF
- Pos. 2. CONTINUITY
- Pos. 3. SHORT

Stock#	Sym.	Description	Am't.	Stock#	Sym.	Description	Am't.
20002	C1	cap., .002 mf	1	16011	R3	pot., 2MΩ, calibration	1
21000	C2	cap., .001 mf	1	60029	S1	switch, 3 pos., selector	1
92000	I1	bulb #47	1	30013	T1	transformer, power	1
72005	M1	meter movement, 50 ua	1	32001	T2	transformer, osc.	1
18000	R1	pot., 2MΩ w/slotted shaft (int.)	1	90005	V1	tube, 6K6	1
10027	R2	res., 270KΩ, 1/2W	1				

**MODEL 944 FLYBACK XFMR and YOKE TESTER**