INSTRUCTION MANUAL



www.everything4lessstore.com



783 Malta Street, Brooklyn, N.Y.

Courtesy of N7RK

www.everything4lessstore.com

EVERYTHING 4 LESS

ENJOY YOUR BOOKS

PLEASE VISIT OUR STORE FOR EVEN MORE GREAT STUFF!

WWW.EVERYTHING4LESSSTORE.COM

COPYRIGHT NOTICE

ALL MATERIALS INCLUDING CD/DVD AND PDF FILES ARE COPYRIGHTED

WWW.EVERYTHING4LESSSTORE.COM VON WALTHOUR PRODUCTIONS AND MAY NOT BE REPRODUCED, COPIED OR RESOLD UNDER ANY CIRCUMSTANCES. YOU MAY HOWEVER MAKE A COPY FOR YOUR OWN PERSONAL BACKUP. MATERIALS ARE FOR PERSONAL USE ONLY.

IF YOU PURCHASED THIS FROM ANYWHERE BUT FROM US PLEASE NOTIFY US IMMEDIATELY SO THAT WE MAY CHECK IF YOU PURCHASED FROM AN AUTHORIZED RESELLER SO WE CAN LET YOU KNOW IF YOU NEED TO RETURN FOR FULL REFUND FROM AN UNAUTHORIZED SELLER.

THANKS AGAIN AND PLEASE TAKE THE TIME TO VISIT OUR STORE.

ATTENTION! EVERYTHING ON SALE NOW!!



HOT SALE!

IN-CIRCUIT CAPACITOR TESTER



TABLE OF CONTENTS

	Page
SECTION I. GENERAL DESCRIPTION AND FACILITIES	
1-1. General Description	2
1-2. Facilities	2
SECTION II. OPERATING INSTRUCTIONS	
2-1. Controls and Terminals	2
2-2. Operation	4
a) Preliminary Operations	4
b) Circuit Preparation	4
c) Polarity	4
d) Short Test	5
e) Open Test	5
f) Capacity Measurement	5
SECTION III. CIRCUIT DESCRIPTION	
3-1. Circuit Description	7
Short Test	7
Open Test	8
Capacity Test	8
SECTION IV. MAINTENANCE	
4-1. General	9
4-2. Case Removal	9
4-3. Open Test Sensitivity Adjustment	9
4-4. Trouble-Shooting Chart	9-10
SECTION V. PARTS LIST	11
SECTION VI. EICO SERVICE POLICY	13

FIGURES

SECTION I. GENERAL DESCRIPTION AND FACILITIES	
Photo. Eico Model 955	1
SECTION II. OPERATING INSTRUCTIONS	
Fig. 2-1. Front Panel Control and Terminals	3
Fig. 2-2. Example	5
Fig. 2-3. Example	7
Graph. Dissipation & Power Factor vs. RC	16
SECTION III. CIRCUIT DESCRIPTION	
Fig. 3-1. Short Test Circuit	7
Fig. 3-2. Open Test Circuit	8
Fig. 3-3. Capacity Measurement Circuit	8
SECTION IV. MAINTENANCE	
Fig. 4-1. Tube Layout and Tuning Adjustment	11
Fig. 4-2. Schematic Diagram w/Switching Table for 955	15

SECTION I. GENERAL DESCRIPTION AND FACILITIES

1-1. GENERAL DESCRIPTION

The Model 955 is a truly advanced, highly dependable in-circuit and out-of-circuit capacitor tester. In addition to providing extraordinarily sensitive short and open tests, the Model 955 includes a Wien Bridge for capacity measurements, with a unique shunt resistance balancing provision* that permits in-circuit measurement even when the shunting resistance is comparatively low.

1-2. FACILITIES

Indicator: Electron-ray tube EM84/6FG6. Bright bar pattern gives sharp, unmistakable indications.

Test Selector: Three-position switch — SHORT, CAPACITY, OPEN

Test Leads: One coax-type for all tests; detachable, with input connector coupling to unit.

Short Test: Out-of-circuit or in-circuit short check with shunt resistance as low as 1 ohm. Reliable up to 2000mf. Closed bars indicate short. 60 cps test frequency. Max. test voltage 6.3VAC (open leads), decreasing with decreasing impedance.

Open Test: Out-of-circuit or in-circuit open test of capacitors as small as 15mmf with instrument adjusted normally. (With constant voltage supply, internal adjustment can be made for 5mmf sensitivity). For in-circuit testing, shunt resistance may be as low as 35 ohms for capacitors above 100mmf (3KΩ at 10mmf). Closed bars indicate open. Test frequency approximately 22Mc, very low voltage.

Capacity Measurement: From 0.1 to 50mf using Wien Bridge with unique shunt resistance balancing* permitting ±10% accuracy at any point on the capacity dial in either in-circuit or out-of-circuit measurement. The capacity scale is screened on a 4" diameter, heavy-gauge lucite disc. The reading point is just above the center of the indicator bar-pattern. Operating frequency of the bridge is 60 cps.

The RC BALANCE control is calibrated in RC product (equivalent shunt resistance in kilohms multiplied by the capacitance in microfarads) in two ranges, 0.6 to 10.5 and 7 to infinity, selected by the RC RANGE switch. The very wide RC product range provided, with excellent spread permitting easy setting to any value, is the key to the accurate capacity measurement provided either in or out of circuit. For out-of-circuit measurements, the RC product value can be translated into dissipation or power factor with the help of the graph on page 16.

*Patent applied for

Line Voltage: 105 to 130VAC. 60 cps; 8 watt drain. A LINE ADJ control on the panel permits adjustment to maximum sensitivity regardless of the voltage variation within this range.

Miscellaneous: Exceptionally attractive, professional laboratory styling. Transformer operated and protected by fuse in extractor-post mount.

Tubes: 1-6C4, 1-EM84/6FG6.

Size (HWD): 8 1/2" x 8 3/4" x 8"

Weight: 4 lbs.

CAUTION

This instrument is provided with the highest sensitivity practical in its class, thus permitting the lowest practical test voltage. This low test voltage permits practically all capacitors commonly encountered to be tested. Even this low test voltage, however, would exceed the ratings of some capacitors, which should therefore not be tested with this instrument to avoid the possibility of damaging them. These capacitors may be encountered in special sub-miniature equipment, as well as in equipment working on very low voltages. As a rule, testing of capacitors with rated DC working voltage below 6 volts with this instrument should be avoided; for capacitors between 9 and 6 volts rated, the short-test should not be prolonged. Testing of all types of polarized tantalum capacitors, regardless of their working voltages, also should be avoided, as these capacitors can be tested only with a polarized a-c bridge (never applies reverse polarity voltage). Tantalum capacitors are easily recognizable by their very small dimensions for a given capacitance and working voltage.

SECTION II. OPERATING INSTRUCTIONS

2-1. CONTROLS AND TERMINALS

TEST switch

Provides selection of the desired test. Three positions for selection of the short test, capacity measurement, or open test.

.1-50MFD Capacity Dial

Provides balance for the capacitive component of the tested impedance. 4" in diameter transparent dial is read at hairline on panel, just above the indicator bar-pattern, after the bridge is balanced.

RC RANGE switch

Provides selection from two ranges of RC Balance: 0.6-10.5 and 7-INFINITY.

RC BALANCE control & AC POWER switch

When the control is turned past maximum (counter-clockwise rotation of the potentiometer to the OFF



Fig. 2-1. Front Panel Controls and Terminals

position, the instrument is disconnected from the AC power line. Clockwise rotation from OFF turns the instrument on, as indicated by the pilot lamp located just below this control. The RC BALANCE control provides balance for the resistive component of the tested impedance such as shunting resistance and/or equivalent parallel resistance or equivalent series resistance of the tested capacitor. The reading from the RC BALANCE dial (either range according to the setting of the RC RANGE switch) can be converted into equivalent shunting resistance, dissipation factor, or power factor, as desired and in keeping with the test situation. The setting of the RC BALANCE control is not significant when the instrument is set for the short test or open test except that it must be turned clockwise from the OFF position.

INPUT CONNECTOR

Input connector provides positive connection to the test cable furnished with a matching connector.

LINE ADJ control

Provides convenient compensation for line voltage variation from 105V to 130 VAC, assuring proper functioning of the instrument for all supply voltages within this range.

FUSE

An extractor post fuseholder on the rear apron contains a cartridge fuse in the primary circuit of the power transformer. This fuse is a standard type, rated 1/2 ampere.

2-2. OPERATION

NOTES

Adequate ventilation is necessary for proper operation of the instrument and to avoid the possibility of heat damage. The use of a perforated case permits convective movement of air through the instrument to remove the heat generated by tubes and other components. The air movement consists of cool air, drawn through the sides of the case, being heated and escaping through the top. Take sensible measures to avoid impeding the required air flow.

The test cable supplied is used for all functions. However, its exact length, cable type, and construction is determined by the open test circuit, which is designed to match this cable. No substitute for this cable that differs even slightly in length, type, or construction is acceptable in the OPEN test function and therefore, this exact cable must be considered an electrically inseparable part of the instrument circuit. It is made detachable in the interest of convenient portability of the instrument and to permit easy replacement. You are strongly advised, however, not to disconnect the cable from the instrument, unless you have to for such reasons as mentioned above. Otherwise the cable may be mislaid, or a similar looking cable connected to the instrument by mistake. If the test cable is replaced, internal re-adjustments are required (see Maintenance-Section 4).

CAUTION

The instrument should be connected to a 100 - 130 VAC 60 cps supply line only. It will not operate from, nor should it be connected to, any other kind of supply.

a. PRELIMINARY OPERATIONS

1. Rotate the RC BALANCE control clockwise from the OFF position to switch the instrument on. This is indicated by the glowing pilot light.

2. Allow a 5-minute warm-up period, during which the electron-ray indicator tube will attain its characteristic green glow and the instrument will reach conditions required for normal operation.

3. Set the TEST selector at SHORT, and short the test clips.

4. Set the LINE ADJ control so that the green bars of the indicator tube close together at the center without overlapping. This condition will be referred to as "closed bars".

5. Separate the test clips. The instrument is now ready for use.

NOTE: Steps 3, 4, and 5 should be repeated regularly often to compensate for possible changes in the supply line voltage.

b. CIRCUIT PREPARATION

Whenever a capacitor is tested in a circuit, the circuit as a whole should be switched off and disconnected from its supply, and all capacitors should be discharged. When batteries are used in the circuit under test as an additional supply, or as the sole supply, the batteries should be removed and capacitors discharged. Failure to discharge any charged capacitors before testing may well result in damage to the instrument as well as erroneous test results. Whenever a capacitor is tested out of a circuit, make sure that it is discharged.

Discharge of the capacitor before testing is also a general personal safety precaution.

c. POLARITY

When connecting the test leads to the capacitor under test, it is advised to follow this simple rule:

1. The black test lead should be connected to the terminal of capacitor which under normal working conditions has a potential closer to that of the chassis.

2. The red test lead should be connected to the remaining terminal of the capacitor.

If the above rule is not followed, there will be no change in indication or accuracy in the short test and capacity test, but there may occur a slight drop in sensitivity on the open test. If the highest sensitivity is not important for the particular test, the rule can obviously be ignored.

d. SHORT TEST

1. Set the TEST selector to SHORT.

2. Connect the test clips to the capacitor under test. The use of additional test leads of reasonable length connected to extend the regular test leads is, in this test, permissible.

3. The indicator tube bars will remain open (at least a small gap) if the impedance across the test clips is more than 1 ohm (at 60 cps). Only closed bars indicate impedance less than 1 ohm. (Note that a 2000mfd capacitor has an impedance of 1.33 ohms at 60 cps). Partially open bars indicate an impedance between 1 ohm and 10 ohms. (Note that a 200mfd capacitor has an impedance of 13.3 ohms at 60 cps.) A short or very low resistance across a good capacitor will also cause a "short" indication. Check for this condition before discarding the capacitor as internally shorted.

The instrument may also be used as a continuity tester in the SHORT position of the TEST selector.

e. OPEN TEST

1. Set the TEST selector to OPEN.

2. Connect the test clips directly to the capacitor under test. (No additional test leads may be used.)

3. The indicator tube bars will remain open (at least a small gap) if the capacitance across the test clips is more than 15mmf. Only closed bars indicate an open capacitor or a capacitance of less than 15mmf. Partially open bars indicate capacitance below 25mmf but more than 15mmf. If the latter indication is obtained when testing a capacitor greater than 25mmf in-circuit, it may be due entirely to stray capacity and the tested capacitor may be open. On the other hand, a capacitor below 100mmf that is not open, may show open in-circuit if it is shunted by a resistance below a critical value. This is discussed in (8) below. Also, some types of tubular electrolytics may show open due to a peculiarity of their construction, even though they are almost always not open. This is discussed in (9) below. Circuit examination in the first case, and capacity measurement in the second case will always settle any doubts.

4. An in-circuit open test should not be given to capacitors shunted with a resistance of less than 35 ohms because a false indication will occur. The actual limit is somewhat lower and can be found for each particular instrument by a simple check with a resistor connected across the test leads. (With the critical value or less, the instrument will show "not open" with

only a resistor but no capacitor across the test clips.)

5. A good capacitor connected in parallel with an open one may cause an indication "not open". Therefore, all indications should be interpreted on the basis of circuit examination. For example, in Figure 2-2, if R is less than 35 ohms and C_A is open, but C_B is large, the indication may be "not open" while checking C_A because small R does not isolate the capacitors sufficiently. In the same case, but with R larger than 35 ohms, the indication will be correct.

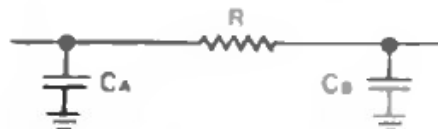

Fig. 2-2. Example

6. The open test may give false indication on capacitors in resonant circuits unless the resonant frequency of the circuit is much below the test frequency (approximately 22Mc.) False indication is very likely in open-testing capacitors in resonant circuits above 22Mc.

7. The sensitivity given in (3) above as 15mmf is the lowest sensitivity that will be obtained with the supply line voltage at 105 VAC. With the line voltage at 115 VAC, the sensitivity will rise to 10mmf, and with the line voltage about 130 VAC there will be a gap between the indicator tube bars with a capacitance as low as 5mmf between the test clips. The instrument can be adjusted for the highest sensitivity at any given line voltage within the range 105V - 130V (see 4-3.1). This is advisable only if the highest sensitivity is really necessary, and when the instrument can be supplied with a stable supply line voltage (as e.g. through an a-c voltage stabilizer), because the highest sensitivity can be achieved for one particular supply line voltage only, and with higher line voltages there will be a gap between the indicator tube bars even with an open circuit between the test clips.

8. As stated in (3) above, a capacitor below 100mmf that is good may show open in-circuit if it is shunted by a resistance below a critical value. The critical resistance value varies in an inverse manner with the capacitance value as follows:

3K Ω	for 10mmf
1.5K Ω	for 15mmf
750 Ω	for 20mmf
500 Ω	for 25mmf
250 Ω	for 50 mmf
50 Ω	for 100mmf

When the shunt resistance is close to the critical limit for the particular capacitance value, the indicator tube bars may open only partially. Additional tests can be performed, and positive indication can be obtained, after disconnecting one end of the capacitor (or the shunt resistance, if this is easier) and checking again the same way.

9. As stated in (3) above, some types of tubular electrolytic capacitors (depending on their internal structure) will give an open indication in most in-circuit cases, and always show open out of the circuit. Some of them, for the same reason, may give only a partial opening of the indicator tube bars, which could be interpreted as stray capacity or capacitance of less than 25mfd. Whenever these indications are obtained with an electrolytic capacitor (they very seldom are really open) the instrument should be switched to the CAPACITY test and a capacity measurement should be performed to determine the capacitance.

1. CAPACITY MEASUREMENT

1. Set the TEST selector to CAPACITY.

2. If the values of the expected capacitance and parallel resistance are known, set the RC RANGE switch and the RC BALANCE control to indicate a value slightly higher than the product received by simple multiplication of the value of the expected capacitance in mfd by the value of the expected (or measured with an ohmmeter) resistance in kilohms. When the values are not known, set the RC RANGE switch to the 7-INF position and the RC BALANCE control to INF.

3. Connect the test clips to the capacitor under test. The use of additional test leads of reasonable length connected to extend the regular test leads is, in this test, permissible.

4. Rotate the capacity dial to find the position in which the indicator tube bars have the smallest gap. Then rotate the RC BALANCE control counterclockwise until the gap becomes a little smaller (do not try to close the gap by rotating the RC BALANCE control only). Correct the position of the capacity dial for the smallest gap and then again close the gap partially by rotating the RC BALANCE control. By repeating this procedure a few times, a point of balance will be achieved indicated by a complete closure of the gap between the indicator tube bars with the largest possible overlapping. (Overlapping appears as a bright line at the bar closure point, the brightness of the line increasing with the degree of overlapping.)

The point of balance should be approached always by rotating the RC BALANCE control counterclockwise and without going beyond the point of best balance. For instance, when balance cannot be achieved at the 7-INF position of the RC RANGE switch, and it is necessary to go to lower values of RC — after the RC RANGE switch is set at the .6-10.5 position — the RC BALANCE control should be turned fully clockwise and then the point of balance should be approached again by rotating the RC BALANCE control counterclockwise toward balance, alternately with correcting the capacity dial setting, as described above. Disregard of this procedure may lower the accuracy of the measurement.

When measuring a capacitor in a circuit where the RC is high, or when the capacitor is out of the circuit, very often it is possible to achieve a complete closure of the gap between the indicator tube bars by rotating the capacity dial only. Nevertheless, in most cases it is possible to improve the balance with the use of the RC BALANCE control. In some cases when the

capacitance is more than 15mf, it may happen that the balance position of the RC BALANCE control is not indicated sharply and the setting can be varied over a wide range without a significant change in indication. However, the balance indication achieved with rotating the capacity dial will still be sharp enough to give the value of the capacitance with the usual accuracy.

5. To assure maximum accuracy in capacity measurement, observe the following rule:

- If the RC product is between 7 and 10 on in-circuit measurement, use the .6-10.5 position of the RC RANGE switch for balancing.
- In the same circumstances on out-of-circuit measurement, use the 7-INF position.

6. After the bridge is properly balanced, the value of the capacitance can be read directly from the capacity dial. When used properly, and according to the procedures given, the instrument will indicate the values of capacitance with an error not exceeding 10% unless the power factor of the capacitor under test is more than 30%. With the value of the power factor exceeding 30%, the error becomes larger and can be roughly estimated as follows:

$$\frac{(PF)^2}{100} \% \quad PF \text{ is the power factor in percent.}$$

Practically speaking, the increase of the error can be neglected in many cases because the indicated capacitance is the equivalent parallel capacitance, which is what counts when the capacitor is used for filtering. A large decrease of the equivalent parallel capacitance caused by the loss of capacity itself, as well as by the increase of the power factor, should be considered a sufficient indication that the capacitor under test should be replaced.

7. At balance, the setting of the RC BALANCE control indicates the value of RC product, defined as the product of multiplying the value of measured capacitance in mfd and the value of the parallel resistance in kilohms. Therefore, the value of the parallel resistance can be determined by simply dividing the value indicated on the appropriate range of the RC BALANCE dial by the value of capacitance indicated on the capacity dial. It is necessary to remember that the parallel resistance determined in this manner will be in most cases lower than that measured with an ohmmeter, because the internal equivalent parallel resistance of the capacitor appears to be connected in parallel with the external parallel resistance and lowers the resultant value. With this explanation it becomes obvious that the difference will be larger with capacitors having a high power factor and smaller with capacitors having a low power factor, larger where capacitors are connected in parallel with high resistances and smaller where these resistances are low. When the capacitor under test is out of the circuit, the indication from the RC BALANCE dial can be converted into the dissipation factor or power factor with the help of the graph given on page 16.

8. A balance indication above the 50mf mark indicates a large capacitance beyond the range of the capacity dial, or a short. Which is the case, can be determined by applying the short test. A balance indication beyond the 0.1mf mark indicates a small capacity beyond the range of the capacity dial (with not less than 3K ohms in parallel), or an open circuit. Which is the case can be determined by applying the open test.

9. To avoid false and misleading indications, the rules given below should be followed closely:

- a. Capacitors connected in parallel with a resistance of less than 35 ohms should not be measured because this may cause false indication. These capacitors should be measured after one end of the capacitor is disconnected, or after a part of the parallel circuit is disconnected, so as to bring the parallel resistance to some higher value, whichever is easier. To determine the value of the parallel resistance, a check with an ohmmeter is advised rather than relying on the schematic values.
- b. Do not attempt to measure capacitors known to be out of the 0.1 to 50mfd capacity range or capacitor-resistance parallel combinations having an RC product less than 1.0. Either or both conditions exclude the possibility of in-circuit measurement. The best thing to do in these cases is to disconnect one end of the capacitor and measure it effectively out of circuit, provided of course, that it is greater than 0.1mfd. Stating the same thing from another point of view; should it be found that balance can not be obtained within the 0.1 to 50mfd capacity dial range and the 1 to INF RC BALANCE range, then either the capacity is outside the measuring range of the instrument, or the RC product is below 1 (the useful low limit of RC BALANCE provided) or both. Again the best thing to do is to disconnect one end of the capacitor and measure it effectively out-of-circuit. If balance can not be obtained between 0.1 and 50mfd in the out-of-circuit measurement, then the capacity value is out of the measuring range of the instrument, and the only tests that can be applied to the capacitor by this instrument are the short and open tests.
- c. Whenever a capacitor under test is connected in parallel with another capacitor, the indication at the point of balance will give the resultant capacitance of this parallel combination. Measurement of these capacitors separately can be performed only after the lead that connects them in parallel is disconnected at one point.
- d. When two or more capacitors are connected in an RC-type network (see figure 2-3), the capacitors next to the measured one should be shorted to eliminate possible errors. Of

course the requirements of a. and b. above have to be met.

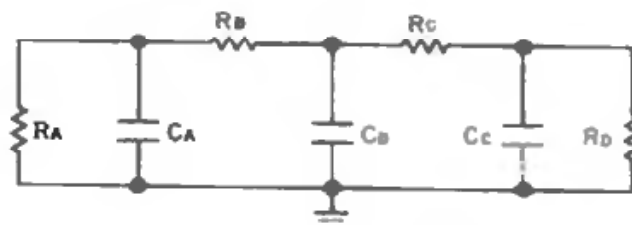

Fig. 2-3. Example

EXAMPLE:

1. To measure Ca, short Cb. It is required that

$$\frac{R_a \times R_b}{R_a + R_b} > 35 \text{ ohms}$$

and that $\frac{C_a \times R_a \times R_b}{1000 (R_a + R_b)} > 1.0$. The resistance

is in ohms and capacitance in mfd.

2. To measure Cb, short Ca and Cc. It is required that the values of

$$\frac{R_b \times R_c}{R_b + R_c} > 35 \text{ ohms}; \quad \frac{C_b \times R_b \times R_c}{1000 (R_b + R_c)} > 1.0$$

3. To measure Cc, short Cb. It is required that the values of

$$\frac{R_c \times R_d}{R_c + R_d} > 35 \text{ ohms}; \quad \frac{C_c \times R_c \times R_d}{1000 (R_c + R_d)} > 1.0$$

SECTION III. CIRCUIT DESCRIPTION

3-1. CIRCUIT DESCRIPTION

SHORT TEST

With the TEST selector at the SHORT position, the part of the circuit employed can be shown in a simplified schematic given in figure 3-1.

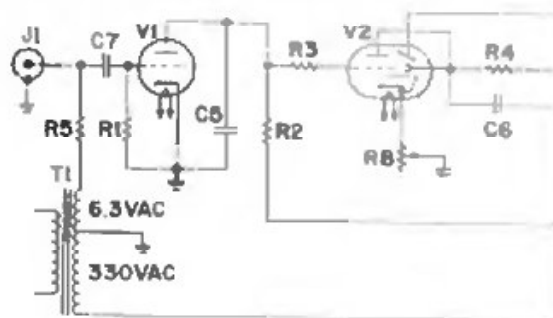

Fig. 3-1. Short Test Circuit

The a-c voltage (330 VAC) from transformer T1 is applied to the plate of V1 through the resistor R2. At the same time a small a-c voltage (6.3 VAC) of opposite phase is applied to the grid of V1 through R5 and C7, and the same voltage is applied to the capacitor under test. Whenever the impedance across the test leads is more than 10 ohms the voltage appearing on the grid of V1 is large enough to keep the plate current in V1 down to very low values (keep in mind the phase opposition of the grid and plate voltages). The voltage drop across R2 will then be very small and with a properly set LINE ADJ (R8) control, this will make the grid of the triode part of V2 very slightly negative with respect to the cathode. The plate current of V2 will therefore be comparatively high. This will cause a large voltage drop across R4. With a large difference of potential between the ray-control electrode and the target, the indicator tube bars will be wide open. When the test leads (or the capacitor across them) are shorted, the grid of V1 is at the same potential as the cathode. The plate current in V1 increases and the voltage drop across R2 increases. The grid of the triode section of V2 becomes much more negative with respect to the cathode, and the plate current in the triode section decreases. The voltage drop across R4 decreases accordingly, so that the potential difference between the ray-control electrode and the target decreases and the indicator tube closes. With the impedance across the test leads between 0 and 1 ohms the indicator tube bars are closed (occasionally a more sensitive set may have the limit even below 1 ohm); and with the impedance between 1 and 10 ohms, the indicator tube bars are partially open.

OPEN TEST

With the TEST selector at the OPEN position, the part of the circuit employed can be shown in a simplified schematic given in figure 3-2.

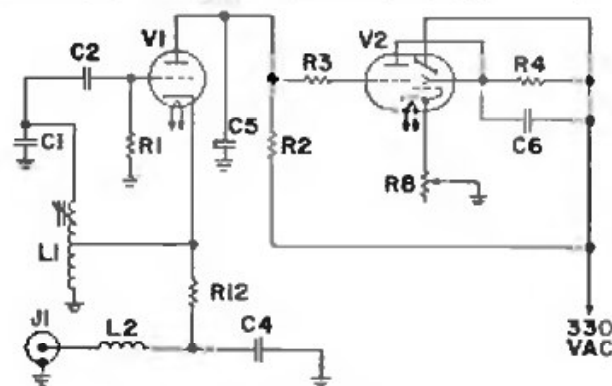

Fig. 3-2. Open Test Circuit

With the exception of R12, C4, and L2, the circuit connected to V1 represents a simple Hartley oscillator. Whenever there is oscillation in the circuit of C1 and L1, the grid of V1 is negative, and the plate current in V1 very small; consequently (see above) the indicator tube bars stay open. When there is no oscillation in the circuit of C1 and L1, the grid of V1 is at the same potential as the cathode, and the plate current is large; consequently, the indicator tube bars are closed. The presence of oscillation in the circuit depends on the impedance connected across the test leads. The test

cable together with L2, R12 and C4 represents a quarter wave-length line for the frequency of oscillation (about 22Mc). This quarter wave-length line is connected to L1. Whenever this line is open at the end with test leads, it represents a short at the input, and this means that a part of coil L1 will appear shorted. This will obviously suppress the oscillation in the circuit of C1 and L1, and keep the indicator tube bars closed. With an impedance of sufficient value at the end of the test cable with the test leads, the line will represent at the input an impedance large enough to maintain the oscillations in circuit of L1 and C1, and keep the grid of V1 negative. This will cause the indicator tube bars to open.

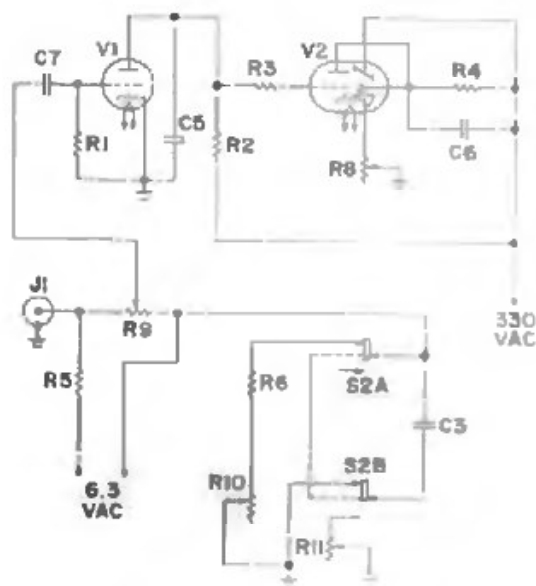

Fig. 3-3. Capacity Measurement Circuit

CAPACITY MEASUREMENT

With the TEST selector at the CAPACITY position, the part of the circuit employed can be shown in a simplified schematic given in figure 3-3. The circuit ahead of C7 represents a series and parallel capacitance comparison bridge, and the circuit after C7 represents an indicator. Whenever the bridge is balanced, the voltage coming from the bridge to the indicator is zero. The grid of V1 is then at the same potential as the cathode and the plate current in V1 is large. This keeps the indicator tube bars closed. With a non-zero voltage coming from the bridge (the bridge out of balance) the grid of V1 becomes negative, and the indicator tube bars are open — at least partially. The bridge circuit is somewhat different from the bridges in common use. The resistance balancing potentiometer is connected in series with the standard capacitor only for the high values of RC (or low values of dissipation factor or power factor). For low RC, the resistance balancing potentiometer is connected in parallel with the standard capacitor. This way it is possible to measure capacitors shunted with small resistances with a comparatively high accuracy of capacity measurement.

SECTION IV. MAINTENANCE

4-1. GENERAL

Your instrument will normally require little service outside of tube replacement. The performance of the instrument is not dependent on tube selection and both types employed are available nationally.

All of the required adjustment procedures are described in this section. Trouble-shooting information is provided also. Operating voltages and transformer winding resistances are shown on the schematic diagram. In reading the schematic diagram it may be found helpful to refer to the simplified schematics given in Section 3.

4-2. CASE REMOVAL

Loosen and remove the two sheet metal screws at the rear. Slide the case out of the panel frame and off the instrument.

4-3. OPEN TEST SENSITIVITY ADJUSTMENT

Remove case. Connect test lead to instrument. Perform PRELIMINARY OPERATIONS, Section 2-2a, allowing a half-hour warm-up before setting LINE ADJ control. For best results, the actual line voltage at the time of the following adjustments should be determined as accurately as possible. The tuning slug of coil L1 (located in Figure 4-1) should be adjusted with a tuning wand or an insulated screwdriver.

- a. Set the TEST selector at OPEN.
- b. Straighten out the test lead and separate the test clips.
- c. Turn the slug in L1 to its maximum counter-clockwise position. Do not force it or the slug will break. At this point, there will be some gap between the bars in the indicator tube.
- d. Turn the L1 slug slowly clockwise until the gap is just closed. Do not turn it beyond this point.

- e. Now turn the L1 tuning slug further clockwise, to an extent depending on the measured line voltage at the time of test, as follows:

105 volts	- 1 turn clockwise
111 volts	- 3/4 turn clockwise
117 volts	- 1/2 turn clockwise
123 volts	- 1/4 turn clockwise
129 volts	- do not turn at all

The purpose of the added turning of the L1 slug is to cover a 10% line voltage variation.

If the line voltage cannot be accurately measured and there is no reason to believe that it is abnormally high or low at the time, then assume it is 117V and add 1/2 turn clockwise, as indicated above.

If the instrument is supplied from a stabilized a-c voltage supply, no additional turning of the L1 slug is necessary after adjusting it for closure of the indicator tube bars as described.

- f. Short the test clips. The indicator tube bars should open wide. This completes the adjustment; disconnect the instrument from the power line and replace the case.
- g. With aging or part replacement, it will probably be necessary to perform the entire OPEN TEST SENSITIVITY ADJUSTMENT given above again. There are two possible indications that this is necessary:
 1. After completing step h above, there is a considerable gap between the indicator tube bars.
 2. The sensitivity of the instrument on the open test drops considerably.

4-4. TROUBLE-SHOOTING CHART

The chart is given with the assumption that the wiring of the instrument was checked and found correct and in good order, the solder joints were checked, and the resistances measured and found within tolerances.

4-4. TROUBLE SHOOTING CHART.

SYMPTOM	POSSIBLE CAUSE & REPAIR PROCEDURE
Instrument inoperative, pilot light does not glow.	Blown fuse — check and replace if necessary. Defective line cord or defective on-off switch S3 — check for primary resistance of T1 through line cord plug with the RC BALANCE control turned clockwise from OFF.
Instrument inoperative, pilot lamp does glow but indicator tube does not glow.	Defective tube V2 — check and replace if necessary. No filament voltage — check between pins 4 and 5 of V2. No plate voltage — check at pin 6 of V2. Defective potentiometer R8 LINE ADJ — check resistance between pin 3 of V2 and chassis for zero resistance at the extreme counter-clockwise position and 50 kilohms at the extreme clockwise position.
Instrument inoperative, pilot lamp and indicator tube glow.	Defective tube V1 — check and replace if necessary. Defective test lead or bad contact on the input jack — check by shorting the inner and outer conductor terminals of the input jack with the TEST selector at SHORT. Defective switch S1 — check. Defective capacitor C7 — short pin 6 on V1 to chassis. If the instrument can be adjusted for closing of the indicator tube columns with the use of the LINE ADJ. control, then replace C7.
Instrument performs properly on the SHORT test but does not work properly on the CAPACITY test.	Make sure that this is the case by performing the CAPACITY test on a good capacitor alone and then with a parallel resistance (e.g. 2mf along with the RC RANGE switch in the position "7-INF" and 2mf shunted by 500 ohms with the RC RANGE switch in the position "0.6 - 10.5" and the RC BALANCE control about 1.0). Defective switch S1 — check. Defective potentiometer R9, R10, or R11 — check. Defective switch S2 — check. Defective capacitor C3 — check.
Instrument performs properly on the SHORT test, but on the OPEN test it does not work properly or the indicator tube bars stay closed with shorted test clips.	Instrument requires readjustment — see Section 4-3. If the readjustment can not be done, it may be: Weak tube V1 — check and replace if necessary. Defective or wrong test lead — check for length and type of cable and its condition. Defective switch S1 — check. Defective part in circuit formed by C1, C2, R12, C4, C5, L1, and L2.
Instrument is entirely operative and performs properly, but pilot light does not glow.	Defective indicator light I1 — check and replace if necessary.
Instrument is operative but does not work properly on the CAPACITY measurement (check as above), and in the SHORT test the gap on the indicator tube with separated test leads is very wide (the bars disappear from view), or the edges are not sharply defined; line adjustment difficult.	Defective capacitor C6 — check and replace if necessary.

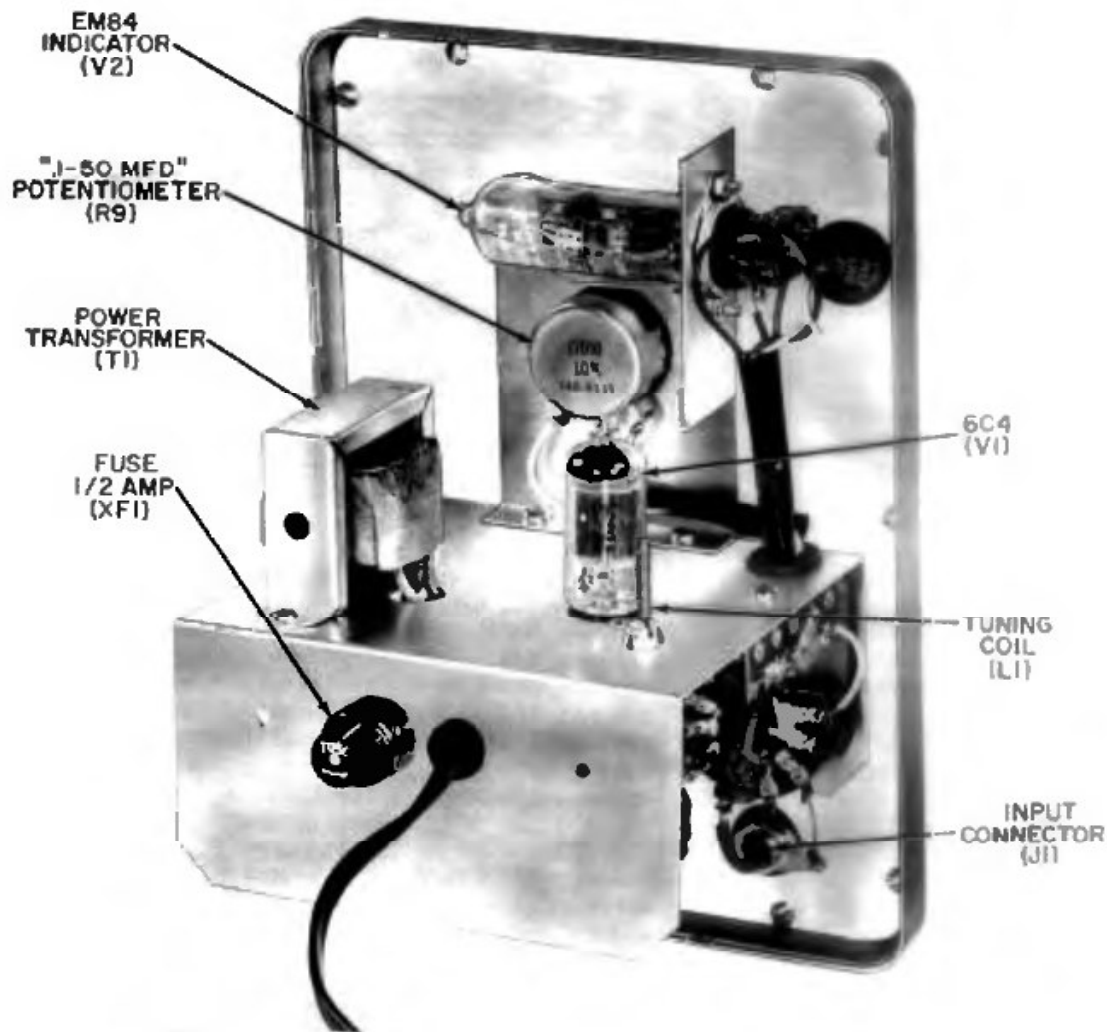

Fig. 4-1. Tube Layout and Tuning Adjustment

REPLACEMENT PARTS LIST

SYM.#	STOCK#	AM'T.	DESCRIPTION
C1	22533	1	capacitor, disc, 47mmf, 10%
C2	22534	1	capacitor, disc, 68mmf, 10%
C3	20501	1	capacitor, paper, 2mfd, 150V, 2%
C4	22536	1	capacitor, disc, 25mmf, 10%
C5	22500	1	capacitor, disc, .001mfd (1K or 1000mmf), GMV
C6	22510	1	capacitor, disc, .02mfd (20K or 20,000mmf), GMV
C7	20001	1	capacitor, paper, .05mfd, 400V, 20%
F1	91007	1	fuse, .5 Amp, 3AG
I1	97715	1	indicator, neon
J1	50002	1	connector, male
L1	36019	1	coil, variable oscillator
L2	35058	1	choke, 1uh
P1	51000	1	connector, female
R1	10407	1	resistor, 1M ohm, 1/2W, 10% (brown,black,green,silver)
R2	10435	1	resistor, 150K ohm, 1/2W, 10% (brown,green,yellow,silver)
R3	10455	1	resistor, 1.5M ohm, 1/2W, 10% (brown,green,green,silver)
R4	10408	1	resistor, 680K ohm, 1/2W, 10% (blue,gray,yellow,silver)
R5	10965	1	resistor, 33 ohms, 2W, 10% (orange,orange,black,silver)

REPLACEMENT PARTS LIST (Cont'd)

SYM.#	STOCK#	AM'T.	DESCRIPTION
R6	10446	1	resistor, 270 ohms, 1/2W, 10% (red,violet,brown,silver)
R7	10426	1	resistor, 33K ohm, 1/2W, 10% (orange,orange,orange,silver)
R8	18089	1	potentiometer, 50K ohm, (LINE ADJ.)
R9	17000	1	potentiometer, W.W., 10K ohm, 10%
R10-R11-S3	18086	1	potentiometer, dual, 5K ohm, 500 ohm. w/SPST switch
R12	10448	1	resistor, 68 ohm, 1/2W, 10% (blue, grey, black, silver)
S1	60096	1	switch, rotary
S2	62016	1	switch, slide, DPDT
T1	30052	1	transformer, power
TB1	54013	1	terminal strip, 1 Post left with ground
TB2	54018	1	terminal strip, 4 Post with ground
TB3	54021	1	terminal strip, 2 Post upright left
V1	90002	1	tube, 6C4
V2	90058	1	tube, EM84/6FG6
XF1	97804	1	fuseholder, grey
XV1	97024	1	socket, tube, 7 pin miniature, bottom mount
XV2	97023	1	socket, tube, 9 pin miniature, bottom mount
	40000	12	nut, hex, No. 6-32
	40001	5	nut, hex, 3/8
	40007	11	nut, hex, No. 4-40
	40016	1	nut, hex, 1/2
	41086	8	screw, No. 6-32 x 5/16, binding head
	41047	2	screw, No. 8 self tapping
	41063	4	screw, No. 6-32 x 1/4, flat head
	41089	10	screw, No. 6-32 x 3/16, round head
	41090	8	screw, No. 4-40 x 5/16, binding head
	41091	3	screw, No. 4-40 x 1/4, flat head
	41113	3	screw, No. 4-40 x 1/4, flat head, Type F, self-tapping
	42000	5	washer, lock, 3/8
	42001	4	washer, flat, 3/8
	42002	12	washer, lock, No. 6
	42007	11	washer, lock, No. 4
	42005	4	washer, flat, No. 6
	42029	1	washer, rubber, 1/2"
	42511	1	retainer, spring indicator
	43001	2	lug, pot. solder, 3/8
	43006	2	lug, ground, No. 4
	46004	1	grommet, rubber, 5/8
	46013	4	foot, rubber
	51052	2	clip, crocodile
	53036	2	knob, 1-1/16" diameter
	53037	1	knob, 3/4" diameter
	53052	1	knob, 1-1/2" diameter
	56520	1	retainer, tube
	57004	1	line cord
	58400	length	cable, kinkless, black
	58404	length	cable, kinkless, red
	58405	length	cable, coaxial, 50 ohm, RG58A-7U
	80103	1	panel
	81322	1	chassis
	81323	1	bracket, tube
	82104	1	strain relief
	86005	1	frame
	87006	1	handle with rings
	88081	1	cabinet
	89260	1	label
	89525	1	sleeve, insulated rubber, red
	89526	2	sleeve, insulated rubber, black
	89649	2	bracket, handle
	89678	1	dial, plastic
	86104	1	manual of instruction (wired)
	66357	1	manual of construction (kit)

Service Policy

SECTION IV. EICO SERVICE POLICY

SERVICE CONSULTATION

If you are experiencing trouble that you cannot diagnose yourself, you are invited to avail yourself of the EICO Service Consultation Department. The consultant handling your inquiry will make every effort to diagnose the cause of your particular difficulty based on the information that you provide. Please be as thorough as possible. Include the following information about your unit:

- a) Have you made a thorough check of the wiring, checking also for cold solder joints, or accidental shorting between parts, or to chassis?
- b) Have you checked that the proper tube or transistor is in each socket, and also making proper contact in the socket? Are all shields firmly in place?
- c) Does the trouble occur at one time or one operating situation, but not at another time or operating situation? Be as specific as possible in this respect.
- d) If the unit is of the type that involves alignment or calibration, be as specific as possible as to what you have done or not done with regard to these requirements. If the unit incorporates tuned circuits stated to be factory pre-aligned, did you change any settings? If so, what alignment procedure did you use?
- e) Have you observed any peculiarity about a part? If a part appears charred or otherwise damaged by excessive heat, please say so. If you think you have damaged a particular part in the assembly or wiring, please say so. In conjunction with the symptoms, the consultant may be able to determine whether such a part is likely to be defective.
- f) Have you gone through any trouble-shooting procedure that may be provided? If your manual includes a table of contacts made at each switch position, have you checked out the switches accordingly (if the trouble is such that doing this would be appropriate)? Have you been able to make checks of the operating voltages and/or resistances, if this is appropriate, and your manual provides a table of voltages and resistances? What are the results of these checks? Also, have you taken any other trouble-shooting approaches? What have been the results?

In addition, list any code numbers in red under the words **INSTRUCTION MANUAL** on the cover of the book provided with your unit. If there are no red code

numbers, state this specifically. If the unit bears a serial number, it is essential that you include this also.

PARTS REPLACEMENT

If it appears that a component is defective, and you desire a replacement from EICO, address your correspondence to our Customer Service Department.

If you are claiming the right to a no-charge replacement under the terms and conditions of the warranty, it is required that you shall have sent in the registration card within 10 days of the date of purchase, and that you send back the defective part transportation prepaid. EICO will make the necessary replacement at no charge for parts eligible under the terms and conditions of the warranty. In returning tubes, pack them very carefully to avoid breakage in shipment. Broken tubes will not be replaced. Please read the warranty on the subject of parts eligible for replacement.

Further information required on a part returned to the factory for a no-charge replacement under the terms and conditions of the warranty is as follows:

- a) Model number and serial number, if any, of unit. Also any code numbers in red under the words **INSTRUCTION MANUAL** on the cover of the book supplied with the unit.
- b) Stock number and description of part as given on the parts list.
- c) Describe as completely as possible the nature of the defect, or your reason for requiring replacement.

FACTORY REPAIR SERVICE

EICO maintains a Factory Repair Service Department for in-warranty or out-of-warranty repair of EICO equipment. It is intended to serve those customers who are not adequately familiar with electronics to make use of the EICO Service Consultation facilities, or whose difficulties cannot be solved by correspondence.

For all out-of-warranty units, there is a minimum labor and handling fee. For the Model 955, this fee is \$7.50. Charges for components replaced are additional to the minimum fee.

For in-warranty completed kit units, there is a minimum labor and handling fee. For the Model 955, this fee is \$7.50. There is no charge for a replaced

defective part provided that the terms and conditions of the warranty for no charge replacement are not violated in the judgement of EICO.

For in-warranty factory-wired units, there is no labor and handling fee if the unit complies with the terms and conditions of the warranty in the judgement of EICO. However, if the terms and conditions of the warranty are violated, then there will be charged to customer a minimum labor and handling fee plus the cost of parts replaced.

In all cases, the unit must be sent to the factory transportation prepaid, and the unit will be returned to the customer transportation collect.

The services rendered for the minimum labor and handling fee are the correction of any minor wiring errors (not extensive corrections or re-wiring), the labor involved in replacing defective parts, and any adjustments, alignment, or calibration procedures that would normally be performed on a factory-wired unit. Units not wired according to instructions, or modified in any way, or showing evidence of the use of acid core solder, will not be serviced and will be returned to the customer forthwith.

Units requiring extensive corrections or re-wiring will incur an additional labor charge which will be set by EICO. The customer will be informed of this situation and written authorization from the customer will be required before the work is done.

Please note: minimum labor and handling fees are subject to revision at any time.

LOCAL REPAIR FACILITIES

Out-of-warranty repair work may also be performed by authorized service stations as well as the EICO factory. A list of authorized service stations is provided with this manual. The roster of stations may change from time to time, and if considerable time has elapsed since you purchased your unit, you are advised to contact the station you choose before sending the unit to them for repair. Use of a local service station will often result in faster service, and, usually, lower transportation costs.

It is necessary that you comply with the Shipping Instructions that follow when sending in a unit for service.

SHIPPING INSTRUCTIONS

You are strongly advised to retain the original shipping carton and inserts in the case that re-shipment is required for service or any other purpose. The carton may be collapsed, for storage in as small a space as possible. In very many cases, the same carton is used for kit and factory-wired units so that the kit carton will serve for re-shipment of the completed kit.

To submit a unit for service, either to the factory or an authorized service station, fill out completely the Service Work Order form provided with the manual.

Pack the unit very carefully, preferably in the original shipping carton with the original inserts.

If this is not possible, use a strong oversize carton, preferably wood, allowing at least 3 inches of resilient packing material such as shredded paper or excelsior, to be inserted between all sides of the unit and the carton. Seal the carton with strong gummed paper tape or strong twine, or both. Include the Service Work Order in the carton and in addition, attach a tag to the instrument on which is printed your name and address and brief reference to the trouble experienced. Affix "FRAGILE" or "HANDLE WITH CARE" labels to at least four sides of the carton, or print these words large and clear with a bright color crayon. Ship by prepaid Railway Express or parcel post to:

Customer Service
EICO Electronic Instrument Co., Inc
283 Malta Street
Brooklyn, New York 11207

Include your name and address on the outside of the carton. Return shipment will be made transportation charges collect. Note that a carrier cannot be held liable for damages in transit, if packing, IN HIS OPINION, is insufficient.

*Authorized service stations are for out-of-warranty units only, unless the station is specifically noted on the List of Authorized Service Stations to be authorized for other work.

EICO

THE EICO WARRANTY

EICO

The Electronic Instrument Company, Inc., hereafter referred to as EICO, warrants that, for a period of 90 days from the date of purchase, any EICO kit will be free of defects in parts, and that any EICO factory-wired unit will be free of defects in parts and workmanship. For an EICO kit, EICO's obligation is limited to those parts which are returned transportation prepaid to the factory without further damage, and in the judgement of EICO are either originally defective or have become defective in normal use. For an EICO factory-wired unit, EICO's obligation is limited to those parts, sections, or the entire unit which is returned transportation prepaid to the factory without further damage, and in the judgement of EICO are either originally defective or have become defective in normal use.

The warranty does not apply to any parts damaged in the course of handling, assembling, or wiring by the customer, or damaged due to abnormal usage or in violation of instructions or reasonable practice, or further damaged to a consequential degree to return shipment. Furthermore, the foregoing warranty is made only to the original customer, and is and shall be in lieu of all other warranties, whether expressed or implied, and of all other obligations or liabilities on the part of EICO, and in no event shall EICO be liable for any anticipated profits, consequential damages, loss of time, or other losses incurred by the customer in connection with the purchase or operation of EICO products or components thereof.

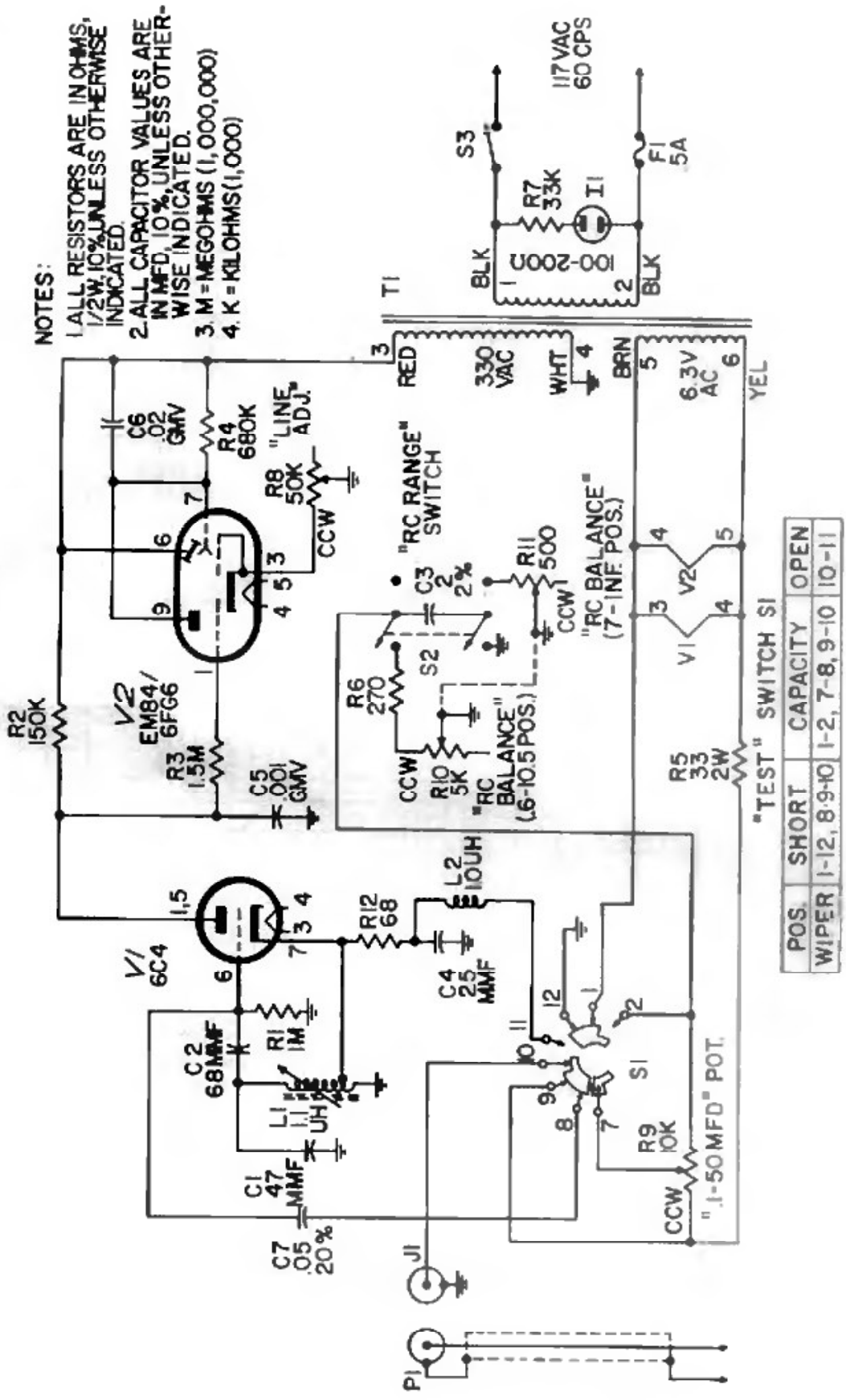
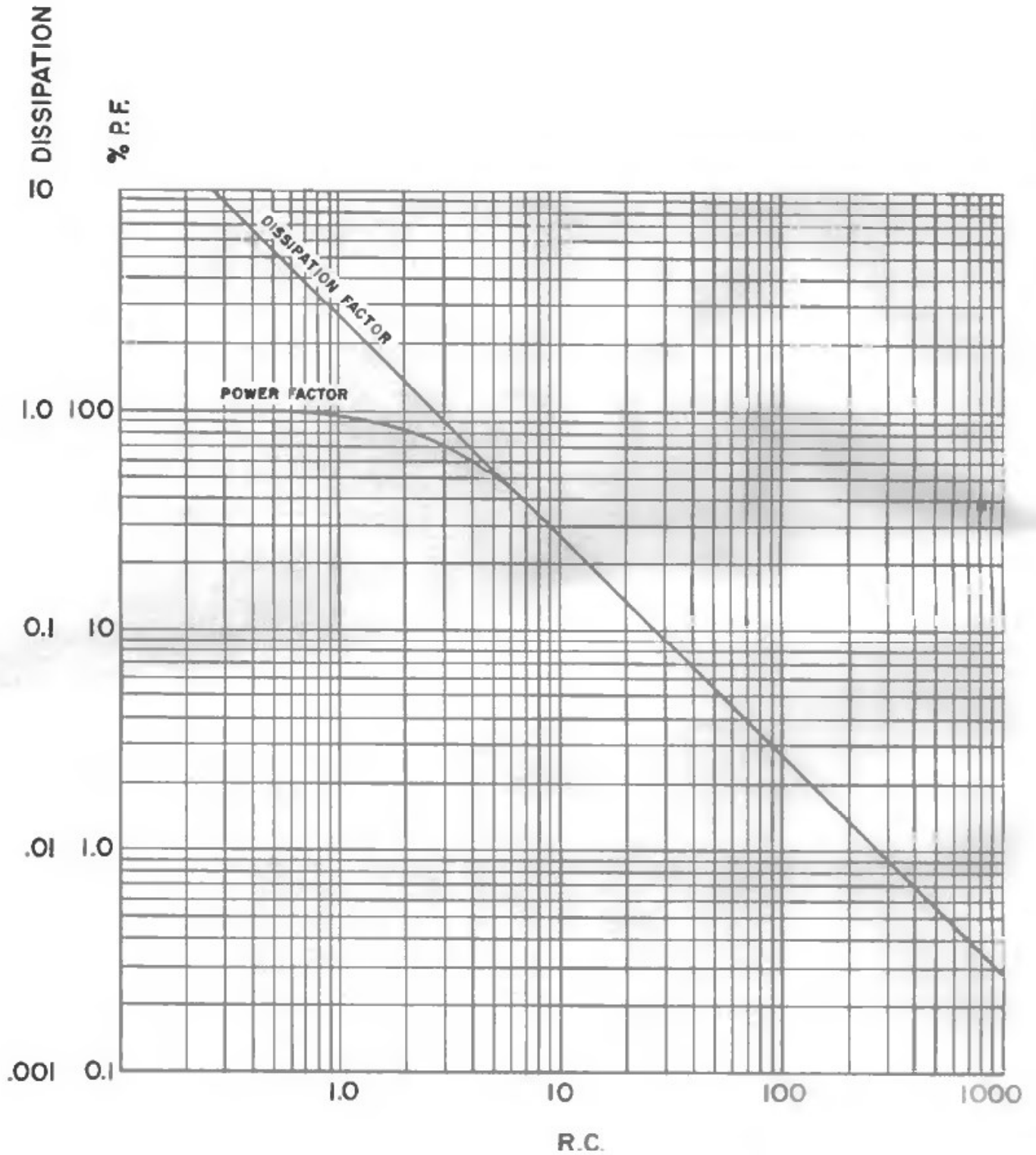

Fig. 4-2. Schematic Diagram w/Switching Table for 955



Graph: Dissipation and Power Factor vs. R.C.

MODEL 955-1 INSTRUCTION MANUAL ADDENDUM

Please make the following changes to your Instruction Manual:

Page 2: At the bottom of the page, change "*Patent Applied for" to "Patent no. 3,255,409".

Page 11, REPLACEMENT PARTS LIST

C3 20501 Amt. 1 Capacitor, paper, 2mfd, 150V Change 2% to 5%
C7 change 20001 paper to 20042 mylar capacitor
Change: 41089 Amt. 10 Screw, #6 - 32 X 3/16 round head
To: 41140 Amt. 10 Screw, #6 - 32 x 1/4 rd. hd., Phillips
self-threading
Change: 46013 foot, rubber to 46016foot, plastic.

51052 (clip, crocodile) should be 51502

Remove: 87006 Handle (1 required)
Add: 86548 assembly, handle and links (1 required)

Page 15, SCHEMATIC DIAGRAM:

C3 2mfd change 2% to 5%

If you have a kit, please make the following changes in your Construction Manual:

Page 10C Step 22: Change "paper capacitor" to "mylar cap."

Page 16C, Step 6: Change entire step as follows:

() 6. PRESS A (46016) PLASTIC FOOT, SLOTTED end first into each of the four holes in the bottom of the cabinet. SECURE each foot by pressing the small protruding plastic cylinder into foot so that slotted portion of foot expands and secures foot to cabinet.

Page 12, replacement parts list.
Change: 97804 Grey fuseholder
To: 97805 Black fuseholder

I.B. 2182

EICO ELECTRONIC INSTRUMENT CO., INC.
283 MALTA ST.
BROOKLYN, N.Y. 11207

EVERYTHING 4 LESS



ENJOY YOUR BOOKS



**PLEASE VISIT OUR STORE FOR EVEN MORE GREAT
STUFF!**

WWW.EVERYTHING4LESSSTORE.COM

COPYRIGHT NOTICE

**ALL MATERIALS INCLUDING CD/DVD AND PDF
FILES ARE COPYRIGHTED**

**WWW.EVERYTHING4LESSSTORE.COM VON
WALTHOUR PRODUCTIONS AND MAY NOT BE
REPRODUCED, COPIED OR RESOLD UNDER ANY
CIRCUMSTANCES. YOU MAY HOWEVER MAKE A
COPY FOR YOUR OWN PERSONAL BACKUP.
MATERIALS ARE FOR PERSONAL USE ONLY.**

**IF YOU PURCHASED THIS FROM ANYWHERE BUT
FROM US PLEASE NOTIFY US IMMEDIATELY SO
THAT WE MAY CHECK IF YOU PURCHASED FROM
AN AUTHORIZED RESELLER SO WE CAN LET YOU
KNOW IF YOU NEED TO RETURN FOR FULL REFUND
FROM AN UNAUTHORIZED SELLER.**

**THANKS AGAIN AND PLEASE TAKE THE TIME TO
VISIT OUR STORE.**

ATTENTION! EVERYTHING ON SALE NOW!!



HOT SALE!

**THIS PAGE COPYRIGHT VON WALTHOUR PRODUCTIONS
WWW.EVERYTHING4LESSSTORE.COM**