

INSTRUTEK

HOUMANNSGADE 41. 8700 HORSENS
TLF. (05) 62 71 77 - TELEX 6 16 56

OS250 10MHz
DUAL TRACE
OSCILLOSCOPE
Instruction Manual



ADVANCE

OS250 10MHz
DUAL TRACE
OSCILLOSCOPE

Instruction Manual



ADVANCE
INSTRUMENTS

Hainault Essex England

Telephone 01-500 1000

Telegrams Attenuate Ilford

Telex 263785

Division of ADVANCE ELECTRONICS LIMITED

Contents

SECTION 1	Introduction	3	4.9	Power supplies	11
SECTION 2	Specification	4	4.10	Calibrator	12
SECTION 3	Operation	5	4.11	Blanking	12
3.1	Switching on	5	4.12	Tube network	12
3.2	Obtaining a trace	5	SECTION 5	Maintenance	13
3.3	Setting up the Y channels	5	5.1	General	13
3.4	Single trace operation	5	5.2	Removal of sub-assemblies	13
3.5	Dual trace operation	5	5.3	Fault finding	13
3.6	Timebase and X expansion	5	5.4	Setting up procedure	14
3.7	X-Y mode	6	SECTION 6	Component Lists and Circuit Diagrams	17
3.8	Trigger	6	SECTION 7	Guarantee and Service Facilities	29
3.9	Additional facilities	6		ILLUSTRATIONS	
SECTION 4	Circuit Description	8	Fig. 1	Block diagram	8
4.1	General	8	Fig. 2	Transformer tap connections	13
4.2	The Y amplifiers	9	Fig. 3	Y amplifier circuit	19
4.3	The beam switch	10	Fig. 4	Timebase and X amplifier circuit	21
4.4	The trigger circuits	10	Fig. 5	Power supply circuit	23
4.5	The timebase bistable and ramp generator	10	Fig. 6	Interconnection diagram	25
4.6	Bright line circuit	11	Fig. 7	Top view	27
4.7	The X output amplifier	11	Fig. 8	Bottom view	28
4.8	X-Y mode	11			

The Advance OS250 Oscilloscope is a 10 MHz dual trace instrument with a 10cm x 8cm display. It is designed for use in general purpose laboratory work, educational uses, TV and servicing applications.

It features two identical input channels with a maximum sensitivity of 5mV/cm and a bandwidth of DC to 10MHz. The two channels may be viewed separately, alternately

at fast timebase speeds, or chopped at a 250kHz rate at low timebase speeds.

Particular attention has been paid to trigger performance, and the system used includes a variable control with bright line operation in the absence of a signal, or when the trigger level is outside the range of the input signal.

DISPLAY

5 in flat faced c.r.t. giving 10 cm X 8 cm display E.H.T. - 3.6 kV overall.

Phosphor-P31. Long persistence (P7) available as an option.

VERTICAL DEFLECTION

Two identical input channels. Y1 and Y2

Bandwidth (-3dB) DC-10MHz. (2Hz- 10MHz on AC)

Sensitivity 5mV/cm to 20V/cm in 1-2-5 sequence.

Accuracy ±5%.

Input Impedance 1 MΩ/approx. 28 pF.

Input coupling DC-GND-AC.

Protection 400V DC or pk AC.

DISPLAY MODES

Single Trace Y1 or Y2.

Dual Trace chopped or alternate modes, automatically selected on timebase switch. Chop rate approx. 250kHz.

X-Y mode with Y1 input giving X deflection and Y2 input giving Y deflection.

Bandwidth DC to 500kHz <3° phase shift at 20kHz.

HORIZONTAL DEFLECTION

Timebase-1μs/cm to 0.5s/cm in 18 ranges (1-2-5) sequences.

Accuracy ±5%.

X Expansion-X10 pull switch gives fastest speed of 100 ns/cm. Accuracy ± 5%

Variable control gives >2.5:1 reduction in sweep speed.

TRIGGER

Variable level control with option of bright line in absence of signal.

Trigger level control range

INTERNAL > 8cm

EXTERNAL > 20V

Source

Internal Y1 + or -

Y2 + or -

External + or -

External trigger input impedance, approx 100kΩ/10pF.

Coupling AC, AC fast, TV Frame.

Sensitivity

Internal	2mm approx. 40Hz-2MHz.	} bright line on or off.
External	1V approx. 40Hz-2MHz.	
Internal	1cm approx. 8Hz-10MHz.	} bright line off.
External	5V approx. 8Hz-10MHz.	
Internal	2cm pk/pk video on TVF	

ADDITIONAL FACILITIES

Calibrator 1 V ± 2% square wave at supply frequency.

Ramp output 0-10V.

Z mod input AC coupled. 10V gives visible modulation (2 Hz to 10MHz). 70V gives full blanking.

SUPPLY

95-111V, 103-121V, 111-130V. } 45-440Hz
190-222V, 206-242V, 222-260V. }
Approx. 25VA.

OPERATING TEMPERATURE RANGE

0-50°C (15°C to 35°C for full accuracy, approx 2% degradation at 0°C and 50°C)

DIMENSIONS

18cm (7") X 29cm (11³/₈") X 42cm (16¹/₂")
Approx. 7 kg (15 lbs.).

ACCESSORIES

Connector BNC - BNC PL43

Connector BNC - clips PL44

OPTIONAL ACCESSORIES

Probe Kit PN 32824. A passive probe kit with X1 and X10 attenuations. With X10 attenuation input impedance is 10MΩ/13.5pF.

Viewing Hood PN A1/32264.

Trolley Type TR4 A general purpose oscilloscope trolley.

Protective Carrying Case PN 3247.

A strong carrying case which completely encloses the oscilloscope with three thicknesses of padded material covering the front panel.

Tube Option The OS250 may be ordered with a long persistence c.r.t. (P7 phosphor).

Rack Mount Kit PN 33389

Adaptor BNC-binding post PN 26234

3.1 SWITCHING ON

CAUTION The OS250 relies on convection cooling and must always be operated in a position such that external air circulation is not restricted.

1. Set the support/carrying handle to the required operating position. The handle is released by pulling both fixing bushes outward, and it can then be turned to lock in any one of 5 positions.
2. Check that the supply transformer taps are wired correctly for the supply and that the corresponding supply fuse is fitted (see section 5.1)
3. Turn the BRILL control clockwise beyond the OFF setting and ensure that the indicator lamp lights.

3.2 OBTAINING A TRACE

1. To obtain a trace
 - (a) Set the Y1 shift control to approximately mid setting
 - (b) Set the Y2 shift control to Y2 OFF.
 - (c) Set the X shift control to approximately mid setting.
 - (d) Set the TRIG level Control to normal position i.e. not pulled out for BRIGHT LINE OFF
 - (e) Set the TIME/CM switch to $5\mu\text{s}$
 - (f) Adjust the BRILL control to obtain a display of the required brightness.
 - (g) Centralise the display by adjusting the Y1 and X shift controls.
 - (h) Adjust the FOCUS control to obtain a sharply defined trace.

3.3 SETTING UP THE Y CHANNELS

1. Using one of the coaxial input signal leads (PL43 or PL44), connect a signal to the Y1 or Y2 input socket.
2. For
 - (a) Direct connection of the input signal, set the associated AC-Ground-DC input slide switch to DC.
 - (b) Capacitive coupling of the input signal through an internal $0.1\mu\text{F}$ 400V capacitor, set the slide switch to AC.

NOTE When examining low amplitude a.c. signals super-imposed on a high d.c. level, the slide switch should be set to AC and the sensitivity of the Y amplifier increased as in (4).

3. To locate the baseline, set the slide switch to the 'ground' setting. At this setting, the input signal is open circuit and the input of the amplifier is switched to ground.
4. To select the sensitivity, set the VOLTS/CM switch to the required range. To minimise pick up at sensitive settings, it is essential to ensure

that the ground lead connection is near to the signal point.

5. For vertical shift of the trace, adjust the Y shift controls (identified with vertical arrows).
6. Any trace movement under no signal conditions, when the setting of the VOLTS/CM switch is altered, can be minimised by adjustment of the BAL preset control.

NOTE This control will only need adjustment at infrequent intervals. Before adjusting the BAL preset control ensure that the input slide switch is set to the 'ground' setting.

3.4 SINGLE TRACE

1. For single trace operation on the Y1 channel, set
 - (a) The Y1 shift control beyond the Y1 OFF setting.
 - (b) The Y2 shift control to Y2 OFF.
2. For single trace operation on the Y2 channel, set
 - (a) The Y2 shift control beyond the Y2 Off setting.
 - (b) The Y1 shift control to Y1 OFF.

3.5 DUAL TRACE OPERATION

In the dual trace condition, the beam switching function is in operation and results in independent display of two signals simultaneously. Two modes of beam switching – chopped and alternate – are used, and automatically selected by the setting of the TIME/CM switch. At any fast setting from $1\mu\text{s}$ to 0.5ms, inclusive, the alternate switching mode is in operation. At slow settings from 1ms to 0.5s inclusive, the chopped switching mode is in operation.

For dual trace operation, set:

- (a) The Y1 shift control beyond the Y1 OFF position.
- (b) The Y2 shift control beyond the Y2 OFF position.

3.6 TIMEBASE AND X EXPANSION

The sweep speed of the internal timebase (i.e. the time scale of the horizontal axis) is determined by the setting of the TIME/CM switch. The setting of the switch automatically determines which mode of beam switching is used during dual trace operation. In addition to selection of the speed of the internal timebase, the switch has one further setting, X-Y, at which the internal timebase is inoperative.

1. To adjust the time scale of the horizontal axis:
 - (a) Set the TIME/CM switch to a suitable setting.
 - (b) If necessary, adjust the uncalibrated VARIABLE control.

NOTE The range of the VARIABLE control is approximately 3:1. Except at the CAL setting, the VARIABLE control is uncalibrated. At the CAL setting, the calibration corresponds to the setting of the TIME/CM switch.

2. For horizontal shift of the trace, adjust the X shift control (identified by horizontal arrow).
3. If close examination of any portion of the trace is required, operate the PULL X10 control. This facility is available at all settings except X-Y of the TIME/CM switch, and effectively increases the sweep length from 10cm to 100cm. Any portion of the increased sweep length may be selected for viewing on the display by use of the X shift control.

3.7 X - Y MODE

When the TIME/CM switch is set to X-Y, the Y1 input channel is switched to the X amplifier. Under this condition, an external signal applied to the X (Y1) socket is routed through the input attenuators in the Y1 channel, and the full range of the sensitivity may be utilised to obtain a calibrated horizontal deflection. Only single trace operation (Y2 channel) is possible. In this mode, the Y1 shift control is inoperative and X shift is effected by the X shift control. The X bandwidth is limited to 500 kHz and thus the relative phase shift between X and Y is significant only above 20 kHz.

3.8 TRIGGER

The timebase may be triggered from the positive or negative slope of the signal selected by the TRIG SELECT switch as follows:-

- (a) Y1 or Y2 signal (irrespective of which beam is displayed).
- (b) An external triggering source connected to the EXT TRIG socket.

When the LEVEL control is pulled out to select BRIGHT LINE OFF, the timebase will only trigger when the trigger signal reaches the selected level. When the LEVEL control is set outside the range of signal or when there is insufficient signal amplitude the timebase will not run and the screen will remain blank.

The more normal mode of operation is with the LEVEL control pushed in, when the timebase will free run in the absence of the correct trigger to display a bright line or unsynchronised display until the level control is adjusted and/or the amplitude of the trigger signal is increased. This free run action in the absence of correct trigger helps in finding the trace and leads to ease of operation. If the timebase is required to free run continuously, the LEVEL control should be set to either end of its rotation.

It is expected that the BRIGHT LINE OFF mode will be selected only when the instrument is to be used to display signals at low or high repetition rates.

- * The TRIG SELECT switch is used in conjunction with the ACF-AC-TVF slide switch. This switch connects different networks into the trigger amplifier circuit and is effective at all settings of the TRIG SELECT switch. The operating facilities available at the three settings of the slide switch are as follows:-

- AC Wideband trigger mode used for most signals.
- ACF A filter is switched into circuit to reject low frequencies. High frequency triggering may be effected from complex waveforms such as those with high ripple content or line triggering from a television video signal waveform.
- TVF A filter is switched into circuit to reject high frequencies. Its cut off is chosen to accept the frame synch of a TV video waveform and reject the line frequency component.

Summarising, triggering control is effected as follows.

1. Set the TRIG SELECT switch to select the required trigger signal and slope.
2. Set the ACF-AC-TVF switch to the required setting.
3. Adjust the LEVEL control so that the trace starts at the required point on the waveform.

3.9 ADDITIONAL FACILITIES

(a) Cal

This socket provides a d.c. coupled positive-going square wave of $1V \pm 2\%$ amplitude at line frequency for calibration checks. The square wave has a source impedance of $1k\Omega$ and a risetime of approximately $20\mu s$ suitable for probe compensation.

(b) Ramp

This socket on the front panel provides a d.c. coupled positive-going timing ramp of approximately 10V amplitude generated by the timebase. Source impedance is $18k\Omega$.

(c) Z Mod

The socket on the rear panel allows an a.c. coupled signal to modulate the brightness. Coupling is by an internal $0.02\mu F$ capacitor into $4.7M\Omega$. The input impedance at this socket is $100k\Omega$. (2Hz-10 MHz)

1. Sensitivity is approximately 10V pk-pk for visible modulation at normal brightness.
2. Full blanking requires a 70V negative-going pulse.

(d) Use of Optional Passive Probe

A X10 passive probe may be used to extend the voltage range and increase the input impedance of the Y amplifiers. The input resistance of a Y channel is $1M\Omega$, shunted by approximately 28pF. The effec-

* See OS250 TV Supplement.

tive capacity of the input lead must be added to this and the resultant impedance can often load the signal source. Therefore it is advisable to use a $10M\Omega$ X10 probe such as Advance PN32824. This reduces the input capacity and increases the input resistance, at the expense of a 10X reduction in sensitivity. The probe contains a shunt RC network in series with the input and forms an attenuator with the input RC of the Y channel. To obtain a flat frequency response it is necessary to adjust the capacitance of the probe to match the input capacity of the Y channel as follows:

1. Set the Y channel VOLTS/CM switch to 20mV, the TIME/CM switch to 1ms and TRIG INT POS from the appropriate channel.

2. Connect the probe to the CAL socket.
3. Adjust the probe compensation to obtain a level trace, i.e. flat top without overshoot or undershoot over the first few milliseconds of the 50Hz waveform.

(e) **Camera**

A camera may be fitted to the oscilloscope to record waveforms. This facility is particularly useful for the slow speed timebase settings. Suitable cameras utilising Polaroid or 35mm film may be obtained from D. Shackman & Sons, Polaroid Ltd., or Telford Products Ltd. Adaptors are available for attaching the camera to the oscilloscope. Other oscilloscope cameras may be used but suitable adaptors must be obtained and should be discussed with the camera manufacturer.

The OS250 block diagram is shown in Fig. 1. Inter connection of the printed circuit boards, controls, tube and associated components is shown in Fig. 6. Circuit diagrams are as follows:-

Fig. 3 Y1 and Y2 attenuators, pre-amplifiers, the main Y amplifier, beam switch and drive circuits.

Fig. 4 Timebase, X amplifier and trigger circuits.

Fig. 5 The power supply and tube network.

4.1 GENERAL

Referring to the block diagram (Fig.1) signals applied to the Y1 and Y2 input sockets pass into their respective attenuators and amplifiers. The VOLTS/CM switch controls the gain of the amplifier in the necessary 1 . 2. 5 sequence to cover the ranges from 5mV/cm to 0.2V/cm. Above this a $\div 100$ attenuator is introduced before the amplifier.

The fast electronic beam switch selects either the Y1 or the Y2 signal to be amplified further and passed to the Y deflection plates of the c.r.t.

A sample of each signal is taken and passed to the trigger switch, where selection of Y1, Y2 or Ext trig source is made. The selected signal is amplified and passed to the Schmitt trigger, where it is converted into fast negative-going pulses. The hold off circuit acts as a gate which is normally open to allow a trigger pulse to set the timebase bistable. The bootstrap ramp generator then begins to generate its

linear ramp, which after passing through the X amplifier is applied to the cathode ray tube and drives the electron beam linearly across the tube face. A small portion of the signal from the ramp generator is fed back to the hold off circuit, shutting the gate to prevent any further pulses from the Schmitt trigger from reaching the timebase bistable during the ramp period. When the ramp has reached the necessary maximum level, the timebase bistable is reset, and the ramp is quickly returned to its quiescent state. A time constant in the hold off circuit now holds the gate closed to inhibit another ramp from being initiated for a short period, until the ramp timing capacitor is discharged fully. Thus a ramp is generated at a rate set by the TIME/CM switch when the trigger signal reaches a predetermined level. This ramp sweeps the beam across the c.r.t. face, returns and waits for the next trigger point to be reached. The timebase bistable is connected to a blanking amplifier whose function is to turn on the electron beam during the sweep and blank it off during the fly back and subsequent waiting period.

At fast sweep rates for a dual trace display, the TIME/CM switch automatically selects the alternate sweep mode of control for the beam switch. At the end of each sweep the signal from the time-base bistable reverses the state of the beam switch bistable, causing alternate displays of the Y1 and Y2 signal on successive sweeps of the timebase. At slow sweep rates, the chop mode is selected, when the chop

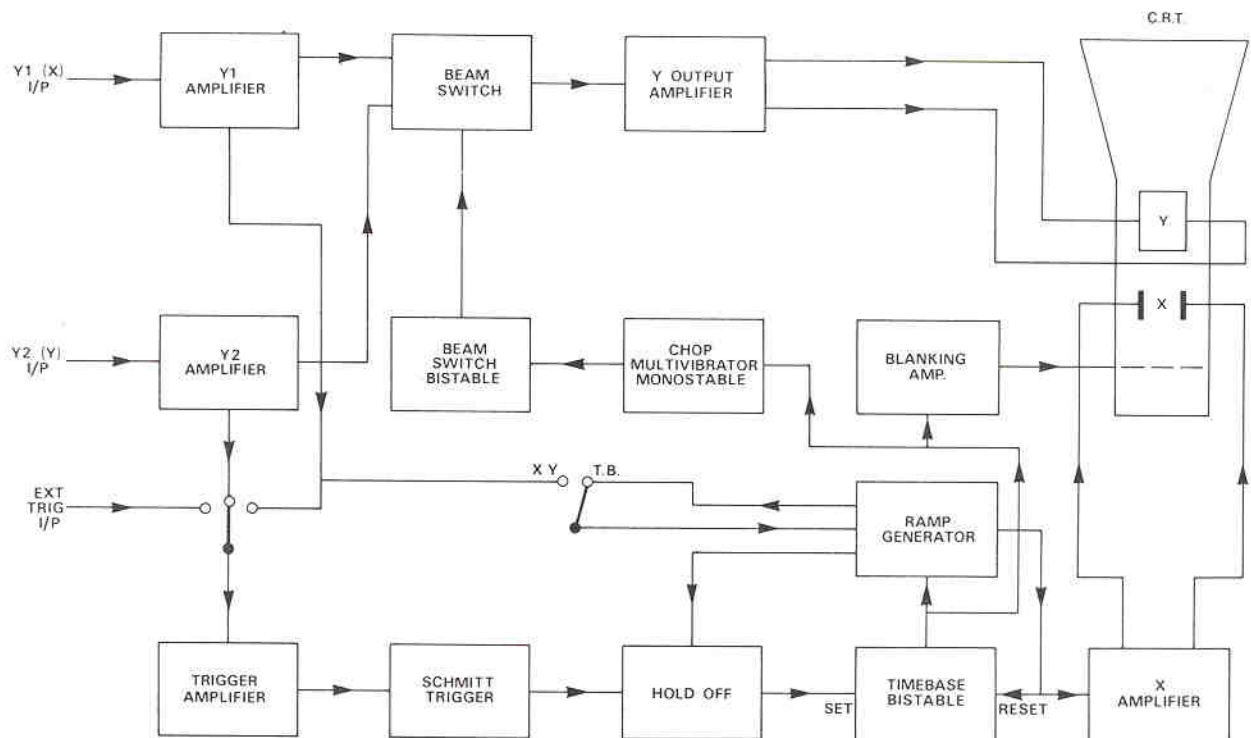

Fig. 1 Block diagram

multivibrator free runs independently, causing the beam to switch between Y1 and Y2 levels during the sweep. A signal from the multivibrator also blanks the trace during each switching transition. With Y1 or Y2 switched to the OFF position the beam switch bistable is locked to switch on the other channel.

In the X-Y mode, the signal from the Y1 amplifier, normally used for trigger, is passed via the ramp generator, which acts as a voltage follower, to drive the X plates while the beam switch selects Y2 to drive the Y plates. The beam blanking signal is not used.

4.2 THE Y AMPLIFIERS

The attenuator and pre-amplifier in the Y1 channel are identical to those in the Y2 channel. Accordingly, only the Y1 channel is described.

The input signal is applied to the front panel socket SKA and then to the 3 position slide switch S20, via R26. The switch selects AC or DC input coupling by including or by-passing C21 in the signal path. In the middle position of the switch, the input socket is disconnected, and the input of the attenuator is connected to ground through R27. The attenuator feeds into an impedance of $1M\Omega$ (R29). The $\div 100$ attenuation is determined by the potential divider action of R20 in series with the parallel combination of R29 and R201. High frequency compensation of the attenuator is achieved by the a.c. potential divider C202 and C203; C202 is set for the correct ratio. C201 is adjusted to maintain constant input capacitance between divided and undivided ranges. This attenuator is used on the six higher voltage ranges i.e. 0.5V/cm – 20V/cm, dividing them down to 5–200mV/cm. Further selection of input sensitivity is carried out by gain switching within the amplifier, and is described later. Diodes D201 and D202 in conjunction with R28 protect the input up to 400 volts peak.

The input stage consists of TR201 and TR202, a matched pair of field effect transistors. The current in TR202 is self biased such that the potential drop across R205 equals the gate/source potential. This same current flows in TR201, which operates as a source follower on the input signal. As R207 equals R205 the base potential of TR203 always equals the input voltage on the gate of TR201. The signal is passed via emitter follower TR203 to the gain switching stage.

The grounded emitter transistor TR204 forms a shunt feedback amplifier with gain determined by the ratio of the feedback resistor R211 to the input resistor R40 in parallel with the resistor selected by the range switch as shown in Table 1. R202 (BALANCE) sets the base of TR203 to null the potential across R40 etc.

The signal from the collector of TR204 is passed via R214 to the base of TR205 which in conjunction with TR206 forms a long tail pair amplifier, the gain of which

Table 1.

Switch Setting	Attenuation	Resistor Used	Amplifier Gain
5mV	$\div 1$	R40+R45	5
10mV	$\div 1$	R40+R44	2.5
20mV	$\div 1$	R40+R43	1.25
50mV	$\div 1$	R40+R42	0.5
100mV	$\div 1$	R40+R41	0.25
200mV	$\div 1$	R40 only	0.125
500mV	$\div 100$	R40+R45	5
1V	$\div 100$	R40+R44	2.5
2V	$\div 100$	R40+R43	1.25
5V	$\div 100$	R40+R42	0.5
10V	$\div 100$	R40+R41	0.25
20V	$\div 100$	R40+ only	0.125

is set by R217 and R223. The collector current of TR205 feeds into the trigger section of the timebase and 'X' amplifier circuit (fig.4). Potentiometer R52 provides a variable current via R219 into the collector circuit of TR206, to produce 'Y' shift. The bases of TR206 (Y1) and TR216 (Y2) are driven from the collector circuit of TR217 which being connected in a similar manner to TR204 and TR214 provides the correct bias and compensation for supply and temperature variations.

The beam switch, consists of diodes D203, D204, D206 and D207, with their associated drive circuitry and is described in detail in section 4.3. It selects the collector current of TR206 or of TR216 to pass through D205 and R223. The voltage developed across R223 consists of a fixed d.c. component, a variable d.c. component (Y shift) and the signal and is applied to the base of TR207, a common emitter amplifier. The emitter circuit includes potentiometer R222, to set the gain of the stage and hence the overall gain of the amplifier. The signal from the collector of TR207 is passed to the base of TR208, which with TR209, TR210 and TR211 forms the output cascode stage. TR208 and TR209, is a long-tail pair, which converts the input signal voltage to differential output current; its gain is determined by emitter resistors R234 and R236, with high frequency gain set by networks R232/C211/C212, R233/C213 and R236/C236. The collector currents of TR208 and TR209 flow into the emitters of the grounded base transistors TR210 and TR211 to develop the differential output voltage across the load resistors R230/R240 to drive the c.r.t. deflection plates. Inductors L201 and L202 are included to improve the high frequency response.

4.3 THE BEAM SWITCH

The cathode of D203 is supplied with a 6 volt positive-going square wave from the bistable TR218/TR219. When the waveform is "high", D203 is biased off and the collector current of TR206 passes through D204 into the output amplifier. During the low state of the waveform D203 conducts, passing this current to ground through TR219. As diodes D203 and D207 are fed with complimentary waveforms, when the current from TR206 passes to the output amplifier, that from TR216 is shunted to ground and vice-versa.

Bistable TR218/TR219 is switched with pulses from TR220/TR221, the chop multivibrator.

This emitter coupled circuit free runs at approx. 500kHz on TIME/CM settings from 0.5s to 1ms,[†] causing the bistable to operate the beam switch at 250kHz. In addition to driving the bistable, an output from the collector of TR221 is fed to the cathode of the c.r.t. to blank the trace during the beam switching transitions. The mark/space ratio of the multivibrator is approx. 1:4, causing the trace to be blanked for one fifth of each switching period.

At faster TIME/CM settings of 0.5ms^{††} to 1 μ s, the lower end of R292 is taken to -20V by a contact on the timebase switch biasing off TR221, and preventing oscillation. The circuit now acts as a monostable, triggered via C220 at the end of each sweep by pulses from the timebase bistable, each output pulse reversing the beam switch bistable and rapidly blanking the trace.

For single trace operation, the Y shift control on the channel not required is rotated fully anti-clockwise to operate the OFF switch. In this position, the switch S27 or S28 is closed, connecting the cathode of its associated diode to the negative line. This biases off the relevant transistor in the bistable. Thus when Y1 is turned off, S27 closes, biasing off TR218; TR219 turns on and sinks the current from Y1 channel to ground through D203. A reversal occurs when Y2 is turned off. In the X-Y mode, both shift controls are set to the on position; a contact on the TIME/CM switch in parallel with S27 is used to bias TR218 off, allowing Y2 signals only to reach the Y output stage.

* 4.4 THE TRIGGER CIRCUITS (Fig. 4)

The collector currents from TR205 and TR215 in the Y amplifier pass to the timebase printed circuit board into R108 and R109 respectively. In series with R108 is R110 shunted by C101, a collector load network used when X-Y mode is selected. External trigger signals appear across R107, and these, together with those across R108 and R109 pass to the trigger selector switch. The selected trigger signal is amplified by TR107 and passed to the coupling switch. Here, high pass, direct

and low pass networks provide the required ACF-AC-TVF filtering. Trigger level and slope selection operations are performed by long-tail pair amplifier TR101/TR102. The signal is applied to either input as determined by the slope selector switch, the other input being grounded via C121. The Trigger Level control, R10, provides a variable d.c. bias at both inputs, which the amplifier sums with the signal. The output at the collector of TR102, consisting of an alternating signal voltage superimposed on a d.c. level, passes to the Schmitt Trigger TR103/TR104, where fast negative edges are generated as the input signal crosses the circuit threshold.

4.5 THE TIMEBASE BISTABLE AND RAMP GENERATOR

The ramp generator comprises TR111, TR112 and TR113 as cascaded emitter follower stages, with bootstrap feedback action provided from the cathode of Zener diode D104. This feedback maintains constant voltage across the VARIABLE TIME control R11, R148, R147 and the timing resistor selected by the TIME/CM switch. This constant voltage drop, independent of actual voltage level produces a constant current to linearly charge the timing capacitor, also selected by the TIME/CM switch. The VARIABLE TIME control provides fine adjustment of the timing current, and hence sweep time, by varying the feedback voltage applied to the timing resistor.

In the quiescent condition of the timebase bistable, TR108 is on, TR109 is off and clamp transistor TR110, which shunts the timing capacitor, is saturated. A negative-going pulse from the Schmitt Trigger is coupled via C111 and D102 to turn off TR108. TR109 turns on, thus turning off TR110. The clamp is removed, allowing the timing capacitor to charge, producing the linear ramp. As the emitter of TR113 rises, a feedback voltage, via D105, R143 and R133 biases off D102 to prevent any further pulses reaching the bistable. Connected to the junction of R133/R143 is the HOLD OFF capacitor which now charges positive. When the ramp reaches its final amplitude, a rise of approximately 10V, feedback from the junction of R151/R149 is applied to the base of TR108, turning it on. The bistable reverts to its initial state allowing TR110 to turn on, rapidly discharging the timing capacitor and returning the ramp to its quiescent level. The hold off capacitor, which was charged to a positive voltage during the ramp, now slowly discharges through R143 and R153, until it is caught by D105. Only then is D102 biased for the next trigger pulse to initiate the next sweep.

An output is taken from the ramp generator via R155 to SKE, the RAMP OUT socket, on the front panel.

† 2ms. on OS250TV.

†† 1ms. on OS250TV.

* See OS250TV Supplement.

4.6 BRIGHT LINE CIRCUIT

When sufficient trigger signal is available, the square wave from the collector of TR104 passes through R127/C104, where restoration by D101 produces a negative going signal with respect to the negative rail. This negative signal on the base of TR105 is integrated by R124/C107 to produce a d.c. bias sufficient to hold off TR106. In this condition the circuit has no effect on timebase operation. However, when the triggering signal falls below the required level, the Schmitt trigger ceases to operate, removing the signal from D101. The voltage on the emitter of TR105 rises to approximately one volt above the negative line, turning on TR106. R177 is now effectively connected between the negative rail and the cathode of D102. It rapidly discharges the hold off capacitor below the normal quiescent level to a point where D102 conducts, turning TR108 off and initiating a sweep. At the end of the ramp, the charge on the hold off capacitor is again removed by R177/R143 and another ramp begins. These consecutive sweeps produce the bright line display. When the "PULL BRIGHT LINE OFF" control is operated, switch S10 closes, effectively shorting the base and emitter of TR106, holding it off; in this condition a ramp is only generated after the arrival of a trigger pulse.

4.7 THE X OUTPUT AMPLIFIER

The ramp or X-Y signal at the emitter of TR113 passes through R156 to the base of TR114, which with TR117 forms a long tail pair. Gain switching is carried out in the emitter circuit by selection of one of two resistance paths, with gains set by R169(X1) and R16 R162(X10). In timebase mode, the PULL X10 switch S11 can be operated in order to expand the trace length ten times. In the X-Y mode contacts on the TIME/CM switch, in parallel with S11, close to select this higher gain setting automatically. An X SHIFT voltage is produced at the base of TR117 by R12. The signals on the collectors of TR111 and TR117 are applied to the differential output amplifier, TR115 and TR116. Signals from the collectors of these two transistors drive the horizontal deflection plates of the c.r.t.

4.8 X-Y Mode

In this mode, signals are applied to both Y1 and Y2 input sockets; Y2 is routed through the beam switch to the Y deflection plates in the normal manner. Y1 is routed through the ramp generator, now acting as a high impedance unity gain buffer, and into the X output stage.

Signals entering Y1 channel pass through the attenuator and gain switching stage, as described previously. Current from TR105 passes to the X board, while that in TR206 is shunted to ground through D203. The current from TR205 develops a voltage across the series connection of

R110, R108. This voltage is level-shifted by R144/R146 to the base of TR111. In the X-Y mode, both timing resistors and capacitors are switched out of circuit, consequently TR111, TR112 and TR113 merely act as emitter followers which provide buffering between the level-shift resistors and the X output amplifier.

When this mode is selected, a contact on the TIME/CM S14(a) switch connects the cathodes of D106 and D107 to the negative line. The current drawn through D106 and R138 turns off TR108 and consequently TR110, and removes blanking. (See section 4.11)

Current through D107 controls the state of the beam switch bistable. (See section 4.3)

4.9 POWER SUPPLIES (Fig. 5)

All power supplies are derived from transformer T1. The primary winding can be connected to accept six supply voltage ranges, as shown in fig. 2, on the inside of the top cover.

The transformer secondary has four windings developing the following r.m.s. voltages; 6.3V, 44V (centre tapped), 140V and 1000V.

The 6.3V winding supplies the c.r.t. heater.

The 44V a.c. is rectified by MR32 and smoothed by C33/C34 to form the unstabilised +26V and -26V d.c. lines. These voltages are fed to series regulators to provide the stabilised +20V and -20V lines. As both regulators operate in an identical manner, only one will be described.

The base of series pass transistor, TR32, is fed from the output of the high gain error amplifier formed by TR305/TR306. This amplifier compares the zener reference voltage from D316 with the voltage at the junction of R310/311, a potential divider connected between the emitter of TR32 and ground. As this emitter supplies the +20V line, any fluctuations in the line voltage appear at the base of TR306 where they are amplified and inverted. This signal is then fed to the base of TR32 to correct the error, thus maintaining a constant output voltage. Resistor R309, in series with the collector of TR32, drops a voltage which is proportional to the output current. Under normal conditions, this voltage drop is less than that across R307, biasing off D310. As the output current rises above the safe maximum, D310 turns on, taking the current in R307 away from the emitter of TR305. This causes a drop in voltage at the collector of TR306 and hence on the base and emitter of TR32, limiting the current to a safe value.

The voltage from the 140V winding is rectified by MR31 and smoothed by C31 to form the unstabilised 170V line.

The 1000V winding energises both the -1.2kV and $+2.4\text{kV}$ supplies. Half wave rectification of the negative half cycle by D301 produces the negative line, while voltage doubling by D302/D303 produces the positive. Stabilisation of both lines against supply variation is achieved as follows. One end of the 1000V winding feeds the diodes mentioned above. The other end passes to ground through bridge rectifier MR301. The alternating current in the winding passes through the rectifier as direct current via R338 and TR301, developing a smooth direct voltage across C315. This voltage, controlled by the conduction of TR301, forms a threshold above which the alternating voltage applied to the bridge must rise before current can flow. As this threshold must be reached on both positive and negative excursions of the supply waveform, the overall effect is to take the middle out of the sine wave, thus reducing its voltage. This controlled voltage is rectified to produce the E.H.T. supplies. R322 feeds a negative current into the base of TR302, proportion to the peak value of the regulated waveform. This current is balanced by a reference current from the + line fed via R319 and SET E.H.T. potentiometer R320. The voltage at the summing point of the two currents appears at the emitter of TR302 and controls the current flow through D304, which in turn controls the conduction of TR301. As it is this conduction which controls the alternating voltage from which the feedback is derived, a closed loop circuit is formed. Variations in the magnitude of voltage across the 1000V winding either increases or decreases the voltage on the -1.2kV line. Feedback from this line is compared with a reference and the conduction of TR301 is varied accordingly to bring the line back to its correct voltage. As the $+2.4\text{kV}$ line is derived from the same stabilised source as the -1.2kV , it also remains constant.

4.10 CALIBRATOR (Fig. 5)

The $1\text{V} \pm 2\%$ square wave at the CAL 1V socket, SKD, is produced by TR307, on the power supply board. Current for the base of this transistor is supplied via R305 and D311. The anode of D312, is connected to the junction of these two components, its cathode being taken to one of the 22V windings. On positive excursions of the winding, D312 is biased off, and the current through R305, D311 saturates TR307. During negative excursions, D312 conducts, and the current in R305 passes through the transformer winding. In this condition

D311 and TR307 are turned off. The result is a square wave on the collector of TR307, at line frequency, with amplitude set by adjustment of R304.

4.11 BLANKING

The signal which blanks the c.r.t. when a sweep is not occurring is produced by TR308. The base of this transistor is fed via R135/C118 from the collector of TR108 in the timebase bistable. When TR108 is on, no current flows in R135, thus TR308 is off and its collector is at approximately 70V, as determined by R335, R336 and R337. This voltage is fed to the beam blanking plates of the c.r.t., pin 5, and blanks the trace. As TR108 turns off to initiate a sweep, the current in R135 turns TR308 on; its collector voltage falls to about 3V, where it is held by the action of the forward biased diode, D313. Under this condition c.r.t. blanking is removed. Blanking is not effected in the X-Y mode as TR108 in the timebase bistable is permanently off.

When dual trace operation is selected, a pulse is coupled via C314, from the collector of TR221 into the cathode of the c.r.t. in order to blank the trace during the switching transition.

Z Modulation

Signals applied to SKF on the rear panel pass via C313 to the grid of the c.r.t. where they produce trace intensity modulation.

4.12 TUBE NETWORK

The cathode of the c.r.t. draws current from the -1.2kV line through the BRILLIANCE control, R33. Clockwise rotation of this control decreases the grid potential, and hence varies the tube conduction from cut off to maximum. Electrons emitted from the cathode are focussed into a narrow beam by potentials on the focus and astigmatism electrodes. These potentials are approximately -850V and $+80\text{V}$, controlled by R34 and R332 respectively.

When a positive potential is applied to the blanking plates, the electron beam is deflected to one side of the tube, thus preventing the electrons striking the tube face. The geometry control R333 varies the potential on an electrostatic shield placed between the X and Y deflector plates to minimise interaction. After deflection by the X and Y plates, the electron beam is accelerated by the PDA potential of $+2.4\text{kV}$, to strike the phosphor coated tube face at high velocity, and produce a display.

5.1 GENERAL

Figs 7 and 8 show the internal location of sub assemblies and preset controls. Access to all preset controls and most other components is obtained by removing the top and bottom covers. Full access to all components can be achieved by removing the Y amplifier sub assembly or timebase and X amplifier sub-assembly. For detailed fault finding the instrument can be operated with either assembly out of the frame and with the interconnecting leads extended.

(a) Removal of Covers

Each cover is retained in position by four latch fasteners. Each fastener is released by turning it one quarter of a turn counter-clockwise.

(b) Transformer Tap connections

DISCONNECT THE INSTRUMENT FROM THE SUPPLY BEFORE ADJUSTING THE TRANSFORMER TAPS. The transformer tap connections for each of the normal supply voltages are shown in fig 2 below. This diagram is reproduced inside the top cover of the instrument. It will be seen that the two tapped primary windings are connected in series or parallel as necessary. The 'line' is the brown lead from the fuse and the 'neutral' is blue. Check that the correct fuse is fitted for the supply in use.

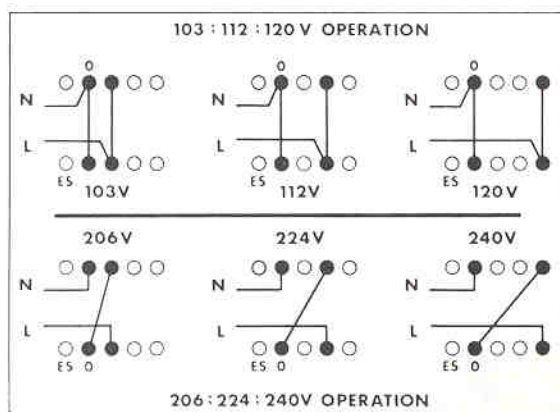

Fig. 2 Transformer tap connections

(c) Fuse Replacement

DISCONNECT THE INSTRUMENT FROM THE SUPPLY BEFORE CHANGING THE FUSE. The size 0 fuse is mounted on the rear panel, above the transformer. For 190-260V operation, a 200 mA slow blow fuse, Advance Part No. 24041 is required. For 95-130 volt operation, a 400mA slow blow fuse, Advance Part No. 32475 is required.

5.2 REMOVAL OF SUB-ASSEMBLIES

Removal procedures for each of the Printed Circuit Board assemblies are outlined below. However, almost all the components in the instrument, with the exception of those in the early stages of the Y amplifiers, are

accessible without recourse to board removal.

(a) Y Amplifier Sub-assembly.

1. Remove and identify the leads from pins 9,10, 11,12,13,16,17,21,23,25 and 29 on the above named assembly.
2. Remove and identify the leads from pins 5 and 41 on the time base board.
3. Remove the two screws holding the heat sink plate to the side bar of the instrument, and remove the screw from the rear of the assembly.
4. Remove the knobs from both Y1 and Y2 attenuator switches and shift controls.
5. Remove the fixing nuts from the attenuator controls.
6. The assembly can now be removed. With the assembly out of the instrument, the attenuator screens can be released by removal of the four fixing screws.

(b) * Timebase and X Amp Sub-assembly

1. Remove and identify leads from pins 21, 23 and 25 on Y amp board.
2. Remove and identify leads to pins 5,10,11,26, 33,41,43,44,45 and 46.
3. Remove two fixing screws at rear of assembly.
4. Remove the knobs from VARIABLE TIME, X SHIFT and TRIG LEVEL controls, from TIME/CM and TRIG SELECT switches.
5. Remove fixing nuts from TIME/CM and TRIG SELECT switches.
6. The assembly can now be removed.

(c) CRT Replacement

1. Remove the tube base connector.
2. Remove the P.D.A. cap.
3. Remove lead from pin 21 on power supply board.
4. Remove screw holding tube shield to the tube support clamp and the two screws from tube support clamp. Slacken the c.r.t. face mounting.
5. Slide the tube and tube shield back to clear the front panel mountings and remove the tube and shield from the instrument. The tube can then be withdrawn from the shield.
6. Replace the tube in the reverse order.

When the tube is replaced it may require rotation to align the trace with the graticule (see section 5.4d)

5.3 FAULT FINDING

Before any fault location is attempted, it is suggested that all supply line voltages are checked with respect to 0V. These are given in Table 2.

Table 2.

LINE	MEASURED VOLTAGE
+20V	+19 to +21V
-20V	-19 to -21V
+170V	+160 to +180V
PDA	> +1,900V use meter at least
•-1.2kV	-1,140 to -1,240V 20,000 Ω/V

•Measured at junction R322, R324

* See OS250TV Supplement.

NOTE: The power supply input voltage should be approximately at the centre of the range for which the transformer taps are connected.

Table 3, indicating voltages at various circuit locations, may be used as a general guide and servicing aid. The front panel controls should be set as follows.

- BRILL, X SHIFT, Y2 SHIFT—all at mid position.
- Y1 SHIFT—to Y1 OFF position
- Y1 and Y2 INPUT switches—to ground position.
- TRIG SELECT—to Y1 +ve.
- ACF, AC, TVF—to A.C.
- LEVEL—to mid position, BRIGHT LINE on.
- TIME/CM—to X-Y

Adjust X and Y2 shift controls to bring spot to centre of tube.

If a fault on a printed circuit board cannot be cleared it is recommended that the instrument is returned to the manufacturer for repair (See section 7). When faults have been cleared it is recommended that the setting up procedure is followed. Calibration adjustments should be made only after a 15 minute warm up period following switch on.

Table 3

LOCATION	TYPICAL VOLTAGE
Y Amplifier Sub-assembly	
Base TR203, TR222	0V.
Collector TR204, TR214, TR217	+7V
Pin 22	+3.6V
Pin 21	+3V
Collector TR207	+9.3V
Pins 9 and 10	+110V
Emitter TR221	12V
X Amplifier and Timebase Sub-assembly	
Collector TR107	+4V
Collector TR102	+13V
Collector TR106	-20V
Collector TR109	+0.1V
Emitter TR113	+5.5V
Emitter TR115, TR116	-6.8V
Pins 34, 37.	+92V
Power Supply Sub-assembly	
Emitter TR302	+0.5V
Collector TR308	+3.5V

5.4 SETTING UP PROCEDURE

(a) Test Equipment

1. Multirange Test Meter. 0–2.5kV with sensitivity >20kΩ/V
2. Variable Autotransformer output voltage 95-260V at 1A.
3. Sine/Square wave signal generator covering the range 10Hz-100kHz amplitude 20mV – 5V. Such as ADVANCE H1E or J3.
4. Source of voltage and time calibration signals such as a Bradley Oscilloscope calibrator
5. A T.V. video waveform Generator, such as Advance type SG73.

6. Square-wave Generator. 500kHz flat top square wave Generator with adjustable amplitude 0.2V to 1V into 50Ω, having a risetime of less than 5ns such as Advance SG21A.
7. R.f. Sinewave Generator. 500kHz to >10MHz with 50kHz reference frequency. Output amplitude 25mV to 5V pk to pk into 50ohms, 10V unterminated. Amplitude accuracy at 50kHz and 500kHz to 10MHz within 3%.
8. 50 ohms B.N.C. termination, such as Advance TP19.

Power Supply Voltages

- (b) With the transformer connected for 222 to 260V operation, connect the instrument to the A.C. supply via a variable autotransformer, and set the voltage to 240V ± 1%. If the supply transformer is not connected for 222 to 260V operation, the test should be carried out with the supply within 1% of the nominal voltage shown in fig. 2.

Check the voltages to chassis on the following pins on the power supply board :—

+20V	+19.0V min	+21.0V max
-20V	-19.0V min	-21.0V max
+170V	+160V min	+180V max
PDA	>+1900V	

Adjust R320 (EHT) to give 155V across C315. Unless the instrument is supplied from a known stable source, the supply voltage should be checked at the same time that the potential across C315 is measured. Measure the voltage from the junction of R322, R324 to chassis which should be between -1140 to -1240V. This voltage should not change by more than ± 9V when the supply voltage is varied from 222V to 260V.

(c) Astigmatism

Set the front panel controls as follows:—
TIME/CM switch to X-Y, BRILLIANCE to mid position, X shift to mid position, Y1 and Y2 shifts to mid position and Y1 and Y2 VOLTS/CM switch to .2. Adjust X and Y2 shift to centre a spot on the screen. Adjust R332 (Astig) together with the BRILL and FOCUS controls to obtain a sharp round spot.

(d) Trace Rotation

Set the TIME/CM to 1ms/cm and bright line auto on. Rotate the c.r.t. to bring the trace exactly parallel with the horizontal graticule line. It may be necessary to slacken the c.r.t. face support screws to rotate the c.r.t.

(e) Geometry

Set the Y2 shift to off position, Y1 input switch to AC, Trigger Selector to Y1 and apply to Y1 input socket a 1kHz sinewave set to give approximately 8cm of Y deflection. Set the TIME/CM switch and level control so that approximately 10 cycles are displayed. Adjust R333 (Geom)

for a compromise between horizontal and vertical pin-cushioning and barrelling effects. Reset the FOCUS, and if necessary readjust R332 (Astig).

(f) **DC Balance**

Set the Y1 and Y2 input switches to ground. Adjust the Y1 and Y2 Bal controls to eliminate X and Y trace movement when Y1 and Y2 VOLTS/CM are switched from .2V/cm to 5mV/cm.

(g) **Timebase Calibration**

Switch TIME/CM to 1ms/cm, variable time in CAL position. Apply 1ms markers to the Y1 input, adjusting Y sensitivity to give approximately 2 cm amplitude and triggering without bright line auto. Adjust R169 (X1 Gain) for 1 pulse/cm. Set X10 switch on, change markers to .1ms/cm and adjust R162 (X10 Gain) for 1 pulse/cm. Switch X10 off and set TIME/CM to 10 μ s/cm. Change markers to 10 μ s and adjust C10 for 1 pulse/cm. Check the timebase accuracy on all ranges to specification. Check that the variable time control reduces the speed by greater than 2.5:1. Ensure that the trace length is greater than 10cm on all ranges. With 10X mag. on apply time markers and check that the speed accuracy is within specification on all ranges ignoring the non-linearity on the first 5cm. of the 0.1 μ s/cm. range. Switch off the X10 mag.

(h) **Y AMP Calibration**

Set both Y1 and Y2 attenuators to .2V/cm, both input switches to DC, and the TIME/CM to 5ms/cm. Apply 1V from a calibrator to Y1 and adjust R222 (Y Gain) for a 5cm display. Apply the same signal to Y2 input, trigger on Y2 and observe the deflection. Readjust R222 to equalise the errors from 5cm deflection between Y1 and Y2.

(i) **Input Capacity and Attenuator Compensation**
Capacitors C25 and C27 are selected such that the input capacitance is approximately 28pF.

To set the attenuator compensation, set the Y1 VOLTS/CM switch to 0.5, the input coupling to D.C. and the TIME/CM to 0.5ms. Connect a low impedance 3V, 1kHz square wave signal to the input and adjust C202 for a square top to the display.

Repeat for Y2, adjusting C222.

To equalise the input capacitance on all ranges, set the Y1 VOLTS/CM switch to 0.2, the input coupling to DC and the TIME/CM to 0.5ms. Connect a 1kHz square wave signal either via a 10:1 probe or a 1M Ω series resistor connected in parallel with a 10 to 40pF trimmer capacitor, mounted close to the input socket. Set the

input amplitude for approximately 6cm of display and adjust the probe compensation or the trimmer for a square top to the display. Set the Y1 VOLTS/CM switch to 0.5 and adjust C201 to regain the flat top to the display.

Repeat for Y2 adjusting C221.

(j) **Internal Calibrator**

Set Y1 attenuator to .2V/cm then apply to Y1 input a 1V \pm 1% squarewave calibrator and note the exact deflection. Remove the 1v squarewave and apply the internal calibrator to Y1 input. Adjust R304 (Cal) to give the deflection previously noted.

(k) * **Trigger Sensitivity**

Apply the CAL signal to the Y1 input, set to 5V/cm with the trigger set to Y1 and AC with BRIGHT LINE off. Rotation of the LEVEL control should give a stable display of the correct slope in both + and - positions. Check that timebase does not free run at any setting of the LEVEL control. Push the LEVEL control in. Rotation of the LEVEL control should show range with a stable display of the correct slope in both + and - positions but free running outside this range. Remove the calibrator from the Y1 input and set this input to GROUND. Check that the timebase free runs at all settings of the LEVEL control in both + and - positions.

Repeat for the Y2 channel.

(l) **ACF AND TV Trigger**

Set Y2 attenuator to 1V/cm and select ACF. Two stable trigger points of opposite slope should be found in the level control. Switch to TV, Y2+ and apply to Y2 input a video waveform from a video waveform generator. Adjust Y2 attenuator to give 1 to 2cm display. Adjustment of the trig level control should give a stable display triggered from a video frame pulse. Remove the video input and return trig switch to A.C.

(m) **EXT Trig**

With internal CAL signal applied to the Y2 input, the Y2 attenuator set to 5V/cm, and trig selector set to EXT, apply the CAL waveform also to the EXT trig socket via a 220k Ω resistor. Check that the instrument triggers correctly with the BRIGHT LINE both on and off.

(n) **Pulse Response**

Switch the Y1 attenuator to 5mV/cm and set TIME/CM to 1 μ s/cm. Apply a 500 kHz fast risetime square wave signal to Y1 input using a 50 Ω termination at the input socket to prevent cable reflections. Adjust output from generator to give 6cm display. Adjust C211 to extend the

* See OS250 TV Supplement.

flat top towards the leading edge. Adjust C209 for a square corner. Apply the signal generator Y2 to check the squareness of corner, then readjust C211 and C209 as necessary for a compromise square corner between Y1 and Y2 amplifiers. Check that the pulse response is square on all ranges between 5mV/cm and .2V/cm, adjusting the generator for 5cm on each range, on both Y1 and Y2 allowing a maximum of 4% overshoot or undershoot.

(o) **Bandwidth**

Set Y1 attenuator to 5mV/cm and apply the output of a constant amplitude generator to the Y1 input. Set frequency to 50kHz and adjust generator output to give 6cm display. Increase the frequency until amplitude falls to 4.2cm. This frequency should be greater than 10MHz. Repeat for Y2 channel.

(p) **HF Trigger**

Switch off the BRIGHT LINE.

With the constant amplitude generator applied to the Y2 input and the TIME/CM set to

1 μ s/cm, X10, set the generator frequency to 10MHz and adjust the output to give 1cm display. It should be possible to obtain a clearly triggered waveform by adjustment of the level control. Repeat for the Y1 channel.

(q) **X-Y Operation**

Switch the TIME/CM to X-Y and both Y1 and Y2 attenuators to 200mV/cm. Apply a 4V signal to the Y1 input socket. The X deflection should be 8cm \pm 5%. Apply 50kHz from the Constant Amplitude Generator to the Y1 input and ground the Y2 input. Adjust the generator to give a 10cm horizontal line.

Increase frequency until the line reduces to 7cm. This frequency should be greater than 500kHz.

(r) **Z Mod**

Set the Y1 attenuator to 1V/cm and apply both to the Y1 input and to the Z mod socket a 10V 1kHz square wave. Check that blanking is operating at normal brilliance levels.

ABBREVIATIONS USED FOR COMPONENT DESCRIPTIONS

RESISTORS

CC	Carbon Composition	$\frac{1}{2}$ W	10%	unless otherwise stated
CF	Carbon Film	$\frac{1}{8}$ W	5%	unless otherwise stated
MO	Metal Oxide	$\frac{1}{2}$ W	2%	unless otherwise stated
MF	Metal Film	$\frac{1}{4}$ W	1%	unless otherwise stated
WW	Wire Wound	6W	5%	unless otherwise stated
CP	Control Potentiometer		20%	unless otherwise stated
PCP	Preset Potentiometer Type MPD, PC		20%	unless otherwise stated

CAPACITORS

CE(1)	Ceramic		+ 80%	
			- 25%	
CE(2)	Ceramic	500V	\pm 10%	unless otherwise stated
SM	Silver Mica			
PF	Plastic Film		\pm 10%	unless otherwise stated
PS	Polystyrene			
PE	Polyester		\pm 10%	unless otherwise stated
PC	Polycarbonate			
E	Electrolytic (aluminium)		+ 50%	
			- 10%	
T	Tantalum		+ 50%	
			- 10%	

Component List and Illustrations

Section 6

Y AMPLIFIER

Ref	Value	Description	Tol %±	Part No.	Ref	Value	Description	Tol %±	Part No.
RESISTORS									
R201	10kl	MF	1	26338	R253	18k	CF		21811
R202	22k	CP		A4/32894	R254	470	CF		21797
R203	18k	CF		21811	R255	470	CF		21797
R204	470	CF		21797	R256	39k	CF		28728
R205	470	CF		21797	R257	470	CF		21797
R206	39k	CF		28728	R258	470	CF		21797
R207	470	CF		21797	R259	6k8	CF		21807
R208	470	CF		21797	R260	2k2	CF		21802
R209	6k8	CF		21807	R261	2k	MO		26731
R210	2k2	CF		21802	R262	18	CF		28709
R211	2k	MO		26731	R263	6k8	MO		28796
R212	18	CF		28709	R264	220	CF		21796
R213	6k8	MO		28796	R265	3k3	CF		21803
R214	220	CF		21796	R266	3k3	CF		21803
R215	3k3	CF		21803	R267	180	MO		26744
R216	3k3	CF		21803	R268	180k	CF		21822
R217	180	MO		26744	R269	12k	CF		21810
R218	180k	CF		21822	R270	10	CF		21793
R219	12k	CF		21810	R271	6k8	MO		28796
R220	10	CF		21793	R272	47	CF		28714
R221	47	CF		28714	R273	2k	MO		26731
R222	100	PCP		28520	R274	2k2	CF		21802
R223	330	CF		28721	R275	10	CF		21793
R224	12k	CF		21810	R276	22k	CF		21812
R225	56	CF		28715	R277	1k8	CF		28725
R226	3k3	CF	5	½W 18556	R278	2k7	CF		28726
R227	1k2	CF		21800	R279	1k8	CF		28725
R228	680	CF		28723	R280	15k	CF		28727
R229	10	CF		21793	R281	22k	CF		21812
R230	3k	MO	5	6W 33212	R282	22k	CF		21812
R231	47	CF		28714	R283	15k	CF		28727
R232	47	CF		28714	R284	22k	CF		21812
R233	22k	CF		21812	R285	1k	CF		21799
R234	120	CF		28718	R286	3.9k	CF		21804
R235	820	MO	5	4W 33212	R287	27k	CF		21813
R236	15k	CF		28727	R288	1k8	CF		28725
R237	180	CF		21795	R289	4k7	CF		21805
R238	47	CF		28714	R290	6k8	CF		21807
R239	10	CF		21793	R291	10k	CF		21809
R240	3k	MO	5	6W 33212	R292	27k	CF		21813
R241	1k2	CF		21800	R293	33k	CF		21814
R242	2k7	CF		28726	CAPACITORS				
R243	10	CF		21793	C201	6pF	Trimmer		25750
R244	560	CF		21798	C202	6pF	Trimmer		25750
R245	2k2	CF		21802	C203				
R246	2k2	CF		21802	C204	.01µF	CE(2)	25	250V 22395
R247	2k2	CF		21802	C205	.01µF	CE(2)	25	250V 22395
R248	2k2	CF		21802	C206	39pF	CE(2)		22371
R249	47	CF		28714	C207	.01µF	CE(2)	25	250V 22395
R250	10	CF		21793	C208	39pF	CE(2)		22371
R251	10kl	MF	1	26338	C209	10/40pF	Trimmer		29483
R252	22k	CP		A4/32894	C210	1000pF	CE(2)		22387

Component List and Illustrations

Section 6

Y AMPLIFIER (Cont.)

Ref	Value	Description	Tol %±	Part No.	Ref	Value	Description	Tol %±	Part No.
C211	10/40pF	Trimmer		29483	TR207	2N3904			24146
C212	220pF	PS	10	125V 11587	TR208	2N2369			23307
C213	270pF	CE(2)		22380	TR209	2N2369			23307
C214	68pF	CE(2)		22374	TR210	BF380			32902
C215	.1μF	CE(1)		30V 19647	TR211	BF380			32902
C216					TR212 } TR213 }	AE23			A32957
C217	560pF	CE(2)		22384		Matched Pair.			
C218	68pF	CE(2)		22374	TR214	2N3904			24146
C219	.01μF	CE(2)	25	250V 22395	TR215	2N3640			31781
C220	47pF	CE(2)		22372	TR216	2N3640			31781
C221	6pF	Trimmer		25750	TR217	2N3904			24146
C222	6pF	Trimmer		25750	TR218	2N2369			23307
C224	.01μF	CE(2)	25	250V 22395	TR219	2N2369			23307
C225	.01μF	CE(2)	25	250V 22395	TR220	BC212			29327
C226	47pF	CE(2)		22372	TR221	BC212			29327
C227	.01μF	CE(2)	25	250V 22395	TR222	2N3906			21533
C228	27pF	CE(2)		22369					
C229	27pF	CE(2)		22369	DIODES				
C230	.01μF	CE(2)	25	250V 22395	D201	IN3595			29330
C231	15pF	CE(2)		22366	D202	IN3595			29330
C232	15pF	CE(2)		22366	D203	IN4148			23802
C233					D204	IN4148			23802
C234	.01μF	CE(2)	25	250V 22395	D205	IN4148			23802
C235	.01μF	CE(2)	25	250V 22395	D206	IN4148			23802
C236	47pF	CE(2)		22372	D207	IN4148			23802
C237	39pF	CE(2)		22371	D208	IN4148			23802
C238	100pF	CE(2)		22376	D209	IN4148			23802
C239	.01μF	CE(2)	25	250V 22395	D210	IN4148			23802
C240	.01μF	CE(2)	25	250V 22395	D211	IN4148			23802
C241	.1μF	CE(1)		30V 19647	D212	IN4148			23802
C242	.1μF	CE(1)		30V 19647	D213	IN4148			23802
C243	.1μF	CE(1)		30V 19647	D214	IN4148			23802
C244	330pf	CE(2)		22381	D215	IN3595			29330
C245	0.1μF	CE(1)		30V 19647	D216	IN3595			29330
C246	68pF	CE(2)		22374					
TRANSISTORS					MISCELLANEOUS				
TR201 } TR202 }	AE23	Matched Pair		A32957	L201	33μH			33204
TR203	2N3906			21533	L202	33μH			33204
TR204	2N3904			24146	L203	Bead Ferrite			4442
TR205	2N3640			31781		FX1115			
TR206	2N3640			31781	L204	Bead Ferrite			4442
						FX1115			

214	R215	R217	R216		R229		R224	R228	R230	R232	R235	R240	R241	R286	R290	R291	
219	R265	R218	R266	R221	R274	R275	R223	R227	R226	R231	R238	R235	R237	R242	R287	R290	R2M3
264	R244	R267	R272	R273	R271		R276	R225	R278	R249	R234	R222	R282	R280	R284	R285	
269	R270						R281	R222						R288	R289	R292	
	C206	C207					C249	C210	C237	C208	C236	C211		C214	C215		
	C226	C227					C228	C230	C230	C209	C212	C220		C217			
	C238						C234	C231	C232	C235	C246		C245	C218	C219	C244	
TR205	TR205			D203	D204	D205		TR207		L201	L203	L204	L202	TR220	TR221		
TR215	TR216			D206	D207	D207		TR218	D210	D212	D208	D209	D213	D214			

NOTES
 1. COMPONENTS CONTAINED WITHIN DOTTED LINES ARE NOT MOUNTED ON PRINTED CIRCUIT BOARD.

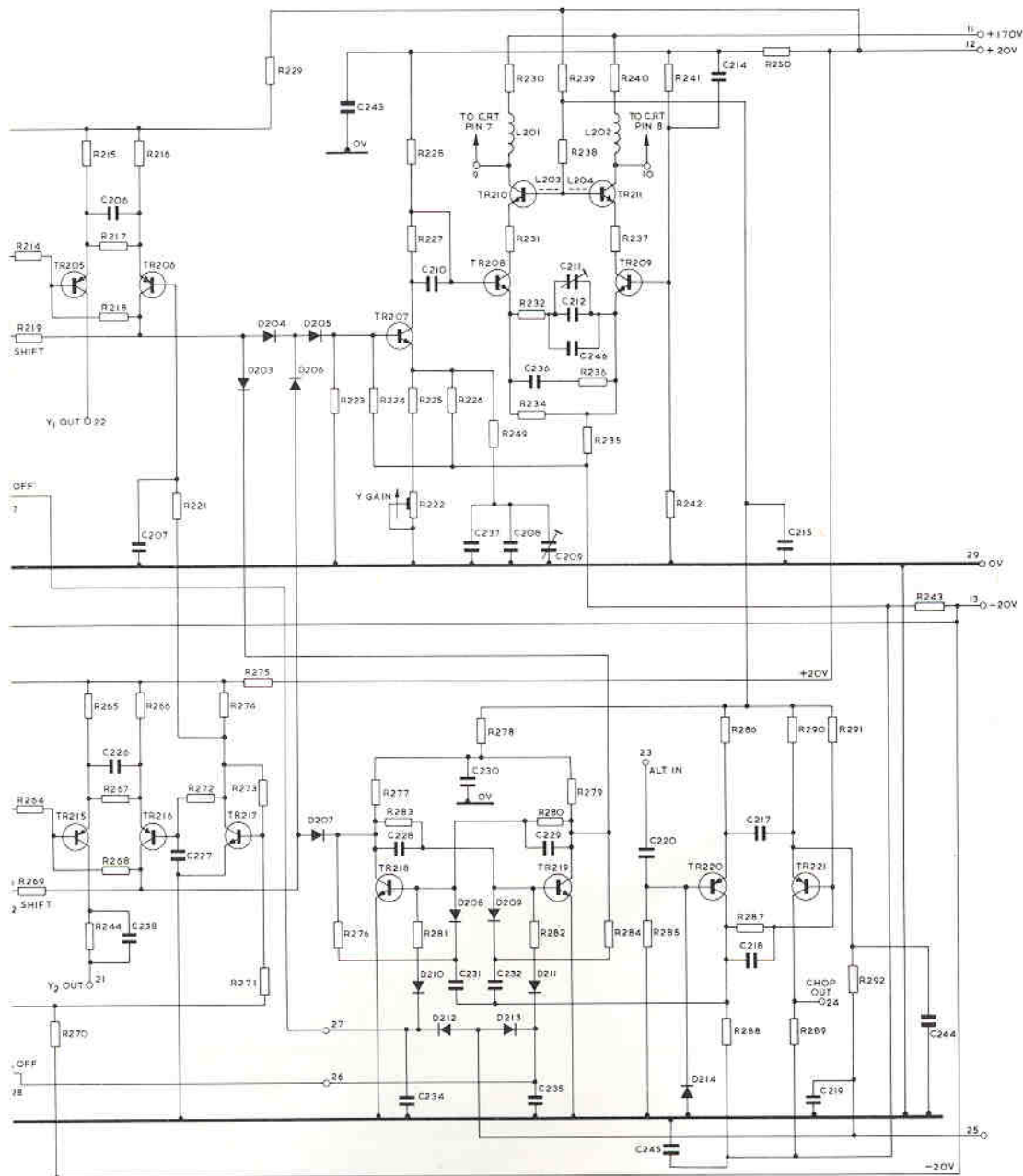

Fig. 3 Y Amplifier circuit

Component List and Illustrations

Section 6

TIMEBASE AND X AMPLIFIER

Ref	Value	Description	Tol %±	Part No.	Ref	Value	Description	Tol %±	Part No.
RESISTORS									
R101	22k	CF		21812	R155	18k	CF		21811
R102	22k	CF		21812	R156	100	CF		21794
R103	1k2	CF		21800	R157	56k	CF	5	1W 19058
R104	47	CF		28714	R158	220	CF		21796
R105	10	CF		21793	R159	2k2	CF		21802
R106	100k	CF	5	1W 19061	R160	10k	MO	5	4W 29481
R107	560	CF		21798	R161	100	CF		21794
R108	220	CF		21796	R162	100	PCP		28520
R109	220	CF		21796	R163	2k	MO		26731
R110	620	MO		22485	R164	1k8	CF		28725
R111	10	CF		21793	R165				
R112	390	CF		28722	R166	1k5	CF		21801
R113	1k2	CF		21800	R167	100	CF		21794
R114	3k3	CF	5	½W 18556	R168	10k	MO	5	4W 29481
R115	1k2	CF		21800	R169	1k	PCP		26870
R116	1k2	CF		21800	R170	2k	MO		26731
R117	10	CF		21793	R171	56k	CF	5	1W 19058
R118	47	CF		28714	R172	1k8	CF		28725
R119	100k	CF		21819	R173	100	CF		21794
R120	6k8	CF		21807	R174	1k8	CF		28725
R121	270	CF		28720	R175	1k8	CF		28725
R122	1k5	CF		21801	R176	10	CF		21793
R123	3k3	CF		21803	R177	10k	CF		21809
R124	1M	CF		31840	R178	27	CF		28711
R125	100	CF		21794	R179	270k	CF		32356
R126	4k7	CF		21805	R180				
R127	10k	CF		21809					
R128	2k2	CF		21802					
R129	120	CF		28718					
R130	1k	CF		21799					
R131	1k	CF		21799					
R132	2k7	CF		28726					
R133	1k	CF		21799					
R134	12k	CF		21810					
R135	18k	CF		21811					
R136	3k9	CF		21804					
R137	3k9	CF		21804					
R138	10k	CF		21809					
R139	47k	CF		21815					
R140	47k	CF		21815					
R141	100k	CF		21819					
R142	10k	CF		21809					
R143	1k	CF		21799					
R144	1k5	CF		21801					
R145	100k	CF		21819					
R146	15k	CF		28727					
R147	2M2	CC		1180					
R148	68k	CF		21816					
R149	2k7	CF		28726					
R150	100	CF		21794					
R151	1k2	CF		21800					
R152	56k	CF	5	1W 19058					
R153	27k	CF		21813					
R154	3k9	CF		21804					
CAPACITORS									
C101	100pF	CE(2)							22376
C102	.01µF	CE(2)	25	250V					22395
C103	10µF	E		25V					32180
C104	.01µF	CE(2)	25	250V					22395
C105	.01µF	CE(2)	25	250V					22395
C106	33pF	CE(2)							22370
C107	.47µF	CE(1)		3V					35352
C108	33pF	CE(2)							22370
C109	270pF	CE(2)							22380
C110	.1µF	CE(1)		30V					19647
C111	27pF	CE(2)							22369
C112	22µF	E		25V					32181
C113	.47µF	CE(1)		3V					35352
C114									
C117	27pF	CE(2)							22369
C118	27pF	CE(2)							22369
C119	4700pF	CE(2)	25	500V					22393
C120	.01µF	CE(2)	25	250V					22395
C121	100pF	CE(2)							22376
C122	27pF	CE(2)							22369
C123	22pF	CE(2)							22368
C128	180pF	PS	5	125V					33343
C129	10pF	CE(2)							22364

Component List and Illustrations

Section 6

TIMEBASE AND X AMPLIFIER (Cont.)

Ref	Value	Description	Tol %±	Part No.	Ref	Value	Description	Tol %±	Part No.
TRANSISTORS									
TR101		2N2369		23307	TR116		BF258		31490
TR102		2N2369		23307	TR117		BC212		29327
TR103		2N2369		23307					
TR104		2N2369		23307					
TR105		BC212		29327					
TR106		BC182B		33205	DIODES				
TR107		BC182B		33205	D101		IN3595		29330
TR108		2N2369		23307	D102		IN4148		23802
TR109		2N2369		23307	D103		IN4148		23802
TR110		2N2369		23307	D104	8V2	ZENER	5	3798
TR111		BC212		29327	D105		IN4148		23802
TR112		BC212		29327	D106		IN4148		23802
TR113		BC182B		33205	D107		IN4148		23802
TR114		BC212		29327	D108		IN4148		23802
TR115		BF258		31490	D109		IN4148		23802
					D110		IN4148		23802

RESIS	R106 R107	R103 R105 R176	R104 R110 R108 R109	R111 R112 R113 R178	R125 R114 R119 R120	R115 R118 R128 R129	R116 R129	R180 R117 R121 R123 R122 R126	R130	R127 R102 R10	R124 R101	R10-1B R131	R177 R133	R134 R138 R142 R143	R135 R142 R143	R136 R137 R139 R140 R141 R179	R146 R147	
CAP	C101	C103	C105	C109	C102	C112 C113	C119 C121	C106 C108	C104	C111 C107	C110	C14-16	C118 C117	C10-13 C120	C122	C129		
MISC	S130F SKC	TR101	TR102 TR107	TR103	TR104	S12 S130B	TR105	TR106	D101	S10	TR108	TR109	D106 S140B D102 S14bB D106 D107	D103	D107	D108	D109	D103

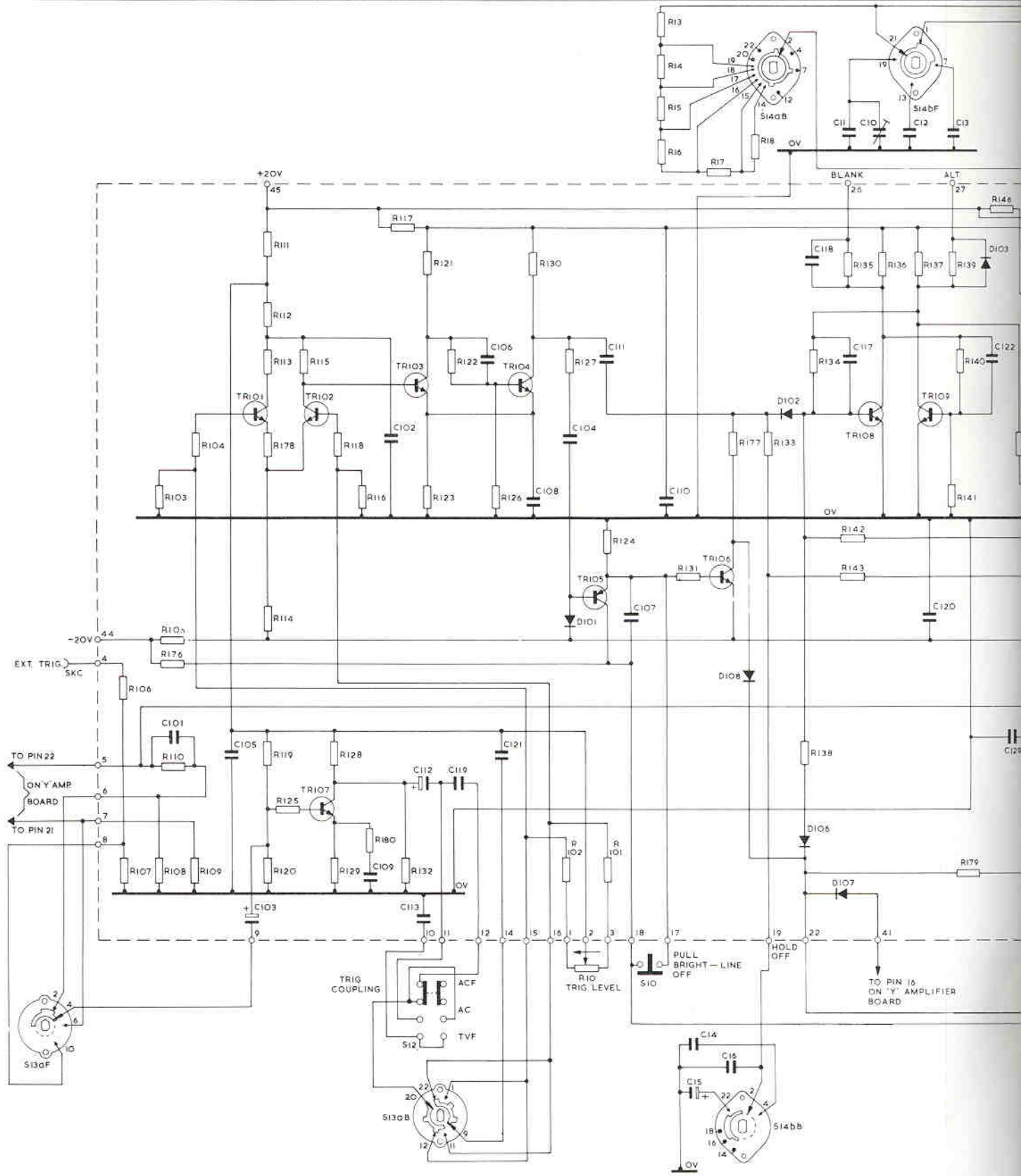

39	R146	R144	R147	R150	R11	R152	R154	R155	R157	R160	R161	R167	R168	R171	R172
40	R145	R148	R151	R153	R156	R174	R159	R163	R158	R162	R165	R154	R170	R175	R173
41	R179											R169			R12
	C122														
	C129														
	DIO3	TR110	DIO9	TR111	TR112	TR113	DIO4	DIO5	SKE	TR114	TR115	S11	TR116	TR117	
															Si40F

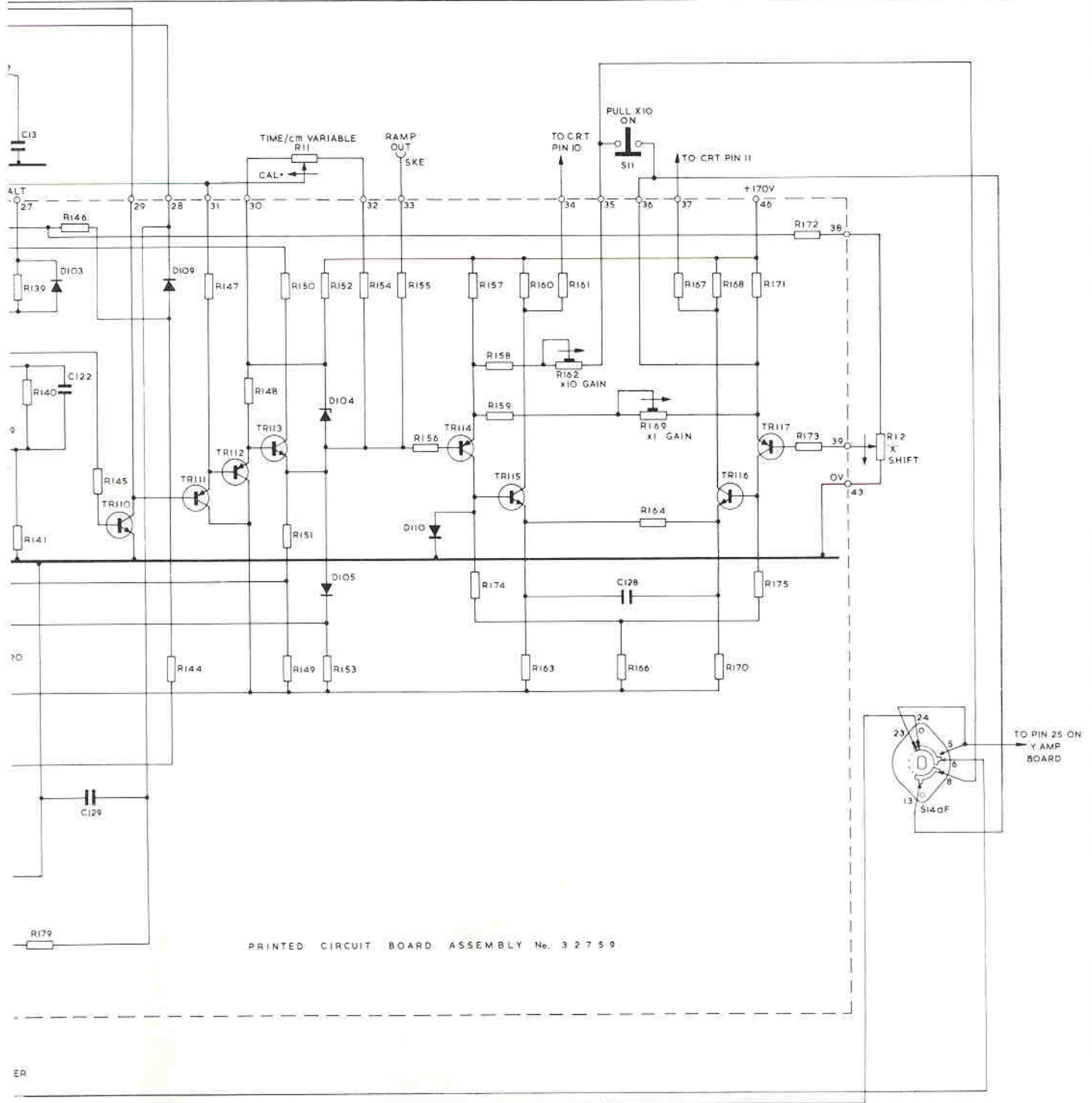

PRINTED CIRCUIT BOARD ASSEMBLY No. 3 2 7 5 9

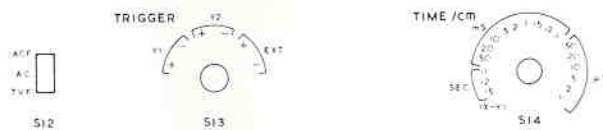

SWITCH MARKINGS AS VIEWED FROM FRONT PANEL

Fig. 4 Timebase and X amplifier circuit

Component List and Illustrations

Section 6

POWER SUPPLY

Ref	Value	Description	Tol %±	Part No.	Ref	Value	Description	Tol %±	Part No.
RESISTORS									
R301	5k6	CF		21806	C305	.01μF	CE(2)	25	1.5kV 23603
R302	1k	CF		21799	C306	5000pF	CE(1)		3kV 1514
R303	8k2	CF		21808	C307	5000pF	CE(1)		3kV 1514
R304	10k	PCP		28525	C308	5000pF	CE(1)		3kV 1514
R305	100k	CF		21819	C309	4μF	E		450V 23599
R306	47k	CF		21815	C310	4μF	E		450V 23599
R307	82	CF		28717	C311	4μF	E		450V 23599
R308	1k	CF		21799	C312	4μF	E		450V 23599
R309	5R6	CF	5	½W 33210	C313	.02μF	CE(1)		1.5kV 25223
R310	2k2	CF		21802	C314	470pF	CE(2)	20	1.5kV 33207
R311	1k3	CF		33338	C315	4μF	E		450V 23599
R312	15k	CF		28727	C316	4.7μF	E		63V 32195
R313									
R314	5R6	CF	5	½W 33210	C317	.01μF	CE(2)	25	250V 22395
R315	82	CF		28717	C318/9	.01μF	CE(2)	25	250V 22395
R316	2k2	CF		21802					
R317	1k3	CF		33338	TRANSISTORS				
R318	47k	CF		21815	TR301		MPS U10		32924
R319	43k	MO		28813	TR302		BC 182B		33205
R320	10k	PCP		28525	TR303		BC 182B		33205
R321	1M5	CC		7016	TR304		BC212		29327
R322	3M3	CF	5	2W 29482	TR305		BC212		29327
R323	2M2	CC		1180	TR306		BC182B		33205
R324	47k	CC		2933	TR307		2N 2369		23307
R325					TR308		2N 5831		33209
R326	100k	CF		21819	MR301		WO4		29367
R327	47k	CF		21815					
R328	4M7	CC		597	DIODES				
R329	270k	CF		32356	D301		MR995A		32903
R330					D302		MR995A		32903
R331	1M5	CC		7016	D303		MR995A		32903
R332	220k	PCP		29363	D304		IN 4007		52337
R333	470k	PCP		28529	D305		IN 4148		23802
R334	100k	CF		21815	D306		IN 4148		23802
R335	27k	CF	5	2W 33211	D307		IN 4148		23802
R336	15k	CF	5	½W 18564	D308		IN 4148		23802
R337	22k	CF	5	½W 18566	D309		IN 4148		23802
R338	4k7	CC		3427	D310		IN 4148		23802
R339	2M2	CC		1180	D311		IN 4148		23802
R340					D312		IN 4148		23802
R341	2M2	CC		1180	D313		IN 4148		23802
R342	2M2	CC		1180	D314		IN 4148		23802
					D315	6V8	ZENER	5	4666
					D316	6V8	ZENER	5	4666
					D317		IN 4148		23802
CAPACITORS									
C301	4μF	E		450V 23599					
C302	4μF	E		450V 23599					
C303	4μF	E		450V 23599					
C304	4μF	E		450V 23599					

RESISTORS	R306 R318	R307 R315	R309 R314	R310 R311 R317 R316	R304 R303	R305 R337	R301 R341 R342 R339	R302 R336	R335 R338
CAPACITORS				C317 C318	C305	C306	C307	C315 C308	C31
MISC.	D308 D309 D306 D305	TR305 D316 D315 TR304	TR306 D310 TR303 D307			TR307 D303	D311 D302	MR301	TR308 D313 TR301

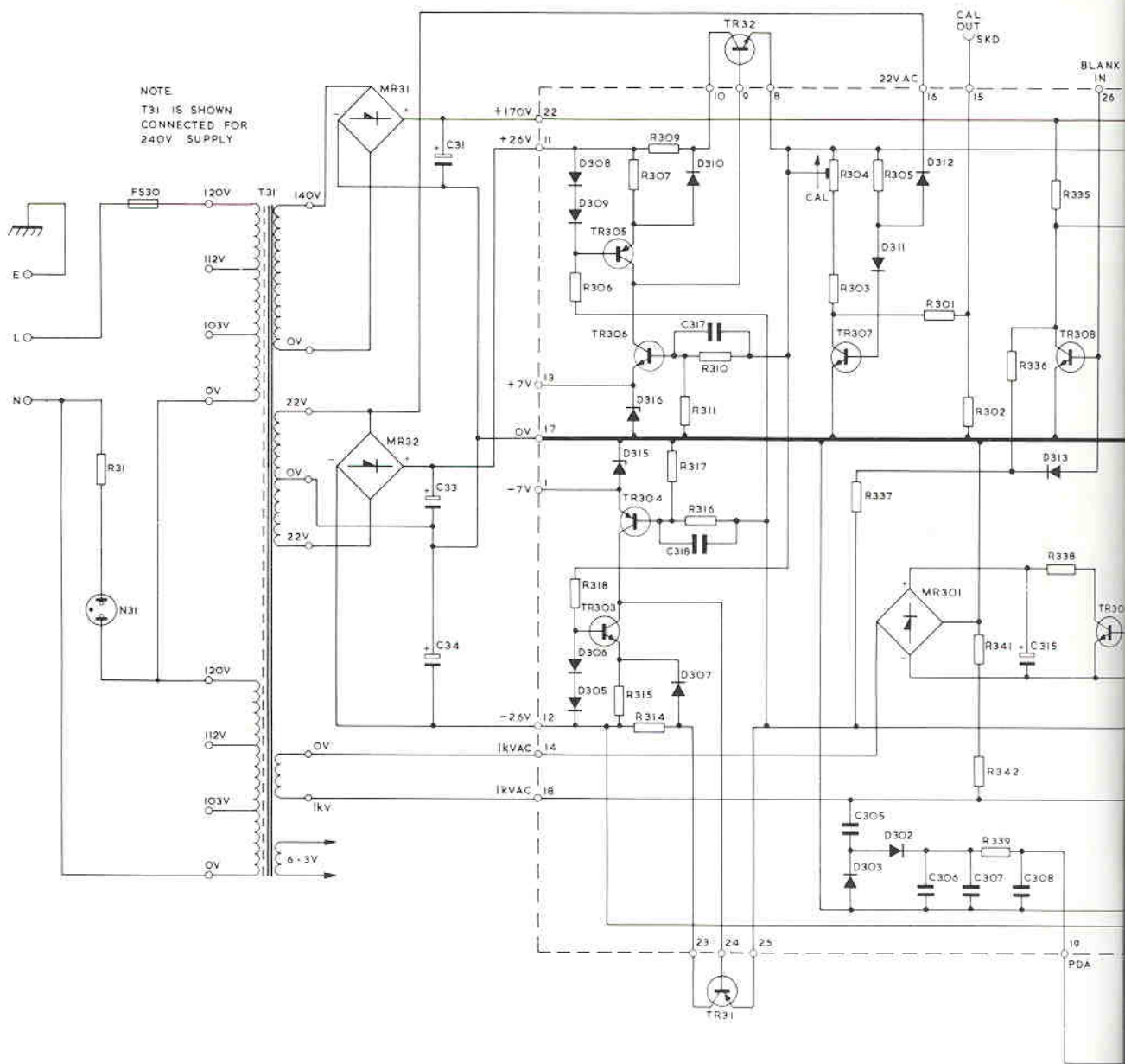

NOTE:

1. COMPONENTS NOT ENCLOSED WITHIN THE DOTTED AREA ARE CALLED FOR ON INTERCONNECTION DIAGRAM SK.2349.

35	R323	R332	R333	R320	R324	R331	R329
38		R312	R321	R319	R328	R326	R327
				R334			
	C316			C301-304		C309-312	
R308		TR302		C313		C314	
13	TR301	D304	D301		D314	D317	

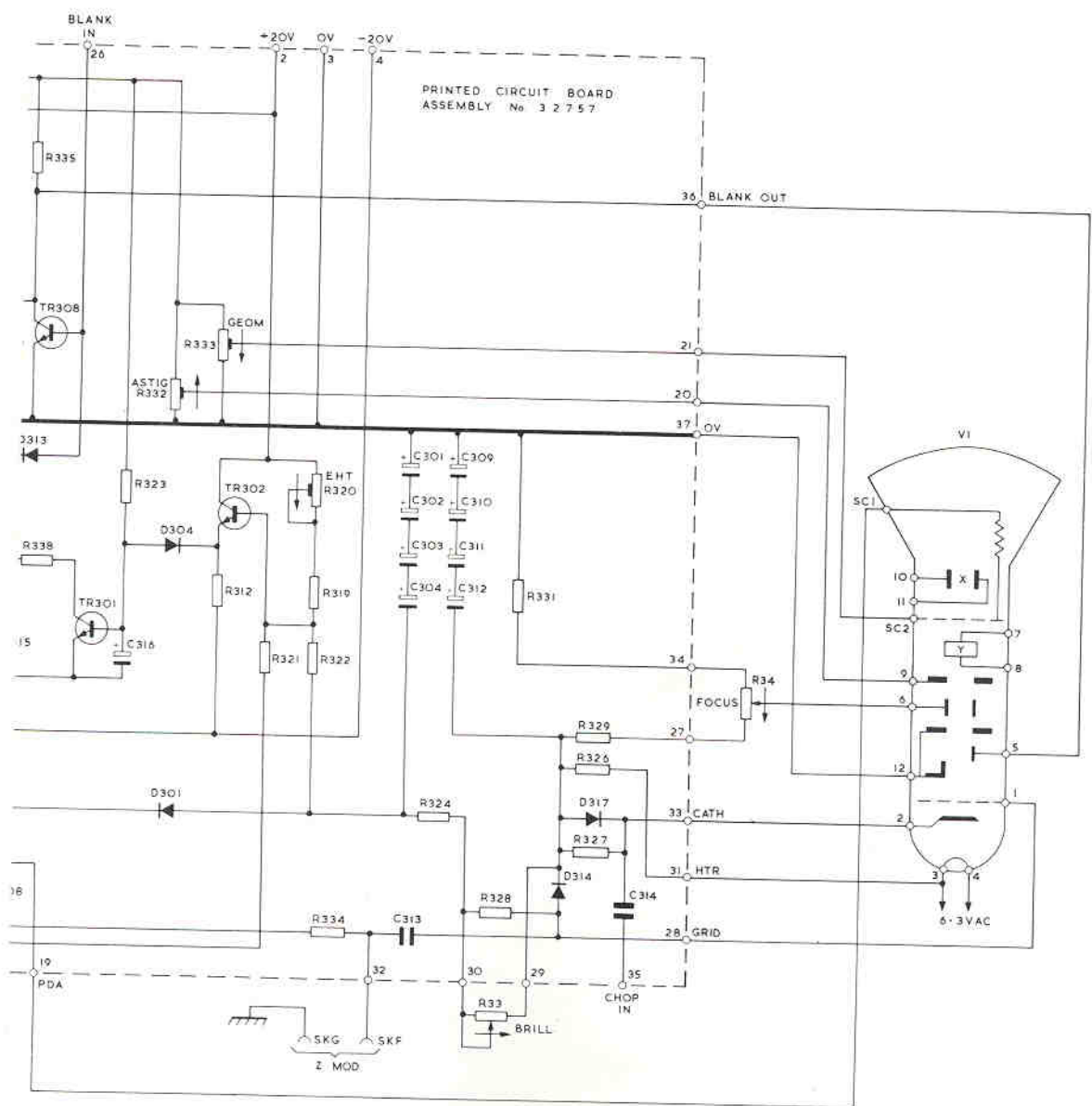

Fig. 5 Power supply circuit

Component List and Illustrations

Section 6

INTERCONNECTION

Ref	Value	Description	Tol %±	Part No.	Ref	Value	Description	Tol %±	Part No.
RESISTORS									
R10	100k	CP With S10		A4/32897	C26	470pF	PS	10	125V 11492
R11	10k	CP With S11		A4/32898	C27	8.2pF	CE(2)	1pF	500V 22363
R12	2k2	CP		A4/32896	C28	470pF	PS	10	125V 11492
R13	100k	MF	1	29476					
R14	100k	MF	1	29476	C31	100μF	E		275V 32906
R15	301k	MF	1	29477					
R16	499k	MF	1	26342	C33	1000μF	E		40V 32907
R17	1M	MF	1	26346	C34	1000μF	E		40V 32907
R18	3M01	MF	1	29478	C35	1000pF	CE(2)		22387
					C40	5.6kpF	CE(2)		22394
R20	990k	MF	1	26345	C41	5.6kpF	CE(2)		22394
R21	22	CF		28710	TRANSISTORS				
R22	22	CF		28710	TR31		BD166		32901
R23	990k	MF	1	26345	TR32		BD165		32900
R24	470k	CC		4906	MR31		WO4		29367
R25	1M	MF	1	26346	MR32		WO4		29367
R26	22	CF		28710	SOCKETS				
R27	22	CF		28710	SKA		50ΩBNC		1222
R28	470k	CC		4906	SKB		50ΩBNC		1222
R29	1M	MF	1	26346	SKD		4mm Black		30097
					SKE		4mm Black		30097
R31	68k	CF		21816	SKF		4mm Black		29492
					SKG		4mm Black		29492
R33	220k	CP With S30		A4/32899	SKH		4mm Black		29492
R34	1M	CP		A4/32893	SWITCHES				
					S10		Part of R10		
R40	16k	MF	1	29361	S11		Part of R11		
R41	15k8	MF	1	33291	S12				25869
R42	5k23	MF	1	33290	S13				32636
R43	1k72	MF	1	33289	S14				32634
R44	787	MF	1	33288	S20				25869
R45	360	MF	1	33287	S21				32635
R46	16k	MF	1	29361	S24				
R47	15k8	MF	1	33291	S25				25869
R48	5k23	MF	1	33290	S26				32635
R49	1k72	MF	1	33289	S27		Part of R52		
R50	787	MF	1	33288	S28		Part of R53		
R51	360	MF	1	33287	S30		Part of R33		
R52	22k	CP With S27		A4/32895	S31				25869
R53	22k	CP With S28		A4/32895	MISCELLANEOUS				
R54	22	CF		28710	V1		CRT D13-610 GH		32904
R55	22	CF		28710			OR		
R56/57	330k	CC		4408			CRT D13-610 GM		32905
							Long Persistence		
CAPACITORS									
C10	6/25pF	Trimmer		23593	FS30		FUSE 220V Supply 250mA		33684
C11	68pF	SM	5	4513			OR		
C12	.01μF	PS	1	24886			FUSE 110V Supply 500mA		33685
C13	1μF	PC	2	33206	T31		Transformer		A1/32637
C14	.047μF	CE(1)		30V 2793	N31		Indicator Neon Type Q		26586
C15	4.7μF	E		63V 32195	L10		Ferrite Bead FX1242		26986
C16	1000pF	CE(2)		22387	L11		Ferrite Bead FX1242		26986
C21	.1μF	PE		400V 29495					
C22	.01μF	CE(1)		500V 24902					
C23	.1μF	PE		400V 29495					
C24	0.1μF	CE(1)		500V 24902					
C25	8.2pF	CE(2)	1pF	500V 22363					

	R57 R13	R25 R52	R27 R24	R50 R22	R25 R55	R20 R29	R54 R23	R28	R43 R44 R45	R42 R41 R40	R47 R48	R46	
RESIS	R14 R15 R16 R17 R18 R19 R20 R21 R22	R23 R24 R25 R26 R27 R28 R29 R30 R31	R32 R33 R34 R35 R36 R37 R38 R39 R40	R41 R42 R43 R44 R45 R46 R47 R48 R49	R50 R51 R52 R53 R54 R55 R56 R57 R58	R59 R60 R61 R62 R63 R64 R65 R66 R67	R68 R69 R70 R71 R72 R73 R74 R75 R76	R77 R78 R79 R80 R81 R82 R83 R84 R85	R86 R87 R88 R89 R90 R91 R92 R93 R94	R95 R96 R97 R98 R99 R100 R101 R102 R103	R104 R105 R106 R107 R108 R109 R110 R111 R112	R113 R114 R115 R116 R117 R118 R119 R120 R121	R122 R123 R124 R125 R126 R127 R128 R129 R130
CAP	C41	C21 C23 C11	C24 C26 C12	C40 C28 C13	C14 C15	C28 C25 C16	C22						
MISC	SKA SKB	SKC SKE	S10 S11 S12	S27 S28 S14aB	S20 S25	S21aF S21aB S26aF S14bF	S21aB S14bB S13aB	S13aF	S21aB S14aF	S21bF	S25bF	S25bB	

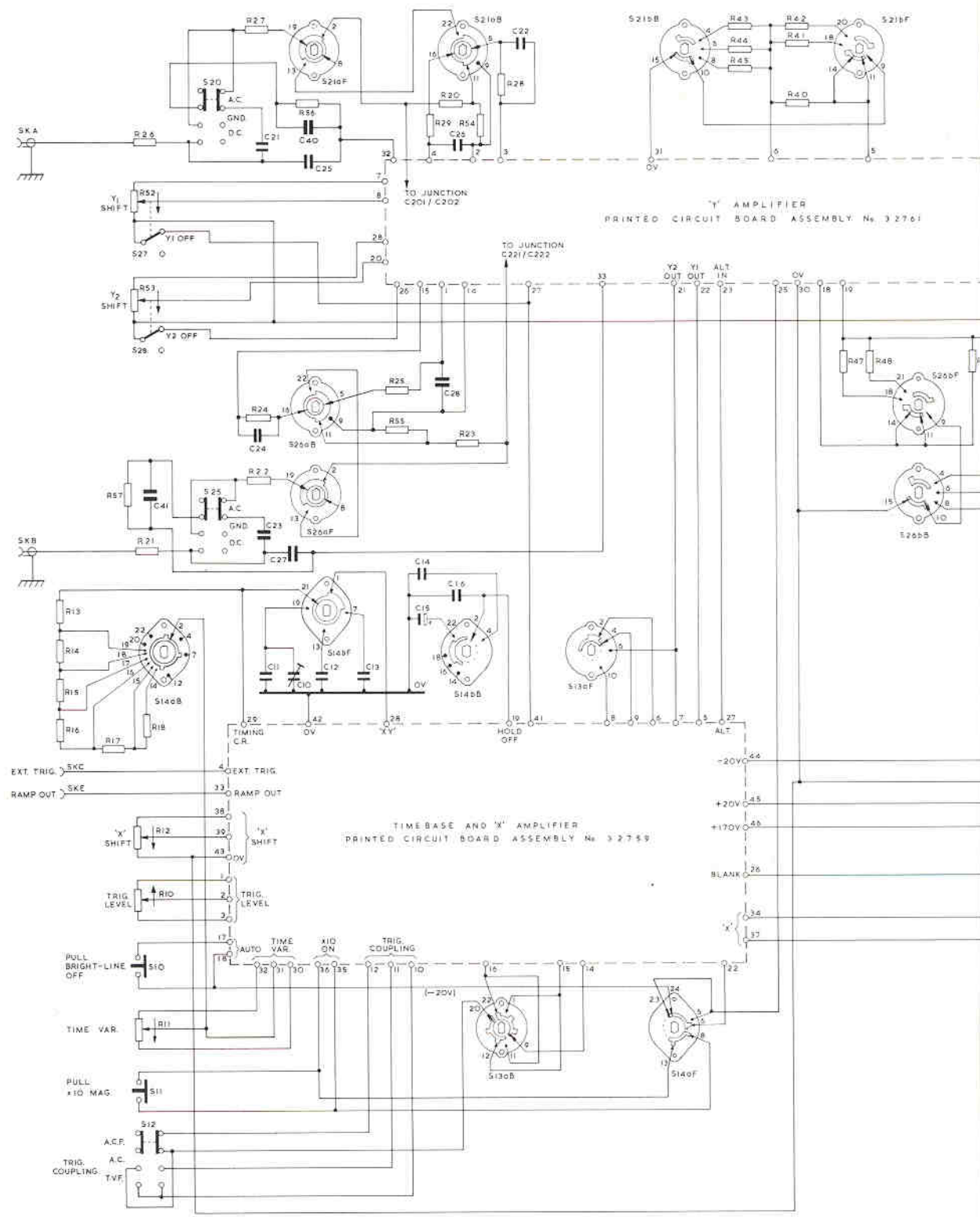

NOTE

R424	1k	CF	OS250 TV only	21799
R425	56k	CF	OS250 TV only	28729
S13			OS250 TV only	33995

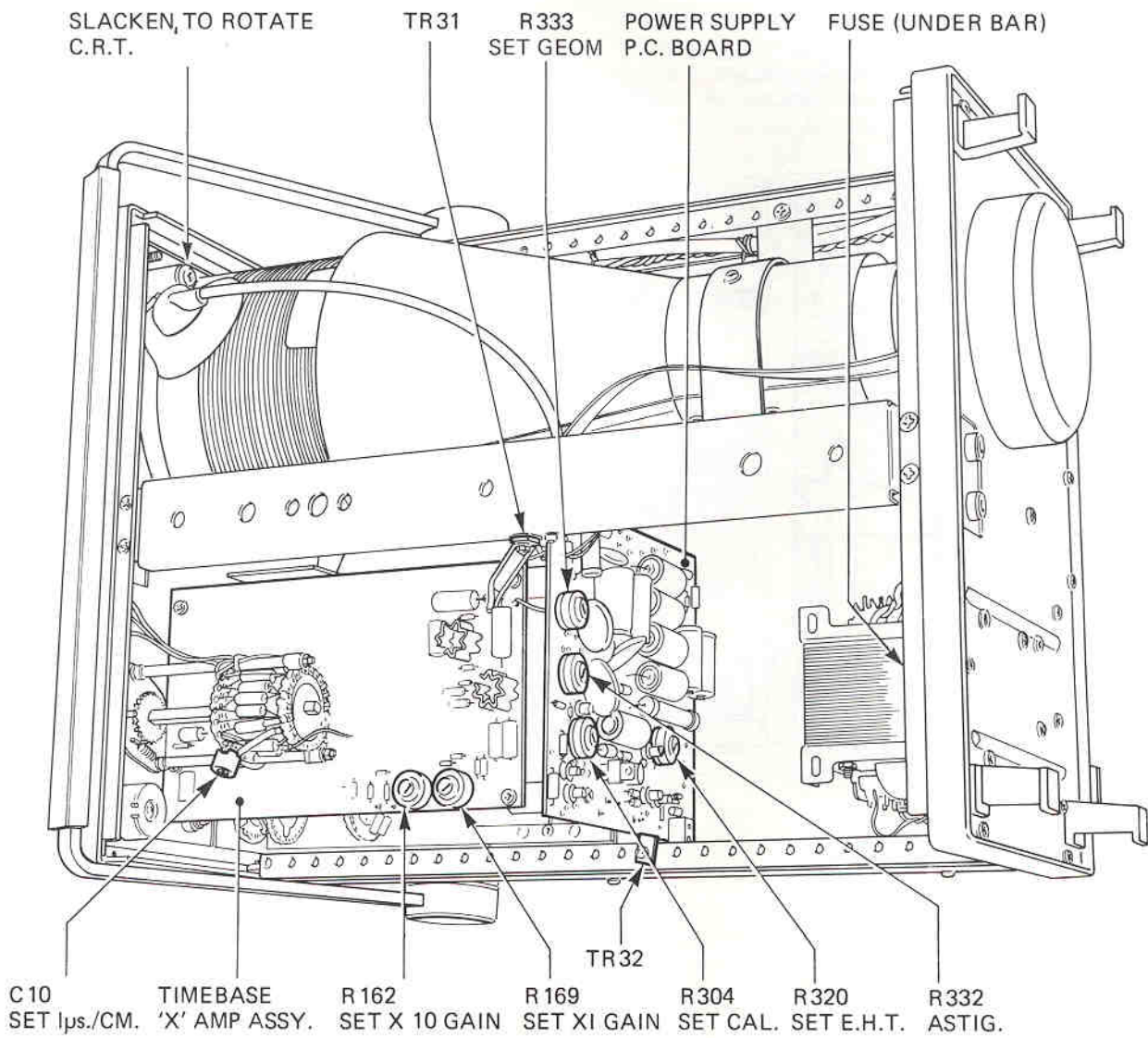

Fig. 7 Top view

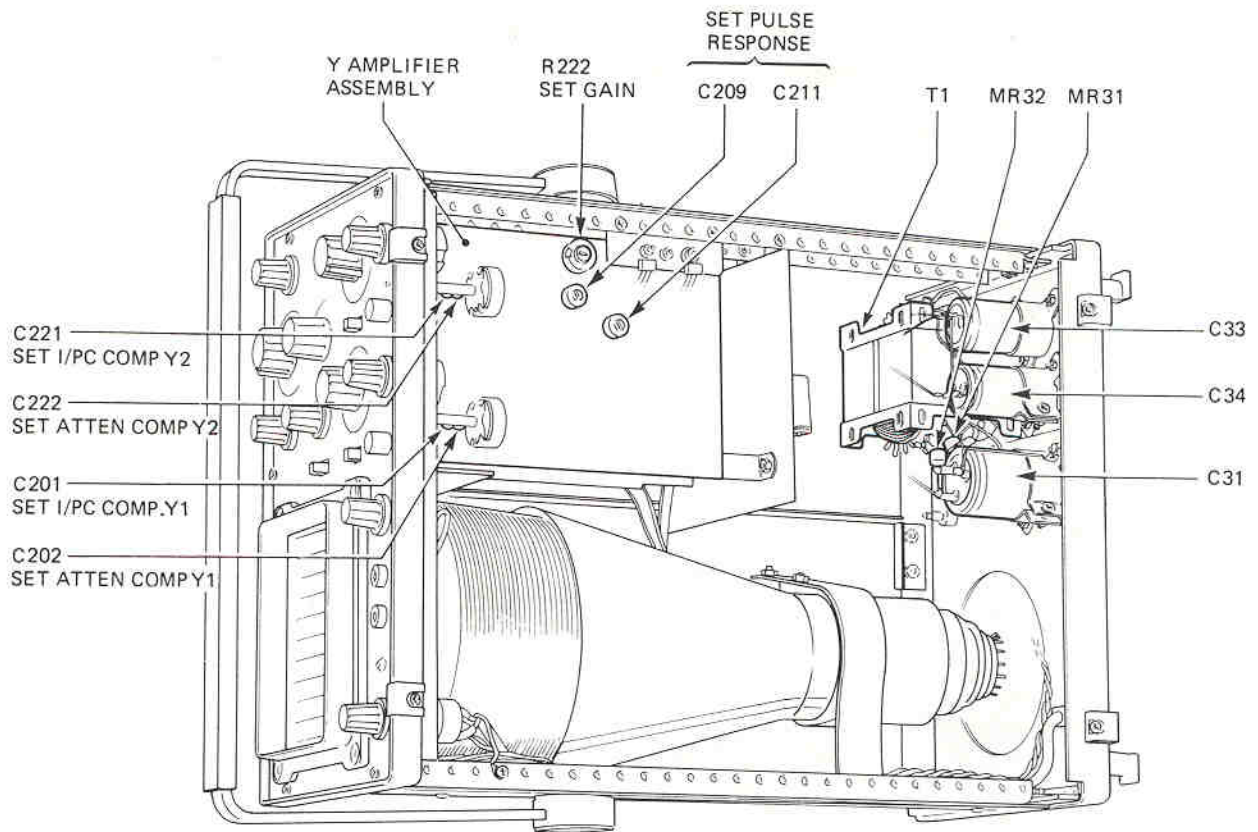

Fig. 8 Bottom view

AMENDMENT SHEET FOR OS250 INSTRUCTION MANUAL

Please note that with effect from Serial No.4901 it is likely that the supply range selection is by switch rather than wire links on the transformer. The following amendments apply to the Handbooks:-

Section 2 Specification

Supply	103 - 127V 45 - 400 Hz
	198 - 242V "
	216 - 264V "
	approx. 25VA

Section 3 Operation

3. 1. 2

Check that the supply range switch is set to suit the supply. This switch can be seen and adjusted through the cut-out in the back panel. NOTE: This switch must not be operated while the instrument is switched on. The internal fuse has to be changed when changing between the 103 - 127V range and the 198 - 264V ranges. (See section 5.1 as modified below).

Section 4 Circuit Description

4.9 Power Supplies

All power supplies are derived from transformer T1. The primary winding is in series or parallel and the taps selected to cover the three supply voltage ranges by S31.

Section 5 Maintenance

5.1 (b) Transformer Tap connections.

DELETE

(c) Fuse Replacement

- - - mounted on the rear panel beside the transformer.

For 198 to 264V operation a 250mA slow blow fuse. Advance Part No. 33684 is required. For 103 - 127V operation a 500mA slow blow fuse. Advance Part No. 33685 is required.

5.4 (b) Power Supply Voltages.

The tests in this action should be carried out at $115V \pm 1\%$, $220V \pm 1\%$ or $240V \pm 1\%$ depending on the setting of the supply range switch S31 R320 (FHT) should be adjusted to give 185V across C 315.

Page 24 Component List

Amend T31 Part No. to read 34799

KVALITET OG ØKONOMI OS250 10MHz/5mV

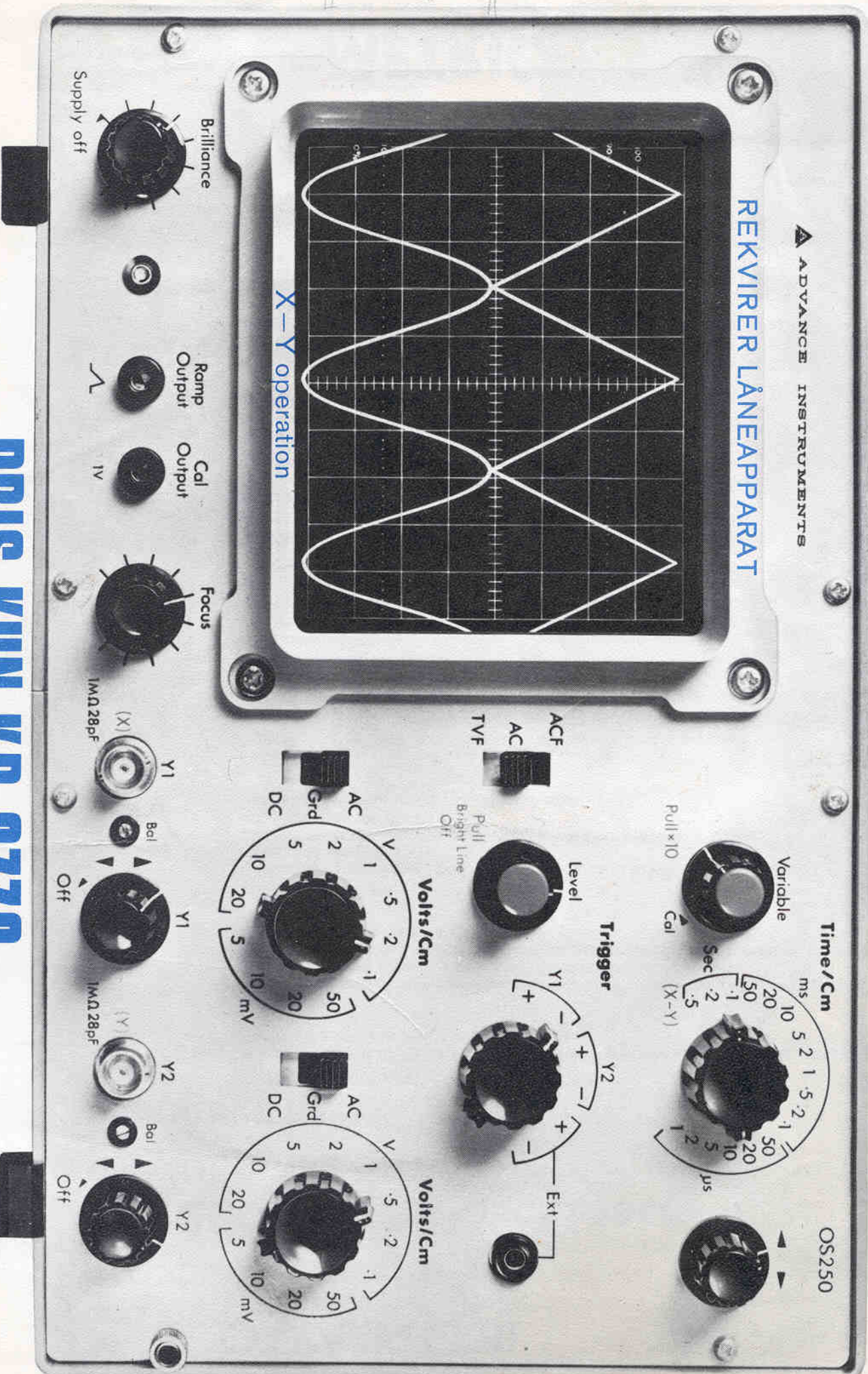

REKVIRER LÅNEAPPARAT

ADVANCE INSTRUMENTS

X-Y operation

Februar 1974

PRIS KUN KR. 2770,-

EKSL. MOMS

NATURLIG STØRRELESE

Z mod



ADVANCE

OS250 2-KANALS OSCILLOSKOP DC-10MHz, 5mV/cm, ægte X-Y

TEKNISKE DATA

KATODESTRÅLERØR

5" fladt rør giver 10×8 cm areal med 3,6 kV accelerationsspænding. P31 fosfor (standard) eller P7 (lang efterglød) mod mindre merbetaling.

DISPLAY MODES:

Enkanal: Y₁ og Y₂.

To-kanal: Alternierende sweep eller chopped (250 kHz), automatisk indstillet ved tidsbasis-omskifter. Chopped sweep til 1 ms/cm, alternerende 0,5 ms/cm–1 μs/cm.

OS250 kan X-Y kobles (DC – 500 kHz) med fuld følsomhed (5 mV) og attenuatorkontrol i begge akser. Fasefejl maks. 3°.

Y-FORSTÆRKERE

To identiske kanaler – Y₁ og Y₂. Følsomhed – 5 mV/cm til 20 V/cm i 1–2–5 sekvenser.

Nøjagtighed: Bedre end 5 %.

Båndbredde: DC–10 MHz, indgangsimpedans: 1 Mohm/28 pF.

Indgangskobling. AC/DC/STEL.

Max. indgangsspænding: 400 V DC eller AC spids.

X-AFBØJNING

Tidsbase: 18 kalibrerede trin fra 0,5 sek/cm til 1 μsek/cm i 1–2–5 sekvenser.

X-ekspansion: Med X 10 omskifter opnås max. 100 ns/cm og 3:1 finkontrol giver 1,5 sek/cm.

Nøjagtighed: Bedre end 5 %.

TRIGGEREGENSKABER

TRIGGERMULIGHEDER:

I Intern Y₁ + eller ÷. II Intern Y₂ + eller ÷

III Ekstern + eller ÷

TRIGGERKOBLING:

AC, ACF og TVF.

TRIGGERNIVEAUKONTROL:

Variabel niveauekontrol med klart lysende spor uden indgangssignal.

FØLSOMHED:

I Intern 2 mm ca. 40 Hz – 2 MHz II Ekstern 1 V ca. 40 Hz – 2 MHz

III Intern 1 cm ca. 8 Hz – 10 MHz IV 5 V ca. 8 Hz – 10 MHz

KALIBRERINGSSPÆNDING: 1 V ± 2 % firkant netfrekvens.

Rampeudgang: 0–10 V.

Z-modulation indgang AC-koblet 10 V giver synlig modulation.

GENERELLE DATA

STRØMFORSYNING: 95–111 V/103–121 V/111–130 V/190–222 V/206–242 V/222–260 V.
45–440 Hz.

FORBRUG: Ca. 25 VA.

ARBEJDSTEMPERATUROMRÅDE: 0–50° C (15–35° C for fuld nøjagtighed).

MÅL: Højde 18 cm, bredde 29 cm, dybde 42 cm.

VÆGT: 7 kg.

Februar 1974

SKODSBORGVEJ 305

SG METRIC

INSTRUTEK

HOUMANNSGADE 41. 8700 HORSSENS
TLF (05) 62 71 77. TELEX 6 16 56

HELSINGFORS: TLF. 46 08 44 – OSLO: TLF. 28 26 24 – STOCKHOLM: TLF. 82 04 10