

HP Archive

This vintage Hewlett Packard document was preserved
and distributed by

[www. hparchive.com](http://www.hparchive.com)

Please visit us on the web !

On-line curator: Glenn Robb

This document is for FREE distribution only!

Analysis of Spread Spectrum Signals Using a Time & Frequency Analyzer

**David Chu
R.F. Schneider
Santa Clara Division**

**RF & Microwave
Measurement
Symposium
and
Exhibition**

 **HEWLETT
PACKARD**

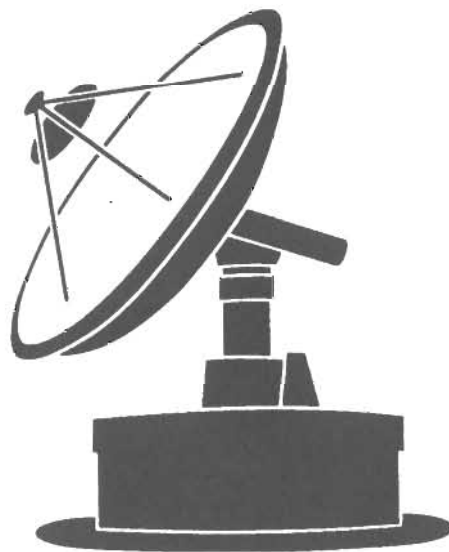

ABSTRACT

The traditional method of capturing a non-repetitive spread spectrum signal is by digitizing its waveform. This paper describes an alternate and more efficient method based on digitizing the phase progression of the signal using counters which can be read on-the-fly. By curve-fitting the data, both carrier(s) and modulation, including FSK, PSK, Chirp and AGILE, can be recovered.

Analysis of Spread Spectrum Signals Using a Time & Frequency Analyzer

David Chu
R. F. Schneider
Santa Clara Division

Examples of Spread Spectrum Signals

Waveform Coding

- Radar
 - Barker (Pulse BPSK)
 - Polyphase (eg. Frank)
 - Chirp
 - Stepped (Pulse to Pulse)
 - PRF Jitter, Stagger
- Jamming
 - Repeater Jammers
- Communications
 - FSK, PSK
 - QAM, QPR

Frequency Coding

- Random or Pseudo-Random Frequency Agility
- Spot Frequency
- Velocity Gate Pull Off
- Pseudo-Random Frequency Hopping

EXAMPLES OF SPREAD SPECTRUM SIGNALS

Modern Radar, Communication, and Navigation systems use spread spectrum signals to enhance system performance. Modern radars require high resolution that is obtained by spread spectrum waveform coding such as Barker (Pulse BPSK), Polyphase (Frank), Chirp (Linear FM Pulse), Stepped (pulse to pulse), and Pulse Repetition Frequency (PRF) Jitter or Stagger. To prevent identification and jamming, frequency coding with random or pseudo-random frequency agility of the carrier frequency is implemented.

Jamming may occur with spot frequency emissions or with repeater techniques. Velocity gate pull off, for instance, deceives the radar by simulating a false target by slowly modifying the frequency of the jamming pulse.

Communication and navigation systems use spread spectrum waveform coding such as FSK, PSK, QAM, or QPR. To secure the communication and navigation links, frequency coding with pseudo-random frequency hopping is used to prevent interception or jamming.

Pseudo noise coding of the waveform (direct sequencing) spreads the data at a rate greater than the symbol modulation rate. Frequency hopping can be fast where the frequency changes after each symbol, or slow where the frequency is changed after several symbols. Some satellite communication systems use Dehop-Rehop (DRT) or Symbol Regenerative Processing (SRP) where each symbol is remodulated and rehopped.

The measurement of these signals is extremely difficult and is the reason for the complex modulation schemes. Measurement requires a very wide bandwidth for frequency agility or hopping. To capture the non-repetitive random or pseudo-random modulation, an ability to resolve instantaneous phase, frequency, or amplitude is needed. Perturbations of pulse or CW signals (even with agility or Hop) need to be measured and an estimate of carrier frequency (even with suppressed carrier) is required.

MEASUREMENT EXAMPLES

This chart gives examples of the measurement requirements of spread spectrum signals:

Intrapulse measurements measure signal parameters within a pulse. Instantaneous (initial, transient, and final) values of phase, frequency, width, and amplitude of each Bit or Chip are needed. This may be made more complex by the presence of random frequent agility (radar) or pseudo-random frequency hopping (communications).

Interpulse measurements compare signal parameters between pulses. Again, the signal may have complex modulation and may also be agile or hopping.

For example a 13 BIT coherent barker coded radar with pseudo-random frequency agility would require measurement of the intrapulse phase/time modulation, unintentional modulation, instantaneous frequency, and pulse width modulation. The interpulse parameters are pulse to pulse coherency, frequency agility, jitter analysis, and carrier frequency estimation.

Measurement Examples	Intra Pulse or Frame			Inter-Pulse/Frame						
	Phase/Time Modulation	Amplitude Modulation	Instantaneous Frequency	Chirp Frequency	Pulse Width Modulation	Frequency Coherency	Carrier Freq Estimation	Jitter Analysis	Carrier Freq Estimation	Jitter Analysis
Barker, PolyPhase	✓		✓	✓	✓	✓	✓	✓	✓	✓
Chirp Radar	✓		✓	✓	✓	✓	✓	✓	✓	✓
Stepped Freq Radar			✓	✓	✓	✓	✓	✓	✓	✓
Deception Jammer	✓	✓	✓	✓	✓	✓	✓	✓	✓	✓
FSK Communication		✓	✓	✓	✓			✓	✓	✓
PSK Communication	✓		✓	✓				✓	✓	✓
QAM Communication	✓	✓	✓					✓		✓

CURRENT MEASUREMENT METHODS

Measurement of spread spectrum signal performance can be made with waveform recorders, digital oscilloscopes, vector analyzers, spectrum analyzers, and frequency/time counters.

Lets Quickly Review These Methods

WAVEFORM RECORDERS

A waveform recorder is a "Real Time" digitizer. "Real Time" digitizers sample at greater than the Nyquist rate and can measure non-repetitive or single shot signals. The input bandwidth is limited by an anti-aliasing low pass filter before digitizing. Optimum digitizing efficiency occurs when the allowable signal spectrum is from DC to the filter cut off frequency.

Digitizing signals at a high sampling rate with good voltage precision (bits of resolution) is a difficult hardware problem. "Real-Time" digitizers can be used to measure the statistical variations in repetitive signals or to capture single shot transients. The amplitude resolution reveals the waveshape of the signal and the digitized data is in the exact form for digital signal processing.

A recent example of a waveform recorder is the HP 5185 that has a 250Msamples/s, and 110 MHz bandwidth with 8 bits of resolution. Some digital oscilloscopes sample fast enough to be considered waveform recorders for purposes of this paper.

DIGITAL OSCILLOSCOPES

A digital scope is an "Equivalent Time" digitizer. "Equivalent Time" digitizers under sample the signal and require a repetitive signal to reconstruct the waveform.

The input signal hardware must have enough bandwidth to preserve the original waveform prior to sampling. The "Equivalent Time" technique compresses the input spectrum to a low frequency spectrum that is digitized as a time expanded version. If the information bandwidth of the signal is greater than half the sampling rate, aliasing occurs and the sampled signal is distorted. Once under sampled, no digital filtering can undo the damage; but an adequately sampled noisy signal can be enhanced by digital signal processing.

The resolution of the signal level is dependent on the A/D bit resolution. Digital oscilloscopes using electro-optics or Josephson Junction sampling may have 100 GHz bandwidth frequency range but only 100 kHz bandwidth due to undersampling. Recent digital oscilloscopes such as the HP 54120T have 20 GHz bandwidth and 10 psec accuracy. The HP 54111D has a 1 Giga-sample/second digitizing rate, a 500 MHz repetitive bandwidth and a 250 MHz single-shot bandwidth with up to 8 bits of resolution.

Current Measurement Methods

- Waveform Recorders
- Digital Oscilloscopes
- Vector Analyzers
- Spectrum Analyzers
- Frequency/Time Counters

Waveform Recorders

- A Waveform Recorder is a "Real Time" Digitizer
- Digital Signal Processing provides analysis of Non-repetitive signals.
- Must Sample at greater than Nyquist to preserve signal
- Digitizing at a high rate with high precision is difficult

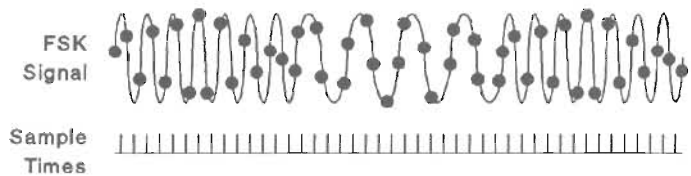

Digital Oscilloscopes

- A Digital Oscilloscope is an "Equivalent Time" Digitizer
- Under-Sampling requires a Repetitive Signal
- Capable of GHz Frequency and pSec Time measurement

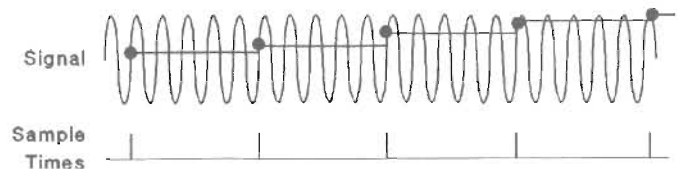

VECTOR ANALYZERS

The Vector Analyzer measures baseband I and Q channels of a coherent detector or demodulator. It analyzes coherent phase and amplitude and provides timing measurements.

Current products use "Equivalent Time" digitizers so that repetitive signals are required. The spread spectrum signal must be Vector demodulated with a phase coherent LO source to generate the I and Q channels as shown in this figure:

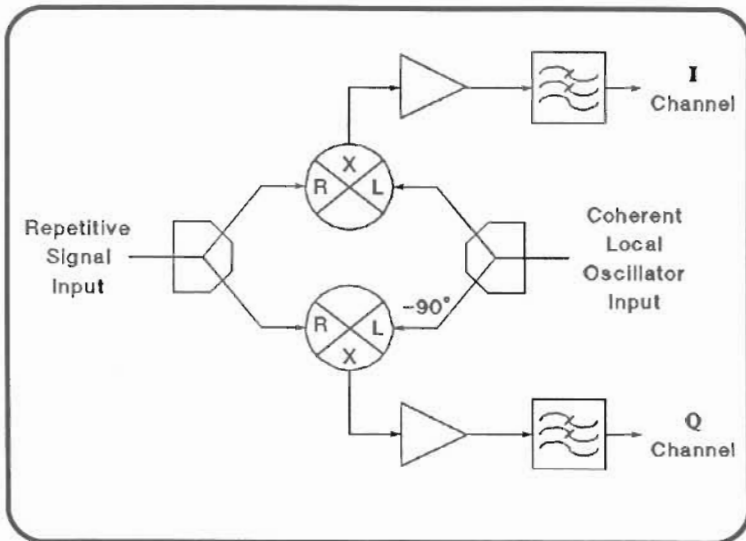

Vector Analyzers

- Current products use Equivalent Time Digitizers
- Repetitive Signals are required
- Require I and Q signals and a coherent L.O.
- Offer Amplitude and Phase measurements

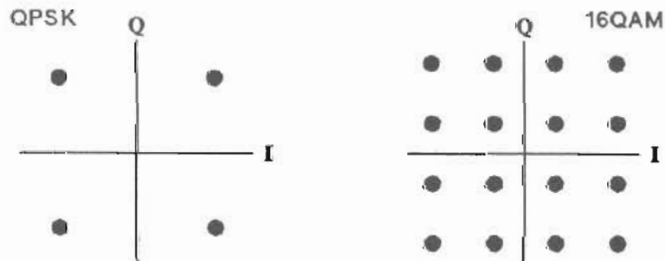

Since the "I" (or in-phase channel), and the "Q" (or quadrature channels) are digitized, accurate repetitive measurements of signals are made and can be displayed on a constellation display as shown for a QPSK and 16QAM signal.

Spectrum Analyzers

- Offers Broadband Frequency coverage and provides Signal Analysis in the Frequency Domain
- Requires a Repetitive Signal
- Provides Fourier Analysis of AM, FM, or PM Modulation
- Provides Spur and Harmonic Level analysis
- Timing measurements are difficult to make

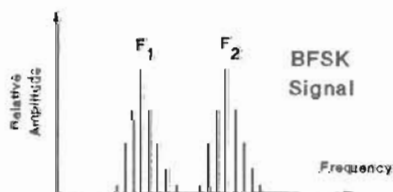

SPECTRUM ANALYZERS

Spectrum Analyzers use the frequency-conversion properties of the swept-tuned heterodyne receiver to perform frequency domain signal analysis. They offer broadband frequency coverage and provide for the Fourier analysis of AM, FM, PM or pulse signals. Absolute and relative frequency and amplitude measurements can be made. Because of the wide dynamic range of the input, it also provides spur and harmonic level analysis.

Spectrum analyzers can be used in the fixed-tuned mode (zero-span) to provide time domain measurement capability. A repetitive signal is required and the IF bandwidths are usually low. A single-shot event may be missed if the analyzer is not tuned to the input signal at the time of the event like for agile or hopping signals. The display of a BFSK signal requires interpretation to analyze the signal.

FREQUENCY/TIME COUNTERS

Frequency/Time Counters can measure single-shot time intervals to 20 psec. Frequency extension is available to 100's of GHz but extracting accurate phase information may require local oscillator spectral purity beyond that of the counter's built-in L.O. The traditional counter has a reset or dead time so that the digital data may be missed resulting in a low modulation rate capability. Also, since the measurements are not time referenced to each other the modulation data is lost. Frequency/Time Counters are the most accurate measuring instrument for the frequency and time parameters.

The BFSK signal is shown synchronous with the dead time of the counter to illustrate the measurement problem. This spread spectrum signal could easily be measured by the counter by externally gating during the F1 and F2 intervals. To do so, however, would require a repetitive signal to overcome the dead time problem.

SUMMARY

To measure non-repetitive agile or hop signals with complex modulation a new approach is necessary!

Frequency/Time Counter

- Can make some Non-Repetitive Signal measurements
- Traditional Counters have a measurement "Dead Time", and measurements are not time referenced to each other, so modulation data is lost
- Frequency Extension to 110GHz possible, but current Counter's local oscillator may not be adequately stable to resolve required phase measurements

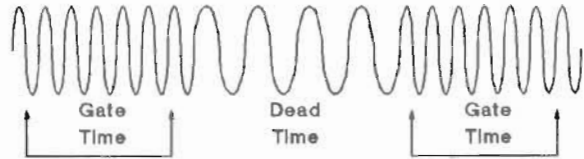

- Waveform Recorders
 - Works on Non-repetitive Signals
 - Must sample at greater than Nyquist rate
- Digital Oscilloscopes
 - Needs Repetitive Signal
- Vector Analyzer
 - Needs Repetitive Signal and coherent L.O.
 - Works on I/Q Signals; or coherent carrier
- Spectrum Analyzers
 - Needs Repetitive Signal
 - Timing measurements difficult to get
- Frequency/Time Counters
 - Dead Times hamper measurement of Non-repetitive Signals and modulation data is lost

A New Approach

Phase Digitizing

Waveform vs. Phase Digitizing

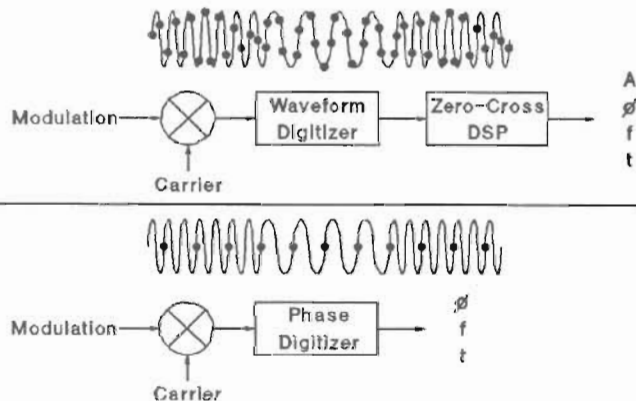

Voltage Digitizer (Waveform Recorder)



Phase Digitizer

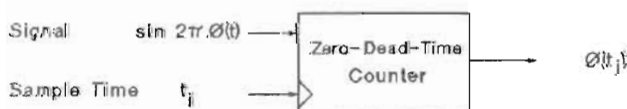

Hence the parallel is complete: for the same signal being sampled at the same time values t_i , one digitizer gives voltage values $\sin[2\pi\phi(t_i)]$ and the other phase values $\phi(t_i)$.

A NEW APPROACH

Up to now, the only practical way to capture a non-repetitive signal has been to digitize it. To do so, however, one must sample at the Nyquist rate for waveform preservation. For a modulated signal, that is at least twice the carrier frequency plus the instantaneous bandwidth. Since the instantaneous (information) bandwidth is always less and sometimes much less than the waveform bandwidth, such a high sampling rate is fundamentally unnecessary. Furthermore, FSK or PSK modulation information lies only in the signal phase. Voltage samples must be translated into phase information, a cumbersome task at best.

We offer a completely new approach. We bypass the extra waveform digitizing step and digitize the phase of the signal directly. We call it "Phase Digitizing" and it is made possible by a patented technique of reading unambiguously a high-speed counter on-the-fly without disturbing the counting process. We will discuss many additional bonuses offered by this approach.

WAVEFORM VS PHASE DIGITIZING

This diagram illustrates the two processes of Waveform Digitizing and Phase Digitizing. In waveform digitizing, samples are taken at regular preset intervals. They do not necessarily fall on zero-crossings. To find those, DSP interpolation algorithms are needed to obtain voltage values around a zero-crossing. From these interpolated points, linear approximation or an iterative techniques can be used to finalize the zero-crossing time.

In phase digitizing, the values of zero-crossing times are directly measured and digitized. Notice only positive crossings are digitized, and not every one is. The ones which are digitized are tagged with their count number, called Event. Each event is also time-tagged. From the Event and Time values, frequency, phase and time parameters can be computed. Amplitude information is lost.

There are always fewer samples in phase digitizing than in waveform digitizing. In waveform digitizing, there are several samples per carrier cycle regardless of modulation. In phase digitizing the sampling rate is determined only by the modulation bandwidth, not by the carrier frequency.

MATHEMATICAL MODELS OF THE VOLTAGE DIGITIZER AND THE PHASE DIGITIZER

Here we show how a Zero-Dead-Time (ZDT) counter, i.e. a counter which can be read repeatedly on-the-fly, can be viewed as a phase digitizer. To do this, we compare it side-by-side with the more familiar voltage digitizer (quantizer).

The voltage digitizer has an input, to which is fed a signal such as a sinusoid with some complex phase modulation in the, represented by $\sin[2\pi\phi(t)]$. It has a sampling trigger input which is activated repeatedly at times $t = t_i$. Every time that happens, the signal voltage at t_i appears at the output in numerical form as $\sin[2\pi\phi(t_i)]$.

In comparison, the ZDT-counter is fed the same signal and is similarly triggered to sample (read) repeatedly at $t = t_i$. Since count is simply phase progression, 1 count being 2π radians or 360 degrees, the count at the output is the instantaneous phase value evaluated at times t_i , or $\phi(t_i)$.

PHASE DIGITIZING A BFSK SIGNAL

Here we have an example of a measurement using Phase Digitizing. A BFSK signal is shown with the modulating signal. The phase digitizing sample locations are shown by the dots. There are two numbers associated with each sample, the Event count and the Time stamp. Notice that in the low frequency regions, every cycle is sampled, the Event number increases by 1 per sample. In the high frequency regions, only every other cycle is sampled, and the Event number increments by 2. The time values, in this example, are rounded to 1 nS.

Frequency can be computed by change in Event divided by change in Time, where the changes can be taken between any two samples. In the example, we take two adjacent samples in the low frequency region and get 50 MHz. Taking two adjacent samples in the high frequency region, we get 100 MHz.

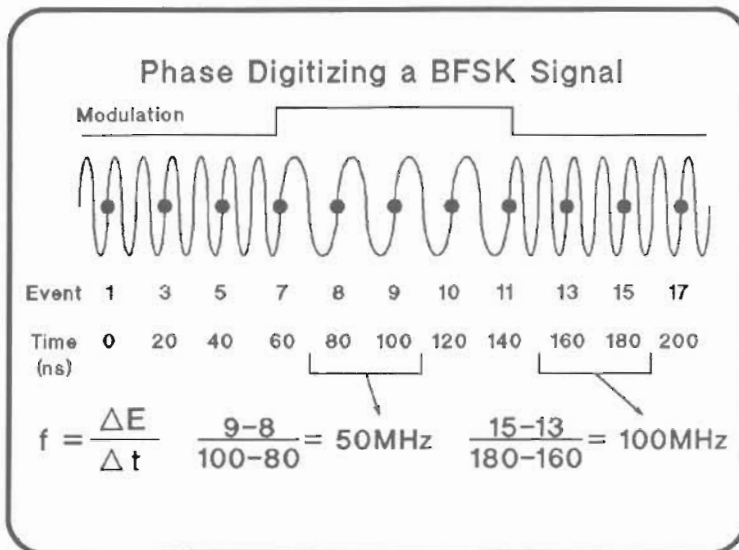

SIMPLIFIED PHASE DIGITIZING COUNTER

This is a block diagram showing how two ZDT counters are connected to produce Event and Time Data like those shown in the previous example. With each sample command, a synchronizer (D flip-flop) generates an edge which is synchronous with a signal positive transition. The edge is used to trigger both the Event and Time ZDT counters. For the Event counter, signal and trigger are synchronous, and therefore there is NO error. Event data is therefore exact, not plus-or-minus one. In the Time ZDT shown, the signal is a 500 MHz time base clock. Each edge at the sample command is therefore time-stamped by the running clock to 2 nS precision. Using time interval interpolating techniques, the 2 nS resolution can be refined to 200 pS.

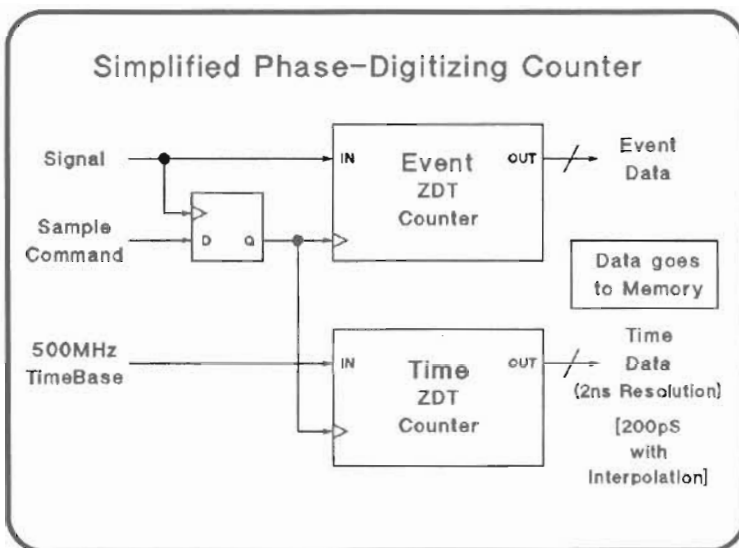

PHASE PROGRESSION PLOT FOR IDEAL CW SIGNAL

Since for each sample, we get two numbers, Event and Time, it is most instructive to plot them out as rectangular co-ordinates and observe the graph generated by various signals. The vertical axis is Event, which is actually the phase progression of the signal. Each count or Event means the signal has progressed by 360 degrees. We plot this progression against the time taken shown on the horizontal axis. A constant frequency means equal phase progression in equal time, hence a straight line is generated on the Phase Progression Plot. The frequency of the signal is given by the slope of the line. A vertical translation of this line corresponds to a phase shift. Events occur only in integer values, but the time values are as fine as the instrument's time resolution.

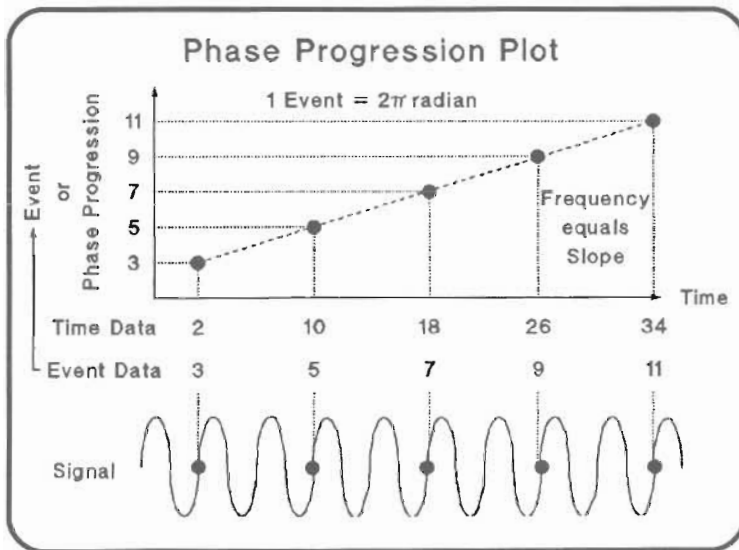

Calculating Frequency from Curve Fit

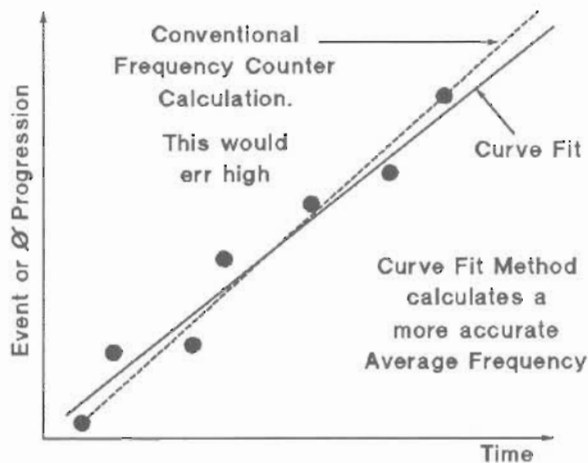

CALCULATING FREQUENCY FROM CURVE FIT

Here we show a phase progression plot of data which resemble those from real life. From the corrupted data, we would like to estimate the (average) frequency of the signal. The corruption may be due to many sources, such as quantization, trigger noise, phase noise, or random modulation. We can use statistical methods to find a "best fit" straight line near the data points. The slope of this curve fit gives the "best" estimate of the frequency.

It is interesting to note that a traditional frequency counter can be illustrated this way. However, it has only two points, the first and the last, corresponding to the opening and closing of the gate, and no intermediate points. The frequency estimated by the traditional counter is given by the line joining these two end points. For white noise, statisticians called independent identically distributed (i.i.d.) noise, not unlike that generated by quantization, the curve fit method is a significant improvement over the end point method, by the ratio of the square root of the number of points.

Calculating Deviations

Step 1:

Calculate Curve Fit.

Step 2:

Calculate deviations from curve fit.

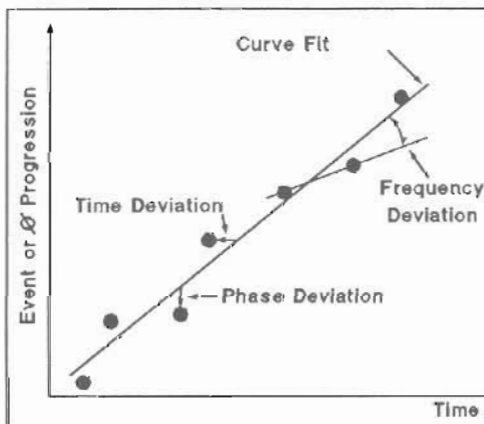

CALCULATING DEVIATIONS

Besides using the curve fit for estimating average parameters, we can use it for another very important function -- the calculation of deviations, both intentional (modulation) and unintentional (error). Here we show the data points alongside their curve fit. The slope of the line gives the average frequency, and its y-intercept is directly related to the average phase value. There are three principal deviations we can get from comparing data points against the curve fit:

- 1) The vertical distance from point to curve is phase deviation. By computing this for every point, we can measure phase deviation as a function of time.
- 2) The horizontal distance from point to line is a time deviation, and that can also be measured as a function of time.
- 3) The slope of adjacent, or neighboring, data points can be computed against the derivative of the curve at the location. This will provide frequency deviation. For an FM signal, for example, the curve fit will give carrier information, and the deviation will be the frequency modulation.

BFSK

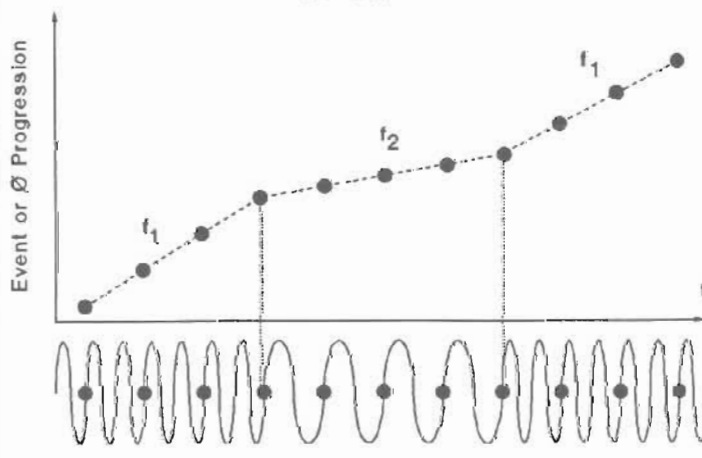

BFSK ON THE PHASE PROGRESSION PLOT

Let us re-visit the BFSK example once more and see the graph it generates on the phase progression plot. Just as expected, you see piecewise linear curves with two different slopes, corresponding to the binary frequency.

Since a sample must coincide with a positive zero-crossing, sampling does not occur perfectly uniformly in time in general, as the diagram may unfortunately imply. The diagram does show correctly; however, that sampling rate is relatively constant with changing signal frequencies, because the number of Events between samples will automatically change with frequency. There will be more with high frequency and less with low. Sampling will stop automatically when a signal is absent.

BPSK ON THE PHASE PROGRESSION PLOT

A BPSK signal is a constant frequency signal but its phase shifts by 180 degrees with the modulating signal. On the phase progression plot, we see straight lines periodically shifted down (could be up in other examples) by half a count. When it is shifted twice, it is 360 degrees, or the same as 0 degrees.

To be truthful, the lines actually do not move down, but rather to the right by an additional half a carrier period in time for each shift, while advancing by whole numbers in the Event or phase progression. As a result, the line appears to have moved "down" by half a count. For curve fitting, the data points are mapped to the nearest one of a set of parallel lines which are spaced at 1/2 count apart. Residual difference provides phase error data.

Needless to say, the generalization to MPSK is immediate. For QPSK, for example, the jumps will be in 1/4 count increments instead of 1/2.

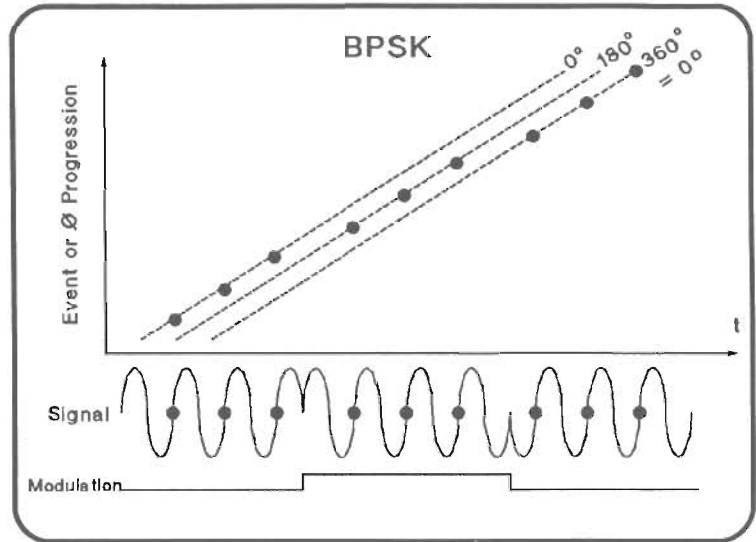

PULSED RF

The phase progression plot of a pulsed rf signal is shown here. It consists of parallel lines (assuming same frequency in the bursts) separated horizontally from each other. Strictly speaking the separation is not completely horizontal since there is a progression of at least one count from the end of one to the beginning of the other. The most interesting thing about pulsed rf is that there are no samples where there are no signals. Phase digitizing automatically adapts itself not to waste samples on regions of no activity and therefore no interest. On the other hand, if there are transient phenomena occurring during supposedly quiet periods, samples will be generated showing exactly when and how many.

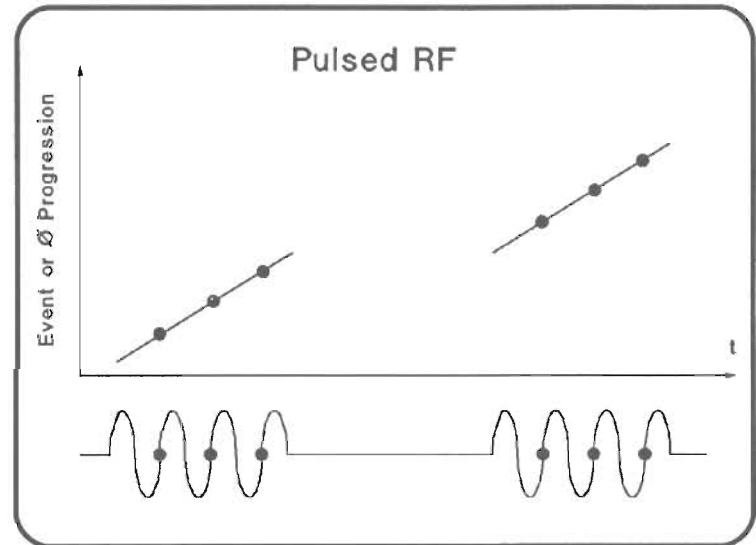

CHIRP (LINEAR FREQUENCY CHANGE)

A chirp is a signal whose frequency varies linearly with time. Since phase is the integral of frequency, the phase progression plot is quadratic with time. As a result, the graph generated by an ideal frequency chirp is a parabola on the phase progression plot. To measure nonlinearity in a chirp, we do a quadratic fit to the data. Non-linearity can be measured, as always, by subtracting data from curve fit to obtain phase, time and frequency deviation data.

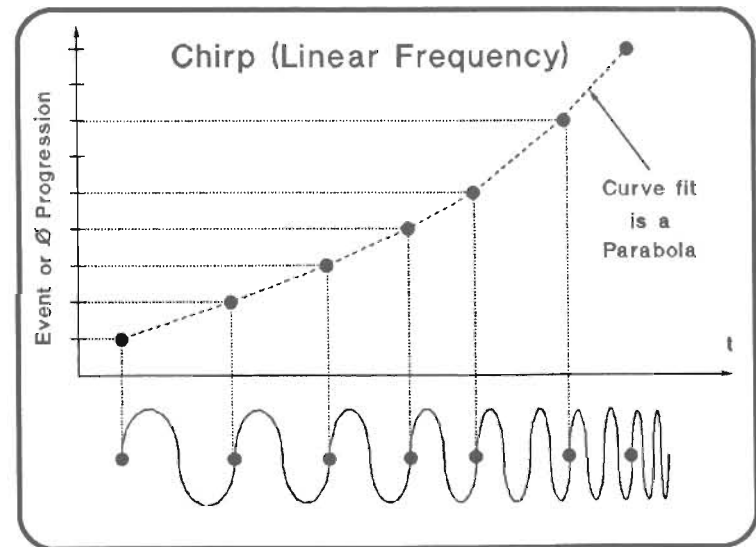

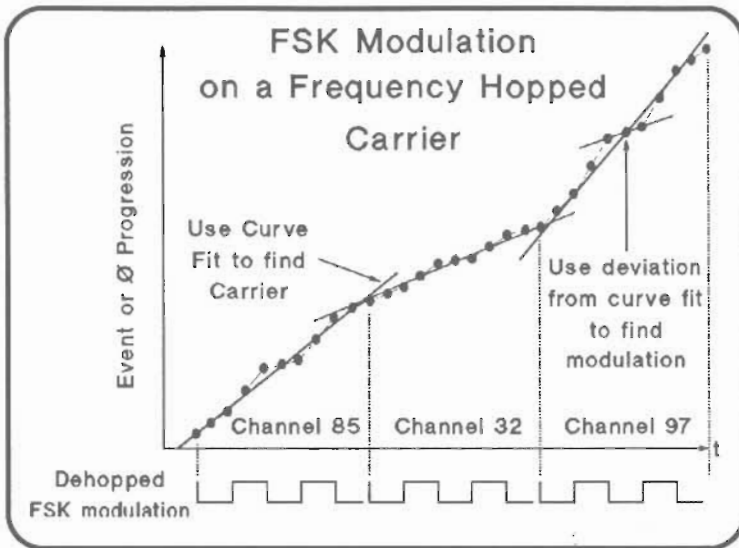

FSK MODULATION ON A FREQUENCY HOPPED CARRIER

Here we show the phase progression plot of a FSK signal on a frequency hopped carrier. The dehopped FSK modulation is simultaneously shown on the bottom graph. We use straight line curve fit to identify three regions of different carriers, given by the slopes of the 3 major lines. Subtraction of the data from the corresponding curve gives rise to phase deviation data. By performing a digital differentiation on the phase deviation, the FSK signal is revealed.

HP5371A Frequency and Time Analyzer

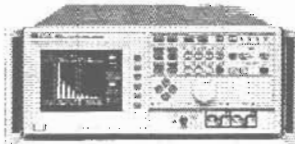

- 500 MHz maximum input
- 200ps single-shot resolution
- 10 MSa/s Sample Rate
- 1k - 4k Sample Memory
- 2 Channels
- Internal & External Arming
- Statistics, including Histograms, Allen Variance
- HP-IB

HP5371A FREQUENCY AND TIME ANALYZER

This is an embodiment of a Phase Digitizer, the HP5371A Frequency and Time Analyzer. Basically it has two independent phase digitizing channels with the same time base clock. It can capture data for all the single channel measurements mentioned. In addition it can time relate data from two separate signals. Measurements such as non-modulo 2π phase differences can be made. A summary of the key specifications is listed. Its statistical capabilities are not discussed in this paper. With the basic Analyzer, one can measure a carrier hopping or chirping range up to 500 MHz. The system is DC coupled, low frequencies present no problem. The 10 MSa/s rate can accommodate instantaneous bandwidth of 5 MHz.

Examples of Measurements Made with the HP5371A

EXAMPLES OF MEASUREMENTS MADE WITH THE HP5371A.

To put into practice the ideas discussed, we have written some software to make measurements of spread spectrum signals with the 5371A and store the data into files through HP-IB. To analyze the data files, different curves are fitted to the data for different modulations types. Average and deviation parameters are computed as described in this paper. The final results are displayed. We will show a few of these to illustrate the power of phase digitizing real life signals.

ACTUAL CHIRP WITH FREQUENCY DEVIATION

This is a display of a chirp signal captured by the 5371A. The top graph shows the frequency chirp from about 200 MHz to just under 400 MHz in 65 μ s. Actually there are two graphs on top, the data and the fitted curve. They are, however, not distinguishable on this scale. The bottom curve shows the frequency deviation from linearity, some non-linearity is visible in spite of limited frequency resolution from computation with just two or three adjacent data points.

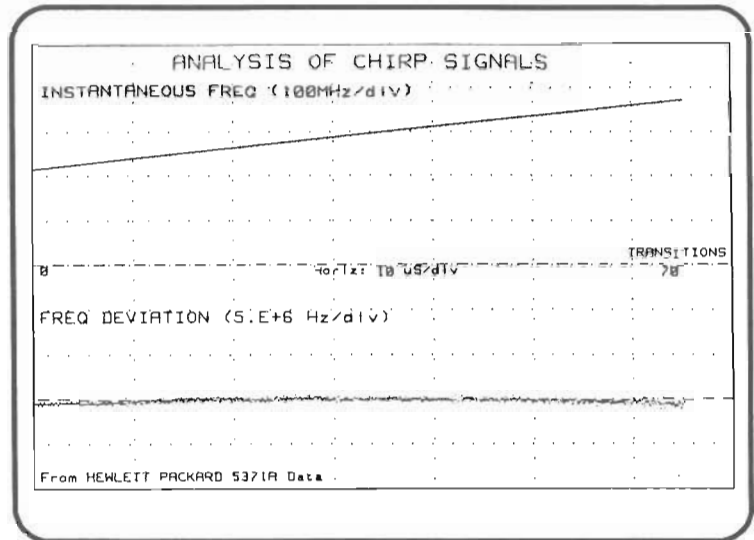

ACTUAL CHIRP WITH PHASE DEVIATION

This is a display of the same chirp signal except phase deviation is shown on the bottom. The non-linearity, totally invisible in the frequency vs time graph on top, and barely suggested by the frequency deviation in the last graph, can now be seen with clarity in the phase deviation graph. The phase nonlinearity is over 500 degrees in both directions. Phase deviation is superior to frequency deviation because phase is a direct measurement and frequency is a computed parameter from phase data.

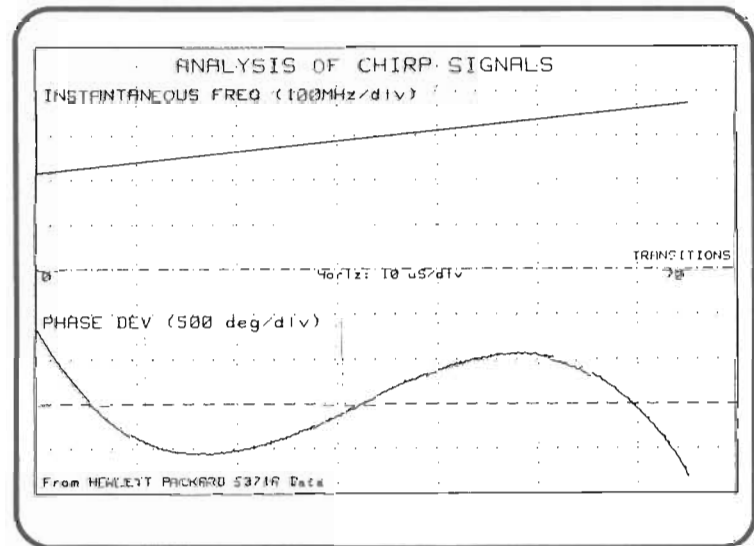

ACTUAL CHIRP WITH TIME DEVIATION

Yet another way to observe nonlinearity is to observe the time deviation shown on this display. Again the top graph is the same but the lower graph shows timing nonlinearity well over 5 nS in each direction. An interpretation of time nonlinearity is that the zero-crossings occur sooner or later than those of an ideal chirp by the amount displayed. Timing deviation is the "horizontal" difference between data and parabola.

Different nonlinearity measures are preferred by different workers in radar. The signal shown in these three graphs was captured in a single pass into about 700 samples.

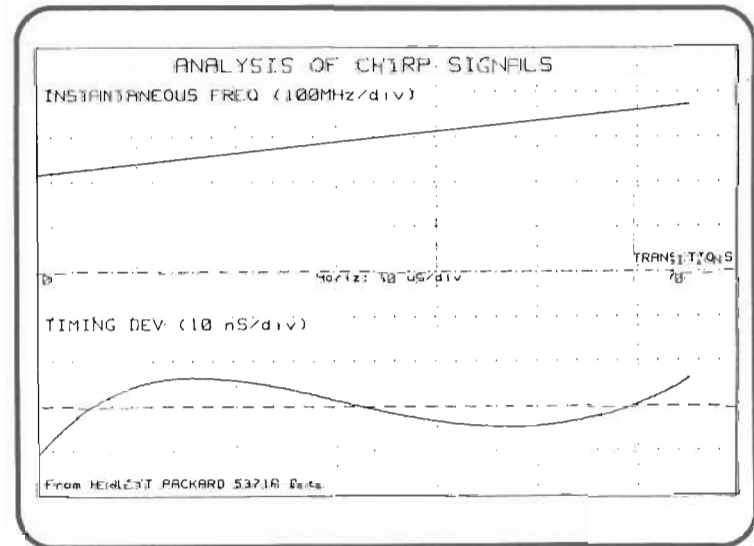

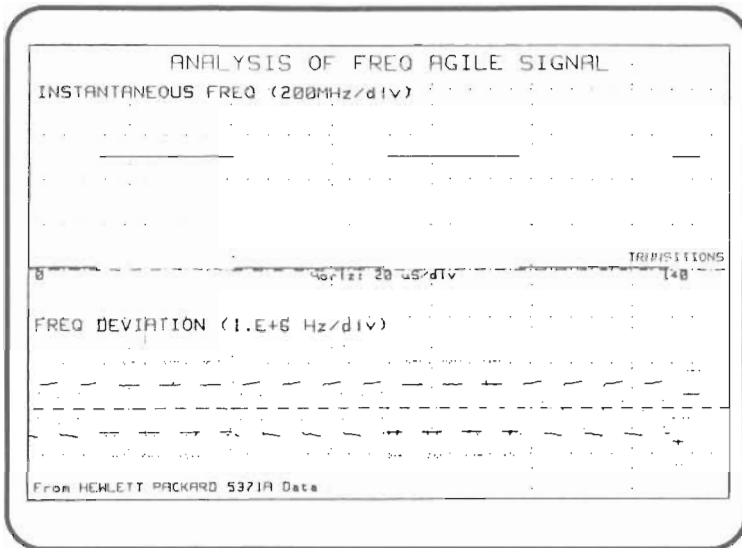

ACTUAL FREQUENCY AGILE CARRIER WITH FSK, DEHOPPED FREQUENCY MODULATION

This graph shows the result of analysis on a frequency agile signal with FSK modulation. The top curve shows the instantaneous frequency of the signal and the fitted curve for the carrier estimation. It is seen that the carrier hops between 10 MHz and 490 MHz. The small difference between data and curve is due to modulation.

The bottom curve shows the de-hopped FSK modulation which is simply the magnified difference between the two top curves. The signal lasted 140 uS and was captured in one shot of 1000 samples.

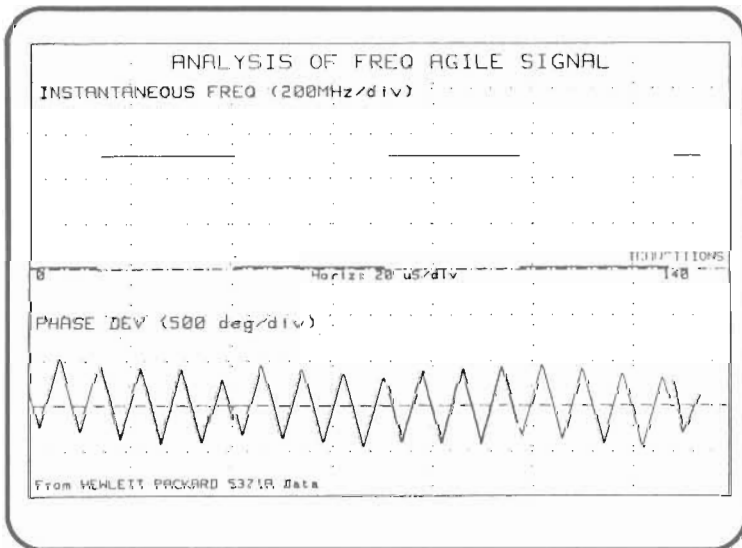

ACTUAL FREQUENCY AGILE CARRIER WITH FSK, DEHOPPED PHASE MODULATION

The same signal is displayed but here the phase deviation between data and estimated carriers is displayed on the lower curve. Since it is a BFSK modulation, the phase deviation will appear as triangular wave. Just as in the chirp case, phase deviation usually shows better than frequency deviation. The two carrier frequencies are accurately determined from the data.

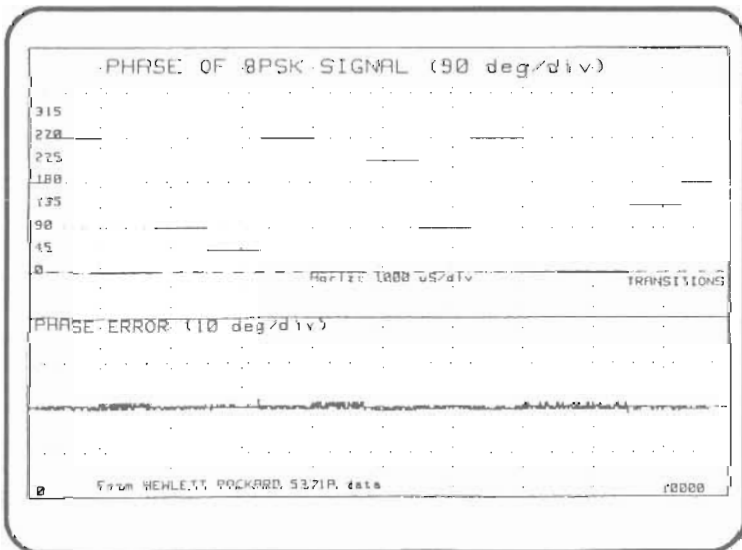

ACTUAL 8PSK SIGNAL

We show the analysis of a 8PSK signal. The top graph shows the demodulated signal switching among the 8 possible phase states with time. Since there is no coherent local oscillator used, the phases are accurate to within an arbitrary constant. The carrier frequency, a 10 MHz signal, is computed from the data. The lower graph shows that the signal phase hops are perfect to within the resolution of the 5371A Analyzer, which is .7 degrees at 10 MHz. The signal lasted 10 mS, and was captured in one pass into 1000 points.

With the same technique, we also captured and analyzed a 16QAM signal. There are 12 unevenly spaced but known phases for the 16QAM signal. We demodulate the signal to the nearest phase and show the residuals. Since amplitude information is absent, only phase and phase error can be measured for the 16QAM.

ACTUAL BARKER CODED BPSK PULSED SIGNAL

This graph shows 8 pulses of a train of Barker coded BPSK signal. The carrier is at 3.1 GHz but down converted to an IF of 100 MHz. Phase is preserved in the heterodyning process and hence the IF signal has the same binary phase characteristics of the microwave signal. The 100 MHz carrier was computed from the 1000 data points captured in one pass. The intervals between pulses are shown as "Transitions". There are no samples in them, and no phase values are shown.

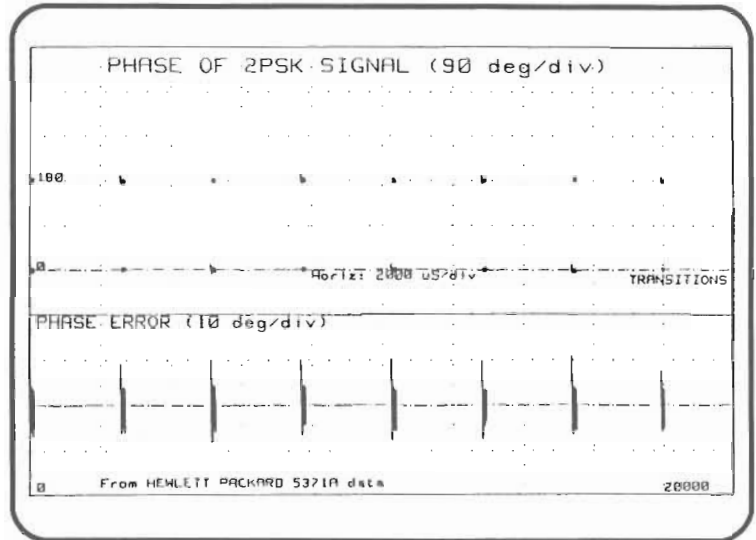

ACTUAL BARKER BPSK, ZOOMED TO 1 PULSE

By zooming in on one pulse, the 13-bit Barker coded BPSK can be seen. The lower curve shows residual phase errors of the signal. Again, phase is known to within a constant.

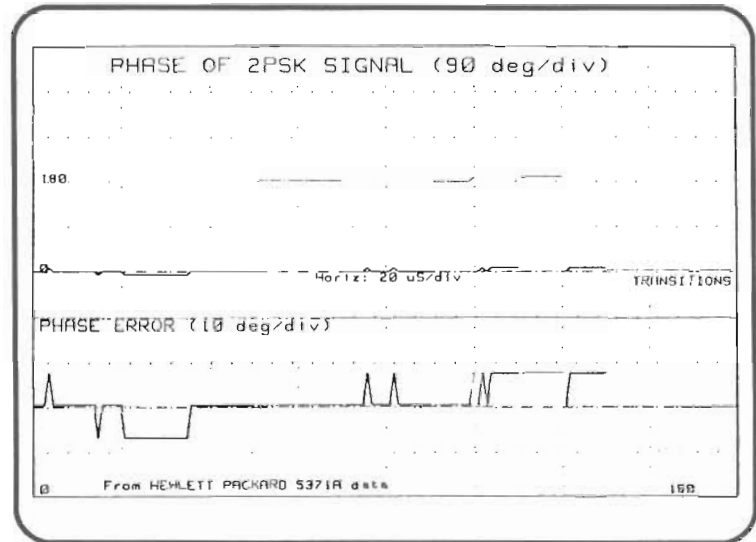

ACTUAL BARKER BPSK, WITH LO OFFSET

We offset the Local Oscillator to the downconverter by 111 kHz, an arbitrary choice, and repeated the measurement. This graph shows the same binary phase Barker signal. The IF carrier frequency, however, is now 100.111 MHz.

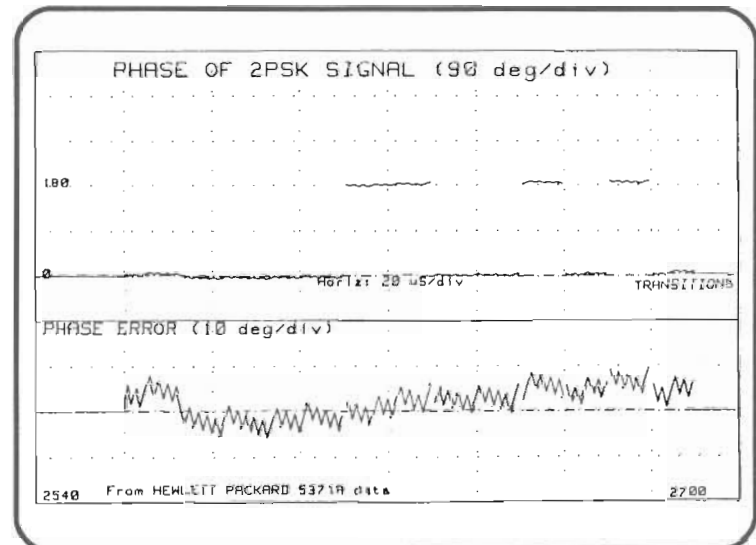

Furthermore...

Phase measurements can be made
Without the need of a
Coherent Local Oscillator!

Frequency Coverage Extension

To Extend
Hopping
Range

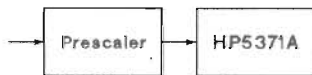

To Extend
RF Range

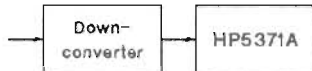

To Extend
RF Range and
Hopping Range



Conclusion

- The HP5371A represents a new measurement concept by directly digitizing the phase of the signal
- A more efficient way to capture non-repetitive spread spectrum signals has been demonstrated

COHERENCE

The last two measurements combine to demonstrate that a pulsed PSK signal can be successfully demodulated by first hardware heterodyning using a stable but arbitrary local oscillator and then phase digitizing the IF signal. The actual demodulation is done numerically by homodyning with a computed IF carrier frequency.

As the duty-cycle of the signal decreases, the accuracy requirement for frequency estimation becomes more stringent. There may be more than one IF which fits the data, especially with noisy signals. If the IF frequency is known, then it can be digitally entered thereby saving computation and removing possible frequency ambiguity. For most cases, however, the computed IF successfully demodulates the signal.

FREQUENCY COVERAGE EXTENSION

To extend the hopping or chirp range, a frequency prescaler can be used. For example, a divide-by-four prescaler will increase the hop range from 500 MHz to 2 GHz. With phase digitizing, all modulated signals discussed, including PSK, can be demodulated after prescaling. Note that with waveform digitizing, the hopping range cannot be so easily extended.

To extend measurements to the microwave region, e.g. 18 GHz, we can use a downconverter to bring the signal to the 500 MHz band of the Analyzer. Here, the local oscillator need not be coherent, only stable, even for PSK signal measurements.

Of course, one can combine a downconverter with a prescaler to bring a wide hopping range to the microwave region.

CONCLUSION

The 5371A represents a new measurement approach by directly digitizing the phase of the signal, instead of digitizing a waveform and translating the voltage data to phase. The benefit of the direct method is greater efficiency with lower sampling rate. It operates in real time and captures non-repetitive frequency- or phase modulated signals with large dynamic carrier frequency range. We believe this is a fundamental measurement concept that is here to stay, along with waveform digitizing and spectrum analysis.

