

5345 ELECTRONIC COUNTER

HEWLETT  PACKARD

MEASURING INTEGRAL NONLINEARITY OF A VOLTAGE CONTROLLED OSCILLATOR

Using the HP 5345 Electronic Counter with the HP Interface Bus allows the counter to interact with a variety of bus compatible instruments to provide capability and versatility previously unavailable. This application note describes the use of an HP 5345 Electronic Counter in a calculator based HP Interface Bus system to automatically measure the integral nonlinearity of a voltage controlled oscillator. Since the system is calculator based and completely automatic, measurement time is much less than that required to perform the measurements and computations manually (typically less than 5 seconds). In addition, the repeatability and accuracy of the measurements are improved over manual methods. Use of the HP Interface Bus ensures that the instruments need not be dedicated to a particular configuration (as in the case of hard-wired systems). The bus allows instruments to be quickly and easily reconfigured to solve the problems encountered in the dynamic environment of production, the R & D lab, or quality control.

INTRODUCTION

Integral nonlinearity gives a measure of the non-linearity of analog devices. The voltage controlled oscillator is an example of a device where this measurement is meaningful. The transfer characteristic (see Application Sheet 174-1), relating input to output, of such a device is shown in Figure 1.

The integral nonlinearity measurement consists of measuring the maximum departure of the transfer

characteristic curve from some straight line fitting through the curve and expressing this as a percentage of full scale. The definition of the reference line is most important since linearity measurements on the same device will produce different results depending upon the definition chosen. Two useful definitions are (1) a line with a slope equal to the average slope of the curve; (2) least squares fit. The latter definition is used in this application sheet. With this definition, integral nonlinearity is defined by Figure 2.

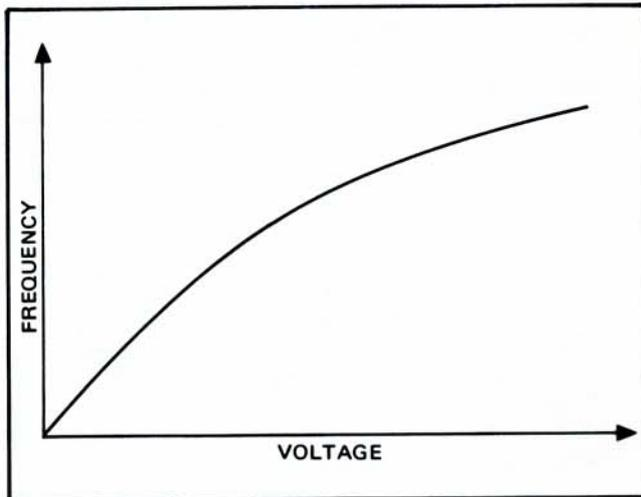

Figure 1. Transfer Characteristic of a VCO

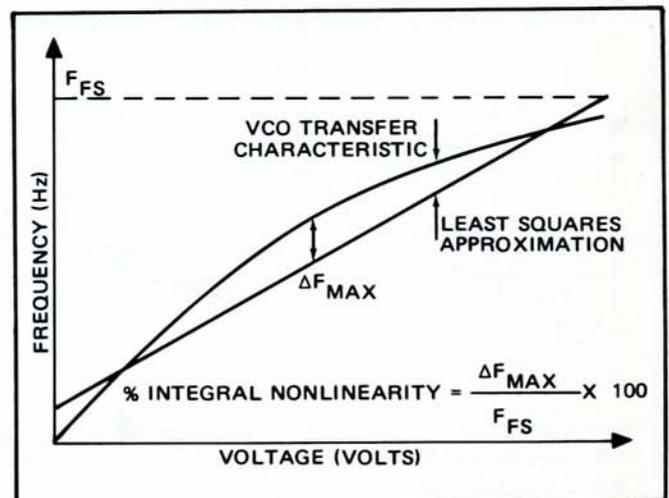

Figure 2. Definition of Integral Nonlinearity for VCO

APPLICATION NOTE 174-3

MEASUREMENT SET-UP

The measurement system consists of the 5345A Electronic Counter (Opt. 011), the 9820A Calculator (Opt. 001 Extended Memory), the ASCII Bus Interface Card and PCII ROM (both included in 10593A), 11221A Math ROM, 11220A PCI ROM, and 59303A Digital to Analog converter. The instruments are connected to the calculator as shown in Figure 3.

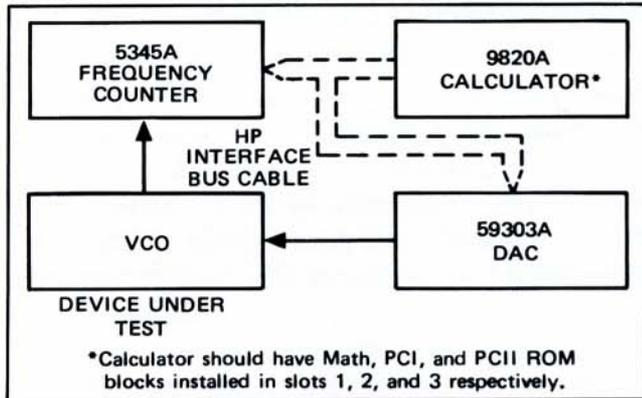

Figure 3. Measurement Set-up

Since the 9820 calculator remotely controls all front panel controls of the D to A converter and frequency counter, there is no need to set these controls to any particular positions. The calculator is electrically interfaced to the 59303 DAC and the 5345A Frequency Counter by connecting ASCII interface cables (10631 A, B, or C) from the rear mounted ASCII bus interface card of the calculator to the rear panel plugs of the DAC and frequency counter. (The ASCII interface card is plugged into any of the four rear panel slots of the calculator).

Set the Talk/Listen addresses on the DAC and the frequency counter as specified in the following table:

Table 1

	Talk/Listen Addresses	Mode Switch	A5	A4	A3	A2
.59303 DAC	/(=program) /<(data)	addressable	1	1	1	0
5345 Counter	J/*	addressable	0	1	0	1

These switches are located on the rear panel of the instruments and must be set so as to agree with the Talk/Listen addresses in the program.

OPERATION

To compute the percent integral nonlinearity of a voltage controlled oscillator, key into the calculator the program listed. The program will request values for the minimum (VMIN) and maximum (VMAX) dc voltages to be applied to the VCO under test (not to exceed the range of the 59303: -9.99 to

+9.99 Vdc). The program also requests the voltage step size (in volts) to be used in going between VMIN and VMAX. After entering a requested parameter through the 9820 keyboard, press RUN PROGRAM.

Under control of the calculator, the DAC presents a dc voltage to the VCO. The 5345 counter measures the VCO output frequency and inputs this to the calculator. The DAC voltage is incremented and this process continues until the requested voltage range has been spanned. After measuring each new frequency, the calculator stores and processes the point (X (volts), Y (Hz)) for use in a 1st order least squares curve fit. It can be shown that to fit a 1st order curve of the form $Y = a_0 + a_1 X$ to a set of n data points (X_i, Y_i), a_0 and a_1 are given by:

$$a_1 = \frac{n \sum X_i Y_i - \sum X_i \sum Y_i}{n \sum X_i^2 - (\sum X_i)^2}$$

$$a_0 = \frac{\sum Y_i - a_1 \sum X_i}{n}$$

In the program, registers R9-R12 are used to accumulate the sums of X_i , Y_i , X_i^2 , and $X_i Y_i$, respectively. After the voltage range has been spanned and the collection of n data points has been completed, a 1st order least squares curve is computed. For each value of X (volts), a Y (frequency) is computed from the least squares curve and compared with the stored actual value. The maximum difference between the computed and the corresponding actual value is found and used to calculate the percent integral nonlinearity. This value is printed out on the 9820 printer.

MEASUREMENT CONSIDERATIONS

- The gate time programmed for the 5345A Counter must be of sufficient duration to give the desired resolution. Since the worst case resolution of the counter is 1 part in 10^8 per second of gate time, a 100 msec gate time, for example, would allow the counter to resolve a 100 kHz input frequency to $\pm .01$ Hz. The supplied program instructs the 5345A to make measurements with a 100 msec gate time.
- Since the minimum step size possible with the DAC is 10 mV, the STEP SIZE entered into the program should be an integer multiple of 10 mV so as to avoid errors caused by rounding.
- The accuracy of the 59303 DAC is specified as $\pm .1\%$ FS over the temperature range of 0° to 55°C . Typically, however, under room temperature conditions, the accuracy is $\pm .02\%$ FS. For those cases where DAC error is significant, the error may be essentially eliminated by using the bus compatible HP 3490A Multimeter to measure the DAC output and input this to the calculator for use in computations. Of course, the program would require modifications to enable the calculator to control the multimeter.
- The maximum allowable number of steps (i.e., $V_{MAX} - V_{MIN} / \text{STEP SIZE}$) is 300, and is limited by the storage capacity of the 9820 calculator.

Program Flow Diagram

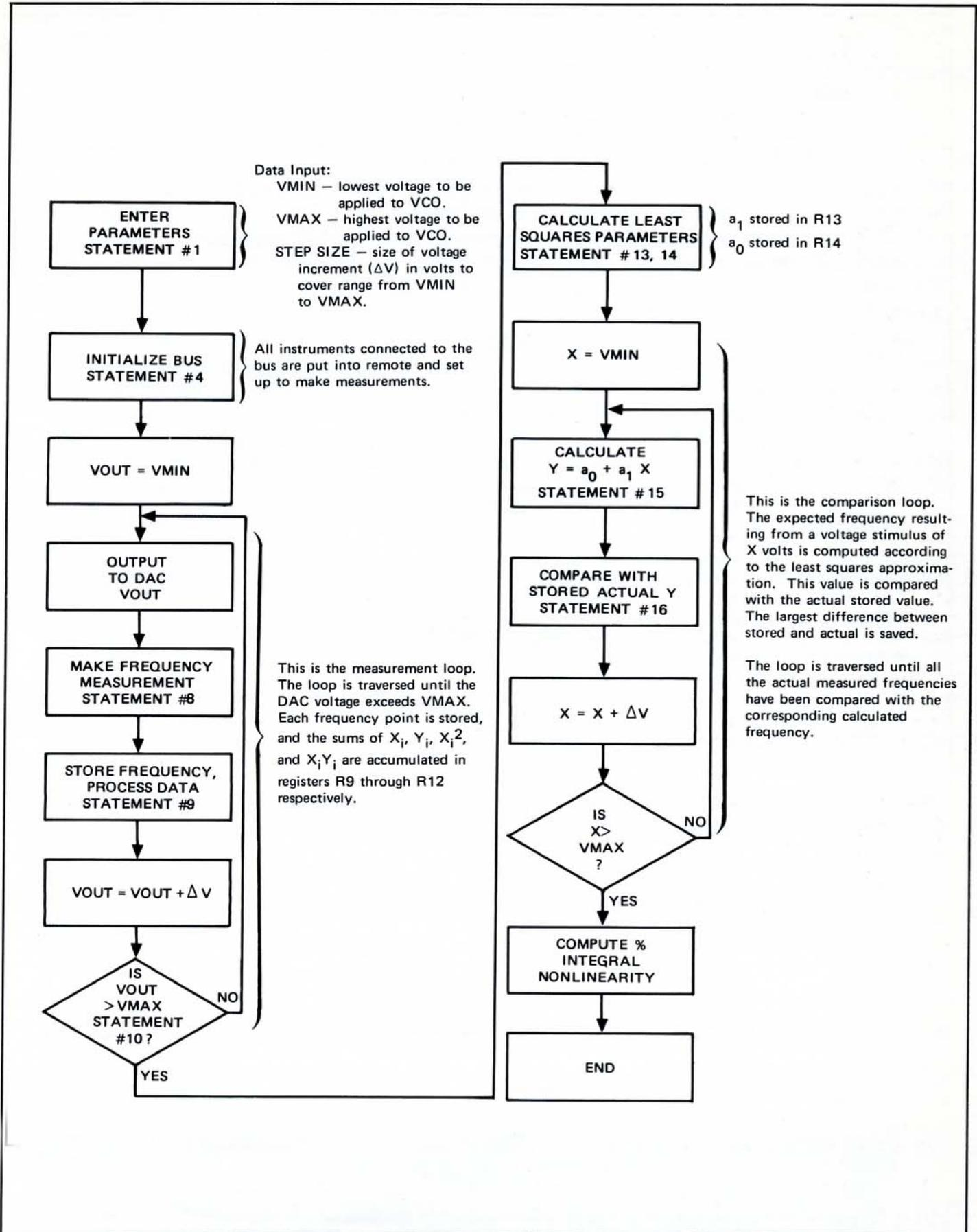

Program Listing

```

0:      DSP "INT. NONLIN
      .";DSP ;DSP ;
      DSP ;DSP +
1:      ENT "VMIN",R0;
      ENT "VMAX",R1;
      ENT "STEP SIZE";
      AF
2:      (R1-R0)/20+C;
      INT ((R1-R0)/A)+
      R2+
3:      R0+B+
4:      CMD "U?*", "I2E9:
      8I1G?";DSP ;CMD
      "J?","","U?=","E
      0"+
5:      0+R9+R10+R11+R12
      ;20+R8+
6:      "LOOP";CMD "U?<"
      ;FMT FXD *.0;
      WRT 13,100*B+
7:      CMD "U?0";FMT
      FXD *.2;WRT 13,B
      +
8:      CMD "U?*", "J1","
      J?35";FMT *;RED
      13,R6+
9:      R6+RR8;R9+B+R9;R
      10+R6+R10;R11+B*
      B+R11;R12+R6*B+R
      12+
      10:
      B+A+B;R8+1+R8;
      IF B>R1;GTO +2+
      11:
      GTO "LOOP";IF
      FLG 0;STP ;CFG 0
      +
      12:
      "INT";R0+B;20+R8
      ;0+R15+
      13:
      ((R2+1)*R12-R9*R
      10)/((R2+1)*R11-
      R9*R9)+R13+
      14:
      (R10-R13*R9)/(R2
      +1)+R14+
      15:
      "LOP1";R13*B+R14
      +Y+
      16:
      IF ABS (RR8-Y)>R
      15;ABS (RR8-Y)+R
      15+
      17:
      B+A+B;R8+1+R8;
      IF B>R1;GTO +2+
      18:
      GTO "LOP1"+
      19:
      FLT 6;PRT "Y=MX+
      B";PRT "M= (HZ/
      V)",R13,"B= (HZ
      )",R14+
      20:
      PRT "%INT. NONLI
      N =",R15/Y*100;
      SPC 8+
      21:
      DSP "FINISHED";
      GTO 0;STP +
      22:
      END +
      R334

```