

KEITHLEY

Model 7706 Multiplexer Card Packing List

PA-719 Rev. B / 2-00

A GREATER MEASURE OF CONFIDENCE

Introduction

This packing sheet contains information specific to the Model 7706 module. If you have any questions after reviewing this information, please contact your local Keithley representative or call one of our Applications Engineers at 1-800-348-3735 (U.S. and Canada only). This document is arranged as follows:

Description	Page
Connection	
Card configuration—schematic	2
Card configuration—connections	4
Wiring procedure	5
Typical connections (channels 1–20).....	7
Digital outputs (channels 21–22).....	9
Analog outputs (channels 23–24)	15
Totalizer	18
Totalizer channel monitor scan example.....	22
Specifications	24
Connection log	24
Front panel operation	
Card specific menu.....	26
Bus commands	
Sending channel numbers	27
OUTPut Subsystem.....	28
SENSe[1] Subsystem.....	29
Unsupported SCPI commands	30
Verification	
Analog outputs.....	30
Totalizer	32
Calibration	
Recommended test equipment	34
Extender board connections.....	34
Front panel Model 7706 temperature calibration.....	34
Remote Model 7706 temperature calibration	35
Front panel Model 7706 analog output (DAC) calibration.....	35
Remote Model 7706 analog output (DAC) calibration.....	36
Calibration commands	36
Remote error reporting	42
Detecting calibration step completion.....	44
Replaceable parts	45
Specifications	50

Connection

The Model 7706 is a 20-channel differential multiplexer card with the following features:

- 20 channels of analog input with 300V, 1A capacity; 60W, 125VA maximum
- 16 channels of digital output for output control
- One event counter/Totalizer
- Two analog outputs ($\pm 12V @ 5mA$ with 16-bit programmability)
- 2-wire or 4-wire Ω measurement (automatically pairs switches for four wire measurements — $n + 10$)
- Temperature applications (RTD, thermistor, thermocouple)
- Built-in automatic cold junction reference (CJC)
- Screw terminal connections
- Designed specifically for use with Keithley's Model 2700 Multimeter/Data Acquisition System

Card configuration—schematic

Figure 1 shows a simplified schematic diagram of the Model 7706 module. As shown, the Model 7706 has channels that are grouped into two banks of ten channels (twenty channels total). Backplane isolation is provided for each bank. Each bank also includes separate cold junction reference points. The first bank contains channels 1 through 10 while the second bank contains channels 11 through 20. Each channel of the 20-channel multiplexer card is wired with separate inputs for HI/LO providing fully isolated inputs.

NOTE

Although the Model 7706 relays are the latching type (relays hold their state even after power has been removed), all relay states are set to open a few seconds after either a power cycle or an *RST command is issued.

Connections to DMM functions are provided through the card backplane connector for the following:

- INPUT connections
- SENSE (Ω 4-Wire) connections

Channels 21–22 (digital output), 23–24 (analog output), and 25 (Totalizer) are controlled either over the bus or from the front panel. The grounds for these channels are non-isolated. Detailed information on each channel is contained later in this section.

Channel 26 (2W/4W Configuration), Channel 27 (Sense Isolation), and Channel 28 (Input Isolation) are normally automatically configured by the 2700. However, by using the :ROUT:MULT: commands (refer to Section 2 of the 2700 User's Manual), they can be manually configured.

Figure 1
Simplified schematic for Model 7706

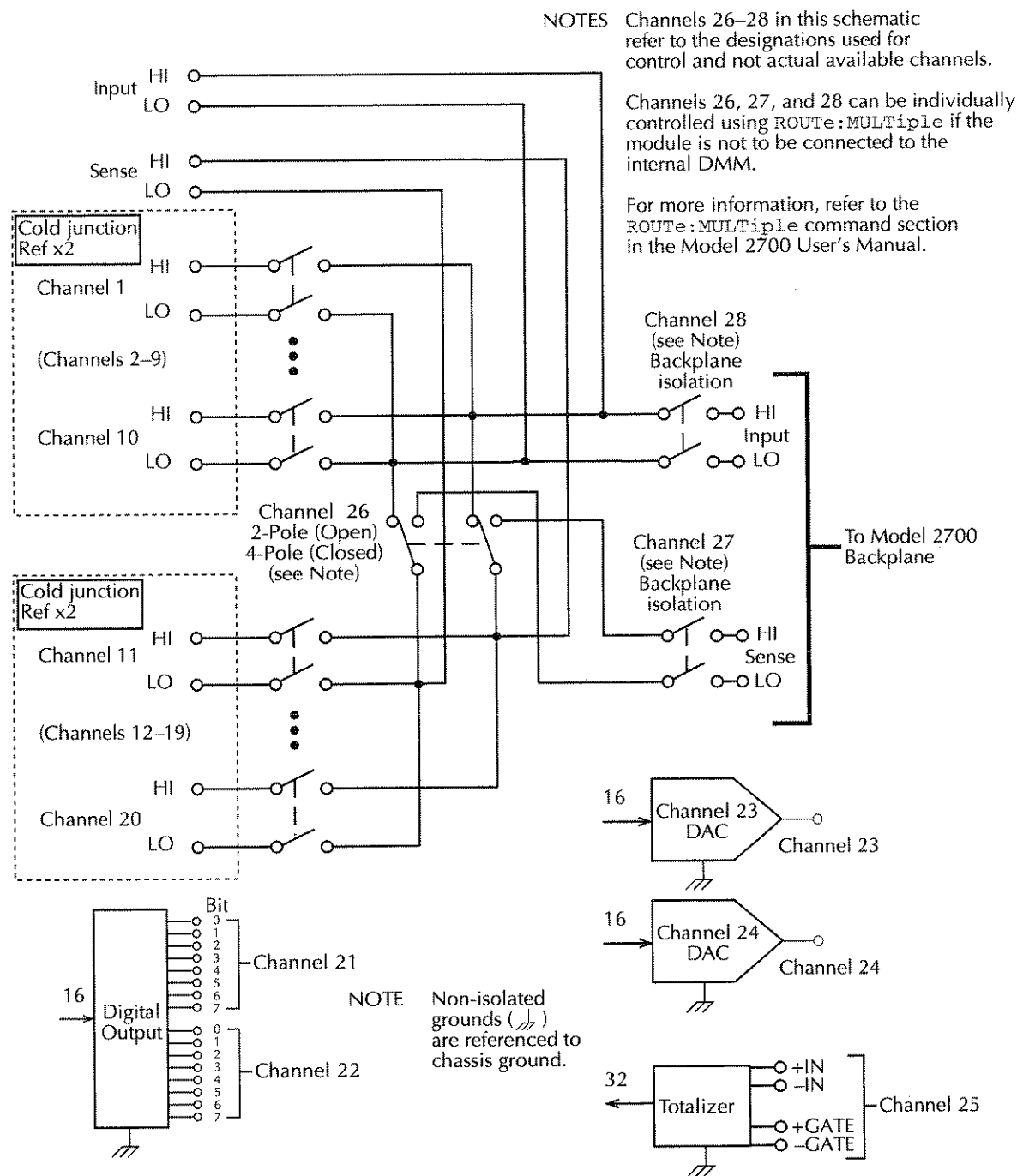

NOTES

Connect 4-wire sense leads using channels 11–20.

To disconnect channels 11–20 from channels 1–10, send:
:ROUTE:MULT:CLOS (@126) (note opposite logic)

When automatically configured for 4-wire measurements (including 4-wire Ω , RTD temperature, Ratio, and Channel average) the channels are paired as follows:

CH1 and CH11	CH6 and CH16
CH2 and CH12	CH7 and CH17
CH3 and CH13	CH8 and CH18
CH4 and CH14	CH9 and CH19
CH5 and CH15	CH10 and CH20

Card configuration—connections

WARNING

The information in this section is intended for qualified service personnel. Do not attempt to perform this procedure unless qualified to do so.

Figure 2 shows how to access the screw terminals on the Model 7706. Channel designations for the screw terminals are contained in Figure 3.

Figure 2
Screw terminal access

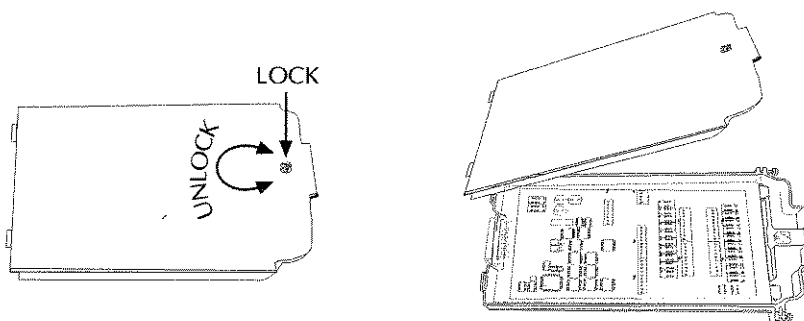

WARNING

Do not exceed the maximum specifications for the Model 7706 module. Refer to the end of this packing list for specifications.

Figure 3
Model 7706 screw terminal channel designations

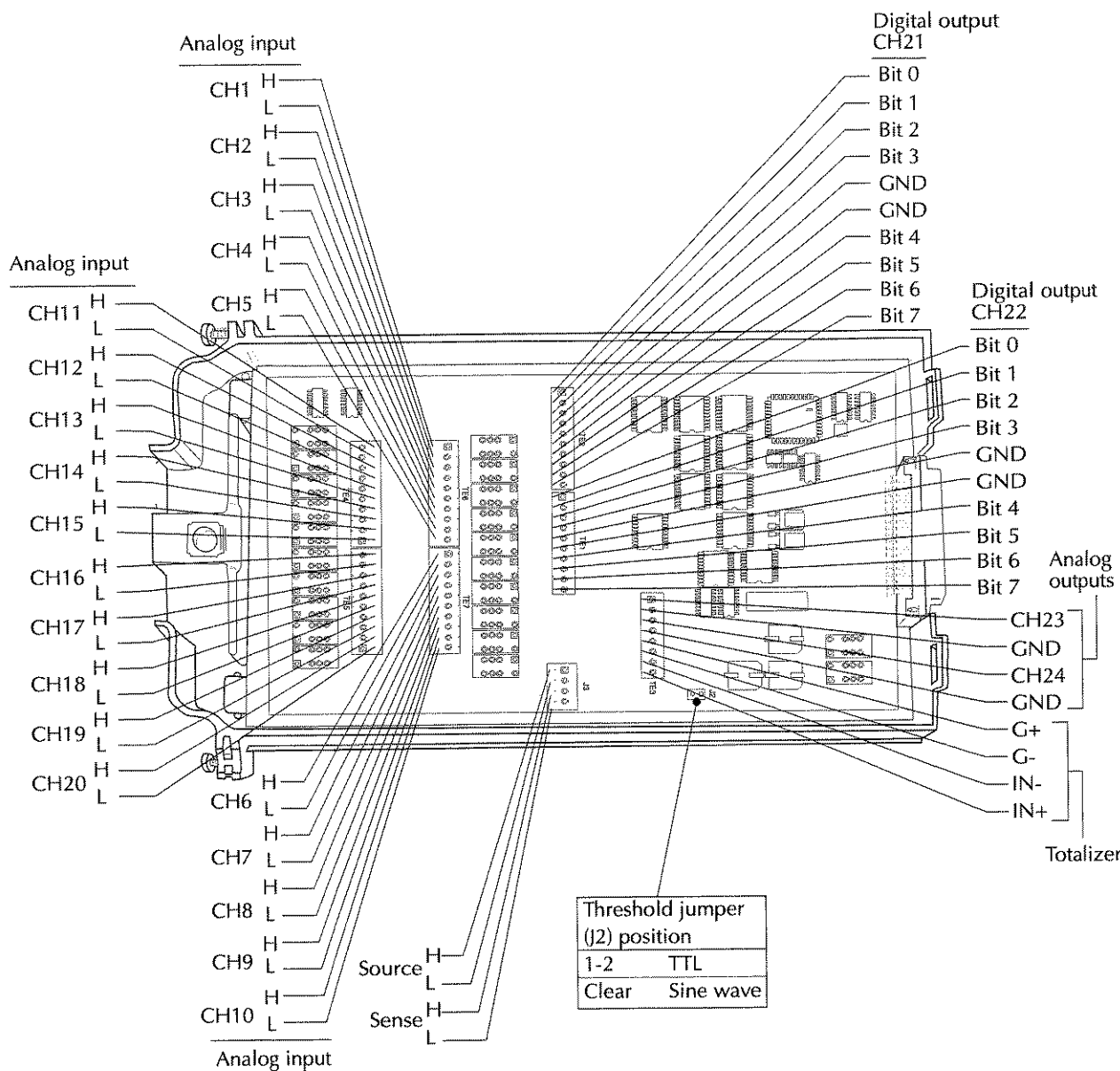

Wiring procedure

WARNING

The information in this section is intended for qualified service personnel. Do not attempt to perform this procedure unless qualified to do so.

Use the following procedure to wire the Model 7706 module. Make all connections using correct wire size (up to 22 AWG). Also, make sure to add supplementary insulation around the harness for voltages above 42V peak (see Figure 4).

WARNING

All wiring must be rated for the maximum voltage in the system. For example, if 1000V is applied to the front terminals of the Model 2700, the plug-in module wiring must be rated for 1000V.

1. Make sure all power is discharged from the Model 7706 module.
2. Access the screw terminals (see Figure 2).
3. Using a small flat-blade screwdriver, loosen terminal screws and install wires as desired. Figure 4 shows connections to all channels).
4. Route wire along wire-path and secure with cable ties as shown (see Figure 4).
5. Fill in a copy of the connection log (Table 1) and affix it to the module cover.
6. Close and lock cover.

WARNING

The Model 7706 module provides connections for both high voltage analog measurements as well as digital earth based circuits. Make sure to install and maintain double insulation between the analog and digital circuit wiring using supplementary insulation as required (see Figure 4).

Figure 4
Wire dressing—fully wired module

Note Secure wiring to 7706 by using cable ties through cable tie holes.

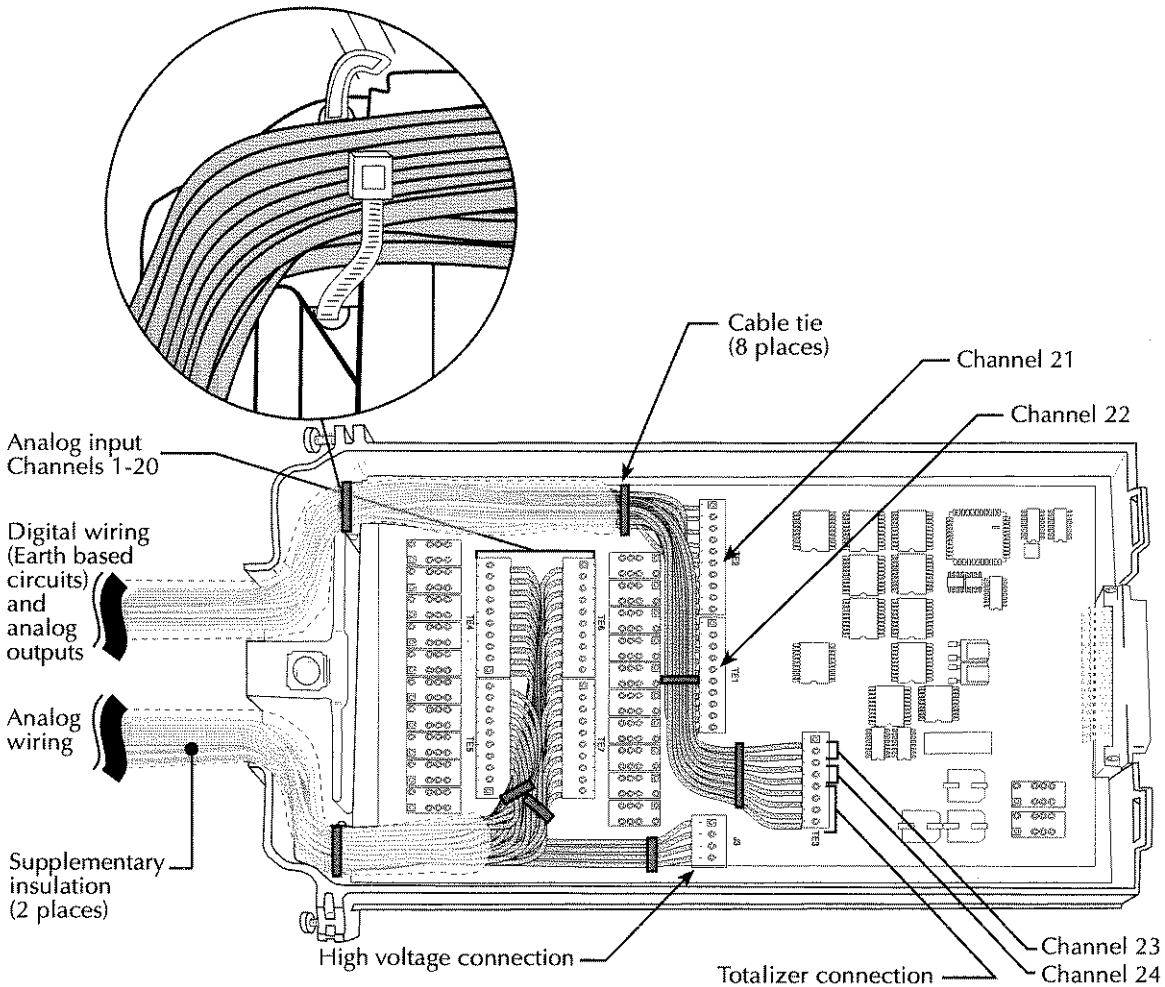

Typical connections (channels 1–20)

The following examples show typical wiring connections for the following types of measurements:

- Thermocouple connections, see Figure 5
- Ω 2-Wire and thermistor connections, see Figure 6
- Ω 4-Wire and RTD connections, see Figure 7
- Voltage (AC or DC), see Figure 8

Figure 5
Thermocouple connections

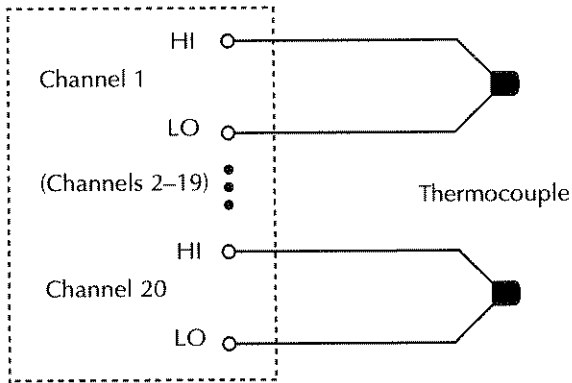

Figure 6
 Ω 2-Wire and thermistor connections

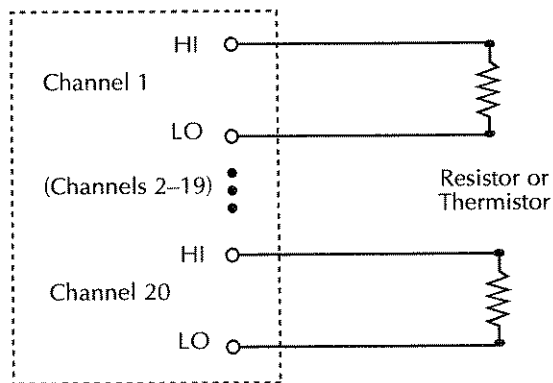

Figure 7
Ω4-Wire and RTD connections

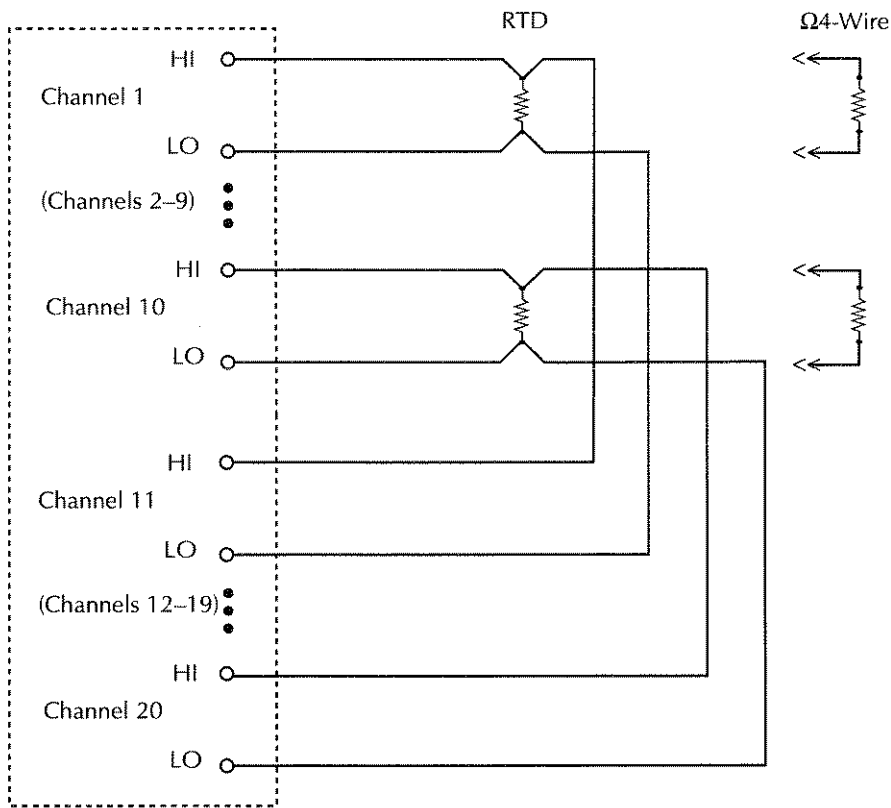
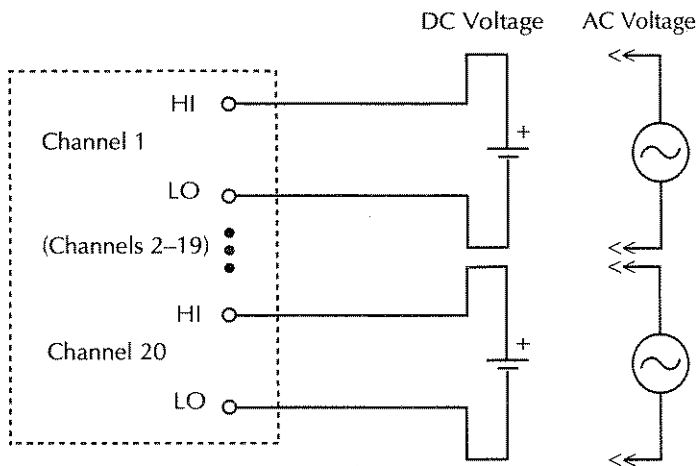

Figure 8
Voltage connections (DC or AC)



Digital outputs (channels 21–22)

Use the Model 7706 digital outputs to control indicators, fixtures, switches, solenoids, loads, relays, etc. Figure 9 shows a simplified schematic of the digital output.

Figure 9
Simplified schematic of digital output

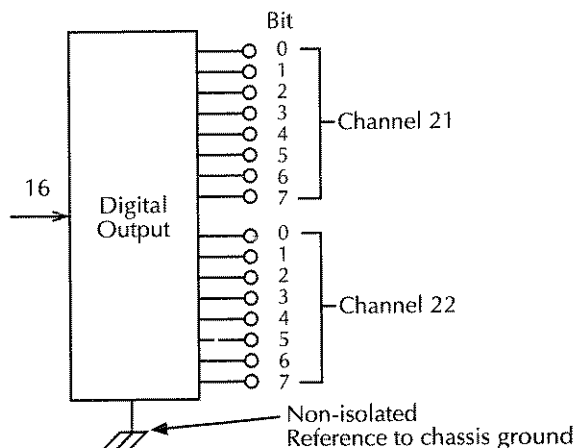

Setting the digital output in 8-bit (byte)

To set the digital output, send the decimal equivalent of the binary pattern desired. Keep in mind that on each port, bit 7 is the most significant bit (MSB) and bit 0 is the least significant bit (LSB). This makes the pin 1 screw terminal of each digital port (TE2 and TE1) the LSB, and pin 10 the MSB.

NOTES

TE2 is Channel 21 and TE1 is Channel 22.

Pins 5 and 6 on each digital port are ground.

To find the decimal equivalent of the binary pattern, first determine the pattern mapped to the screw terminals on the desired digital output (refer to the example contained in Figure 10). Setting a bit to a logic '1' effectively sets the screw terminal to +5V, while setting it to a logic '0' sets the screw terminal to 0V. Then, for each screw terminal (or bit position), multiply the binary value (either a 1 or a 0) by the decimal weight (see Figure 10). The sum of the products is the decimal equivalent value of the binary pattern. This decimal value can be either sent over the bus (as in the example) or by using the front panel of the Model 2700. To send it over the front panel: under the SHIFT->CARD menu, key in the decimal value (138) for the menu item "DIGOUT1: XXX". Refer to Figure 11 for a sample on Channel 22.

Figure 10
Sample digital output for Channel 21

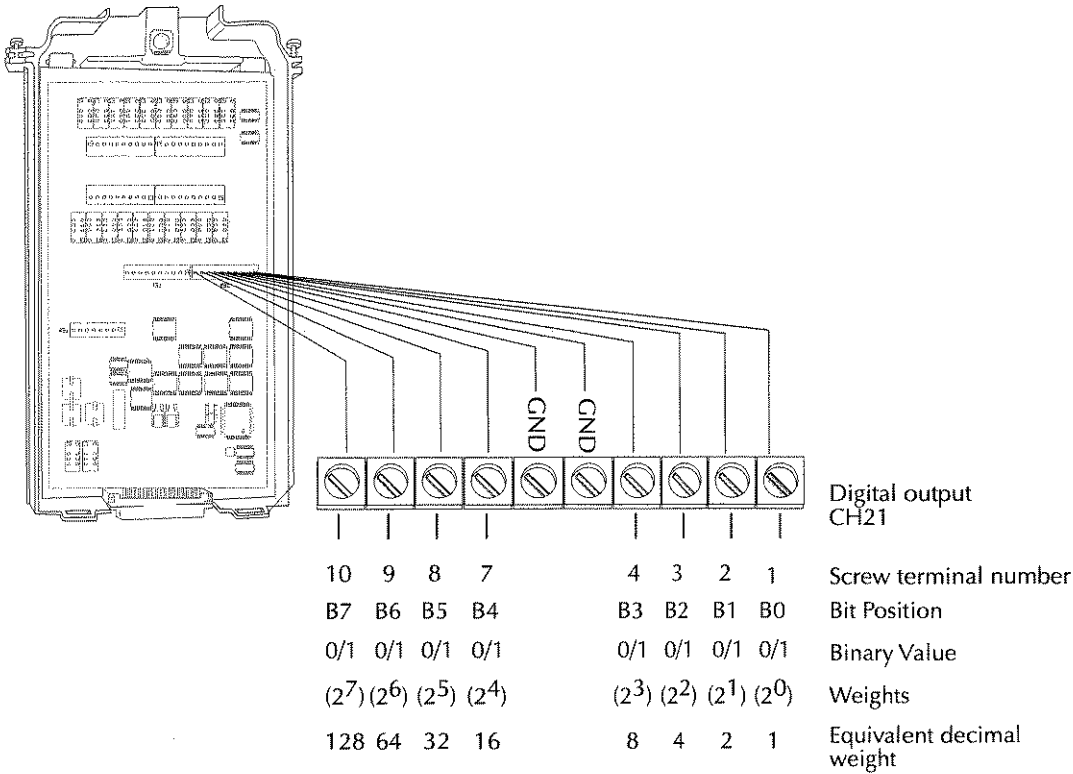

Example:

Channel 21	1	0	0	0	1	0	1	0	
	10	9	8	7	4	3	2	1	
Multiply the binary values	1	0	0	0	1	0	1	0	Binary Value
by the decimal weight	128	64	32	16	8	4	2	1	Decimal weight
Add the products together	128 + 0 + 0 + 0				+	8 + 0 + 2 + 0			= 138 (this is the NRf value in the command)

Therefore, the command to send is:
OUTP: DIG: BYTE 138, (@121)

- Channel 21 of the Model 7706 in slot 1
- NRf value of 138 (specifies which terminals are 1 / 0)
- 8 bit
- Digital
- Output

Figure 11
Sample digital output for Channel 22

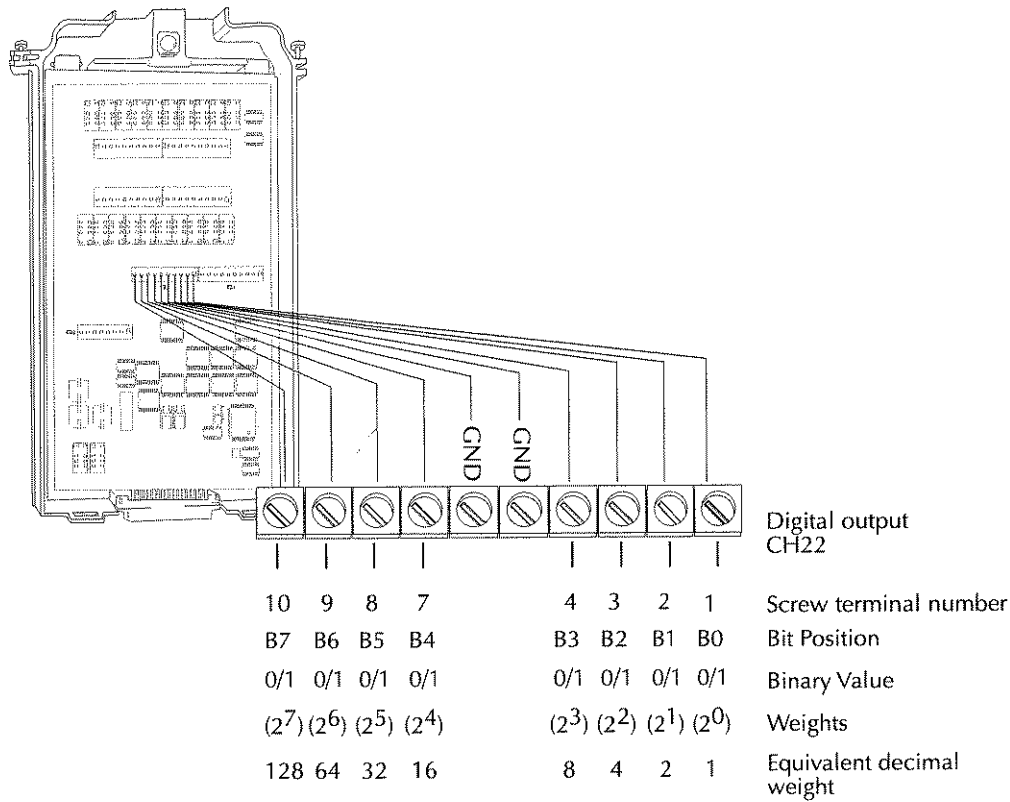

Example:

Channel 22	1	0	0	0	1	0	0	1	
	10	9	8	7	4	3	2	1	
Multiply the binary values	1	0	0	0	1	0	0	1	Binary Value
by the decimal weight	128	64	32	16	8	4	2	1	Decimal weight
Add the products together	128 + 0 + 0 + 0				+	8 + 0 + 0 + 1			= 137 (this is the NRf value in the command)

Therefore, the command to send is:
OUTP:DIG:BYTE 137, (@122)

- Channel 22 of the Model 7706 in slot 1
- NRf value of 137 (specifies which terminals are 1 / 0)
- 8 bit
- Digital
- Output

Setting the digital outputs in 16-bit (word)

NOTE

Setting the digital output in 16-bit (word) can be accomplished only over the bus (no front panel operation).

To set the digital outputs in 16-bit, send the decimal equivalent of the binary pattern desired (similar to 8-bit). The binary pattern will be twice as long as the 8-bit pattern (requiring both digital output ports). Keep in mind that bit 15 is the most significant bit (MSB) and bit 0 is the least significant bit (LSB). This makes the pin 1 screw terminal of Channel 21 (TE2) the LSB and the pin 10 screw terminal of Channel 22 (TE1) the MSB.

To find the decimal equivalent of the binary pattern, first determine the pattern mapped to the screw terminals on the desired digital output (refer to the example contained in Figure 12). Setting a bit to a logic '1' effectively sets the screw terminal to +5V while setting it to a logic '0' sets the screw terminal to 0V. Then, for each screw terminal (or bit position), multiply the binary value (either a 1 or a 0) by the decimal weight (see Figure 12). The sum of the products is the decimal equivalent value of the binary pattern. This decimal value can be sent over the bus as in the example.

The digital output allows the use of an external power supply up to 42V. Refer to Figure 13.

Inductive loads

Model 7706 operation is specified for resistive loads. Reactive (inductive) loads require voltage clamping. Before using inductive loads, take adequate circuit protection measures (refer to the appropriate appendices of the Model 2700 User's Manual).

Figure 12
Sample sending a digital output word (16-bit)

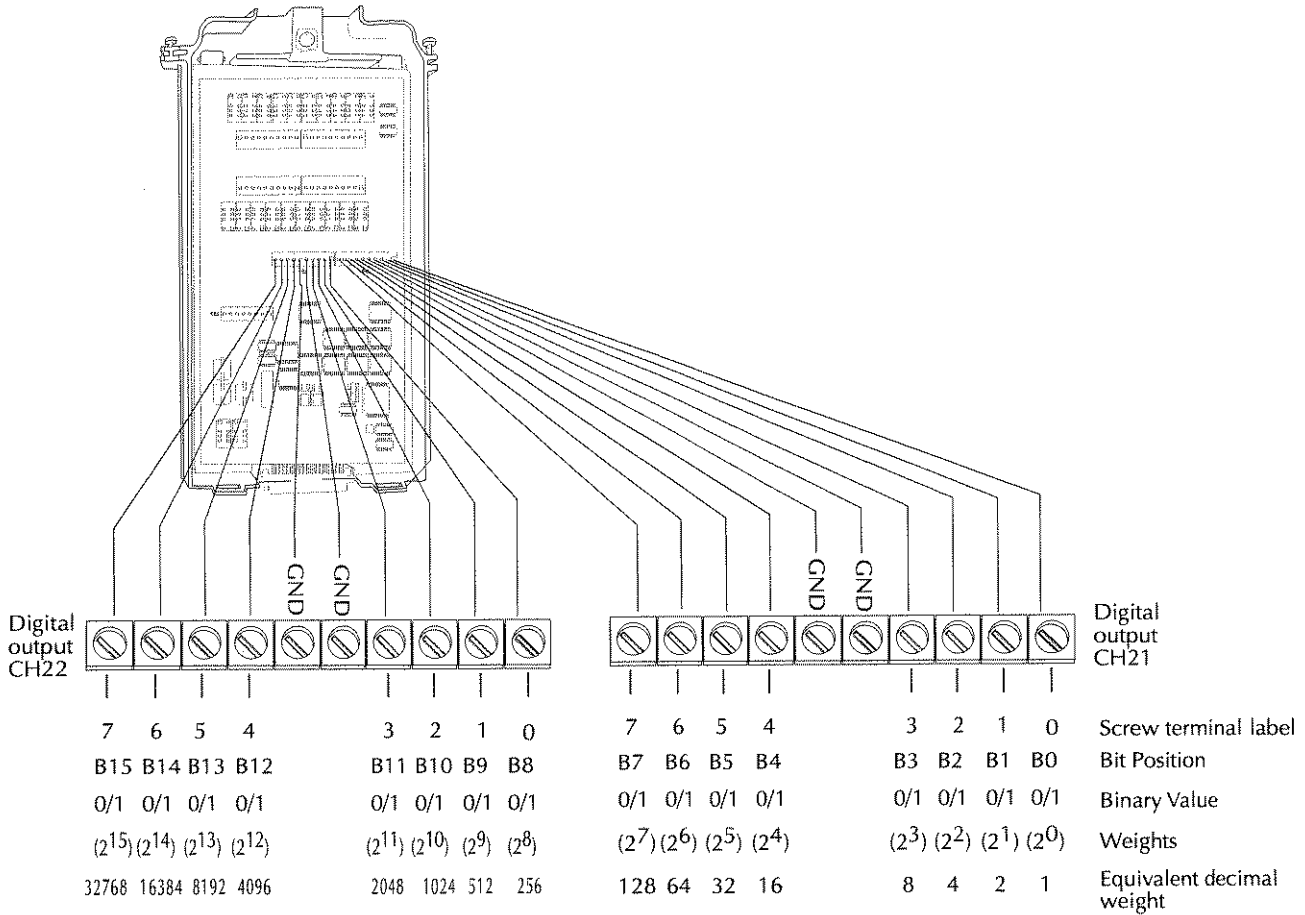

1	1	0	0	0	0	0	0	1	0	0	0	1	0	0	0								
7	6	5	4	3	2	1	0	7	6	5	4	3	2	1	0								
Binary Value								Binary Value															
1	1	0	0	0	0	0	0	1	0	0	0	1	0	0	0								
Decimal weight								Decimal weight															
32768	16384	8192	4096	2048	1024	512	256	128	64	32	16	8	4	2	1								
32768+16384+0+0								128+0+0+0								8+0+0+0 = 49288 (this is the NRf value in the command)							

Therefore, the command to send is:
OUTP: DIG: WORD 49288, (@121)

- Channel 21 of the Model 7706 in slot 1 (this command can only be sent to Channel 21)
- NRf value of 49288 (specifies which terminals are 1 / 0)
- 16 bit
- Digital
- Output

Figure 13
Typical digital output with external power supply

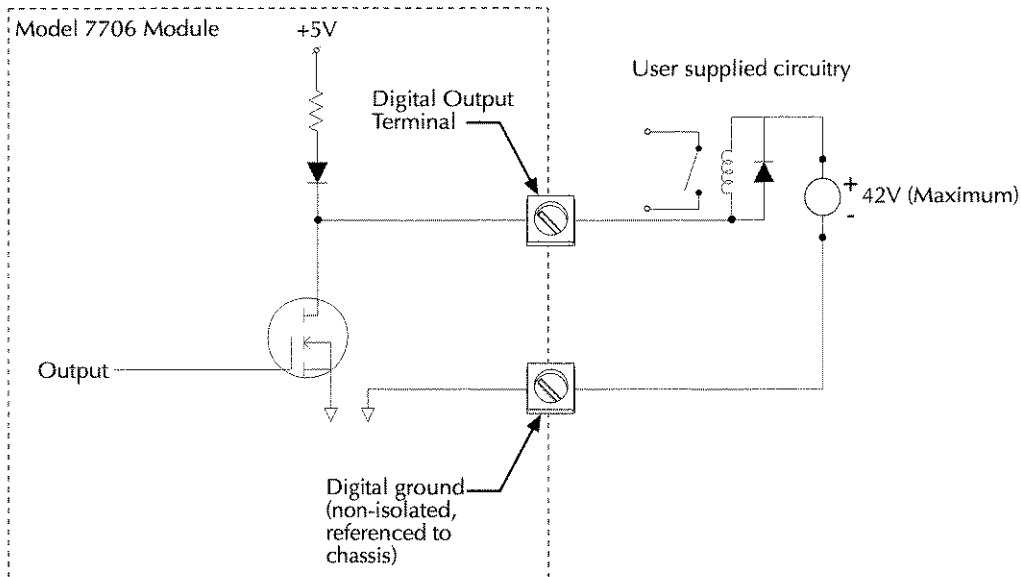
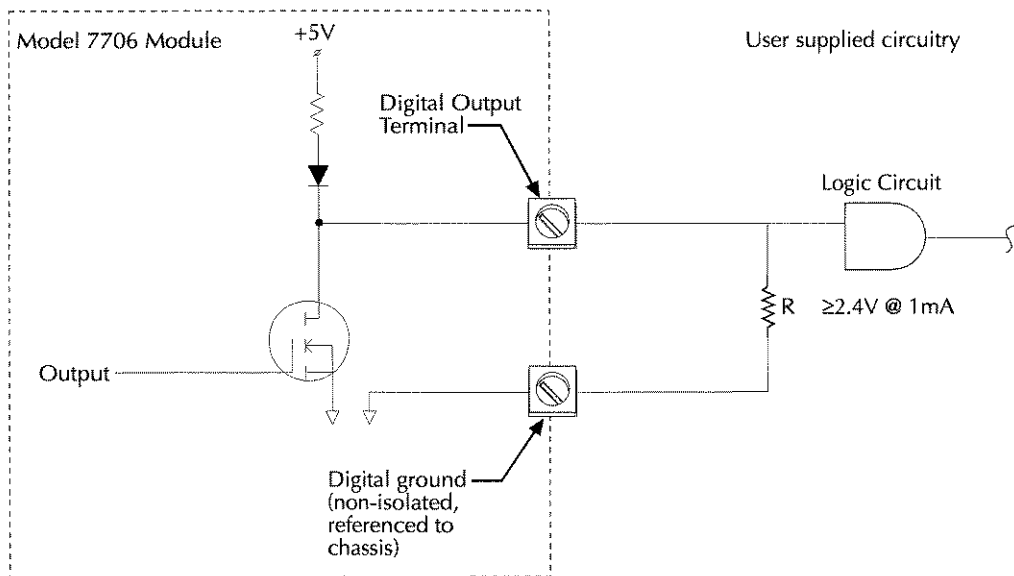

Figure 14
Typical digital output (no external power supply)



Analog outputs (channels 23–24)

CAUTION

Analog output current limit: 5mA (maximum).

The Model 7706 contains two DAC (Digital to Analog Converters). Use these analog outputs for tasks such as applying a voltage bias to DUTs or analog control. The two analog outputs of the Model 7706 are capable of providing voltages in the range of $\pm 12\text{V}$. The analog outputs can be set from the front panel or over the bus. Figure 15 shows a simplified schematic of the analog outputs.

Figure 15

Analog output

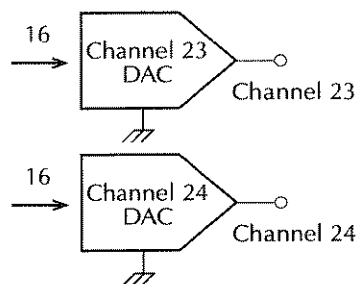

In the following examples, the Model 7706 module is in slot one of the Model 2700.

Sample 1: Set analog output 1 (channel 23) to 10.0V

To set analog output 1 using the front panel: under the SHIFT->CARD menu, key in the decimal value (for this example, 10.0) for the menu item “AOUT1: +XX.XX”, and press enter. To set Channel 23 (analog output 1) over the bus, send the following command:

```
OUTP:VOLT 10.0, (@123)
```

NOTES

Refer to “Front panel operation” for more information on menus and key location.

Voltage may be set in 1mV steps (values are rounded to the nearest millivolt).

Sample 2: Set analog output 2 (channel 24) to -5.5V

To set analog output 2 using the front panel: under the SHIFT->CARD menu, key in the decimal value (for this example, -5.5) for the menu item "AOUT2: +XX.XX", and press enter. To set Channel 24 (analog output 2) over the bus, send the following command:

```
OUTP:VOLT -5.5, (@124)
```

Note that each output is referenced to the chassis. Each output can not "float" from each other. To operate with the analog output in specification as a calibrated voltage source, the minimum resistance load is $2.2\text{k}\Omega$ (refer to Figure 16).

Figure 16

Sample analog connection schematic

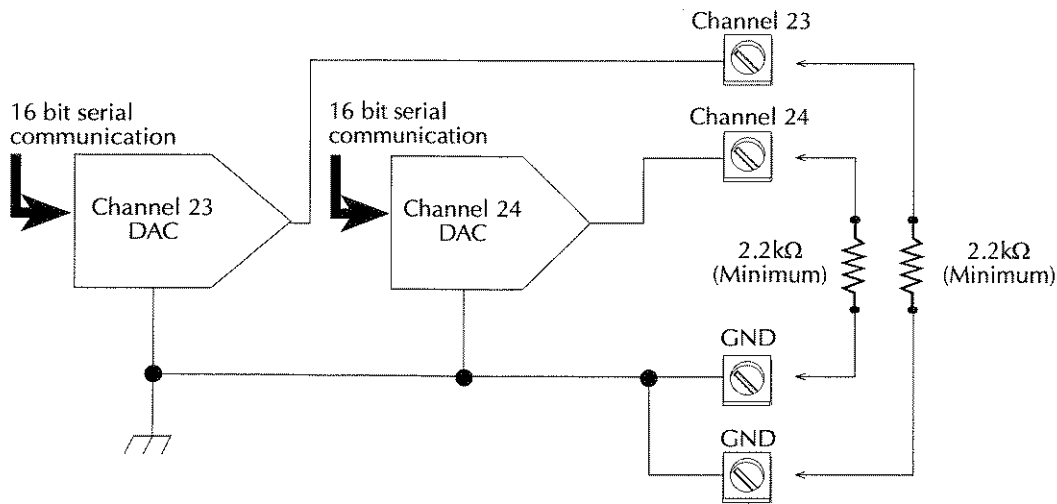

Loading effects

Loading of the voltage source becomes a consideration for low resistance loads. As the source resistance increases, the error caused by loading increases. Figure 17 shows the method used to determine the percent error due to loading where:

V_S is the programmed analog output of the Model 7706

R_{Lead} is the total lead resistance of the wiring and connections

R_{Load} is the resistance of the user's circuit

V_M is the measured voltage

The voltage actually measured by the meter is attenuated by the voltage divider action of R_S and R_L , and it can be calculated as follows:

$$V_M = \frac{V_S R_{Load}}{R_{Load} + R_{Lead}}$$

This relationship can be modified to directly compute for percent error:

$$\text{Percent Error} = \frac{R_{Load}}{R_{Load} + R_{Lead}} \times 100$$

Using the above equation, to keep loading error within 0.1%, the resistance of the Model 7706 system must be at least 1/999th the value of load resistance.

Figure 17

Loading effects

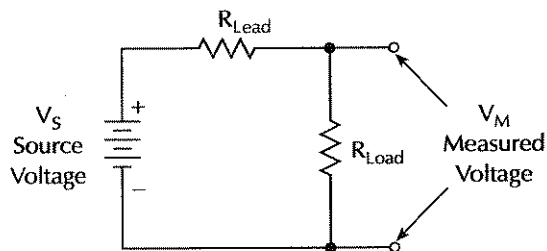

DAC output errors

The DAC output is most accurate when the Model 7706 is operated in stable temperature conditions that are as close as possible to the environmental conditions used for calibration. Offset voltage drift over temperature is 1mV/°C. Also, the offset voltage value may change when changing from slot 1 to slot 2.

Totalizer

Use the Totalizer to count more than 4 billion on/off events (contact closures, revolutions, power cycles, etc.). The Totalizer can be accessed from the front panel or over the bus. Figure 18 shows a simplified schematic of the Totalizer connected to a function generator.

NOTE

The Totalizer can count exactly up to 4,294,967,295 events ($2^{32}-1$). The count resets (sets its value to 0) when it reaches 2^{32} .

Figure 18
Totalizer

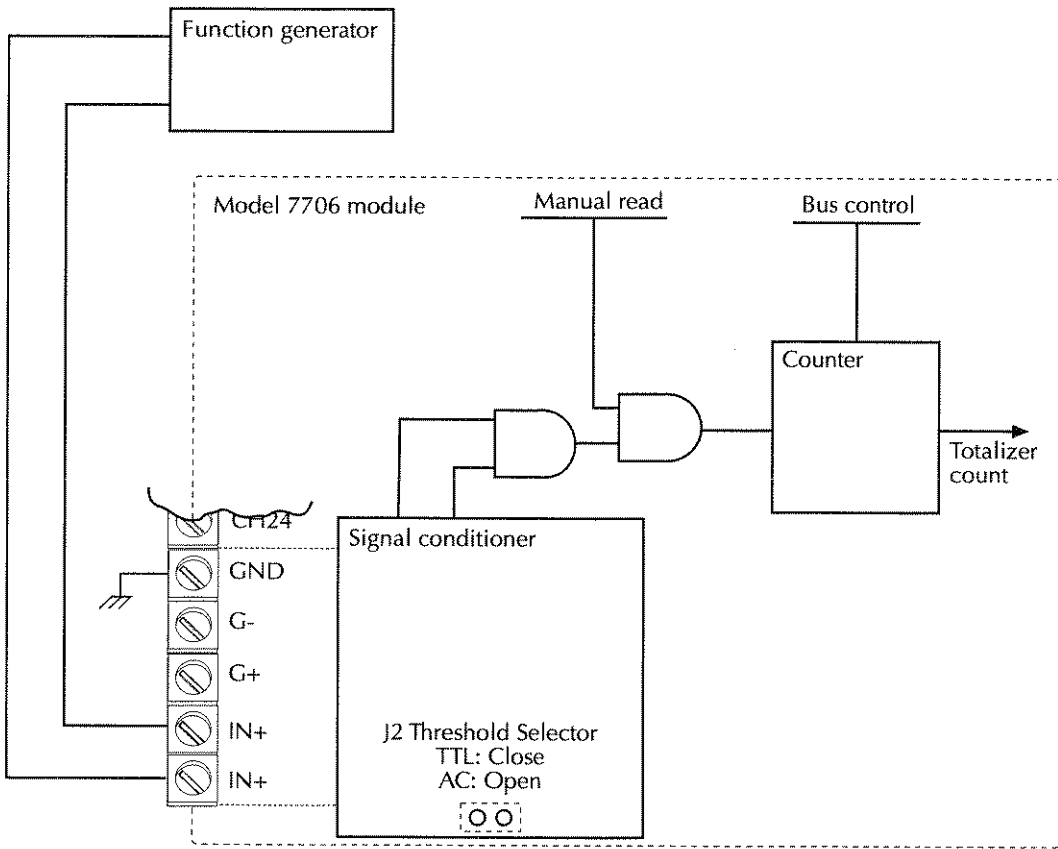

Threshold detection

The Totalizer can count events at a rate of up to 100kHz. The count can be initiated manually or by configuring a scan. When counting, the Totalizer can:

- Reset to zero every time it is read.
- Count on the rising or falling edge of the input signal.
- Count AC or TTL signals.
- Be governed by a gate signal.

Either through a menu (Figure 23) or over the bus (Table 5), the Totalizer can be configured to read (“READ”), or read and reset (“RRES”). It can also be configured to which edge of the signal is read (rising or falling).

The type of threshold detected by the Totalizer is set by the position of jumper J2 (see Figure 3). Factory default setting for this jumper is closed (TTL). The TTL wave as well as the AC type wave form are shown in Figure 19.

Figure 19

AC and TTL waveforms

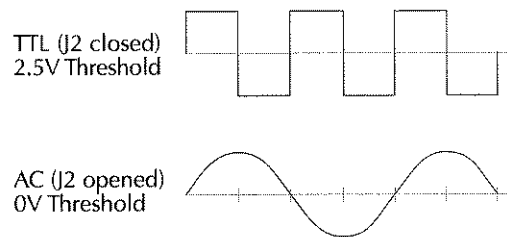

NOTES

The Totalizer counts when both terminals are either enabled or open.

Threshold levels cannot be programmed or set.

Gating provides specific control over when the Totalizer readings are taken. A gate always is interpreted if no gating signal is present. To control counting through the G+ screw terminal, send a TTL high signal to enable counting and a TTL low signal to disable counting. To control counting through the G- screw terminal, send a TTL low signal to enable counting and a TTL high signal to disable counting. The Totalizer can be controlled from the G+ screw terminal, the G- screw terminal, or both (both G+ and G- screw terminals have to be enabled to count). Samples of Totalizer input with gating are contained in Figure 20.

Figure 20
Sample totalizer input with gating

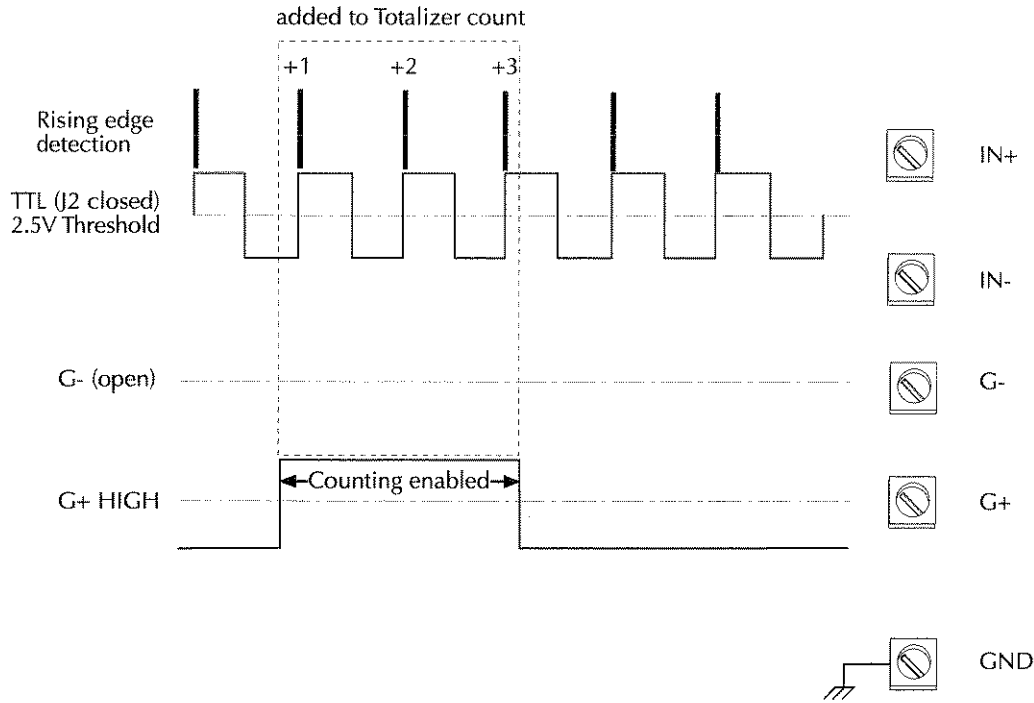

Viewing Totalizer count

View the Totalizer count by using the CLOSE key and entering the Totalizer channel number (front panel). This opens all relays, switches the Model 2700 function to Totalizer (“TOTALIZE”), and remembers the previous function. In this mode, the TOTALize:TYPE setting is ignored (effectively ‘READ’).

The front panel of Model 2700 is shown in Figure 21. When viewing the Totalizer count, the Model 2700 keys function as contained in the list keyed to Figure 21.

Figure 21
Model 2700 front panel key operation (Totalizer)

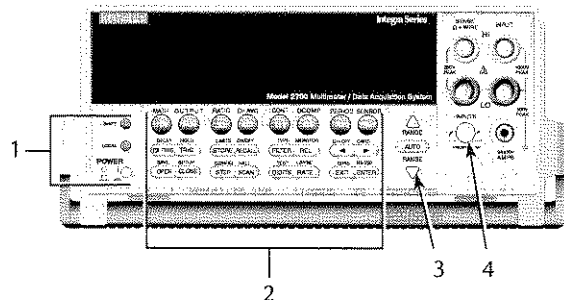

1 Special keys and power switch:

Normal operation.

2 Function and operation keys:

Top Row

Unshifted

DCV, ACV, DCI, ACI, Ω2, Ω4, FREQ, TEMP Blocked.

Shifted

RATIO,CH-AVG, CONT, OCOMP, PERIOD Blocked.

Middle Row

Unshifted

TRIG Triggers the unit to read the current Totalizer count.
 ◀ and ▶ Moves between Totalizer channels (if more than one Model 7706 installed).

STORE, RECALL, FILTER, REL Blocked.

Shifted

LIMITS Sets the High Limit count for the Totalizer.

ON/OFF Enables/disables limits.

MONITOR Sets unit to monitor Totalizer channel and turns monitor on. If monitor is already on, it will be turned off.

CARD Enters the card specific menu.

DELAY, HOLD Normal Operation.

TYPE, CH-OFF Blocked.

Bottom Row

Unshifted

OPEN, CLOSE Normal operation.

EXIT Clears the Totalizer count to zero.

STEP, SCAN, DIGITS, RATE, ENTER Blocked.

Shifted

SAVE, SETUP, CONFIG, TEST, GPIB, RS-232 Normal operation.

HALT, LSYNC Blocked.

3 Range keys:

▲ and ▼ Normal operation.

AUTO Blocked.

4 INPUTs switch:

Normal operation—the position of this switch does not affect Totalizer operation.

Adding Totalizer to scan list (via front panel)

Toggle the state of the Totalizer channel in the scan list using the SHIFT->CH-OFF key. The TYPE and EDGE controls are set globally through the SHIFT->CARD menu key.

NOTE

Changing Totalizer settings (“READ” or “RRES”) must be done outside of the scanlist configuration.

Adding to scan list via GPIB

The ROUT:SCAN command is used to add Totalizer to the scan list. When a card that supports Totalizer is in the unit, the Totalizer channel can only be used as a Totalizer. Whenever it is added to the list it will read the current count value. The TYPE and EDGE controls are set globally through the SENSE:TOTALize:EDGE and SENSE:TOTALize:TYPE commands.

Limits and analog trigger

The limit subsystem and analog scan triggering works the same for the TOTALize function as for any other Model 2700 function with the exception that only the UPPER limit is evaluated. The LOWER limit setting is ignored by the TOTALize function. The TOTALizer MUST be monitoring in order to initiate a scan based on a Totalizer limit. When a scan is initiated by a Totalizer count, and the Totalizer type is set to 'READ', the limit that initiated the scan is removed from the ROUTe:SCAN:TSource list so that the Model 2700 only runs through the scan list once. Otherwise, it would keep scanning since the TOTALizer count would remain above the upper limit until reset.

Totalizer channel monitor scan example

For this example, Channel 25 of the Model 7706 is used to monitor the Totalizer with the Model 7706 inserted into slot 1 of the Model 2700. This is an example of a four channel scan with Channels 101–103 measuring DC voltage while, as previously mentioned, Channel 125 monitors the Totalizer. As programmed, when the Totalizer reaches 100,000 counts, the scan is initiated.

Operation

A simplified model of scan operation is contained in Figure 22. The procedure for front panel operation and equivalent programming commands for this simplified model is contained in Table 1. For this example, there are two modes of operation: monitor and scan (see Figure 22). While in monitor mode, continuous Totalizer measurements are performed. The instrument remains in the monitor mode until it reaches the high limit (in this example, the high limit is set to 100,000 counts). When this limit is reached, the instrument changes over to scan mode (see Figure 22). The instrument is configured to scan four channels: three DCV readings and the Totalizer channel (the buffer stores all four readings). After the fourth channel is measured, operation turns again to the monitor mode to again measure Totalizer.

NOTE

When scan is initiated by a TOTALizer count with the type set to READ, the limit that initiated the scan is removed from the ROUTe:SCAN:TSource list. This makes the unit run the scan list once. Otherwise, scanning would continue until reset as long as the TOTALizer count remains above the upper limit. If the type is set to RRES when a scan is initiated and after the Totalizer channel is scanned, it is reset to zero (0). If the Totalizer again counts past the high limit set, the unit will run the scan list again, reset the count to zero, and so on.

Figure 22
Monitor scan example

Monitor Mode:

Close Monitor Channel (125)

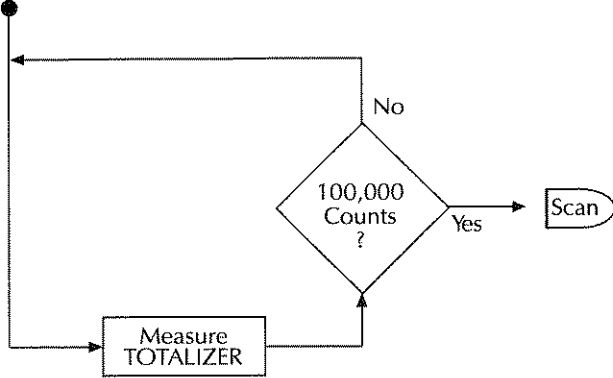

Scan Mode:

Close First Channel

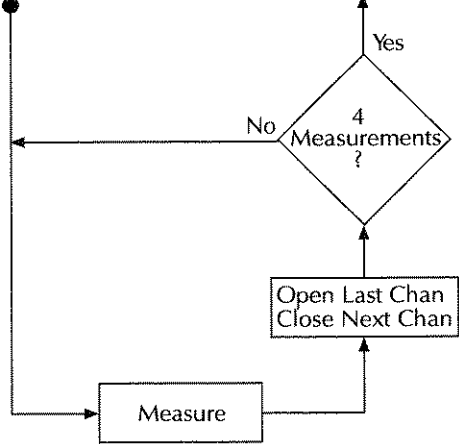

Table 1
Monitor scan example (front panel and remote steps)

Step	Front panel operation	Remote programming
1	Restore defaults: Restore defaults (SHIFT SETUP > RESTORE: FACT).	*RST
2	For front panel operation, proceed to step 3. For remote programming, clear buffer and disable buffer auto clear:	TRAC:CLE
3	Configure advanced scan (SHIFT CONFIG > ADVANCED):	
a	Channel 101, 102, and 103: Select DCV function. Select 10V range. Set filter count to 20 (SHIFT TYPE > 020 RDGS). Enable filter (FILTER).	FUNC 'VOLT', (@101:103) VOLT:RANG 10, (@101:103) VOLT:AVER:COUN 20, (@101:103) VOLT:AVER:STAT ON, (@101:103)
b	Channel 104: Disable (off) Channels 104-120 (SHIFT CH-OFF).	ROUT:SCAN (@101:103,125)
c	Channel 125: Enable Totalizer channel (SHIFT-CH OFF). Set and enable high limit 1: Set limit to 100000 (SHIFT LIMITS > HI1:+100.0000K). Set and enable high limit 2: Set limit to 1000000000 (SHIFT LIMITS > HI2:+1000000K). Enable (on) limit (SHIFT OFF/ON > LIMITS: ON).	CALC3:LIM1:UPP 1e5, (@125) CALC3:LIM1:STAT ON, (@125) ROUT:SCAN:TSO HLIM1
d	Disable immediate scan (IMM SCAN: N), and enable high limit 1 (HLIM1 SCAN:Y).	
e	Disable timer (TIMER? OFF).	
f	Set reading count to 4.	
4	For front panel operation, proceed to step 5. For remote programming, set the number of points in the monitor scan.	ROUT:MON:POIN 4
5	Select and enable monitor channel (SHIFT MONITOR > 125).	ROUT:MON (@125) ROUT:MON:STAT ON

Specifications

Full Model 7706 specifications are included in Appendix A of the Model 2700 User's Manual.

Connection log

Make a copy of Table 2 and affix it to the cover of the Model 7706. Use this to record connection information and channel descriptions as needed.

Table 2
Connection log Model 7706

Channel	Color	Description
INPUT	H	
	L	
SENSE	H	
	L	
CH1	H	
	L	
CH2	H	
	L	
CH3	H	
	L	
CH4	H	
	L	
CH5	H	
	L	
CH6	H	
	L	
CH7	H	
	L	
CH8	H	
	L	
CH9	H	
	L	
CH10	H	
	L	
CH11	H	
	L	
CH12	H	
	L	
CH13	H	
	L	
CH14	H	
	L	
CH15	H	
	L	
CH16	H	
	L	
CH17	H	
	L	
CH18	H	
	L	
CH19	H	
	L	
CH20	H	
	L	
CH21	B0 B1 B2 B3 B4 B5 B6 B7 GND	
CH22	B0 B1 B2 B3 B4 B5 B6 B7 GND	
CH23	H	
	GND	
CH24	H	
	GND	
CH25	IN+ IN- G+ G-	

Front panel operation

Card specific menu

To open the card specific menu, press SHIFT->CARD (CARD is over the RIGHT arrow key). This menu contains all card-specific functions from the front panel. For example, the analog outputs of a 7706 card would be configured from here. A sample of accessing the card specific functions is contained in Figure 23.

Figure 23
Menu tree — Accessing card specific functions

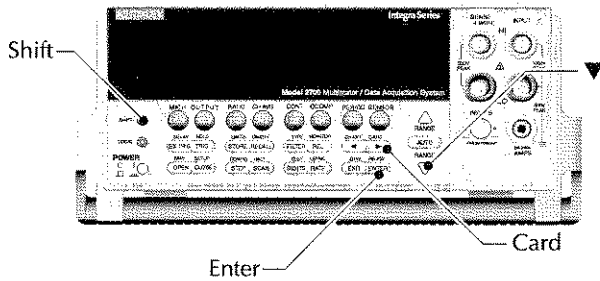

Sequence	Key	Display
1	SHIFT-CARD	SLOT1: 7706
2	ENTER	AOUT1: +00.000V
3	▼	AOUT2: +00.000V
4	▼	DIGOUT1: 255
5	▼	DIGOUT2: 255
6	▼	TOT TYPE: (READ RRES)
7	▼	TOT EDGE: (RISE FALL)
8	▼	SWREV: A01
		<i>Readings mode</i>
9	▼	SLOT2: 7702
10	ENTER	Resumes normal readings since the Model 7702 does not have card-specific features that need to be addressed in this menu.

Bus commands

When issuing commands over the bus, keep the following channel usage in mind:

Table 3

Channel description

Channels	Description
1-20	Voltage, resistance, temperature, frequency, period, etc., measurements
21-22	Eight-bit digital outputs
23-24	Sixteen-bit analog outputs
25	Totalizer
26	2/4 pole selection relay. Closing Channel 26 makes a 4-pole measurement
27	Sense terminals to backplane isolation
28	Input terminals to backplane isolation

Sending channel numbers

Express channel numbers as a three-digit number where the first digit is the slot number. For example, Channel 1 on slot 1 would be Channel 101, and Channel 5 on slot 2 would be 205. The hundreds digit is the slot number, and the remaining digits denote the channel number on the card (see "Channel list parameter" located at the bottom of Table 4).

OUTPut Subsystem

Commands to perform output operations are listed in Table 4. Details on these commands follow the table.

NOTE

The output subsystem is specific to the Model 7706 module. It is only available if a Model 7706 is installed.

Table 4
Output subsystem commands

Command	Description	Default
:OUTPut	Set the output of a 7706 channel.	
:VOLTage <nrf>, <clist>	Forces the analog output of the given analog channel[s] to the desired values in volts from -12 to +12.	0.0
:VOLTage? <clist>	Query the present voltage for the analog output channel[s].	
:DIGital	Path to the digital commands.	
:BYTE <nrf>,<clist>	Force the digital output of the given channel[s] to the desired value (0 < x ≤ 255) in decimal format.	255
:BYTE? <clist>	Query the present bit pattern (0 < x ≤ 255) for the digital output channels.	
:WORD <nrf>,<clist>	Force the digital output of the given channel[s] to the desired value (0 < x ≤ 65535) in decimal format.	65535
:WORD? <clist>	Query the present bit pattern (0 < x ≤ 65535) for the digital output channels (returned in decimal format).	
<p>Channel list parameter: <clist> = (@SCH) where: S = Mainframe slot number (1 or 2); CH = Switching module channel number (must be 2 digits);</p> <p>Examples: (@101) = Slot 1, Channel 1 (@101, 203) = Slot 1, Channel 1 and Slot 2, Channel 3 (@101:110) = Slot 1, Channels 1 through 10</p>		

:OUTPut

As mentioned in Table 3, Channels 21 and 22 are eight-bit digital output channels, and Channels 23 and 24 are analog output channels with a range of -12V to +12V. For individual digital channels, the range of values allowed is 0-255, and the outputs are set to the closest integer to the sent value. Analog outputs will accept values of -12 to +12. Attempting to use this command with an input channel generates error -221 settings conflict.

:VOLTage <nrf>,<clist>

Force voltage

:VOLTage? <clist>

Query voltage

Use to force (or query) the analog output of the given channel[s] to the desired value. Values are rounded to the nearest mV. (-12VDC < x < +12VDC).

:DIGital

:BYTE <nrf>,<clist> — Use to force the digital output of the given channel[s] to the desired value (0 < x < 255) in decimal format. Use this command to write to Channel 21 or 22 individually. Bit 0 of each port is the LSB.

:BYTE? <clist> — Query the present bit pattern (0 < x < 255) for the digital output channels (returned in decimal format). Use this command to query Channel 21 or 22 individually.

:WORD <nrf>,<clist> — Must write to the lower port (channel 21). Channel 21 bit 0 will be the LSB and Channel 22 bit 7 will be the MSB.

:WORD? <clist> — Query the present bit pattern (0 < x < 65535) for the digital output channels (returned in decimal format). This command must be sent to Channel 21.

SENSe[1] Subsystem

Commands to perform Model 7706 specific operations are listed in Table 5.

Table 5

Sense1 subsystem commands

Command	Description	Default
:SENSe[1]	Path to the :SENSe[1] commands.	
:TOTAlize	Path to configure 7706 Totalizer.	
:TYPE < READ RRESet >,<clist>	RRESet (read and reset) causes the Totalizer count to be reset to zero every time it is read.	READ
:TYPE? <clist>	Query Totalizer count readback type.	
:EDGE < RISing FALLing >,<clist>	Set which edge of the input signal to count.	RIS
:EDGE? <clist>	Query trigger edge for the Totalizer.	
:DATA? <clist>	Query the current Totalizer count. This command will reset the count to 0 if TOT:TYPE is set to RRESet.	
<p>Channel list parameter: <clist> = (@SCH) where: S = Mainframe slot number (1 or 2); CH = Switching module channel number (must be 2 digits);</p> <p>Examples: (@101) = Slot 1, Channel 1 (@101, 203) = Slot 1, Channel 1 and Slot 2, Channel 3 (@101:110) = Slot 1, Channels 1 through 10</p>		

Unsupported SCPI commands

NOTE

The display will indicate which cards are installed immediately after showing the firmware revision at power-up.

The ROUT:SCAN:NVOLatile command is not supported for Model 7706 module operation. Attempts to set ROUT:SCAN:NVOL ON with a 7706 card present in either slot will generate error -221 settings conflict.

Verification

Use the procedures contained in this section to verify the analog outputs or the Totalizer.

Analog outputs

WARNING

The information contained in this section is intended only for qualified service personnel. Do not attempt these procedures unless you are qualified to do so.

NOTE

After correctly wiring the Model 7706, installing it in the Model 2700, and turning the power on (step 5 in the following procedure), the unit is required to warm up for two hours before proceeding.

Use the following steps to verify the Model 7706 analog output channels.

1. Connect CH23 H and L outputs to CH1 H and L input terminals (respectively).
2. Connect CH24 H and L outputs to CH2 H and L input terminals (respectively).
3. Close and lock the Model 7706 cover.
4. Install the Model 7706 in slot 1 of the Model 2700.
5. Turn on the Model 2700.
6. Allow unit to warm up for two hours before proceeding.
7. Set the front panel INPUTS switch to the REAR position.
8. Set the Model 2700 to the 10V range:
 - a. Select the DC volts function by pressing the DCV key.
 - b. Select the 10V range.
9. Close channel 1:
 - a. Press the CLOSE key.
 - b. Key in 101.
10. Set analog output 1 to +10V:
 - a. Open the SHIFT-CARD menu (press SHIFT-CARD).
 - b. Key in analog output for AOUT1:+10.000V.
11. Verify analog output reading is within stated limits (see Table 6).
12. Set analog output 1 to -10V:
 - a. Open the SHIFT-CARD menu (press SHIFT-CARD).
 - b. Key in analog output for AOUT1:-10.000V.
13. Verify analog output reading is within stated limits.

14. Close channel 2:
 - a. Press the CLOSE key.
 - b. Key in 102.
15. Set analog output 2 to +10V:
 - a. Open the SHIFT-CARD menu (press SHIFT-CARD).
 - b. Key in analog output for AOUT2:+10.000V.
16. Verify analog output reading is within stated limits.
17. Set analog output 2 to -10V:
 - a. Open the SHIFT-CARD menu (press SHIFT-CARD).
 - b. Key in analog output for AOUT2:-10.000V.
18. Verify analog output reading is within stated limits.
19. Open channel 2 (press the OPEN key).

Figure 24
Verification—*analog connections*

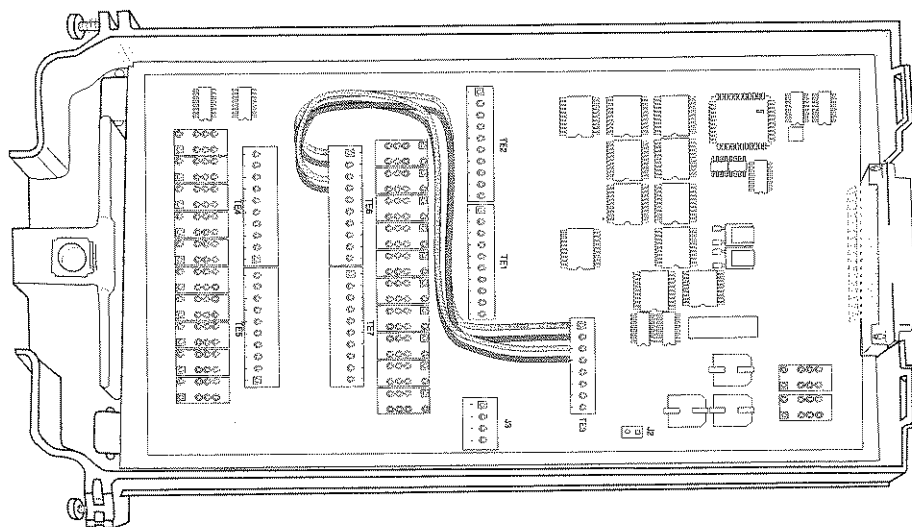

Table 6
Analogue output limits

Source DC Voltage	Reading limits (1 year, 18° to 28°C)
+10V	+9.966 to +10.034V 0.15% of reading + 19mV
-10V	-10.034 to -9.966V

Totalizer

WARNING

The information contained in this section is intended only for qualified service personnel. Do not attempt these procedures unless you are qualified to do so.

NOTE

Correctly wire and install the Model 7706 in the Model 2700 before turning on the Model 2700.

Use the following steps to verify the Model 7706 Totalizer function.

1. Connect the function generator to the Model 7706 Totalizer IN+ and IN- terminals (see Figure 25).
2. Make sure to leave gate inputs (G+ and G-) open (gate always).
3. Set the threshold jumper to the TTL position (J2 closed).
4. Close and lock the Model 7706 cover.

NOTE

Make sure the Model 2700 is OFF before installing the Model 7706.

5. Install the Model 7706 in slot 1 of the Model 2700.
6. Turn on the Model 2700.
7. Set the function generator to:
 - Burst mode
 - Burst cycle count of 50,000
 - Manual trigger source
 - Output: 100kHz
 - 0–5V square wave (50% duty cycle)
8. Close CH25:
 - a. Press the CLOSE key.
 - b. Key in 125.
9. Check Totalizer count — if count is not zero press EXIT key to clear count.
10. Verify that each time the function generator is triggered to output a burst, the Totalizer count increases by 50,000.
11. Open CH25:
12. Press the OPEN key.

Figure 25
Verification—Totalizer connections

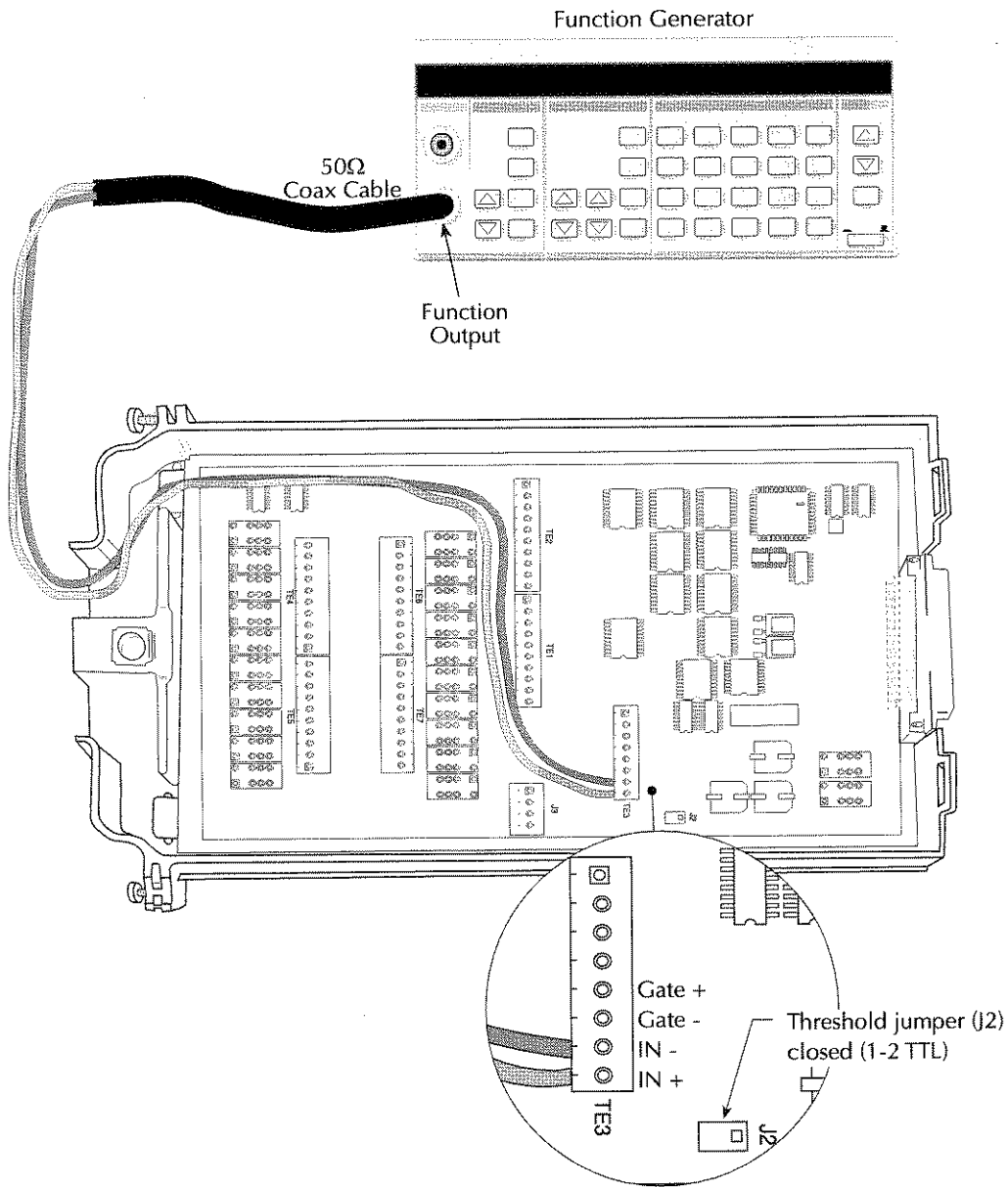

Calibration

The following procedures calibrate the temperature sensors on the Model 7706 plug-in module as well as the analog outputs.

Recommended test equipment

In order to calibrate the Model 7706, you will need equipment summarized in Table 7.

Extender board connections

The Model 7706 being calibrated should be connected to the 7798-250B Calibration/Extender Board, and the extender board must be installed in scanner Slot #1. Note that the module being calibrated will be external to the Model 2700 to avoid card heating during calibration.

Table 7

Recommended calibration equipment

Description
Digital thermometer: 18° to 28°C, ±0.1°C
Keithley 7798-250B Calibration Extender Board

Front panel Model 7706 temperature calibration

NOTE

Before calibrating the temperature on the Model 7706, make sure that power has been removed from the card for at least two hours to allow card circuitry to cool down. After turning on the power during the calibration procedure, complete the procedure as quickly as possible to minimize card heating that could affect calibration accuracy. Allow the Model 2700 to warm up for at least two hours.

1. Connect the Model 7706 to the 7798-250B Calibration Extender Board.
2. With the power off, install the Model 7706/7798 combination in Slot 1, and select the rear inputs with the INPUTS switch.
3. Press in and hold the Model 2700 OPEN key while turning on the power.
4. Allow five minutes for thermal equilibrium.
5. Accurately measure and record the cold temperature of the Model 7706 card surface at the center of the card.
6. Press SHIFT then TEST, then display TEST:CALIB with the up or down range key. Press ENTER, select RUN, then enter the appropriate calibration code (default: 002700).
7. Using the up or down range key, select CARD at the CAL:RUN prompt, then press ENTER.
8. Using the up or down range key, select TEMP, then press ENTER.
9. Set the display value to the cold junction calibration temperature (°C) measured in step 4, then press ENTER to complete Model 7706 temperature calibration.

Remote Model 7706 temperature calibration

1. Connect the Model 7706 to the 7798-250B Calibration/Extender Board.
2. With the power off, install the Model 7706/7798 combination in Slot 1, and select the rear inputs with the INPUTS switch.
3. Press in and hold the Model 2700 OPEN key while turning on the power.
4. Allow five minutes for thermal equilibrium.
5. Accurately measure and record the cold temperature of the Model 7706 card surface at the center of the card.
6. Turn on the Model 2700 power.
7. Unlock calibration by sending:
:DIAG:KEIT:CAL:UNLOCK
8. Enable calibration by sending the :CODE command. For example, the default command is:
:CAL:PROT:CODE 'KI002700'
9. Initiate calibration by sending the following command:
:CAL:PROT:CARD1:INIT
10. Calibrate temperature on the Model 7706 with the following command:
:CAL:PROT:CARD1:STEP0 <temp>

Here <temp> is the cold calibration temperature measured in step 4.
11. Send the following commands to save calibration, and lock out calibration:
:CAL:PROT:CARD1:SAVE
:CAL:PROT:CARD1:LOCK

Front panel Model 7706 analog output (DAC) calibration

1. Connect the Model 7706 CH23 and 24 to CH1 and 2 (use the same connection setup as in Figure 24):
 - Connect CH23 H and L terminals to CH1 H and L terminals (H to H; L to L).
 - Connect CH24 H and L terminals to CH2 H and L terminals (H to H; L to L).
2. With the power off, install the Model 7706 in Slot 1, and select the rear inputs with the INPUTS switch.
3. Press in and hold the Model 2700 OPEN key while turning on the power.
4. Allow unit to warm up for two hours before proceeding.
5. Press the SHIFT key and then the TEST key.
6. Select TEST:CALIB using the up or down range keys.
7. Press the ENTER key, select RUN, and enter the appropriate calibration code (default: 002700).
8. Using the up or down range key, select CARD at the CAL:RUN prompt, then press ENTER.
9. Using the up or down range key, select DAC at the next CARD prompt, then press ENTER to complete Model 7706 DAC calibration.

Remote Model 7706 analog output (DAC) calibration

1. Connect the Model 7706 CH23 and 24 to CH1 and 2 (use the same connection setup as in Figure 24):
 - Connect CH23 H and L terminals to CH1 H and L terminals (H to H; L to L).
 - Connect CH24 H and L terminals to CH2 H and L terminals (H to H; L to L).
2. With the power off, install the Model 7706 in Slot 1, and select the rear inputs with the INPUTS switch.
3. Turn on the Model 2700 power.
4. Allow unit to warm up for two hours before proceeding.
5. Unlock calibration by sending:
:DIAG:KEIT:CAL:UNLOCK
6. Enable calibration by sending the :CODE command. For example, the default command is:
:CAL:PROT:CODE 'KI002700'
7. Initiate calibration by sending the following command:
:CAL:PROT:CARD1:INIT
8. Calibrate the Model 7706 analog output with the following command:
:CAL:PROT:CARD1:DAC:STEP0
9. Send the following commands to save calibration, and lock out calibration:
:CAL:PROT:CARD1:SAVE
:CAL:PROT:CARD1:LOCK

Calibration commands

Table 8 summarizes calibration commands for the Model 7706 plug-in module. Note that CARD1 commands calibrate the card in Slot 1, while CARD2 commands request calibration count and date information from a card in Slot 2.

NOTE

The 7706 must be installed in Slot 1 through a Model 7798 extender card to perform temperature calibration.

Table 8
Model 7706 calibration commands

Command	Description
:CALibration	Calibration root command.
:PROTECTED	All commands in this subsystem are protected by the calibration lock (except queries and :CODE).
:CODE '<up to 8 char. string>'	Send calibration code. (Default KI002700)
:CARD1	Path to card in slot 1.
:INITiate	Initiate card calibration.
:COUNt?	Request number of times card had been calibrated.
:RCOUNt	Reset card calibration count to 0.
:DATE?	Request card calibration date.
:SAVE	Save cal constants to card EEPROM.
:LOCK	Lock out calibration.
:LOCK?	Request cal lock state. (0 = locked, 1 = unlocked)
:STEP0 <NRf>	Temperature sensor cold calibration (<NRf> = temperature, °C).
:DAC	Path to analog output calibration.
:STEP0 <NRf>	Analog output DAC calibration.
:CARD2	Path to card in slot 2.
:COUNt?	Request number of times card has been calibrated.
:DATE?	Request card calibration date.
:DIAGnostic	Diagnostic root.
:KEITHley	Keithley path.
:CALibration	Calibration path.
:UNLOCK	Unlock command.

:CODE

(:CALibration:PROTeCted:CODE)

NOTES

The :CODE command should be sent only once before performing calibration. Do not send :CODE before each calibration step.

The code parameter must be enclosed in single quotes.

Purpose	To program the calibration code or password so that you can perform the Model 7706 calibration procedures.
Format	:CAL:PROT:CODE '<CHAR_STRING>'
Parameter	Up to a 8-character string including letters and numbers.
Description	The :CODE command enables the Model 2700 calibration procedures when performing these procedures over the bus. This command must be sent to the unit before sending any other Model 7706 calibration command. The default calibration code is KI002700.
Example	:CAL:PROT:CODE 'KI002700' Send default code of KI002700.

:COUNT?

(:CALibration:PROTeCted:CARD1:COUNT?)

(:CALibration:PROTeCted:CARD2:COUNT?)

Purpose	To determine how many times a Model 7706 has been calibrated.
Format	:CAL:PROT:CARD1:COUN? :CAL:PROT:CARD2:COUN?
Response	<n> Calibration count.
Description	The :CARD1:COUNT? and :CARD2:COUNT? commands allow you to determine how many times a Model 7706 in Slot 1 and Slot 2, respectively, has been calibrated.

NOTE

Use the :COUNT? command to help you monitor for unauthorized calibration procedures.

Example	:CAL:PROT:CARD1:COUN?	Request card 1 calibration count.
----------------	-----------------------	-----------------------------------

:DATE?**(:CALibration:PROTeCted:CARD1:DATE?)****(:CALibration:PROTeCted:CARD2:DATE?)**

Purpose To request the Model 7706 calibration date.

Format :CAL:PROT:CARD1:DATE?
:CAL:PROT:CARD2:DATE?

Response <year>, <month>, <day>

Description The :CARD1:DATE? and :CARD2:DATE? queries allow you to read back the calibration date from a Model 7706 in Slot 1 and Slot 2 respectively.

NOTE

The card calibration date is automatically set to the Model 2700 real time clock date when the card is calibrated.

Example :CAL:PROT:CARD1:DATE? Request card 1 cal date.

:INIT**(:CALibration:PROTeCted:CARD1:INITiate)**

Purpose To initiate Model 7706 calibration procedures.

Format :CAL:PROT:CARD1:INIT

Parameter None

Description The :INIT command enables Model 7706 calibration when performing these procedures over the bus. This command must be sent to the unit after sending the :CODE command, but before performing Model 7706 calibration.

Example :CAL:PROT:CARD1:INIT Initiate 7706 calibration.

:LOCK**(:CALibration:PROTeCted:CARD1:LOCK)**

Purpose To lock out Model 7706 calibration.

Format :CAL:PROT:CARD1:LOCK

Parameter None

Description The :LOCK command allows you to lock out Model 7706 calibration after completing the procedure. Thus, :LOCK performs the opposite of enabling calibration with the :CODE command.

Example :CAL:PROT:CARD1:LOCK Lock out card 1 calibration.

:LOCK?

(:CALibration:PROTeCted:CARD1:LOCK?)

Purpose	To read Model 7706 calibration lock status.	
Format	:CAL:PROT:CARD1:LOCK?	
Response	0 Calibration locked. 1 Calibration unlocked.	
Description	The :LOCK? query requests status from the Model 2700 on Model 7706 calibration locked/unlocked state. Calibration must be enabled sending the :CODE command before calibration can be performed.	
Example	:CAL:PROT:CARD1:LOCK?	Request card 1 cal lock state.

:SAVE

(:CALibration:PROTeCted:CARD1:SAVE)

Purpose	To save calibration constants in card EEROM after the calibration procedure.	
Format	:CAL:PROT:CARD1:SAVE	
Parameter	None	
Description	The :SAVE command stores calculated calibration constants derived during Model 7706 calibration in card EEROM. (EEROM is non-volatile memory.) Calibration constants will be retained indefinitely once saved. Generally, :SAVE is sent after all other calibration steps (except for :LOCK).	

NOTE

Card calibration will be only temporary unless the :SAVE command is sent to permanently store calibration constants.

Example	:CAL:PROT:CARD1:SAVE	Save card calibration constants.
----------------	----------------------	----------------------------------

:STEP0**(:CALibration:PROTected:CARD1:STEP0)**

Purpose	To perform Model 7706 temperature calibration.
Format	:CAL:PROT:CARD1:STEP0 <TEMP>
Parameter	<temp> = Cold calibration temperature (°C)
Description	:STEP0 performs temperature sensor calibration of the Model 7706. The card must be allowed to cool down to ambient temperature before calibration, and the cold temperature of the card must be measured and sent as the <temp> parameter during calibration.

NOTE

Before calibrating the temperature for the Model 7706, make sure that power has been removed from the card for at least two hours to allow card circuitry to cool down. After turning on the power during the calibration procedure, complete the procedure as quickly as possible to minimize card heating that could affect calibration accuracy.

Example	:CAL:PROT:CARD1:STEP0 23	Perform 7706 temperature calibration with card at a temperature of 23°C (measured with an external probe).
----------------	--------------------------	--

:DAC**:STEP0****(:CALibration:PROTected:CARD1:DAC:STEP0)**

Purpose	To perform Model 7706 analog output (DAC) calibration.
Format	:CAL:PROT:CARD1:DAC:STEP0
Parameter	none
Description	:STEP0 performs analog output calibration of the Model 7706. The card must be allowed to warm up inside the powered-up unit for two hours before calibration. In this step, CH23 (analog output 1) must be connected to CH1, and CH24 (analog output 2) must be connected to CH2.
Example	:CAL:PROT:CARD1:DAC:STEP0 Perform 7706 DAC calibration.

(:CALibration:PROTected:CARD1:STEP0)

- Purpose** To perform Model 7706 temperature calibration.
- Format** :CAL:PROT:CARD1:STEP0 <TEMP>
- Parameter** <temp> = Cold calibration temperature (°C)
- Description** :STEP0 performs temperature sensor calibration of the Model 7706. The card must be allowed to cool down to ambient temperature before calibration, and the cold temperature of the card must be measured and sent as the <temp> parameter during calibration.

NOTE

Before calibrating the temperature on the Model 7706, make sure that power has been removed from the card for at least two hours to allow card circuitry to cool down. After turning on the power during the calibration procedure, complete the procedure as quickly as possible to minimize card heating that could affect calibration accuracy.

Example :CAL:PROT:CARD1:STEP0 23 Perform 7706 calibration.

Remote error reporting

Methods to detect and determine the nature of calibration errors are discussed below.

Error summary

Table 9 summarizes Model 2700 calibration errors.

Table 9
Calibration error summary

Error number and description	Error number and description
+400, "10 vdc zero error"	+455, "100m vac full scale error"
+401, "100 vdc zero error"	+456, "1 vac zero error"
+402, "10 vdc full scale error"	+457, "1 vac full scale error"
+403, "-10 vdc full scale error"	+458, "1 vac noise error"
+404, "100 vdc full scale error"	+459, "10 vac zero error"
+405, "-100 vdc full scale error"	+460, "10 vac full scale error"
+406, "1k 2-w zero error"	+461, "10 vac noise error"
+407, "10k 2-w zero error"	+462, "100 vac zero error"
+408, "100k 2-w zero error"	+463, "100 vac full scale error"
+409, "10M 2-w zero error"	+464, "750 vac zero error"
+410, "10M 2-w full scale error"	+465, "750 vac full scale error"
+411, "10M 2-w open error"	+466, "750 vac noise error"
+412, "1k 4-w zero error"	+467, "Post filter offset error"
+413, "10k 4-w zero error"	+468, "1 aac zero error"
+414, "100k 4-w zero error"	+469, "1 aac full scale error"
+415, "10M 4-w sense lo zero error"	+470, "3 aac zero error"
+416, "1k 4-w full scale error"	+471, "3 aac full scale error"
+417, "10k 4-w full scale error"	+472, "Input time constant error"
+418, "100k 4-w full scale error"	+473, "Frequency gain error"
+419, "1M 4-w full scale error"	+474, "1K Ohm Ioff Ocomp FS error"
+420, "10M 4-w full scale error"	+475, "10K Ohm Ioff Ocomp FS error"
+421, "10m adc zero error"	+476, "Temperature Cold Cal error"
+422, "100m adc zero error"	+477, "Analog output zero error" *
+423, "10m adc full scale error"	+478, "Analog output pos. gain error" *
+424, "100m adc full scale error"	+479, "Analog output neg. gain error" *
+425, "1 adc full scale error"	+500, "Calibration data invalid"
+438, "Date of calibration not set"	+513, "AC calibration data lost"
+439, "Next date of calibration not set"	+514, "DC calibration data lost"
+450, "100m vac dac error"	+515, "Calibration dates lost"
+451, "1 vac dac error"	+518, "Card calibration data lost"
+452, "10 vac dac error"	+519, "Card calibration dates lost"
+453, "100 vac dac error"	+610, "Questionable calibration"
+454, "100m vac zero error"	

*Model 7706 card specific.

Error queue

As with other Model 2700 errors, any calibration error will be reported in the bus error queue. You can read this queue by using the :SYST:ERR? query. The Model 2700 will respond with the appropriate error message, as summarized in Table 9.

Status byte EAV (Error Available) bit

Whenever an error is available in the error queue, the EAV (Error Available) bit (bit 2) of the status byte will be set. Use the *STB? query or serial polling to obtain the status byte, then test bit 2 to see if it is set. If the EAV bit is set, an error has occurred, and you can use the :SYST:ERR? query to read the error and at the same time clear the EAV bit in the status byte.

Generating an SRQ on error

To program the instrument to generate an IEEE-488 bus SRQ when an error occurs, send the following command: *SRE 4. This command will enable SRQ when the EAV bit is set. You can then read the status byte and error queue as outlined above to check for errors, and to determine the exact nature of the error.

Detecting calibration step completion

When sending remote calibration commands, you must wait until the instrument completes the current operation before sending a command. You can use either *OPC? or *OPC to help determine when each calibration step is completed.

Using the *OPC? query

With the *OPC? (operation complete) query, the instrument will place an ASCII 1 in the output queue when it has completed each step. To determine when the OPC response is ready, do the following:

1. Repeatedly test the MAV (Message Available) bit (bit 4) in the status byte and wait until it is set. (You can request the status byte by using the *STB? query or by serial polling.)
2. When MAV is set, a message is available in the output queue, and you can read the output queue and test for an ASCII 1.
3. After reading the output queue, repeatedly test MAV again until it clears. At this point, the calibration step is completed.

Using the *OPC command

The *OPC (operation complete) command can also be used to detect the completion of each calibration step. To use *OPC to detect the end of each calibration step, you must do the following:

1. Enable operation complete by sending *ESE 1. This command sets the OPC (operation complete bit) in the standard event enable register, allowing operation complete status from the standard event status register to set the ESB (event summary bit) in the status byte when operation complete is detected.
2. Send the *OPC command immediately following each calibration command. For example:
:CAL:PROT:DC:STEP1;*OPC

Note that you must include the semicolon (;) to separate the two commands, and that the *OPC command must appear on the same line as the calibration command.

3. After sending a calibration command, repeatedly test the ESB (Event Summary) bit (bit 5) in the status byte until it is set. (Use either the *STB? query or serial polling to request the status byte.)
4. Once operation complete has been detected, clear OPC status using one of two methods: (1) Use the *ESR? query, then read the response to clear the standard event status register, or (2) send the *CLS command to clear the status registers. Note that sending *CLS will also clear the error queue and operation complete status.

Generating an SRQ on calibration complete

An IEEE-488 bus SRQ (service request) can be used to detect operation complete instead of repeatedly polling the Model 2700. To use this method, send both *ESE 1 and *SRE 32 to the instrument, then include the *OPC command at the end of each calibration command line, as covered above. Refer to your controller's documentation for information on detecting and servicing SRQs.

Replaceable parts

Introduction

This section contains replacement parts information and component layout drawings for the Model 7706.

Parts lists

Both electrical and mechanical parts for the Model 2700 are listed in several tables on the following pages.

Ordering information

To place an order, or to obtain information concerning replacement parts, contact your Keithley representative or the factory (see inside front cover for addresses). When ordering parts, be sure to include the following information:

- Card model number (Model 7706 module)
- Card serial number
- Part description
- Component designation (if applicable)
- Keithley part number

Factory service

If the instrument is to be returned to Keithley Instruments for repair, perform the following:

- Call the Repair Department at 1-888-KEITHLEY for a Return Material Authorization (RMA) number.
- Complete the service form at the back of this manual, and include it with the instrument.
- Carefully pack the instrument in the original packing carton.
- Write ATTENTION REPAIR DEPARTMENT and the RMA number on the shipping label.

Component layout

A component layout for the Model 7706 circuit board is provided on the pages following the Model 7706 parts list (Table 10).

Table 10
Model 7706 parts list

Circuit Designation	Description	Keithley Part No.
C1,C2,C3,C4,C6	CAP, 1000PF, 10%, 50V, MONO CERAMIC	C-452-1000P
C13	CAP, 47P, 5%, 100V, CERAMIC	C-465-47P
C14	CAP, 47P, 5%, 100V, CERAMIC	C-465-47P
C16	CAP, 22U, 20%, 25V, TANTALUM	C-535-22
C17,C22,C23	CAP, 0.47U, 20%, 25V	C-520-47
C18,C19,C20,C21,C28,C29	CAP, 100P, 10%, 100V, CERAMIC	C-451-100P
C39,C40	CAP, 47UF, 20%, 20%, TANTALUM	C-575-47
C41	CAP, 10UF, 20%, 25V, TANTALUM	C-440-10
C42,C43,C44,C45	CAP, 1000P, 10%, 100V, CERAMIC	C-451-1000P
C47	CAP, 1000pF, 20%, 50V, CERAMIC	C-418-1000P
C48	CAP, 0.01uF, 20%, 50V, CERAMIC	C-418-.01
C7-C9,C10-12,C24-C27,C30-C35,38,46,49-53	CAP, 0.1UF, 20%, 50V, CERAMIC	C-418-1
CR2-6,25,28,42,44,46,48,43,45,47,49,50	DIODE, DUAL SWITCHING, BAV99L	RF-82
CR26,CR27	DIODE, DUAL HSM-2822T31	RF-95

Table 10 (Continued)
Model 7706 parts list

Circuit Designation	Description	Keithley Part No.
CR29,CR30,CR40,CR41	DUAL HIGH SPEED DIODE	RF-147
CR31,32,34,36,38,1,33,35,37,39	DIODE, DUAL SWITCHING, BAV99L	RF-82
CR51-CR54	DIODE, DUAL SWITCHING, BAV99L	RF-82
CR7-CR22	DIODE, DUAL COMMON ANODE	RF-98
	BAW56LT2	
J1	CONN, RT ANGLE DUAL ROW RECEIPT	CS-1065-1
J2	CONN, BERG	CS-339
K1-K20,K23	SINGLE COIL LATCHING	RL-244
K21,K22	NON LATCHING RELAY	RL-243
L1,L2,L3,L4	FERRITE CHIP, 600 OHM, BLM32A07	CH-62
Q1,Q2,Q3,Q4,Q53,Q54,Q56,Q58	TRANS, NPN SILICON	TG-389
Q25,27,29,31,33,35,37,39,41,43,45,47,49	TRANS, PNP SILICON	TG-388
Q26,28,30,32,34,36,38,40,42,44,46,48,50	TRANS, NPN SILICON	TG-389
Q5,Q6	P CHANNEL TMOSFET	TG-392
Q51	TRANS, PNP SILICON	TG-388
Q52	TRANS, NPN SILICON	TG-389
Q55,Q57	TRANS, PNP SILICON	TG-388
Q9-Q24	TRANS, N-MEGAFET, RFD14N05LSM	TG-267
R122,R126,R30	RES, ARRAY, 4x10K, 5%, 0.125W	TF-276-10K
R13,R14,R17,R18	RES, 499K, 1%, 125MW, METAL FILM	R-391-499K
R19,R21	RES, 332, 10%, 125MW, METAL FILM	R-391-332
R1-R12,R15,R16	RES, 13K, 1%, 125MW, METAL FILM	R-391-13K
R20,R22	RES, 2K, 1%, 125mW, METAL FILM	R-391-2K
R23	RES, 28.7K, 1%, 0.125W, METAL FILM	R-391-28.7K
R24,R25	RES, 4.75K, 1%, 125mW, METAL FILM	R-391-4.75K
R26	RES, 49.9K, 1%, 125MW, METAL FILM	R-391-49.9K
R27	RES, 4.99K, 1%, 125mW, METAL FILM	R-391-4.99K
R28,32-34,39,59-63,73,74,76,77	RES, 220, 5%, 125MW, METAL FILM	R-375-220
R29,R86,R87	RES, ARRAY, 4x4.3K, 5%, 0.125W	TF-276-4.3K
R31,R38,R40	RES, 475, 1%, 100MW, THICK FILM	R-418-475
R36,R37,R41-R46,R75,R85,R35	RES, 1K, 5%, 125MW, METAL FILM	R-375-1K
R51,R52,R55,R56	RES, ARRAY, 4x100K, 5%, 0.125W	TF-276-100K
R53,54,57,58,94-97,100-102	RES, ARRAY, 4x10K, 5%, 0.125W	TF-276-10K
R64,R65,R66,R67	RES, 12.4, 10%, 100MW, THICK FILM	R-418-12.4K
R68,R69	RES, 40.2K, 1%, 100MW, THICK FILM	R-418-40.2K
R70,R71	RES, 54.9, 1%, 100MW, THICK FILM	R-418-54.9
R78,R79,R80,R81	RES, ARRAY, 4x1K, 5%, 0.125W	TF-276-1K
R82,R83	RES, 10K, 5%, 125MW, METAL FILM	R-375-10K
R84	RES, 100K, 5%, 125mW, METAL FILM	R-375-100K
RV1,RV2,RV3,RV4	BIDIRECTIONAL TRANSIENT VOLT SUPPRESSOR	VR-8
SO33	SOCKET	SO-143-44
TE1,TE2	CONN, FEMALE 12-PIN	TE-118-12
TE3,TE4,TE5,TE6,TE7	CONN, FEMALE 16-PIN	TE-118-10
TP1,TP2	CONN, TEST POINT	CS-553
U1	IC, VOLT. COMPARATOR, LM311M	IC-776
U12	IC, 8-CHAN ANA MULTIPLEXER, DG408DY	IC-844
U13,U23	IC, DUAL OPTO	IC-1358
U14,U15,U16,U17	IC, CENTIGRADE TEMP SENSOR LM35DM	IC-906
U18	IC, UNREGULATED DC/DC CONVERTER	IC-1355
U19,U20	IC, 16-BIT MONOLITHIC PCM AUDIO DAC	IC-1136
U2	IC, QUAD 2-INPUT NAND, 74HC00M	IC-781
U21,U22	IC, OPA177GS	IC-960
U24,U34	IC, TINYLOGIC CMOS INVERTER	IC-1282

Table 10 (Continued)
Model 7706 parts list

Circuit Designation	Description	Keithley Part No.
U24,U34,U11,U26,U29,U7,U8,U9	IC, OCTAL D FLIP FLOP	IC-1353
U25	IC, -5V VOLTAGE REGULATOR	IC-1171
U3	IC, 8 STAGE SHIFT/STORE, MC14094BD	IC-772
U30,U31	IC, OCTAL BUFFER	IC-1252
U32	IC, 2.5V, CASCADABLE SERIAL EEPROM	LSI-212
U33	IC, 8-BIT MICROCONTROLLER	LSI-242
U4,U5	IC, SCHMITT-TRIGGER NAND GATE	IC-950
U6,U10	IC, 3-TO-8 LINE DECODE, 74ACT138	IC-654
VR1,VR2	DIODE ZENER 12V, MMSZ12T1	DZ-112
Y1	CRYSTAL CERAMIC RESONATOR, 8M	CR-59-2
MECHANICAL PARTS	TOP COVER HEAT STAKE ASSEMBLY	7700-302A
	BOTTOM CARD COVER	7702-301C
	COMPRESSION SPRING	SP-7-3

Figure 26
Component layout (Side-04)

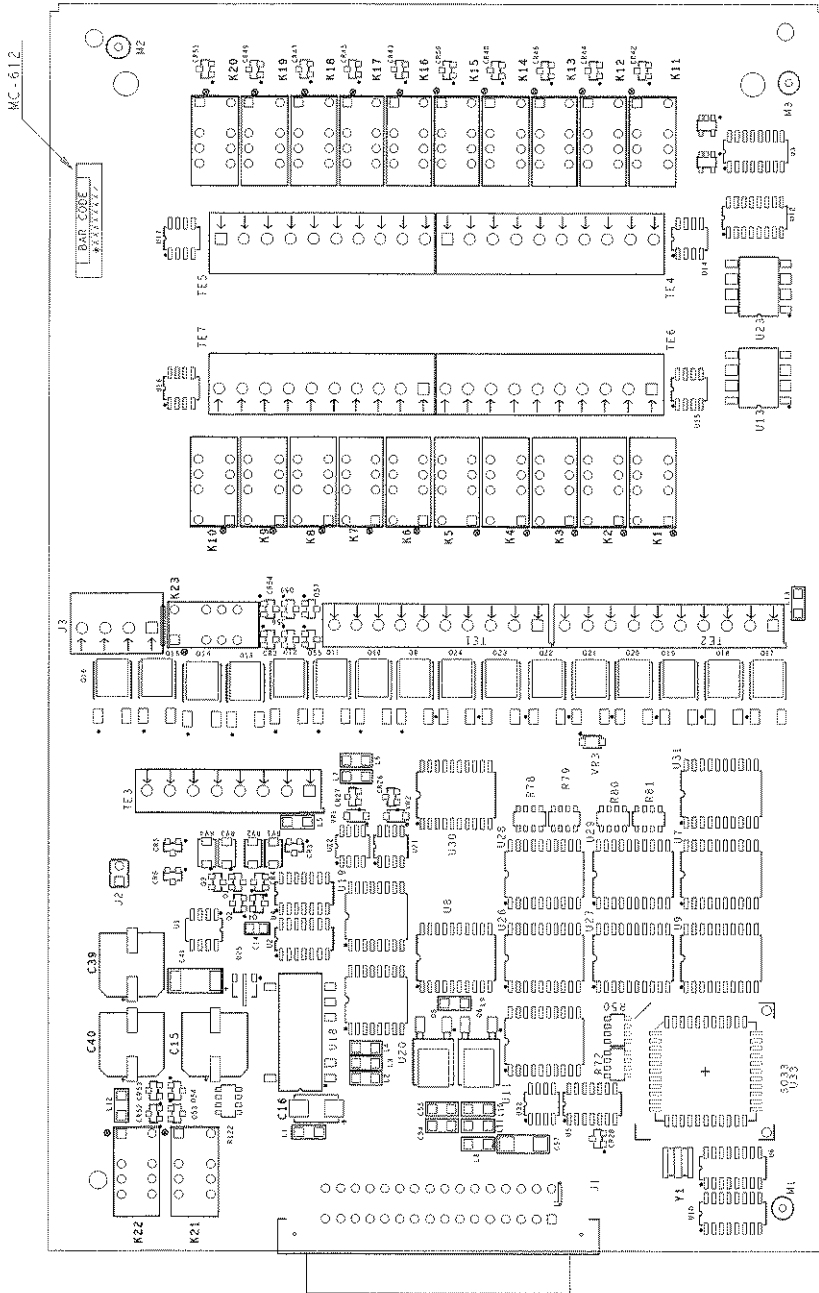

PRIMARY SIDE COMPONENTS (SIDE-04)

Figure 27
Component layout (Side-01)

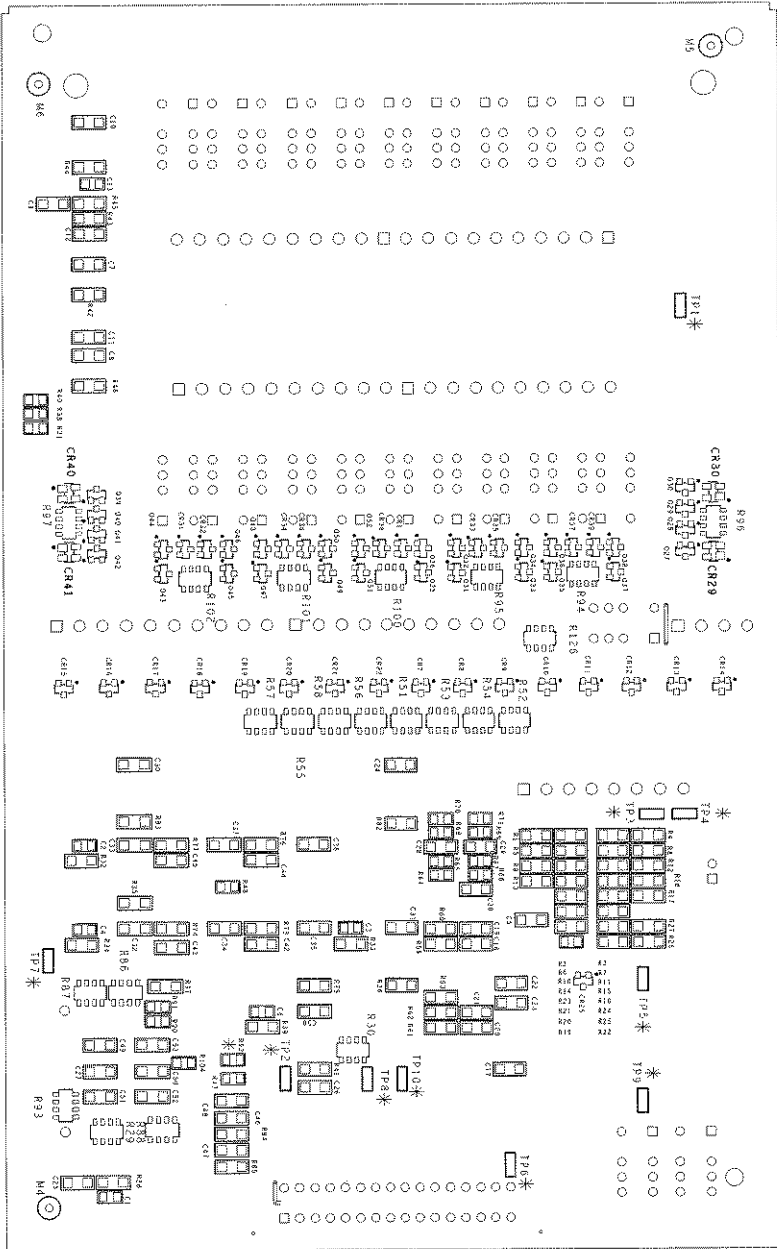

SECONDARY SIDE COMPONENTS (SIDE-01)

Model 2700 Specifications

DC CHARACTERISTICS¹

CONDITIONS: MED (1 PLC)² or 10 PLC or MED (1 PLC) with Digital Filter of 10

ACCURACY: ±(ppm of reading + ppm of range)

INPUT (ppm = parts per million)

FUNCTION	RANGE	RESOLUTION	TEST CURRENT		RESISTANCE (e.g., 10ppm = 0.001%)	TEMPERATURE	COEFFICIENT		
			OR BURDEN	NOR OPEN CKT.			24 Hour ⁴	90 Day/1 Year	23°C±5°
			VOLTAGE	VOLTAGE					
Voltage ¹¹	100.0000	mV	0.1 μV		>10 GΩ	15 + 30	25 + 35	30 + 35	(1 + 5)/°C
	1.000000	V	1.0 μV		>10 GΩ	15 + 6	25 + 7	30 + 7	(1 + 1)/°C
	10.000000	V	10 μV		>10 GΩ	10 + 4	20 + 5	30 + 5	(1 + 1)/°C
	100.0000	V	100 μV		10 MΩ ± 1%	15 + 6	35 + 9	45 + 9	(5 + 1)/°C
	1000.0000	V ⁵	1 mV		10 MΩ ± 1%	20 + 6	35 + 9	50 + 9	(5 + 1)/°C
Resistance ^{6,8}	100.0000	Ω	100 μΩ	1 mA	6.6 V	20 + 20	80 + 20	100 + 20	(8 + 1)/°C
	1.000000	kΩ	1 mΩ	1 mA	6.6 V	20 + 6	80 + 6	100 + 6	(8 + 1)/°C
	10.000000	kΩ	10 mΩ	100 μA	6.6 V	20 + 6	80 + 6	100 + 6	(8 + 1)/°C
	100.0000	kΩ	100 mΩ	10 μA	12.8 V	20 + 6	80 + 10	100 + 10	(8 + 1)/°C
	1.000000	MΩ	1.0 Ω	10 μA	12.8 V	20 + 6	80 + 10	100 + 10	(8 + 1)/°C
	10.000000	MΩ ⁷	10 Ω	0.7 μA // 10M Ω	7.0 V	150 + 6	200 + 10	400 + 10	(30 + 1)/°C
	100.0000	MΩ ⁷	100 Ω	0.7 μA // 10M Ω	7.0 V	800 + 30	2000 + 30	2000 + 30	(150 + 1)/°C
Continuity (2W)	1.000	kΩ	100 mΩ	1 mA	6.6 V	40 + 100	100 + 100	100 + 100	(8 + 1)/°C
Current	20.00000	mA	10 nA	< 0.2 V		60 + 15	300 + 40	500 + 40	(50 + 5)/°C
	100.0000	mA	100 nA	< 0.05 V		100 + 150	300 + 400	500 + 400	(50 + 50)/°C
	1.000000	A	1.0 μA	< 0.3 V ⁹		200 + 15	500 + 40	800 + 40	(50 + 5)/°C
	3.000000	A	10 μA	< 1.0 V ⁹		1000 + 15	1200 + 40	1200 + 40	(50 + 5)/°C

Channel (Ratio)¹⁰ Ratio Accuracy = Accuracy of selected Channel Range + Accuracy of Paired Channel Range

Channel (Average)¹⁰ Average Accuracy = Accuracy of selected Channel Range + Accuracy of Paired Channel Range

TEMPERATURE¹⁹

(Displayed in °C, °F, or K. Exclusive of probe errors.)

Thermocouples (Accuracy based on ITS-90.)

Type	Range	Resolution	90 Day/1 Year (23°C ± 5°C)		Temperature Coefficient
			Relative to Simulated Reference Junction	Using CJC from Plug-In Module	
J	-200 to +760 °C	0.001°C	0.2°C	1.0°C	0.03°C/°C
K	-200 to +1372°C	0.001°C	0.2°C	1.0°C	0.03°C/°C
N	-200 to +1300°C	0.001°C	0.2°C	1.0°C	0.03°C/°C
T	-200 to +400°C	0.001°C	0.2°C	1.0°C	0.03°C/°C
E	-200 to +1000°C	0.001°C	0.2°C	1.0°C	0.03°C/°C
R	0 to +1768°C	0.1 °C	0.6°C	1.8°C	0.03°C/°C
S	0 to +1768°C	0.1 °C	0.6°C	1.8°C	0.03°C/°C
B	+350 to +1820°C	0.1 °C	0.6°C	1.8°C	0.03°C/°C

4-Wire RTD: (100Ω platinum (PT100), D100, F100, PT385, PT3916, or user type. Offset compensation On)

-200° to 630°C	0.01 °C	0.06°C	0.003°C/°C
----------------	---------	--------	------------

Thermistor: (2.2kΩ, 5kΩ, and 10kΩ.)

-80° to 150°C	0.01 °C	0.08°C	0.002°C/°C
---------------	---------	--------	------------

DC SPEED vs. NOISE REJECTION

Rate	Filter	Readings/s ¹²	Digits	RMS Noise 10V Range	NMRR	CMRR ¹⁴
10	50	0.1 (0.08)	6.5	< 1.2 μ V	110 dB ¹³	140 dB
1	Off	15 (12)	6.5	< 4 μ V	90 dB ¹³	140 dB
0.1	Off	500 (400)	5.5	< 22 μ V	—	80 dB
0.01	Off	2000 (1800)	4.5	< 150 μ V	—	80 dB

DC OPERATING CHARACTERISTICS¹⁵

60Hz (50Hz) Operation

FUNCTION	DIGITS	READINGS/s	PLCs
DCV, DCI, Ohms (<10M), Thermocouple, Thermistor	6.5 ^{12,16}	5 (4)	10
	6.5 ¹⁶	30 (24)	1
	6.5 ^{12,16}	50 (40)	1
	5.5 ^{12,16}	100 (80)	0.1
	5.5 ^{16,17}	250 (200)	0.1
	5.5 ¹⁷	480 (400)	0.1
	4.5 ¹⁷	2000 (1800)	0.01
4W Ohms (<10M)	6.5 ¹⁶	1.4 (1.1)	10
	6.5 ¹⁶	15 (1)	1
	5.5 ¹⁷	33 (25)	0.1
RTD	6.5 ¹⁶	0.9 (0.7)	10
	6.5 ¹⁶	8 (6.4)	1
	5.5 ^{16,17}	18 (14.4)	0.1
Channel (Ratio), Channel (AVG)	6.5 ¹⁶	2.5 (2)	10
	6.5 ¹⁶	15 (12)	1
	5.5 ¹⁷	25 (20)	0.1

DC SYSTEM SPEEDS^{15,18}

RANGE CHANGES¹⁹: 50/s (42/s).

FUNCTION CHANGES¹⁹: 50/s (42/s).

AUTORANGE TIME¹⁹: < 30ms.

ASCII READINGS TO RS-232 (19.2k BAUD): 55/s.

MAX. INTERNAL TRIGGER RATE: 2000/s.

MAX. EXTERNAL TRIGGER RATE: 375/s.

DC MEASUREMENT CHARACTERISTICS

DC Volts

A-D LINEARITY: 2.0 ppm of reading + 1.0 ppm of range.

INPUT IMPEDANCE:

100mV–10V Ranges: Selectable >10G Ω // with <400pF or 10M Ω \pm 1%.

100V, 1000V Ranges: 10M Ω \pm 1%.

INPUT BIAS CURRENT: <75pA at 23°C.

COMMON MODE CURRENT: <500nA at 50Hz or 60 Hz.

AUTOZERO ERROR: Add \pm (2ppm of range error + 5 μ V) for < 10 minutes and \pm 1°C.

INPUT PROTECTION: 1000V, all ranges. 300V with plug in modules.

Resistance

MAX 4W Ω LEAD RESISTANCE: 10% of range per lead for 100 Ω and 1k Ω ranges; 1k Ω per lead for all other ranges.

OFFSET COMPENSATION: Selectable on 4W Ω 100 Ω , 1k Ω , and 10k Ω ranges.

CONTINUITY THRESHOLD: Adjustable 1 to 1000 Ω

INPUT PROTECTION: 1000V, all Source Inputs, 350V Sense Inputs. 300V with plug-in modules.

DC Current

SHUNT RESISTORS: 100mA–3A, 0.1 Ω , 20mA, 5 Ω .

INPUT PROTECTION: 3A, 250V fuse.

Thermocouples

CONVERSION: ITS-90.

REFERENCE JUNCTION: Internal, External, or Simulated (Fixed).

OPEN CIRCUIT CHECK: Selectable per channel. Open >12kΩ.

EARTH ISOLATION: 500V peak, >10GΩ and <150pF any terminal to chassis.

DC Notes

- 20% overrange except on 1000V and 3A.
- Add the following to "ppm of range" uncertainty; 100mV 15ppm, 1V and 100V 2ppm, 100Ω 30ppm, <1MΩ 2ppm, 10mA and 1A 10ppm, 100mA 40ppm.
- ±2% (measured with 10MΩ input resistance DMM, >10GΩ DMM on 10MΩ and 100MΩ ranges).
- Relative to calibration accuracy.
- For signal levels >500V, add 0.02ppm/V uncertainty for portion exceeding 500V.
- Specifications are for 4-wire Ω, 100Ω with offset compensation on. With offset compensation on, OPEN CKT. VOLTAGE is 12.8V. For 2-wire Ω add 1Ω additional uncertainty.
- Must have 10% matching of lead resistance in Input HI and LO.
- Add the following to "ppm of reading" uncertainty when using plug in modules:

	10 kΩ	100 kΩ	1 MΩ	10 MΩ	100 MΩ
All Modules:				220 ppm	2200 ppm
7703 Module: for <40% R.H. operating environment	10 ppm	100 ppm	1000 ppm	1%	10%
7706 Module:	5 ppm	50 ppm	500 ppm	5000 ppm	5%

- Add 1V when used with plug in modules.
- For RATIO, DCV only. For AVERAGE, DCV and Thermocouples only. Available with plug in modules only.
- Add 6μV to "of range" uncertainty when using Model 7703 and 3μV for Model 7706.
- Auto zero off.
- For LSYNC On, line frequency ±0.1%. For LSYNC Off, use 60dB for ≥ 1PLC.
- For 1kΩ unbalance in LO lead. AC CMRR is 70dB.
- Speeds are for 60Hz (50Hz) operation using factory defaults operating conditions (*RST). Autorange off, Display off, Limits off, Trigger delay = 0.
- Speeds include measurements and binary data transfer out the GPIB.
- Sample count = 1024, auto zero off.
- Auto zero off, NPLC = 0.01.
- Add additional uncertainty of ±0.25% of reading for type J, K, N, T, and E for measurement temperatures <0°C. Add ±0.5°C uncertainty for types R and S <+400°C, and for type B <+1100°C. For Model 7706, add additional uncertainty of ±0.8% of reading for type J, K, N, T, and E for measurement temperatures <0°C. Add ±1°C uncertainty for type R and S <+400°C and type B <+1100°C. Guaranteed by design for types B, E, N, R, and S.
- For lead resistance >0Ω, add the following uncertainty/Ω for measurement temperatures of:

	70°-100°C	100°-150°C
2.2 kΩ (44004)	0.22°C	1.11°C
5.0 kΩ (44007)	0.10°C	0.46°C
10 kΩ (44006)	0.04°C	0.19°C

AC SPECIFICATIONS¹

Function	Range	Resolution	Calibration Cycle	Accuracy: ±(% of reading + % of range), 23°C ± 5°C				
				3 Hz-10 Hz	10 Hz-20 kHz	20 kHz-50 kHz	50 kHz-100 kHz	100 kHz-300 kHz
Voltage²	100.0000 mV	0.1 μV	90 Days	0.35 + 0.03	0.05 + 0.03	0.11 + 0.05	0.6 + 0.08	4.0 + 0.5
	1.000000 V	1.0 μV						
	10.000000 V	10 μV	1 Year	0.35 + 0.03	0.06 + 0.03	0.12 + 0.05	0.6 + 0.08	4.0 + 0.5
	100.000000 V	100 μV						
	750.0000 V	1.0 μV	(Temp. Coeff.)/°C ³	0.035 + .003	0.005 + .003	0.006 + .005	0.01 + .006	0.03 + .01
Current²	1.000000 A	1.0 μA	90 Day/1 Yr.	3 Hz-10 Hz	10 Hz-5 kHz			
	3.000000 A	10 μA		0.30 + 0.04	0.10 + 0.04			
			(Temp. Coeff.)/°C ³	0.35 + 0.06	0.15 + 0.06			
				0.035 + 0.006	0.015 + 0.006			
Frequency⁴ and Period	100 mV	0.333 ppm	90 Day/ 1 Yr.	(3 Hz-500 kHz) (333 ms-2 μs)				
	to	3.33 ppm		100 ppm + 0.333 ppm (SLOW, 1s gate)				
	750 V	33.3 ppm		100 ppm + 3.33 ppm (MED, 100ms gate)				
				100 ppm + 33.3 ppm (FAST, 10ms gate)				

Additional Uncertainty ±(% of reading)

Low Frequency Uncertainty	MED	FAST
20 Hz - 30 Hz	0.3	—
30 Hz - 50 Hz	0	—
50 Hz - 100 Hz	0	1.0
100 Hz - 200 Hz	0	0.18
200 Hz - 300 Hz	0	0.10
>300 Hz	0	0

CREST FACTOR: ⁵	1-2	2-3	3-4	4-5
Additional Uncertainty:	0.05	0.15	0.30	0.40

AC MEASUREMENT CHARACTERISTICS

AC Volts

MEASUREMENT METHOD: AC-coupled, True RMS.

INPUT IMPEDANCE: $1M\Omega \pm 2\%$ // by $<100pF$

INPUT PROTECTION: 1000Vp or 400VDC. 300Vrms with plug in modules.

AC Current

MEASUREMENT METHOD: AC-coupled, True RMS.

SHUNT RESISTANCE: 0.1Ω .

BURDEN VOLTAGE: 1A $<0.3Vrms$, 3A $<1Vrms$. Add 1Vrms when used with plug in modules.

INPUT PROTECTION: 3A, 250V fuse.

Frequency and Period

MEASUREMENT METHOD: Reciprocal Counting technique.

GATE TIME: SLOW 1s, MED 100ms, and FAST 10ms.

AC General

AC CMRR⁶: 70dB.

MAXIMUM CREST FACTOR: 5 at full-scale.

VOLT HERTZ PRODUCT: $\leq 8 \times 10^7$.

AC OPERATING CHARACTERISTICS⁷

60Hz (50Hz) Operation

Function	Digits	Readings/s	Rate	Bandwidth
ACV, ACI	6.5 ⁸	2s/Reading	SLOW	3 Hz-300 kHz
	6.5 ⁸	1.4 (1.1)	MED	30 Hz-300 kHz
	6.5 ⁹	4.8 (4)	MED	30 Hz-300 kHz
	6.5 ⁹	35 (28)	FAST	300 Hz-300 kHz
Frequency,	6.5	1 (1)	SLOW	3 Hz-300 kHz
Period	5.5	9 (9)	MED	30 Hz-300 kHz
	4.5	35 (35)	FAST	300 Hz-300 kHz
	4.5 ¹⁰	65 (65)	FAST	300 Hz-300 kHz

AC System Speeds^{7,11}

RANGE CHANGES¹²: 4/s (3/s).

FUNCTION CHANGES¹²: 4/s (3/s).

AUTORANGE TIME: $< 3s$.

ASCII READINGS TO RS-232 (19.2k baud): 50/s.

MAX. INTERNAL TRIGGER RATE: 300/s.

MAX. EXTERNAL TRIGGER RATE: 250/s.

AC Notes

- 20 % overrange except on 750V and 3A.
- Specification are for SLOW mode and sine wave inputs $>5\%$ of range. SLOW and MED are multi-sample A/D conversions. FAST is DETector:BANDwidth 300 with nPLC = 1.0.
- Applies to 0° - $18^\circ C$ and 28° - $50^\circ C$.
- For square wave inputs $>10\%$ of ACV range, except 100mV range. 100mV range frequency must be $>10Hz$ if input is $<20mV$.
- Applies to non-sine waves $>5Hz$.
- For $1k\Omega$ unbalance in LO lead.
- Speeds are for 60Hz (50Hz) operation using factory defaults operating conditions (*RST). Autorange off, Display off, Limits off, Trigger delay=0. Includes measurement and binary data transfer out GPIB.
- 0.01% of step settling error. Trigger delay = 400ms.
- Trigger delay = 0.
- Sample count = 1024.
- DETector:BANDwidth 300 with nPLC = 0.01.
- Maximum useful limit with trigger delay = 175ms.

Internal Scanner Speeds:

Into and Out of Memory to GPIB¹

7703 Scanning DCV	185/s
7703 Scanning DCV with Limits or Time Stamp On	150/s
7703 Scanning ACV ^{2,3}	155/s
7703 Scanning DCV alternating 2W	60/s
7702 Scanning DCV	60/s
7700 Scanning Temperature (T/C)	55/s
7706 Scanning DCV	50/s

Internal Scanner Speed Notes:

1. Speeds are 60Hz or 50Hz operation using factory default conditions (*RST). NPLC = 0.01. Auto Zero off, Auto Range off, and Display off. Sample count = 1024. Includes measurement and binary data transfer out GPIB.
2. Detector Bandwidth = 300.
3. For Auto Delay On = 1.8/s.

GENERAL SPECIFICATIONS:

POWER SUPPLY: 100V / 120V / 220V / 240V \pm 10%.

LINE FREQUENCY: 45Hz to 66Hz and 360Hz to 440Hz, automatically sensed at power-up.

POWER CONSUMPTION: 28VA.

OPERATING ENVIRONMENT: Specified for 0°C to 50°C. Specified to 80% RH at 35°C.

STORAGE ENVIRONMENT: -40°C to 70°C.

BATTERY: Lithium battery-backed memory, 3 years @ 23°C.

WARRANTY: 3 years.

EMC: Conforms to European Union Directive 89/336/EEC EN61326-1.

SAFETY: Conforms to European Union Directive 73/23/EEC EN61010-1, CAT I.

VIBRATION: MIL-PRF-28800F Class 3, Random.

WARM-UP: 2 hours to rated accuracy.

DIMENSIONS:

Rack Mounting: 89mm high \times 213mm wide \times 370mm deep (3.5 in \times 8.375 in \times 14.563 in).

Bench Configuration (with handle and feet): 104mm high \times 238mm wide \times 370mm deep (4.125 in \times 9.375 in \times 14.563 in).

SHIPPING WEIGHT: 6.5kg (14 lbs.).

DIGITAL I/O: 2 inputs, 1 for triggering and 1 for hardware interlock. 5 outputs, 4 for Reading Limits and 1 for Master Limit. Outputs are TTL compatible or can sink 250mA, diode clamped to 33V.

TRIGGERING AND MEMORY:

Window Filter Sensitivity: 0.01%, 0.1 %, 1%, 10%, or Full-scale of range (none).

Reading Hold Sensitivity: 0.01%, 0.1 %, 1%, or 10% of reading.

Trigger Delay: 0 to 99 hrs (1ms step size).

External Trigger Delay: <2ms.

External Trigger Jitter: <1ms.

Memory Size: 55,000 readings.

MATH FUNCTIONS: Rel, Min/Max/Average/Std Dev/Peak-to-Peak (of stored reading), Limit Test, %, and mX + b with user defined units displayed.

REMOTE INTERFACE:

Keithley XLinux Up & Running starter software

GPIB (IEEE-488.2) and RS-232C.

SCPI (Standard Commands for Programmable Instruments)

LabVIEW Drivers

TestPoint Drivers

ACCESSORIES SUPPLIED: Model 1751 Safety Test Leads, User Manual, Service Manual.

7706 All-in-One I/O Module

GENERAL

20 CHANNELS: 20 channels of 2-pole relay input.
All channels configurable to 4-pole.

RELAY TYPE: Latching electromechanical.

ACTUATION TIME: <3ms.

CAPABILITIES

CHANNELS 1-20: Multiplex one of 20 2-pole or one of 10 4-pole signals into DMM.

Channels 21-25 are referenced to chassis ground.

CHANNELS 21-22: 16 Digital Outputs.

CHANNELS 23-24: Analog Voltage Output (2).

CHANNELS 25: Totalize Input.

INPUTS (Channels 1-20)

MAXIMUM SIGNAL LEVEL (Channels 1-20): 300V DC or rms, 1A switched, 60W, 125VA maximum.

SAFETY CATEGORY: CAT I.

CONTACT LIFE (typ.): >10⁶ operations at max. signal level: >10⁶ operations cold switching.

CONTACT RESISTANCE: <1Ω at end of contact life.

CONTACT POTENTIAL: <±2μV typical per contact pair, 3μV max.

OFFSET CURRENT: <100pA.

CONNECTOR TYPE: Screw terminal, #22 AWG wire size.

ISOLATION BETWEEN ANY TWO TERMINALS: >10⁹Ω, <100pF with isolation channels 27 and 28 open.

ISOLATION BETWEEN ANY TERMINAL AND EARTH: > 10⁹Ω, <200pF.

CROSS TALK (10MHz, 50Ω Load): <-35dB.

INSERTION LOSS (50Ω Source, 50Ω Load): <0.1dB below 1MHz. <3dB below 2MHz.

COMMON MODE VOLTAGE: 300V between any terminal and chassis.

DIGITAL OUTPUT (Channels 21 and 22)

V_{out(L)}: <0.8V @ I_{out} = 400mA.

V_{out(H)}: >2.4V @ I_{out} = 1mA.

V_{out(H)MAX}: <42V with external open drain pull-up.

WRITE SPEED: 50/s.

ANALOG VOLTAGE OUTPUT (Channels 23 and 24)

DAC 1, 2: ±12V, non-isolated.

RESOLUTION: 1mV.

I_{out}: 5mA max.

SETTLING TIME: 1ms to 0.01% of output.

ACCURACY ±(% of output + mV):
Measured with ≥10MΩ input resistance DMM.
1 year ±5°C: 0.15% + 19mV;
90 day ±5°C: 0.1% + 19mV;
24 hour ±1°C: 0.04% + 19mV.

TEMPERATURE COEFFICIENT: ±(0.015% + 1mV)/°C.

WRITE SPEED: 50/s.

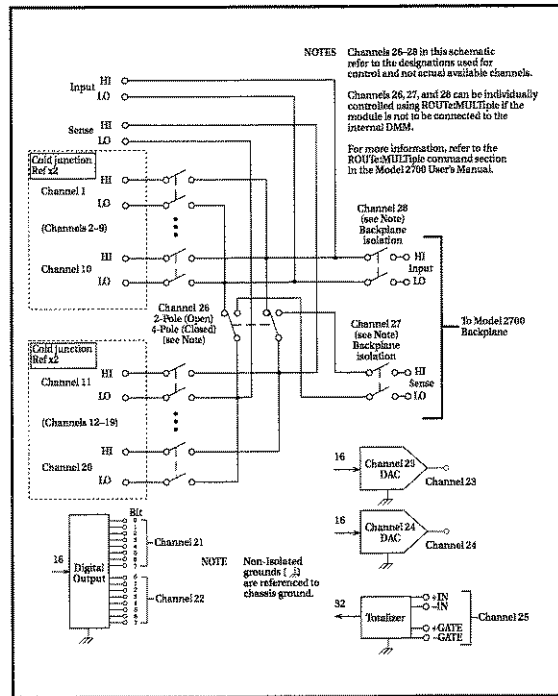

TOTALIZE INPUT (Channel 25)

MAXIMUM COUNT: 2³²-1.

TOTALIZE INPUT: 100kHz (max), rising or falling edge, programmable.

SIGNAL LEVEL: 1Vp-p (min), 42Vpk (max).

THRESHOLD: 0V or TTL, jumper selectable.

DATE INPUT: TTL-Hi, TTL-Lo, or none.

COUNT RESET: manual or Read+Reset.

READ SPEED: 50/s.

ENVIRONMENTAL

Specified for Model 2700, firmware revision A02 or later.

OPERATING ENVIRONMENT: Specified for 0°C to 50°C.
Specified to 80% R.H. at 35°C.

STORAGE ENVIRONMENT: -25°C to 65°C.

WEIGHT: 0.5kg (1.1 lbs).

All specifications subject to change without notice.

