

PHILIPS

Manual

**TRANSISTOR CURVE-TRACER
PM 6507**

9452 065 07..1

9499 520 04511

1/469/1/04

CONTENTS

GENERAL

I. INTRODUCTION	7
II. WORKING PRINCIPLE	7
III. BLOCK DIAGRAM	8
1. Control section	8
2. Display section	12
IV. TECHNICAL DATA	13
V. ACCESSORIES	15

DIRECTIONS FOR USE

VI. INSTALLATION	17
A. Adjustment to the local mains voltage	17
B. Earthing	17
C. Connection to the mains	17
D. Rack mounting version	18
VII. OPERATING INSTRUCTIONS	19
A. Survey of the controls	19
B. Hints for testing semi-conductors	19
C. Functions of the controls	19
D. Operation	23
1. Basic setting	23
2. Switching-on the apparatus	23
3. Connection of a semi-conductor	23
4. Adjusting the display section	23
5. Setting for testing semi-conductors with 3 or 4 terminals	23
6. Setting for breakdown tests of diodes and other elements with 2 connections	26
7. Setting for external control or programming	27

SERVICE DATA

VIII. CIRCUIT DESCRIPTION	37
A. Supply section	37
1. Mains supply	37
2. Collector voltage supply	37
3. H.T. supply	37
4. Direct voltage source $+31.5/+30/0/-30$ V	37
B. Step generator	39
1. Phase shifter, amplifier and rectifier, pulse shaper	39
2. Duty cycle	39
3. Ring counter	39
4. Amplifier	43
5. Power amplifier	44
C. Display section	44
1. Circuit for I_C and V_{CE} measurements	45
2. Circuit for V_{BE} measurements	46
3. Circuit for breakdown voltage and leakage current measurements	47
4. Difference amplifier for X and Y-deflection	48
5. Output amplifiers for X and Y-deflection	48
6. Brightness control	48
IX. DISASSEMBLY	49
A. Cabinet	49
B. C.R.T.	49

	3
C. Removing the subunits	52
D. Removing components	57
X. MAINTENANCE	61
XI. SURVEY OF ADJUSTING ELEMENTS	62
XII. CHECKING AND ADJUSTING	63
A. Direct voltages +30 V and —30 V	63
B. EHT unit 4.5 kV	64
C. 3 kV voltage for testing diodes	64
D. Step generator	64
E. Collector voltage supply	64
F. Monitor	65
XIII. THE SHIPMENT OF THE INSTRUMENT	67
XIV. LISTS OF PARTS	68

LIST OF FIGURES

1	Basic construction	6
2	Block diagram	10
3	Accessories	15
4	Rear side of the instrument	17
5	Making the instrument suitable for a 19" rack	18
6	} Basic considerations for testing semi-conductors	19
7		
8		
9	Front view with controls and sockets	20
10	Trigger point	20
11	Effect of the duty-cycle control	24
12	Curve display with current limiting	24
13	Breakdown characteristics	25
14	Compensation for the non-linear part of the base-emitter diode characteristic	25
15	I_D - V_{DS} -characteristic of an N-channel junction FET	26
16	I_D - V_{DS} -characteristic of a P-channel enhancement-type MOS-FET	26
17	Position of the screen over the semi-conductor under test	27
18	Display in positions α and C of PM 6546	27
19	Circuit for external programming	28
20 ... 47	Various measurements with the curve tracer	29 ... 35
48	Supply part	36
49	Collector-voltage source	36
50	H.T.-source	36
51	Step-voltage generator	38
52	Trigger circuit (U9)	38
53	Principle of the ring counter	40
54	Voltage-divider circuit	40
55a	Switch position REP FAM	40
55b	Switch position SINGLE FAM	41
55c	Switch position ONE CURVE	42
56	Amplifier	43
57	Voltage drive	44
58	Collector-current circuit	45
59	Measuring circuit for V_{BE} measurement	46
60	Measuring circuit for breakdown-voltage and leakage-current measurements	47
61	X-Power amplifier	49
62	Side view (left)	50
63	Top view	51
64	Bottom view	52
65	H.T. unit U2 (supply for C.R.T.), taken off	53
66	X-Deflection unit U3, taken off	53
67	Y-Deflection unit U4, taken off	54
68	Base-resistor unit U5, taken off	54
69	Shunt unit U6, taken off	55
70	Final-amplifier unit U8, taken off	55
71	Side view right	56
72	Step generator U9, taken off	57
73	Rear view (rear panel taken off)	58
74	Collector-load unit U10, taken off	58
75	H.T. unit U11 (3 kV), taken off	59
76	Socket unit U12, taken off	60
77	Push-button unit U15 and SK4, taken off	60
78	Adjusting the zener diodes	63
79	Adjusting the collector-voltage source 0-10 V	65
80	Hum influence on the C.R.T.	65
81	Adjusting the X-deflection	67
82	Adjusting the Y-deflection	67
83	Front view with item numbers	69
84	Rear view with item numbers	69
85	Side view (left) with item numbers	70
86	PM 6546 with item numbers	70

87	Diagram PM 6546	81
88	Printed wiring board PM 6546	81
89	Switch wafers SK2	82
90	Switch wafers SK10	82
91	Switch wafers SK12	82
92	Switch wafers SK13	82
93	Switch wafers SK16	83
94	Connection diagram for mains transformer T2	83
95	Connection diagram for collector transformers T3 and T4	83
96	Connection diagram for H.T. transformer T201	83
97	Connection diagram for H.T. transformer T1101	83
98	Printed wiring board U1, final amplifier	84
99	Printed wiring board U2, H.T. circuit	85
100	Printed wiring board U3A, pre-amplifier	86
101	Printed wiring board U3B, X-deflection	87
102	Printed wiring board U3C, X-deflection	88
103	Printed-wiring board U4A, pre-amplifier	89
104	Printed wiring board U4B, Y-deflection	90
105	Printed wiring board U4C, Y-deflection	91
106	Printed wiring board U5A, base resistors	92
107	Printed wiring board U6A, shunt plate	93
108	Printed wiring board U7, power supply	94
109	Printed wiring board U8A, final amplifier	95
110	Printed wiring board U9A, step generator	96
111	Printed wiring board U9B, ring counter	97
112	Printed wiring board U11A, high-tension unit	98
113	Printed wiring board U13, adjusting circuit	99
114	Circuit diagram of the intensity limiter	100
115	Circuit diagram	103

IMPORTANT

In correspondence concerning this apparatus, please quote the type number and serial number as given on the plate at the back of the apparatus.

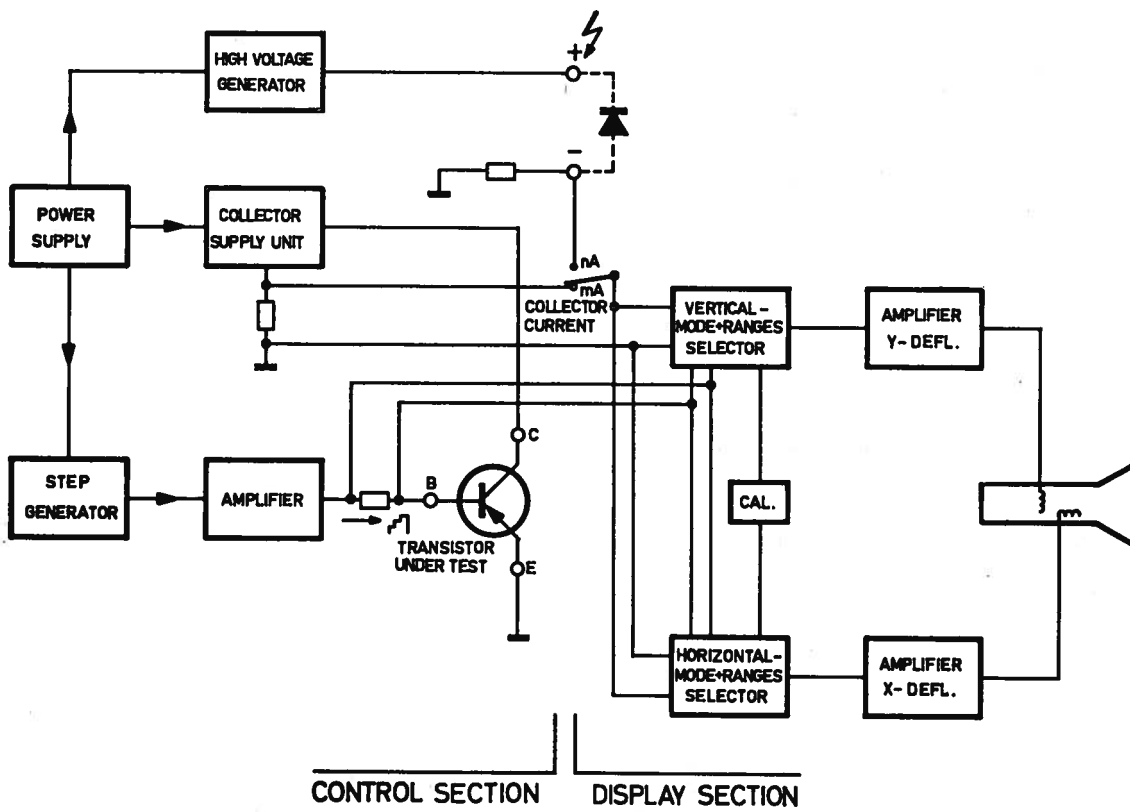

Fig. 1. Basic construction

GENERAL

I. Introduction

The PHILIPS Curve-tracer PM 6507 is a universal instrument for measuring and determining the characteristics of transistors and diodes. On the square flat c.r.t. it is possible to display single curves as well as sets of curves (up to 8) in various modes. The switchable duty-cycle control circuit permits of displaying characteristics of power transistors up to their limits, without subjecting these transistors to thermal overload.

The current and voltage sources for supplying the semi-conductors under test have a very wide range (I_C max. 20 A, V_{CE} max. 500 V).

For testing the breakdown characteristics of diodes a separate H.T. source (max. 3000 V) is available.

Due to its special circuitry the curve tracer can satisfy the high standards set in semi-conductor measuring techniques.

It is therefore extremely suitable for being used in laboratories, but may also serve as a test apparatus for selecting and comparing semi-conductors with certain properties.

II. Working principle

The simplified diagram of Fig. 1 shows the basic construction of the PM 6507. From this diagram it appears that the apparatus essentially consists of 2 sections, namely:

- the supply and control section, and
 - the display section with the c.r.t.
- The supply and control section comprise all control elements required for setting the desired mode of operation and adjusting the unit to the operating data of the semi-conductor under test. For testing a transistor these are the collector and base supply voltages. For the collector circuit a half-wave voltage source of maximum 500 V is available. This voltage has been divided into four ranges, which can be selected by means of push-buttons, and is continuously adjustable within these ranges. The base circuit is driven by the step generator.

Dependent on the repetition frequency and the step value selected, a base signal is obtained which has the shape of a step curve. This will give rise to current and voltage variations in the collector circuit of the transistor under test which correspond to the properties of this transistor.

- The relevant data are applied to the display section and displayed on the c.r.t. It is possible to select a display method for the curve or set of curves which is in accordance with the operating mode of the transistor. The horizontal and vertical deflection amplifiers can be adjusted to optimum resolution over a wide range so that accurate and clear measurements can be made.

For testing diodes in the breakdown region the apparatus has been provided with a separate HT generator which can supply voltages up to 3 kV.

III. Block diagram

The block diagram (Fig. 2) gives a survey of the arrangement of the various circuits. In order to obtain a better understanding of the switching functions the relevant switches are shown in the appertaining units in a simplified form. This has only been done in order to explain the general principle and not to explain the individual units.

A mains transformer which can be adapted to 2 voltage ranges delivers the various voltages required for supplying the apparatus. The collector supply unit serves for supplying the collector circuit. The voltage ranges which can be pre-selected in 4 steps by means of push-buttons can be adjusted to any intermediate value by means of a variable transformer.

Selection of the polarity of the supply voltage is effected by means of push-button PNP-NPN. It is moreover possible to include 20 different resistors with values from 0...100 k Ω in the collector circuit: these resistors serve for current limiting and protect the semi-conductor under test against overload.

The above-mentioned variable transformer also serves to adjust the high tension for testing diodes in the breakdown region, whereby the voltage can be increased continuously up to 3 kV. For measuring leakage currents seven μ A and ten nA ranges are available.

1. Control section

a. Step generator

The step generator produces the step voltage for supplying the base circuit. From a winding of the mains transformer two trigger frequencies of 100 Hz which are shifted 90° with respect to each other are taken and rectified. By means of slide switch "CURVES/sec" either or both voltages are applied to the pulse shaper. This shaper delivers short needle pulses which drive the ring counter by means of which the step voltage is obtained, and moreover trigger a monostable multivibrator. The duty cycle of this multivibrator can be adjusted by means of control "DUTY CYCLE". During the pulse cycle of the multivibrator the step voltage of each individual stage is applied to the differential amplifier. As soon as the multivibrator changes over, the step voltage is short-circuited so that interrupted steps are obtained. When control "DUTY CYCLE" is at 100 % the multivibrator is inoperative. The steps then appear without interruption. Dependent on the selected pulse frequency and duty cycle either the beginning or end of the curve can be displayed or both the beginning and end. This method has the advantage that the semi-conductor under test is only loaded during the phase displayed so that it is possible to write the characteristics at the maximum power ratings without the risk of thermal overloading. The differential amplifier serves to accurately maintain the preset operating data of the base circuit and to correct these by means of reference values. For this purpose the operating currents or voltages on the semi-conductor under test are applied to the differential amplifier via an impedance transformer, which via the power amplifier keeps the output amplitude at the nominal value.

The polarity of the step signal (and consequently of the collector voltage) can be preset by means of a push-button (PNP-NPN). Voltage V_{BE} only can also be preset for normal and inverse operation. Another push-button serves for selecting common emitter or common base arrangement.

For adjusting the exact zero point of the step curve datum line control "ZERO" is employed. By means of this control the lower curve (i.e. base current 0) is adjusted to the value of the leakage current. Thus a proper curve display is obtained which is based on the leakage current.

The step current and voltage ranges are selected by switching in resistors. When the base circuit is supplied with a constant voltage series resistors of 0...10 M Ω can be included.

This additional resistance provides matching of the voltage generator and limits the current through the base-emitter circuit. Depending on the position of slide switch "TRANSISTOR INPUT" the input of the semi-conductor under test is driven (DRIVEN), grounded (GROUNDED) or open-circuited (OPEN).

b. Collector voltage supply

The collector voltage is adjusted by means of a continuously variable transformer. The two following transformers in push-pull arrangement have 4 voltage ranges, which can be selected by means of push-buttons. The control range then covers the relevant voltage range of the selected stage and the output voltage is full-wave rectified.

The pulsating d.c. voltage should not be smoothed in order to permit full deflection of the adjusted collector voltage from zero to maximum. The polarity of this voltage can be reversed by means of push-button switch PNP-NPN. Resistors of 0...100 k Ω can be included in the current circuit in steps for current limitation (LOAD).

The current as well as the voltage are determined in resistance dividers. In this way the measuring conditions are independent of each other for all ranges.

c. Connection of the semi-conductor under test.

Two-transistor holders (and socket connectors) TS1 and TS2 serve for connection of the semi-conductor under test. By means of the switch either TS1 or TS2 can be connected; in the centre position both transistors are disconnected.

Connection strip TS1 has been provided with coaxial double-sockets (Kelvin take-offs). Consequently the measuring result is not influenced by the voltage drop over the supply lead to the semi-conductor under test.

d. Additional supply sources

1. Diode voltage source

For testing semi-conductors or other 2-pole elements the apparatus has been provided with a half-wave H.T. voltage source. This voltage source is also continuously adjustable from 0 to 3 kV by means of the variable transformer. The voltage-current characteristic is displayed on the c.r.t.,

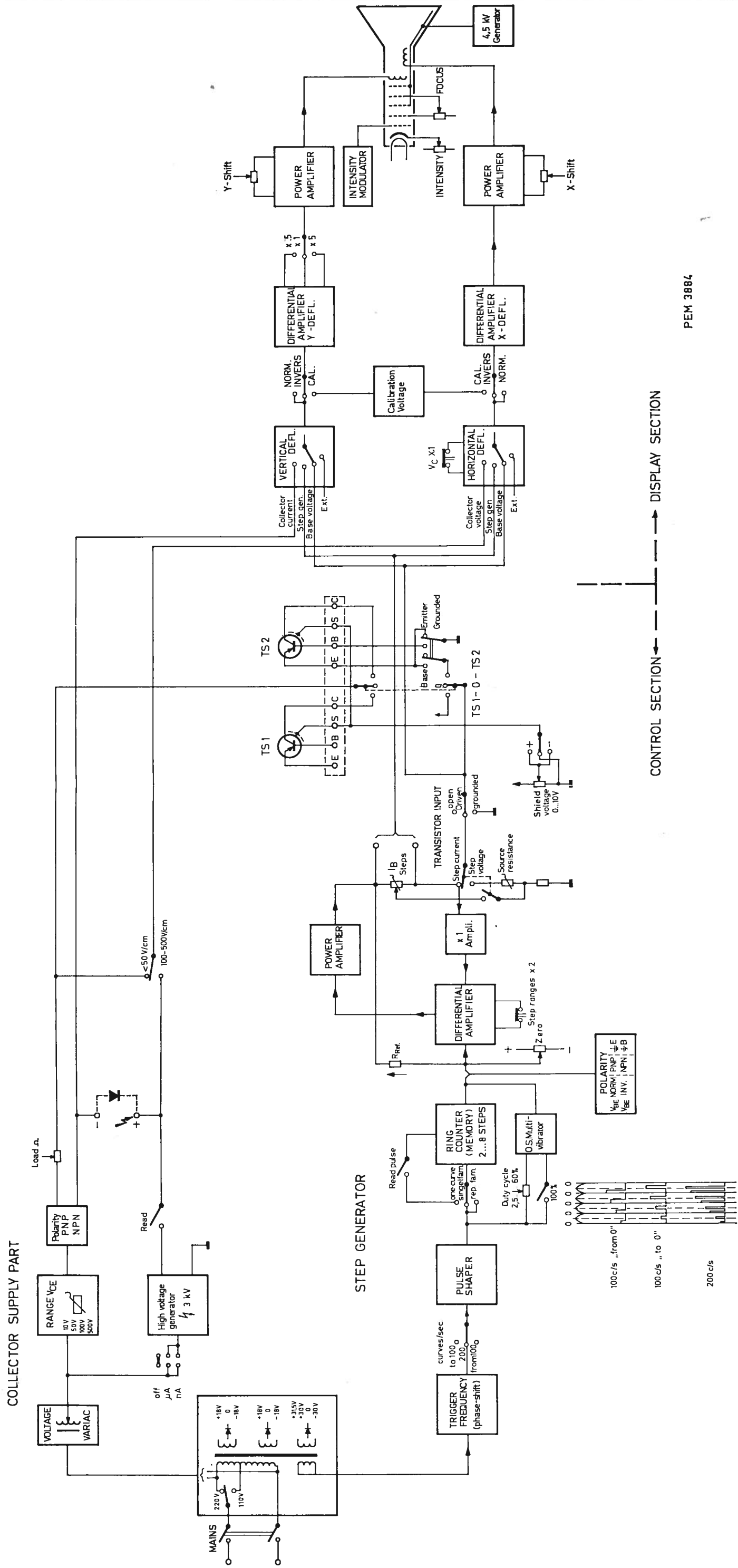

CONTROL SECTION ← → DISPLAY SECTION

PEM 3884

Fig. 2. Block diagram

whereby 3 voltage measuring ranges are available which can be reduced by a factor 10 with push-button x.1, as well as several switchable ranges for μA and nA measurements.

Push-button "Read" connects the H.T. circuit only when it is closed manually or by means of a protection device.

2. Voltage source for fourth electrode

Connection socket "S" on the transistor holder, apart from earthing the transistor case (e.g. with H.F. transistors), may also serve for connecting e.g. a second gate in case of field effect transistors. For this a variable direct voltage of max. 10 V can be applied (Shield Voltage), whose polarity can be selected by means of a switch.

2. Display section

The display section of the curve tracer does not affect the working of the other sections. After having passed the relevant circuits and after being amplified the voltage or current changes occurring in the transistor are displayed on the c.r.t.

Two step-switches serve for range selection and mode selection for the horizontal and vertical deflection.

The horizontal deflection comprises 12 collector voltage ranges, 4 base voltage measuring ranges, one step range position, 3 ranges for diode test voltages and position "EXT" for external control.

By means of the step switch for the vertical deflection the collector current range is selected in 18 steps, whereby the sensitivity of 10 steps can be increased

by a factor 10^3 for measuring diode leakage currents. Moreover, the base voltage measuring sensitivity can be adjusted in 4 steps by means of this switch and an additional position is available for external control. By means of a slide switch all vertical deflection ranges can be extended to either side by a factor 0.5 and 5. To enable proper curve display in case of an inverted signal, a switch has been provided by means of which the polarity of the horizontal and vertical deflection voltages can be reversed.

This switch also serves for switching on the calibration voltage ("CAL").

The voltages present on the semi-conductor (or the current relations) are not influenced by the display section.

Therefore the operating voltages for the semi-conductor under test are applied to the differential amplifiers via high-ohmic input stages. The output amplifiers supply the power required for the magnetic deflection, whereby the trace can be shifted in the horizontal and the vertical direction by means of the combined coarse and fine controls.

The acceleration voltage for the picture tube is delivered by a 4.5 kV generator.

In order to keep the brightness of the picture constant at different sweep speeds a brightness modulator has been provided which increases the intensity at the higher speeds.

The brightness of the picture is also influenced by control "Duty Cycle".

IV. Technical data

Tolerances: Numerical values with statement of tolerances are guaranteed by the factory. Data without tolerances serve merely for information and represent the properties of an average apparatus.

Step generator

Step current generator:

- Current steps (constant current values) : 1, 2, 5 μ A etc . . . 200 mA/step
(17 steps plus a 0 - step)
All current steps can be doubled for a brief period
- Number of curves : 7 (8 with datum line) adjustable from 2 . . . 8
- Stability of the step spacings : Between the first and seventh step within an arbitrary range < 1 %; with respect to each other: in all ranges < 3 %
- Stability of the current generator : A load variation of 0.1 V at 1 V causes an error of < 1 % in all ranges

Step voltage generator:

Voltage steps mV/step	0	20	50	100	200	500	1000
max. internal resistance Ω : (current per step 200 mA)	0.1	0.1	0.25	.5	1	2.5	5

All voltage steps can be doubled for a brief period

Switchable source resistors

- : steps: 0, 1, 2, 5 Ω etc . . . 10 M Ω (23 steps)

Duty cycle

- : at 100 pulses/sec. 250 μ s . . . 6 ms
(2.5 % . . . 60 % and 100 %
at 200 pulses/sec. the same pulse times apply, however, twice the duty cycle in percentages. Overlap from 4 ms.

Zero adjustment of the step voltage

- : Can be shifted 100 % (7 steps) in the positive or negative direction
(at 200 mA/step and all mV/step ranges max. 12 V at 30 % duty cycle).

Collector supply

Rectified sine-wave voltage, continuously adjustable in 4 ranges

Voltage range	Max. current	Internal resistance R_i (at 220 V)
0 . . . 10 V_{p-p}	20 A	0.3 Ω
0 . . . 50 V_{p-p}	4 A	3.8 Ω
0 . . . 100 V_{p-p}	2 A	16 Ω
0 . . . 500 V_{p-p}	0.2 A	400 Ω

Polarity

- : Reversible by means of button PNP-NPN

Overload protection

- : By means of thermo-magnetic switch.
Response time at 2x the nominal current:
approx. 15 secs.
Response time at 10x nominal current:
0.05 secs. at max.

Current limitation

- : By means of switchable series resistors.
Resistance scale:
0, 0.1, 0.2, 0.5 Ω etc . . . 100 k Ω \pm 10 % (20 steps)

Connection sockets BU2B

- : provided with Kelvin take-offs when adapter PM6549A is used.

Diode voltage source

Voltage range

- : (continuously adjustable half-wave voltage)
0 . . . 3000 V_{p-p}

Maximum load current

- : 1 mA

Short circuit current

- : 8 mA $_{p-p}$ at max.

Internal resistance

- : 370 k Ω

Voltage source for 4th electrode

- : 0 . . . 10 V; continuously adjustable from 0 to + or -10 V
Connection to the "S" socket

Display section

C.r.t.	: Type AW 17/69, flat screen 10 x 12 cm magnetic deflection, electrical focussing. 4.5 kV acceleration voltage
Beam current intensity	: Externally adjustable, moreover automatic brightness modulation depending on duty cycle and sweep speed.
Lattice illumination	: continuously adjustable
Y-deflection	: Collector current : 10 - 20 - 50 μ A/cm ... 5 A/cm (18 steps) Diode current : 10 - 20 - 50 nA/cm ... 10 μ A/cm (10 steps) Step function : 1 step/cm (step adjustment according to "step selector") V_{BE} ranges : 20 - 50 - 100 - 200 mV/cm
Expansion switch	: All deflection ranges can be extended by a factor .5 or 5. External deflection coefficient: 10 mV/cm (5 mV or 50 mV/cm) Polarity of the deflection: reversible Shift range: 10 times the screen height with coarse-fine control
X-deflection	: Collector voltage : 10 - 20 - 50 mV/cm ... 50 V/cm (12 steps) Diode voltage : 100 - 200 - 500 V/cm 10 times reduction possible with switch x.1 Step function : 1 step/cm (step adjustment according to "step selector") V_{BE} ranges : 10 - 20 - 50 - 100 mV/cm External deflection coefficient: 10 mV/cm Deflection polarity : reversible Shift range : 10 times screen width with coarse fine control
External input	: Symmetrical : 10 mV/cm Input resistance *) : 1,000 m Ω , at Y2/X1/X2 internally shunted with 1 M Ω Drive voltage : max. 1 V_{p-p} Maximum permissible input voltage: 100 V d.c. (short-term) Maximum permissible common mode voltage: $\pm 8 V_{p-p}$
External connection facility for	: Z-modulation Datum line adjustment External step signal programming Auxiliary voltage: ± 30 V
Calibration	: Calibration voltage: 50 mV ± 0.5 % causing a deflection of 5 cm (horizontal and vertical)
Mains supply	
Mains voltages	: 115 V and 230 V ± 15 % Frequency: 40 ... 60 Hz; also suited for 400 Hz
Power consumption	: approx. 50 VA at normal load approx. 250 VA at max. load
Inaccuracy	: Measuring resistors < 1 % Indication: < 3 % for a field of 8x10 cm
Ambient temperature	+10° ... +35°C without any adverse effect -10° ... +50°C additional error of ± 2 % -20° ... +60°C operational at reduced power
Mechanical data	
	: Dimensions : Height 22 cm Width 45 cm Depth 32 cm Weight : 21 kg

* The M Ω shunt resistors (R362, R363, R426) can be removed.

V. Accessories

- 1 Mains cable
- 2 Transistor adapters PM 6549 (for L.F. and power transistors)
- 1 Manual

Optional accessories:

- Transistor adapter PM 6544 for power transistors (case SOT9; DIN 9A2)
- Transistor adapter PM 6547 (for RF transistors)
- Transistor adapter PM 6548 (empty case for mounting special holders)
- Transistor adapter PM 6549A (for power transistors, with Kelvin take-offs)
- Diode adapter PM 6546
- Polaroid camera
assy PM 9380
- Camera adapter PM 9377
- Supplementary
Cense PM 9373



PM 6547



PM 6548



PM 6549



PM 6546



PM 6544



PM 6549A

Fig. 3. Accessories



DIRECTIONS FOR USE

VI. Installation

A. ADJUSTMENT TO THE LOCAL MAINS VOLTAGE

At the rear of the apparatus (Fig. 3) a voltage adapter has been fitted by means of which the apparatus can be adjusted to the local mains voltage. The apparatus can be adapted to 2 mains voltages, i.e. $115\text{ V} \pm 15\%$ and $230\text{ V} \pm 15\%$.

Fuses VL1 and VL2: for 230 V:1 A (delayed action type)
for 115 V:2 A (delayed action type)

The 2A-fuses are situated in the two holders shown in fig. 4.

B. EARTHING

The apparatus should be earthed in accordance with the local safety regulations.

This may be effected:

- Via the accessory 3-core mains cable, provided that this is connected to a mains socket with rim earthing.
- Via the earthing screw at the rear of the apparatus.

C. CONNECTION TO THE MAINS

- Before connecting the unit check that the voltage adapter is set to the correct position.
- Connect the apparatus to the mains (check earthing) and switch it on by means of mains switch "POWER"
- The pilot lamp above the switch should light up.

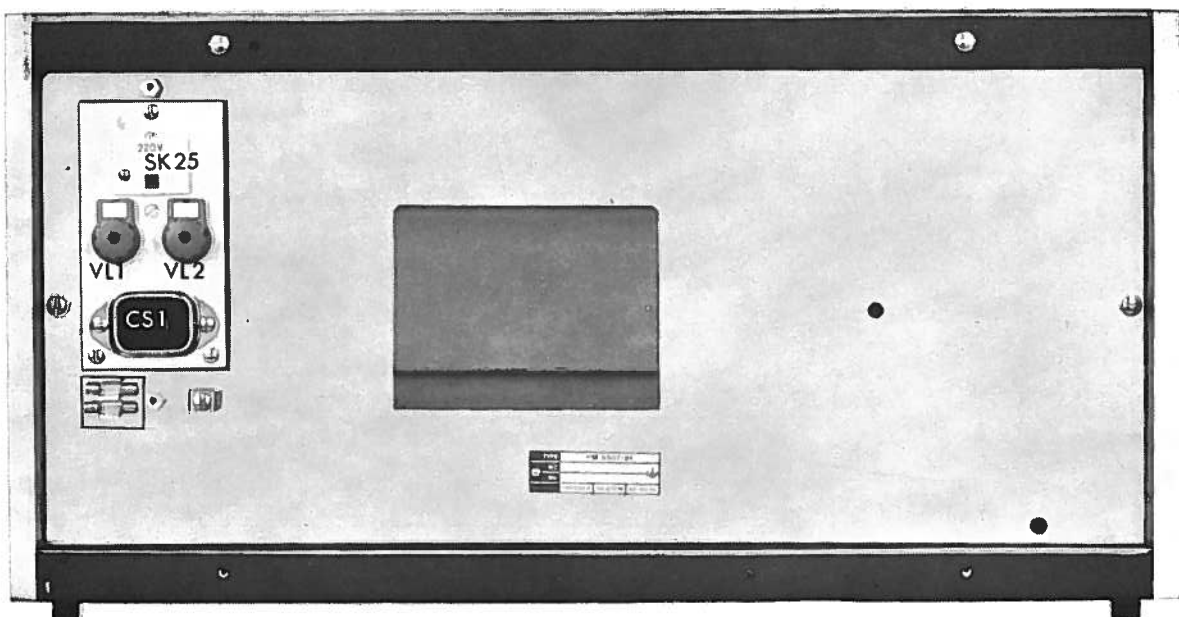

Fig. 4. Rear side of the instrument

D. RACK-MOUNTING VERSION

The dimensions of the transistor curve tracer permit of mounting the instrument into a 19" rack. For this purpose a cornerpiece should be fitted on each side. These pieces are already present in the instrument.

For converting the instrument proceed as follows:

- Remove the two side plates (4 screws each).
- Remove the 4 feet.
- The cornerpieces have been mounted on each side by means of 2 screws "A" (Fig. 5). Remove these

screws, take out the cornerpieces and refit the screws.

- Remove the frontmost screws "B" and fit the cornerpieces by means of these screws.
- Refit the side plates.

When mounting the instrument ensure that the air circulation is not impeded. Especially make sure that the instrument is not placed close to an apparatus giving off much heat (observe max. ambient temperature!).

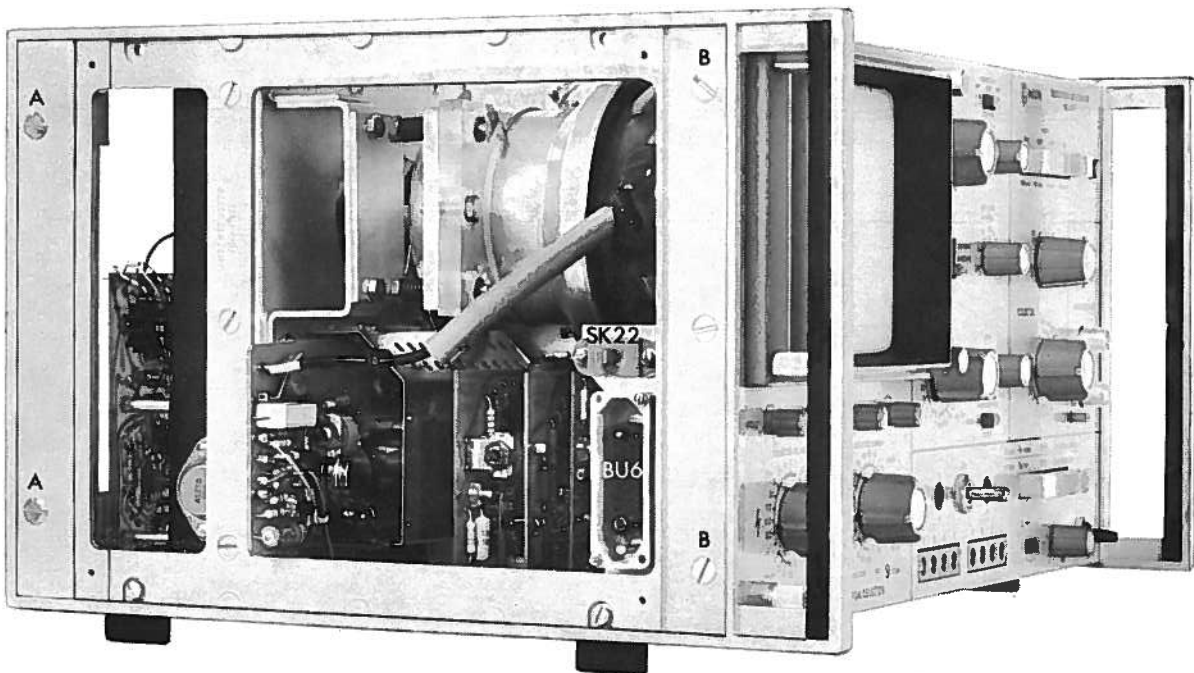

Fig. 5. Making the instrument suitable for a 19" rack

VII. Operating instructions

ATTENTION:

The collector supply source permits adjustment of voltages up to $500 V_{\text{peak}}$ with respect to earth.

At the high tension output this is even as high as $3000 V_{\text{peak}}$ with respect to earth.

Voltages exceeding $34 V_{\text{peak}}$ may be lethal. When inserting the semi-conductor under test into the sockets or adapter, switch SK18 should always be in position "OFF"! The semi-conductor connection is then interrupted at three points.

The utmost of care should be taken when working with high supply voltages.

For testing diodes with the aid of the high-tension source, it is advisable to use the special adapter PM 6546, described in this manual.

A. SURVEY OF THE CONTROLS see Fig. 9

B. HINTS FOR TESTING SEMI-CONDUCTORS

In practice it often appears that certain problems in measuring semi-conductors are due to misjudgement of the semi-conductor under test. In this chapter the most essential points are given which must be observed when testing a semi-conductor.

First consideration: To which type belongs the semi-conductor to be tested?

Diode - Thyristor - PNP - or NPN transistor, Power, R.F. or L.F. transistor, Field effect transistor, etc.

Before connecting the transistor or diode to be tested it is necessary to establish type and power rating.

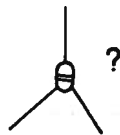

Fig. 6

Second consideration: What points should be checked? Short-circuit, leakage current, breakdown voltage, current gain, characteristics of a certain function etc.

The best method is to effect the measurement according to a definite testing procedure, especially with types whose characteristics are not known and which consequently may show deviations from the pre-set values.

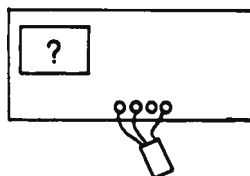

Fig. 7

Third consideration: Which is the max. power limit of the semi-conductor under test; which are the maximum permissible voltages and currents?

This point is very important, because especially in testing semi-conductors it may occur that the maximum permissible values are exceeded and the semi-conductor under test is damaged. In this respect, however, the curve tracer offers the possibility to display the characteristics at extreme values without overloading the semi-conductor. The relevant instructions are given under point D 5.1.1-5.

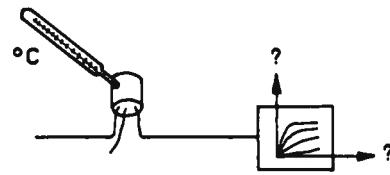

Fig. 8 Basic considerations for testing semi-conductors

C. FUNCTIONS OF THE CONTROLS

The indications of the controls refer to Fig. 9.

SK1: CURVES/sec. 100 from 0 - 200 - 100 to 0.

This slide switch serves for adjusting the step frequency (100 or 200 Hz) and selection of the trigger point at 100 Hz.

For explaining the indications 100 from 0 and 100 to 0 the working of the step generator should be described a bit further.

For obtaining a step signal a voltage stepped from 0 to a certain maximum value is required at regular intervals.

From the maximum value the voltage drops again to 0 and the cycle is repeated. The step circuits are triggered by means of a 100 Hz \square -signal. There are two trigger points, one of which lies at the maximum values of the half-wave and the other one at the 0 point (Fig. 10).

These two trigger points determine the starting level of the step voltage whereby the pulse width can be adjusted from 2.5...60% and 100% by means of control "DUTY CYCLE". This makes it possible to display either the first or the last part of a characteristic, or both when the curve tracer is set accordingly. This facility has the advantage that the semi-conductor can be tested at low power dissipation when a display of the characteristics at the extreme values is required.

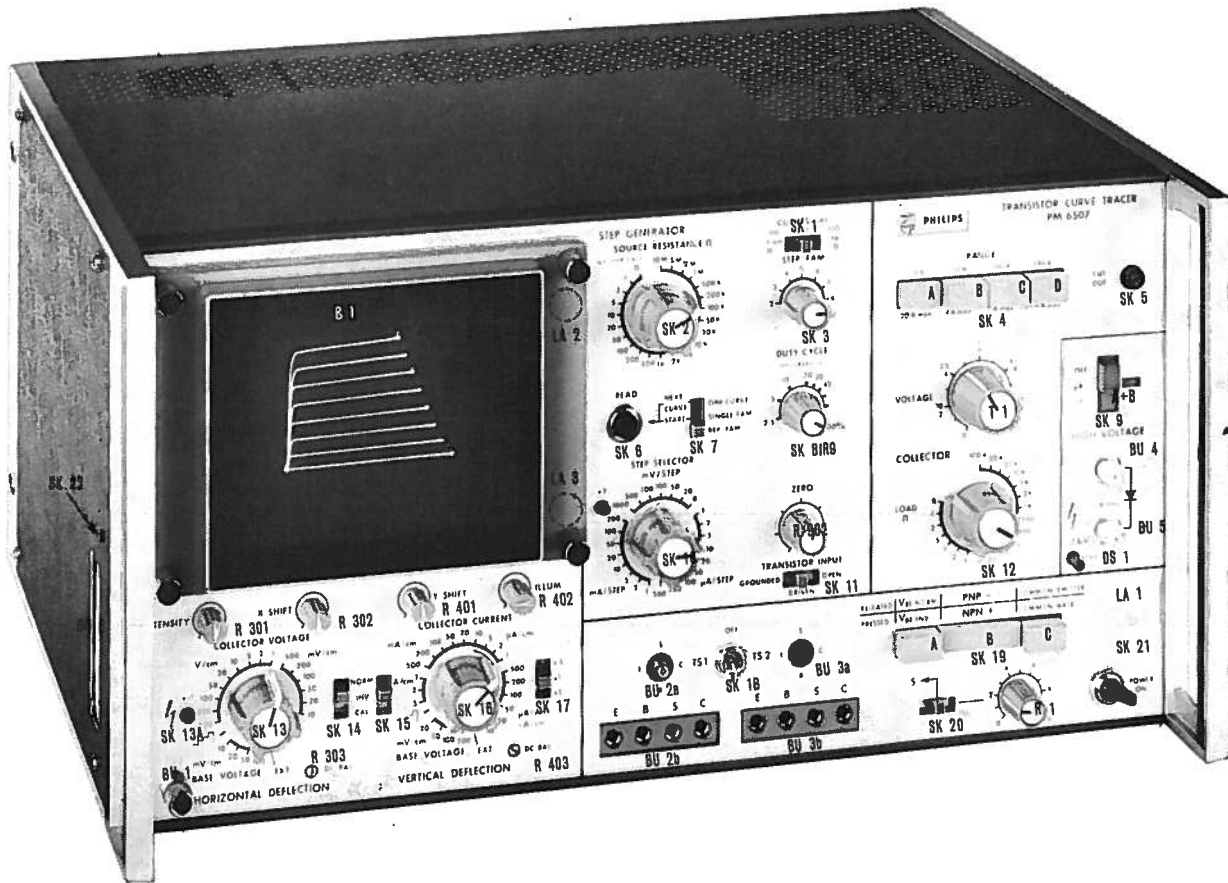
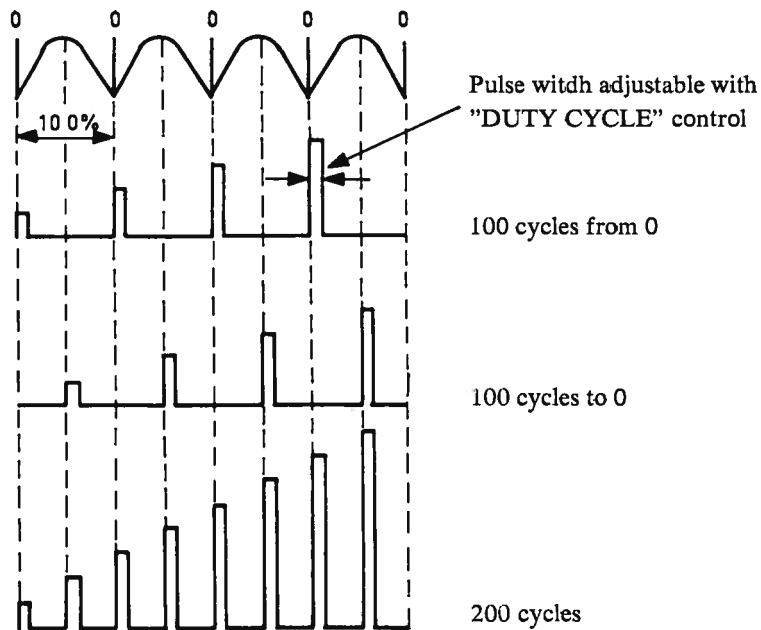





Fig. 9. Front view with controls and sockets



PEM 3841

Fig. 10. Trigger point

- SK2 SOURCE RESISTANCE Ω**
It is possible to include a number of resistors from 0... 10 M Ω in series with base circuit. These resistors serve for current limitation as well as for matching the base circuit.
- SK3** This step switch serves for selection of the number of steps (or curves) to be displayed.
- SK4 RANGE 10 V - 50 V - 100 V - 500 V**
Push-button switch for selection of the collector voltage range.
- SK5 CUT OUT**
Excess-current cut-out for the collector voltage supply.
This thermo-magnetic switch cuts out at an excessive primary current.
Resetting is effected by depressing the red button.
- SK6 READ**
This push-button serves for starting a non-recurrent curve display or, in case of single curve display, for switching to the next step of the characteristic.
- SK7 ONE CURVE - SINGLE FAM. - REP. FAM**
Slide switch for trigger-mode selection
ONE-CURVE - Single curve
In this switch position only one curve is displayed whereby switching to the next step is effected by means of push-button "READ", dependent on the number of curves selected by means of SK3.
SINGLE FAM - One set of curves
In case of triggering by means of push-button "READ" non-recurrent display of the selected set of curves is obtained.
This display method is employed for heavily loaded transistors which do not permit of long-term operation or for photographic recording.
REP. FAM. - Repeated display of the set of curves
In this switch position the selected curves are permanently displayed.
- SK8 }
R901 } DUTY CYCLE**
This control serves for adjusting the duration of a curve, i.e. for adjusting the pulse width of the step signal (also see SK1).
The potentiometer permits adjustment of the pulse width between 2.5... 60 % and in the fully clockwise switch position a duty cycle of 100 % is obtained.
- SK9 HIGH VOLTAGE**
Slide switch of switching on the H.T. generator for testing diodes as regards breakdown voltage. The switch also serves for selection of two measuring ranges, μ A and nA.
These ranges correspond to the ranges of range selector SK16.
- SK10 STEP SELECTOR**
Range selector for adjusting the step values of the base-emitter circuit. The switch covers the three groups of ranges μ A, mA and mV/step. The voltage or current step between two successive curves is determined by this switch.
However, the selected value should be taken into account when establishing the value of the signal on the c.r.t., when SK13 or SK16 is in position .
- SK10A x2.**
All current and voltage ranges can be doubled by means of this push-button (only for brief periods!).
- SK11 TRANSISTOR INPUT**
Slide switch for switching the input potential:
GROUNDED
In this position the input of the semi-conductor under test is connected to earth.
DRIVEN
In this position the input of the semi-conductor under test is driven by the step generator.
OPEN
In this position the input of the semi-conductor under test is open-circuited.
- SK12 COLLECTOR LOAD Ω**
Step switch by means of which resistors of 0... 100 k Ω can be included in series with the collector circuit for current limiting and matching.
In this way the power dissipation of transistors operated near their load limits can be adapted individually which proves to be very useful in practice.
- SK13 COLLECTOR VOLTAGE - BASE VOLTAGE**
Range selector for horizontal deflection of the trace. The values indicated apply to 1 cm screen distance, independent of the step value selected with SK10, except for position .
- In latter position the step value of SK10 applies to 1 cm screen distance.
Position "EXT." serves for external horizontal deflection. Connection is effected via BU6 (sensitivity 10 mV/cm).
- SK13A x.1.**
With this push-button the ranges 100 V, 200 V and 500 V of SK13 can be reduced by a factor 10.
- SK14 }
SK15 } NORMAL - INVERSE - CALIBRATION**
These slide switches serve for polarity reversal of the horizontal (SK14) or vertical deflection (SK15). This enables reversal of the trace in both directions, independent of each other.
Switch position "CAL" serves for checking the display circuit; a direct voltage of 50 mV is then applied to the amplifier inputs.
The indications near range selectors SK13 and SK16 remain valid (with the exception of switch position  as well as the base voltage ranges 10... 100 mV/cm and 20... 200 mV/cm).
The trace on the screen will be 5 cm. For the ranges in brackets the range values selected should be observed, and in position  the sensitivity is 100 mV/cm i.e. a shift of 0.5 cm.

SK16	<p>COLLECTOR CURRENT - BASE VOLTAGE Range selector for vertical deflection of the trace. The range values apply to 1 cm screen distance, independent of the step value chosen with SK10, except for switch position EXT. In this position the step value of SK10 holds good for 1 cm screen distance. Position "EXT" serves for external vertical deflection. Connection is effected via BU6 (sensitivity 10 mV/cm).</p>	R302	<p>X-SHIFT Ganged potentiometer (coarse and fine adjustment) for horizontal shift of the trace.</p>
SK17	<p>x.5 x 1 x 5 Expansion switch. By means of this switch the vertical deflection range (SK16) can be extended by a factor 2 in downward direction and by a factor 5 in the upward direction.</p>	R303	Potentiometer for adjusting the d.c. balance of the X amplifier.
SK18	<p>Toggle switch TS1 - OFF - TS2 for connecting semi-conductor TS1 or TS2. The connection sockets for 4 mm plugs together with the transistor receptacles above these sockets are parallel connected via RF coils. When the toggle switch is in the left-hand position the left hand receptacles and sockets are connected (TS1) and in the right-hand position TS2 is connected. In the centre position the sockets and receptacles are disconnected.</p>	R401	<p>Y-SHIFT Ganged potentiometer (coarse and fine adjustment) for vertical shift of the trace.</p>
SK19	<p>Push-button switch for PNP-NPN selection, changing over the V_{BE} from normal to inverse (polarity reversal of the B-E junction) and changing over from common-emitter to common-base arrangement.</p>	R402	<p>SCALE ILLUMINATION Potentiometer for adjusting the lattice illumination.</p>
SK20	<p>Slide switch for selecting the + or -10 V direct voltage ($\frac{+}{-}$) which may be added to the "S" connection (shield). This voltage is for instance required for transistors with two inputs.</p>	R403	Potentiometer for adjusting the d.c. balance of the Y amplifier.
SK21	<p>POWER ON Mains switch for switching on the apparatus.</p>	R902	<p>ZERO Control for zero shift of the step signal. The lower curve is adjusted to datum or leakage current level by means of R902. For this adjustment SK11 is set at "OPEN", the datum line is read and after SK11 has been reset to "DRIVEN" the lower curve is adjusted to the reading obtained, by means of R902. The datum line is correctly adjusted if the curve does not shift when SK11 is switched from "DRIVEN" to "OPEN".</p>
SK22	<p>Slide switch for the use of the step-generator with external programming. (Accessible via an aperture in the left-hand cabinet plate.)</p>	BU1	Earthing socket.
SK25	<p>Mains voltage adapter 115 V/230 V \pm 15 % (at the rear of the apparatus).</p>	BU2a	Transistor receptacle for small types
T1	<p>VOLTAGE Variable transformer for adjusting the collector voltage and the high tension (when SK9 is switched on).</p>	BU2b	<p>Connection sockets for power transistors } Switch position TS1 Parallel connections</p> <p>The E-B and C-S connections have been provided with Kelvin take-offs (voltage and current fed-out separately to prevent measuring errors)</p>
R1	<p>Potentiometer for adjusting the "SHIELD" voltage from 0 to + or -10 (dependent on the position of SK20).</p>	BU3a	Transistor receptacle for small types
R301	<p>INTENSITY Potentiometer for brightness control.</p>	BU3b	<p>Connection sockets for power transistors } Switch position TS2 Parallel connections</p>
		BU4	<p>BNC sockets for connection of a protective holder or connection cable for testing diodes in the breakdown region (max. 3 kV). (BU4 = measuring input) (BU5 = high voltage output \lesssim)</p>
		BU5	
		BU6	Multiple connector for external control (on the left hand side of the apparatus)
		D1	Push-button to connect the high voltage to socket BU5.
		LA1	On/off pilot lamp
		LA2	<p>Lamps for lattice illumination</p>
		LA3	
		CS1	Mains socket with rim-earthing contacts (at the rear of the apparatus).

D. OPERATION

1. Basic setting

The basic setting of the apparatus depends on the type of semi-conductor and its characteristics as well as on the selected mode.

E.g., for measuring an NPN transistor of relatively low power the setting shown in Fig. 20 may be used. It is advisable to start with a low setting in case of a semi-conductor whose characteristic values are not exactly known. This setting can then be changed if a more accurate measurement is permissible.

2. Switching on the apparatus.

After the controls have been set to the initial position, the apparatus can be switched on with switch "POWER ON". If the transistor is already connected it should be ensured that toggle switch SK18 is in the mid position; in this position the semi-conductors (TS1 and TS2) under test are disconnected.

The heating up time of the curve tracer is approximately 1 minute. After this the apparatus is ready for operation.

3. Connecting of a semi-conductor

For connection of small transistors two receptacles are available and two socket connectors for 4 mm plugs.

The socket connector and the receptacles above it are parallel connected via R.F. chokes. These chokes prevent or suppress parasitic oscillation of R.F. transistors which for the same reason should be connected to the plug connectors.

In the left-hand position of the toggle switch the left-hand receptacles and sockets (TS1) are connected and in the right-hand position the right-hand sockets and receptacles (TS2).

4. Adjusting the display section

The display section should be adjusted to the correct horizontal and vertical sensitivity before the semi-conductor under test is connected. First adjust the spot on the screen by means of the X and Y shift controls. The horizontal deflection corresponds to the collector-emitter voltage. As soon as a voltage is applied a horizontal line is displayed on the screen whose length is a measure of the sensitivity adjusted with SK13 or the collector voltage.

The vertical deflection defines the value of the collector current of the transistor. Before the semi-conductor is connected range selector SK16 should be set to a sensitivity corresponding to the collector current to be expected.

As soon as a transistor is connected a current will flow through the collector circuit which depends on the selected base current or voltage. This current causes a deflection in the vertical direction on the screen, whereby the distance from the datum line to any point of the curve represents the value of the collector current.

The switches NORM./INVERT serve for reversing the trace in the horizontal and vertical direction. An expansion switch permits of extending the vertical measuring range by a factor 2 in the upward direction or by a factor 5 in downward direction.

For the voltage ranges 100 V, 200 V and 500 V of the high voltage generator, a push-button has been provided, which enables an increase of the display sensitivity by a factor 10.

Control INTENSITY serves for adjusting the intensity of the electron beam. To prevent damaging of the picture tube the beam current intensity should not be excessive, but should be adjusted so that a clear picture is obtained.

Balance-adjustment of the horizontal deflection is effected with potentiometer R303.

If a V_{BE} of 20 mV, 50 mV or 100 mV is selected with SK13, R303 should be adjusted so that the movement of the spot is minimum (SK11 at "GROUNDED").

Balance-adjustment for the vertical deflection is effected with R403. While setting SK17 from 1 to x0.5 or x5, R403 should be adjusted so that the electron-beam shift is minimum.

5. Setting for testing semi-conductors with 3 or 4 terminals.

The following description gives a survey of the most important adjustments for displaying a characteristic. The example chosen applies to the display of I_C as a function of V_{CE} , with I_B as parameter, for a PNP transistor in a T0 5 case.

- Set all the controls to the position shown in Fig. 20 (toggle switch TS1 - OFF - TS2 in the centre position).
- Switch on the apparatus (switch POWER ON).
- Insert the transistor in the receptacle, e.g. BU2a.
- Check and preset:
 - V_{CE} - VOLTAGE
 - COLLECTOR LOAD
 - STEP SELECTOR μA , mA/STEP
 - HORIZONTAL DEFLECTION (range)
 - VERTICAL DEFLECTION (range)
- Set the toggle switch at TS1.
- Adjust for desired step current (or step voltage and series resistance SK2 for certain traces), and collector voltage.
- Adjust the horizontal and vertical deflection until proper curve display obtained.
- Adjust step switch "LOAD Ω " so that the curve display is limited (e.g., according to the dotted line in Fig. 12).
- Adjust the level of the lower curve to zero with control "ZERO" by setting slide switch SK11 at "OPEN" and reading the zero line (given by the leakage current of the transistor).
Reset the slide switch at "DRIVEN" and adjust the lower curve to the zero value found by means of control "ZERO".
- By means of control "DUTY CYCLE" the driving time of the step current can be reduced, so that only the beginning of the curve is visible when switch "CURVES/sec." is at position "100 from 0", (Fig. 11a). In position "100 to 0" the second part of the curve trace is visible (Fig. 11b) and in position 200 the beginning and end of curve can be displayed, (see Fig. 11c and description under point 5.1.2).

5.1. Displaying curves with power limiting

The characteristics of semi-conductors at high loads can only be displayed when the semi-conductor cannot be damaged by this high load. For this purpose the curve tracer offers the following possibilities:

5.1.1. Curve display with limited duty cycle of the step current (DUTY CYCLE) 100 from 0 or 100 to 0.

When a curve trace of a transistor is displayed the highest power dissipation occurs during the transition from the conductive to the non-conductive state. Fig. 12 shows a curve trace whereby the power dissipation limit P_C max. of ... mW is represented by the dotted line. This display method with limiting at P_C max. can be approximated with the curve tracer.

This is obtained by reducing the duty cycle of the step current (DUTY CYCLE) and by current limitation with series resistors included by means of the step switch (LOAD Ω). By means of the DUTY CYCLE control adjustment of the step width between 2.5 ... 60 % and 100 % is possible (see Fig. 10 and the description under point C1).

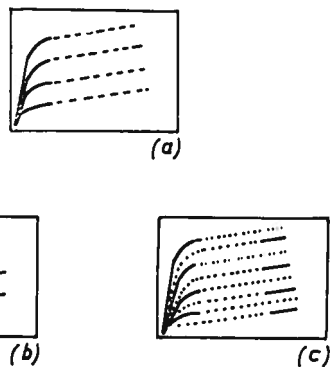

Fig. 11. Effect of the duty-cycle control

These two methods enable reducing of the load of the semi-conductor under test to a minimum by displaying only that part of the characteristic which is of interest. The semi-conductor may then be loaded to high values without the risk of being overloaded.

5.1.2. Curve display with limited duty cycle of the step current, 200 Hz.

When the number of steps is even the curves are shifted to the beginning or end. In cases of an odd number all curves are uninterrupted but, dependent on the duty cycle adjustment, the centre parts are driven to zero and become consequently interrupted or overlap.

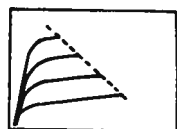

Fig. 12. Curve display with current limiting

In this way a survey of the entire characteristic is obtained at a limited load.

5.1.3. Curve display with current limiting by means of series resistors in the collector circuit.

Dependent on the base drive of a transistor currents will flow through the collector circuit which are a factor h_{fe} higher. When series resistors are included in the collector circuit a voltage drop will arise across this resistance which causes a decrease of the collector-emitter voltage of the semi-conductor under test which depends on the transistor drive. In this way a power limitation is obtained which can be adapted to the maximum permissible value of the transistor and which can be adjusted to any value within the resistance and voltage ranges (Fig. 12).

5.1.4. Non-recurrent curve display

If certain transistor settings do not permit of continuous operation, display in the "single" mode is possible.

For this slide switch SK7 is set at "SINGLE FAM". Triggering is effected by means of push-button "READ" (SK6).

5.1.5. Curve display of one curve out of the set of curves.

From a set of curves, the number of which can be selected by means of switch STEP/FAM, each curve can be displayed individually. Switching over to a higher step is effected by means of push-button "READ" (SK6).

5.2. Displaying curves with voltage drive.

5.2.1. Transistors

a. Leakage current measurements I_{CEX} , I_{CEO} , I_{CER} , I_{CES} and breakdown voltage BV. (Fig. 13).

Leakage current measurements I_{CER} , as well as breakdown voltage measurements BV_{CER} can be effected by means of the resistors from 0Ω (CES) to $10 M\Omega$ (CER) which can be switched by means of SK2 (SK10 in position 0 mV/Step). Open base measurements ($R_{BE} = \infty$ /CEO) can be effected with SK11 (INPUT OPEN).

Measurements with voltage and resistance (CEX) can be effected as described above, however, SK10 should be adjusted to voltage (... mV/Step) and the polarity (SK19 A V_{BE} INVERS) should be reversed. By means of control R902 "ZERO" any voltage value can be selected.

During this measurement it should be observed that the power dissipation near the breakdown limits can be very high, so that it is recommended to limit the power dissipation by including resistors in the collector circuit.

b. Setting at small base currents:

Transistors with a high current gain can be measured most efficiently at a small I_C when the voltage drive on the base takes place via a high load resistance.

Example: 100 mV/step — 1 MΩ $I_B = \frac{100 \text{ mV}}{1 \text{ M}\Omega} = 100 \text{ nA/ step.}$

Compensation of the voltage in the non-linear part of the base-emitter diode characteristic is then possible by means of control R902 (Zero); see Fig. 14.

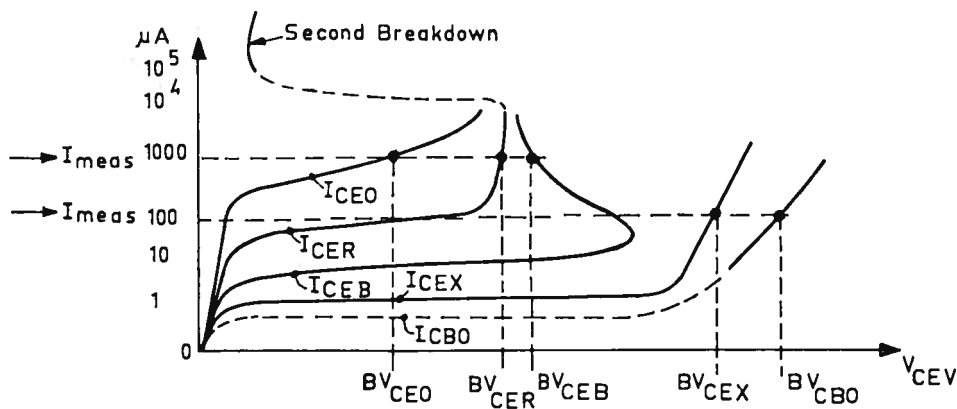

PEM 3840

Fig. 13. Breakdown characteristics

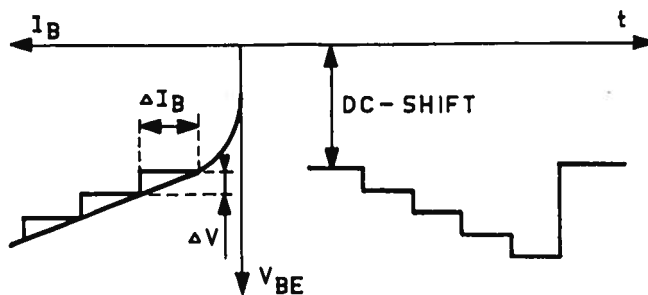

PEM3839

Fig. 14. Compensation for the non-linear part of the base-emitter diode characteristic

5.2.2. Voltage driven elements such as FET:

a. Junction FET (also see 5.3).

Depletion - type MOS - FET.

With these semi-conductors there is already a drain current (I_{DON} , I_{DSS}) at a gate-source voltage of zero volts. When the gate is driven by the step voltage this current varies.

The curves can then be changed by selection of the polarity and the internal resistance (Fig. 15).

b. Enhancement - type MOS - FET.

In this type of transistor normally no drain current will flow without gate source voltage (Fig. 16).

As soon as a sufficiently high gate-source voltage is applied the drain current starts flowing (gate-source cut-off voltage).

5.3. Additional drive on a 4th connection (e.g. 2nd gate).

With the aid of control R1 and switch SK20 the 4th electrode can be employed for driving so that special measurements are possible.

6. Setting for breakdown tests of diodes and other elements with 2 connections.

Because of the high voltages and high sensitivity the outputs and inputs have been isolated. The voltage is adjusted by means of variable transformer T1 and switch SK9 enables a division into two current ranges. For safety reasons the test voltage is cut out as soon as button DS1 is released.

A second safety contact is available when adapter PM 6546 which is supplied separately, is employed for testing diodes.

The voltage is then switched on only, if the cover is fitted and push-button D1 on the instrument is depressed.

Connection and operation of adapter PM6546

— Connect the adapter to the PM6507.

The short plug should be connected to BU4 (–, top) and the long one to BU5 (+, bottom).

— Insert the semi-conductor under test into both clips in the adapter. To this end the sliding screen should be removed by lifting it out of its guide.

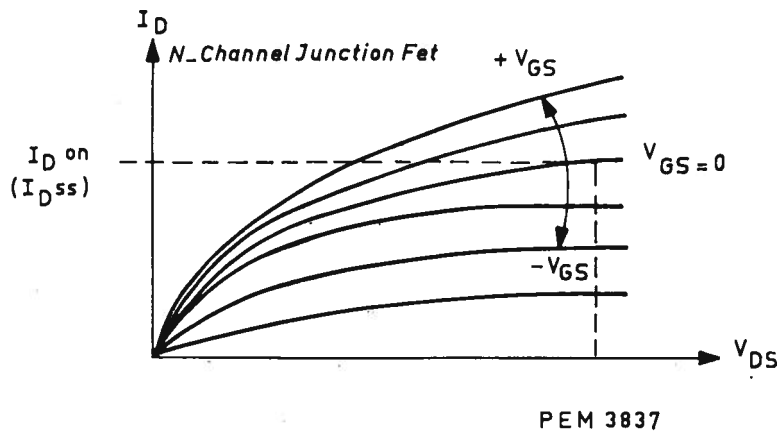

Fig. 15. I_D - V_{DS} -characteristic of an N-channel junction FET

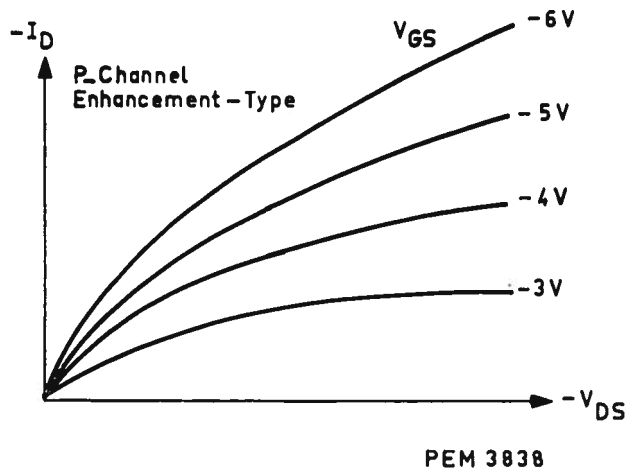

Fig. 16. I_D - V_{DS} -characteristic of a P-channel enhancement-type MOS-FET

For measurements in reverse direction, the cathode of the semi-conductor under test should be connected to the positive clip (marked + ∇). This electrode is connected to the high-voltage when the switch in the adapter is depressed.

- The screen has two different openings. Depending on the semi-conductor under test, the big or small opening can be chosen, so that the anode connection is well screened against stray capacitance. Therefore the screen should be slid as far as possible over the semi-conductor under test (Fig. 17). For insensitive measurements it is not necessary to use the screen.

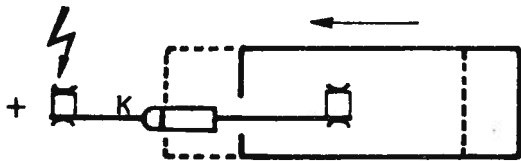

Fig. 17. Position of the screen over the semi-conductor under test

Switching in

- Close the lid. Thereby the push-button SK1 is depressed automatically, by which the high-voltage connection of the semi-conductor under test is included into the circuit.
- Depress push-button DS1 on the PM6507; by this the high-voltage is switched in and applied to the adapter.

WARNING

MEASUREMENTS WITH HIGH VOLTAGES HAVE TO BE CARRIED OUT WITH CLOSED LID ONLY. NEVER DEPRESS THE PUSH-BUTTON ON THE ADAPTER MANUALLY.

Function of switch SK2

In position ∇ normal operation with half-wave voltage occurs (Fig. 18, upper display).

In position C a capacitor is incorporated into the high-voltage circuit. Consequently an integrated supply develops, so that the diode characteristic is not written from the origin. By this the influence of the switch and junction capacitance on the display is reduced. Nevertheless the breakdown of a diode can be observed under dynamic conditions as a result of the superimposed ripple voltage.

By depressing push-button DS1 on the PM6507 periodically, the complete quasi-static leakage-current or breakdown characteristics of the semi-conductor under test can be displayed. The fly-back occurs with a time-constant of 0.6 s. (Fig. 18, lower display).

REMARK

When switch SK2 occupies position C, a voltage drop arises over the capacitor load and the internal resistance of the voltage source, so that only 70 % of the peak value of the half-wave voltage is available.

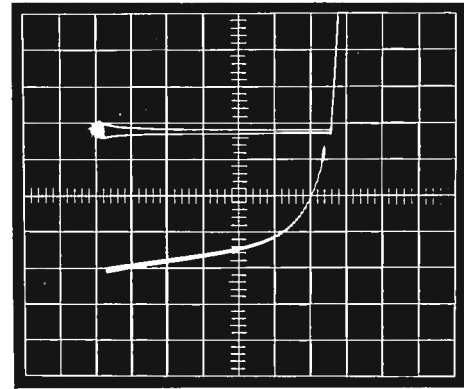

Fig. 18. Display in positions ∇ and C of PM 6546

7. Setting the instrument for external control or programming:

a. Application as X-Y oscilloscope

Connector BU6 on the left-hand side of the instrument can be employed for X-Y display. The inputs are arranged as follows:

- ∇ Socket H/K
- X1 Socket D
- X2 Socket F
- Y1 Socket B
- Y2 Socket E

b. Special measurements:

- Circuit for testing tunnel diodes
- Circuit for simultaneous display of two characteristics.

c. External programming of the step generator and external measuring circuits:

Automatic operation can be obtained by means of an external adapter. Independent of its normal application and the application as an X-Y oscilloscope the instrument can also be used as an automatic curve tracer.

The external programming unit is connected to connector BU6 on the left-hand of the instrument. The basic arrangement for external programming appears from circuit diagram Fig. 19.

The auxiliary unit should be proportioned so that it agrees with the application and type of semi-conductor under test.

The following formulas serve for calculating the desired operating values in the step voltage generator and the collector supply.

Selecting reference resistor R_X in the step generator.

This resistor determines the step current per stage.

$$\text{For } I \geq 500 \mu\text{A/step} \quad R_X = \frac{100}{I (\text{mA/step}) - 1} [\Omega]$$

$$\text{For } I \leq 500 \mu\text{A/step} \quad R_X = \frac{100}{I (\mu\text{A}) - 1} [\text{k}\Omega]$$

Collector voltage:

This voltage should be preselected so that it corresponds to the max. test voltage. Lower voltages can be obtained by means of an external voltage divider (R_C), the series resistors simultaneously ensuring current limitation.

The horizontal deflection sensitivity of the monitor is determined by the two measuring voltage dividers A and B. These dividers can be made identical to the internal divider (R346-R357 and R332-R334), whereby the intermediate stages which are not required may be left out.

Collector current:

Measuring resistance R_I is defined as follows:

$$R_I (\Omega) = \frac{10 \text{ mV/cm}}{1 \text{ mA/cm}} = 10 \Omega \quad R_I \text{ max} \leq 10 \text{ k}\Omega$$

(1 mA has been chosen as an example)

Base voltage:

For curve display as a function of the base-emitter voltage the X input should be connected to the base-emitter junction of the semi-conductor under test. The voltage divider to be employed should then be high-ohmic, so that the shunt of the base-emitter junction is small.

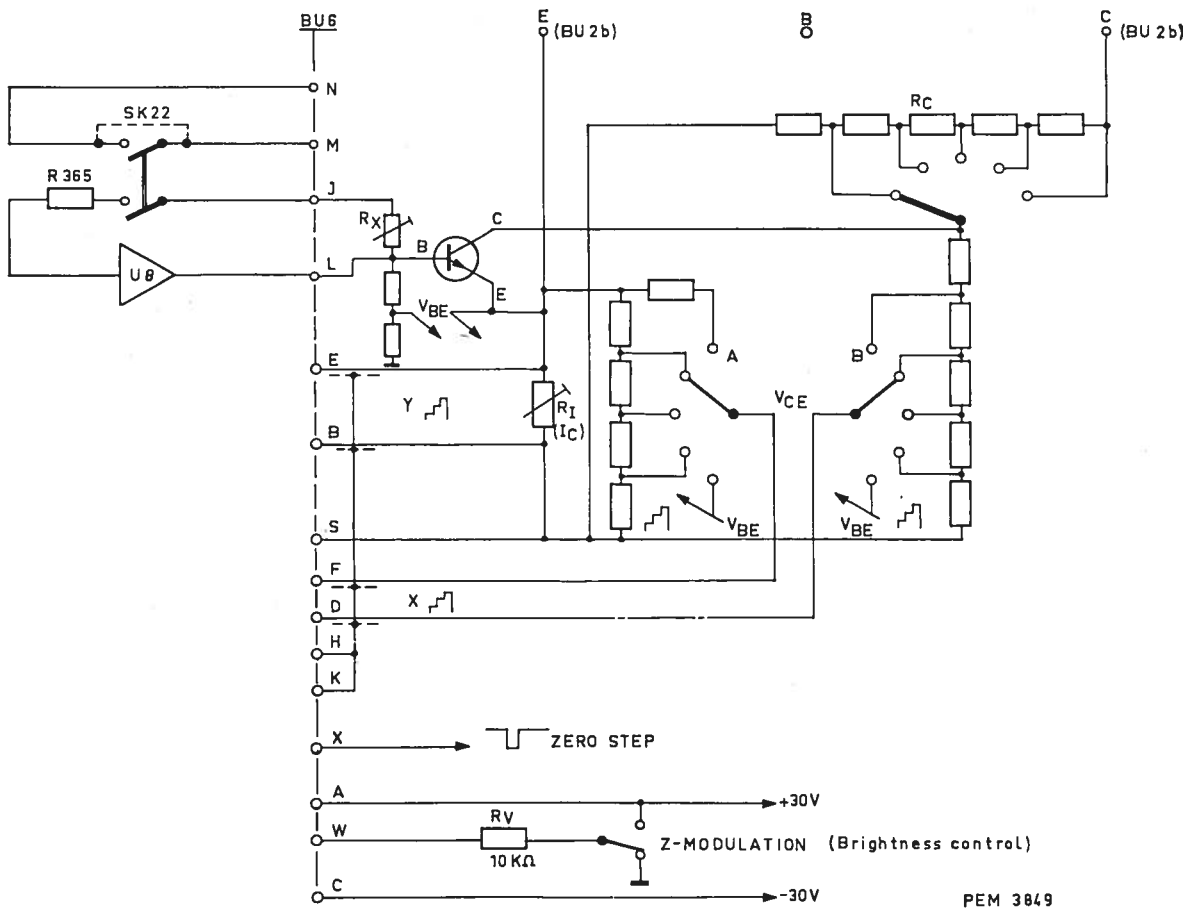

Fig. 19. Circuit for external programming

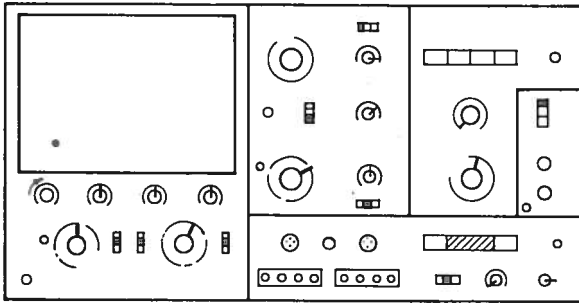

Fig. 20

Basic setting
Adjust spot
NPN-TRANSISTOR

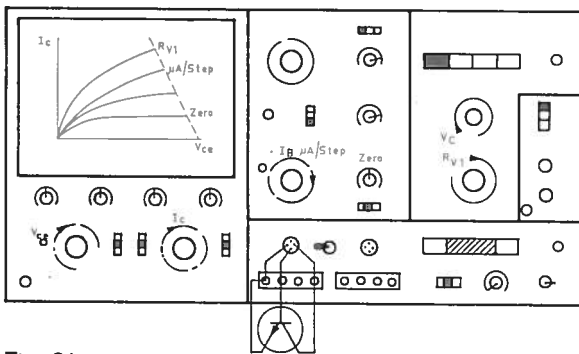

Fig. 21

Charact. $I_C = f(V_{CE})$
 $I_B = \text{Parameter}$
NPN-TRANSISTOR

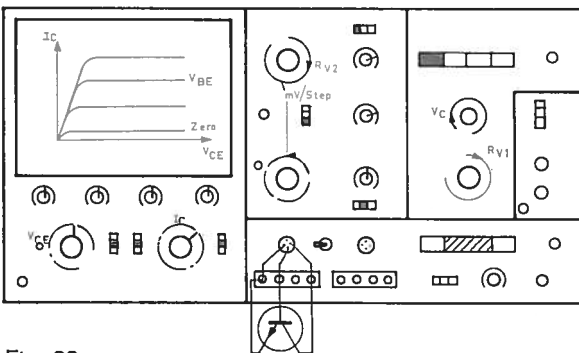
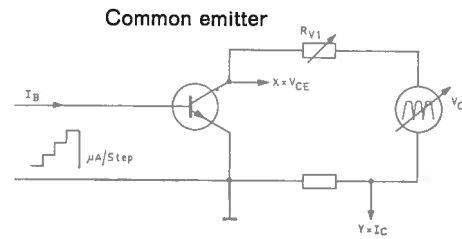

Fig. 22

Charact. $I_C = f(V_{CE})$
 $V_{BE} = \text{Parameter}$
NPN-TRANSISTOR

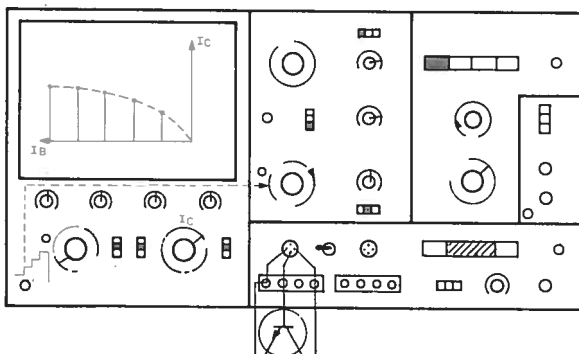
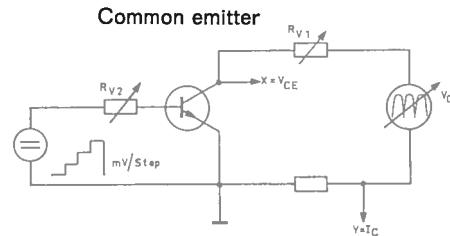
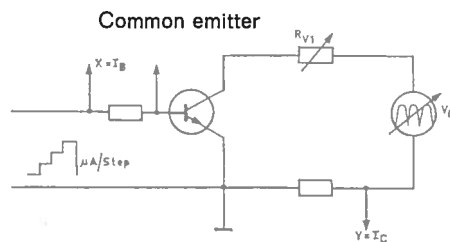

Fig. 23

Charact. $I_C = f(I_B)$
NPN-TRANSISTOR



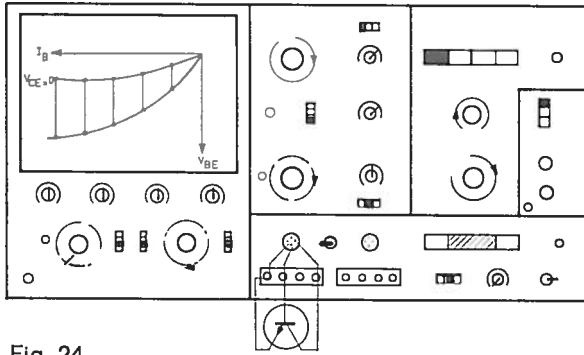

Fig. 24

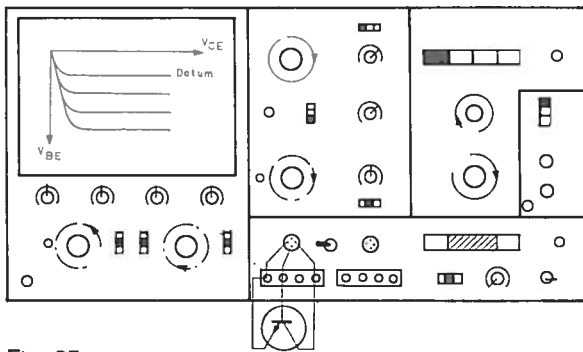
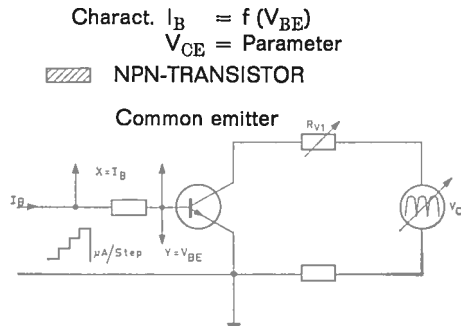

Fig. 25

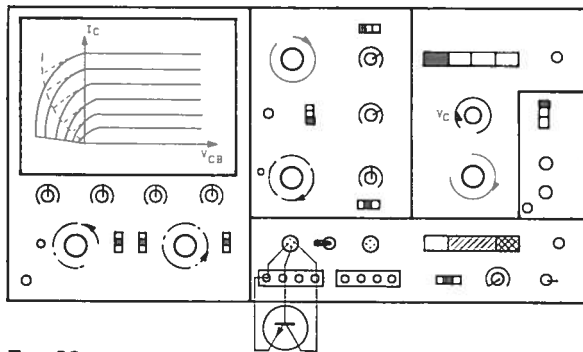
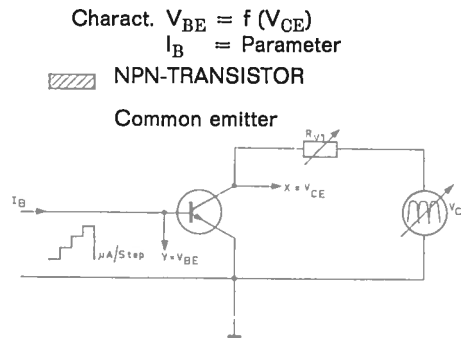

Fig. 26

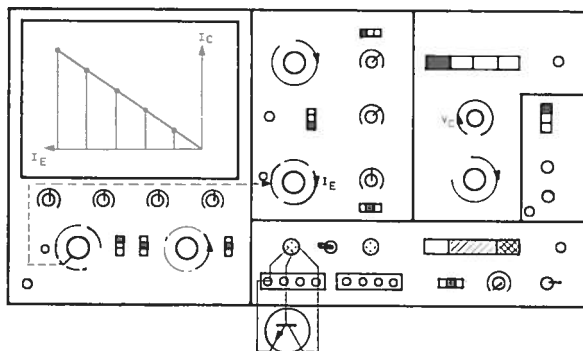
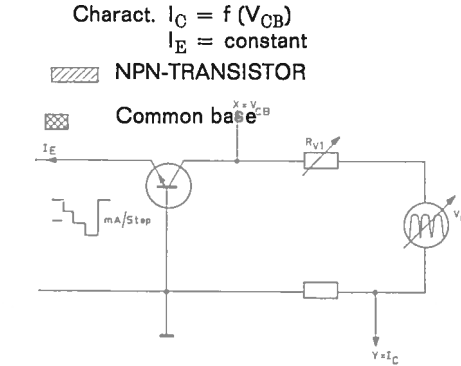
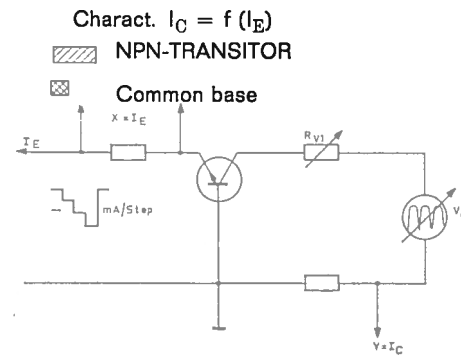

Fig. 27



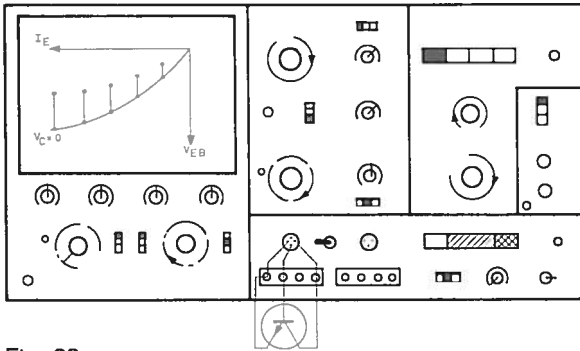

Fig. 28

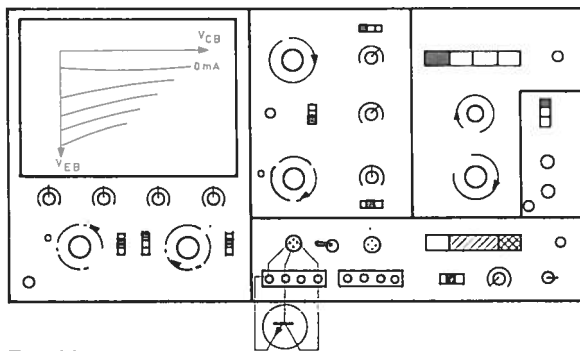
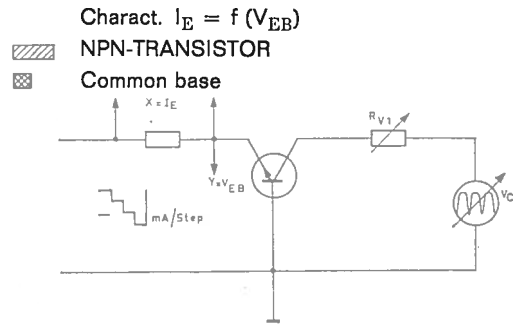

Fig. 29

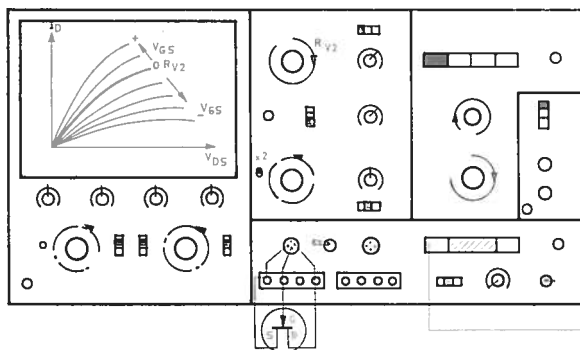
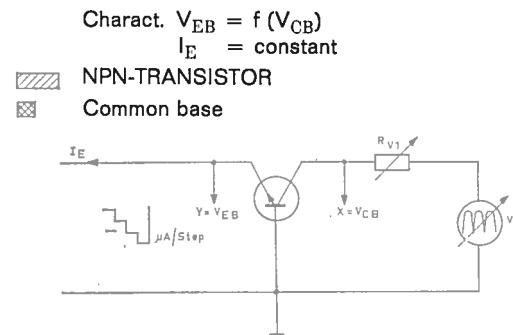

Fig. 30

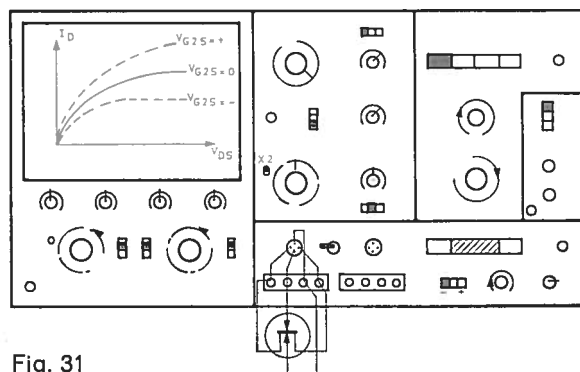
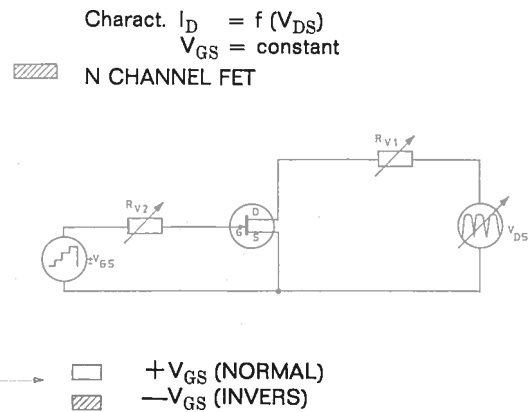
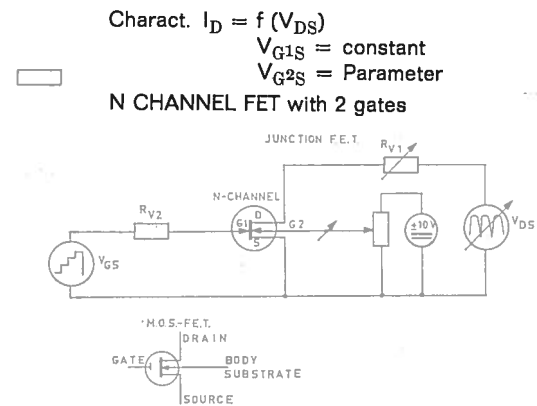

Fig. 31



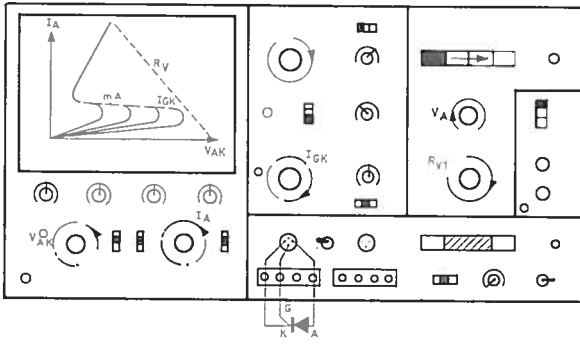

Fig. 32

**Silicon controlled rectifier
THYRISTOR (SCR)**

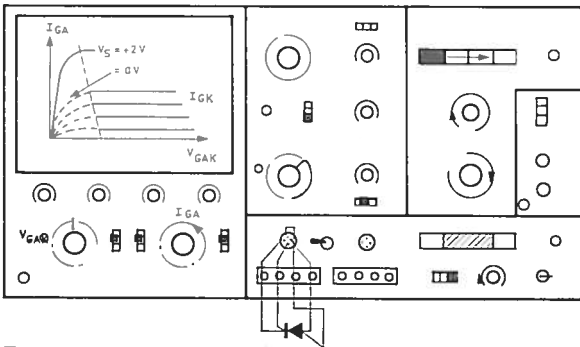
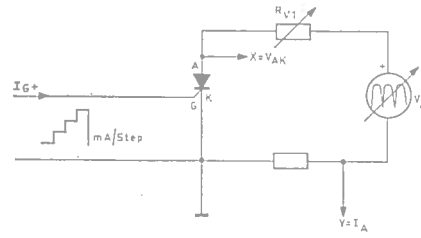

Fig. 33

**Silicon controlled switch
(SCS)**

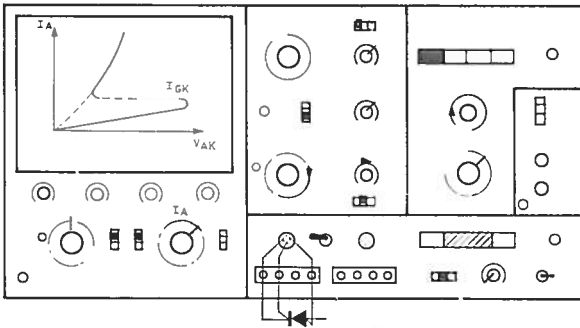
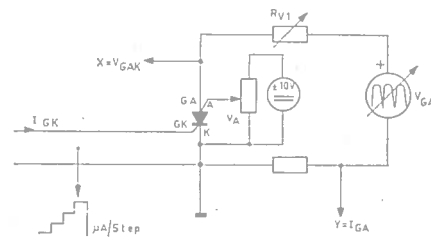

Fig. 34

(SCS)

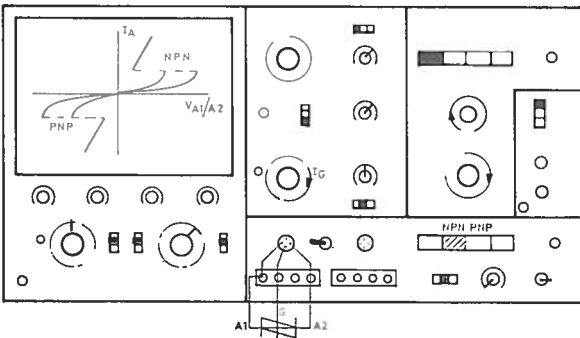
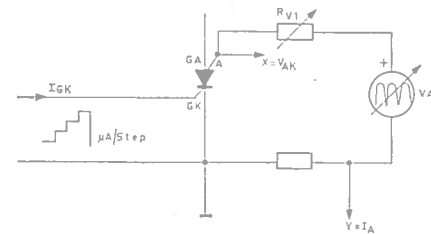
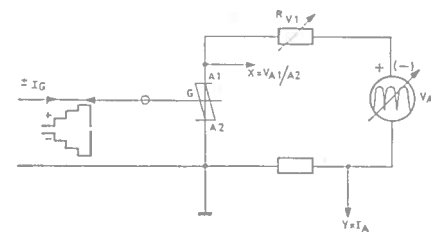

Fig. 35

**UNILATERAL SWITCH
BILATERAL SWITCH**



BILATERAL

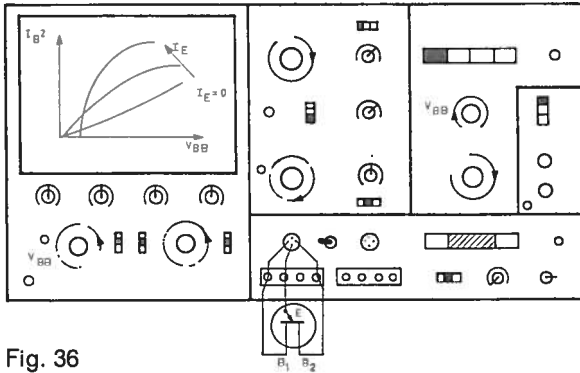

Fig. 36

UNIUNCTION-TRANSISTOR (UJT)

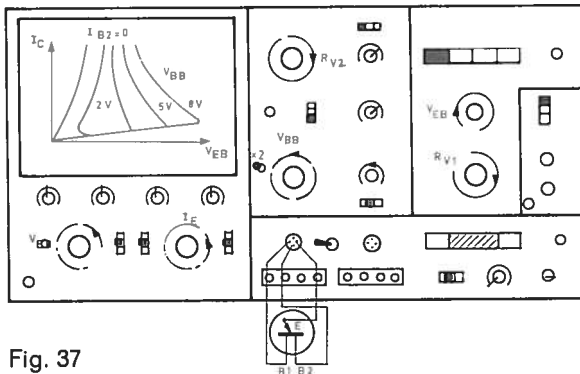
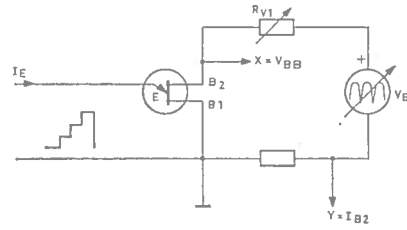

Fig. 37

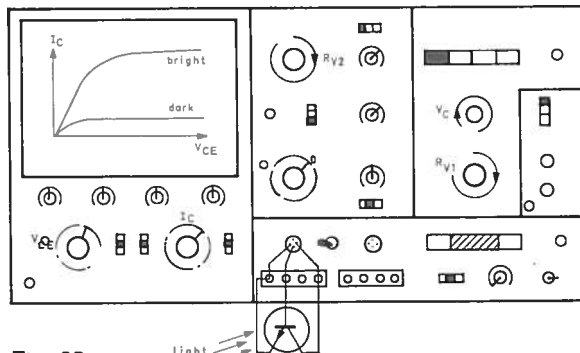
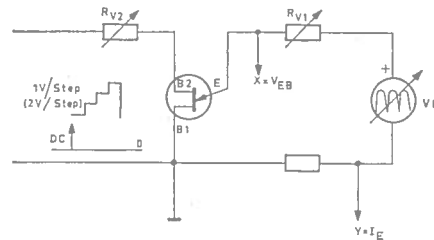

Fig. 38

FOTO-TRANSISTOR NPN

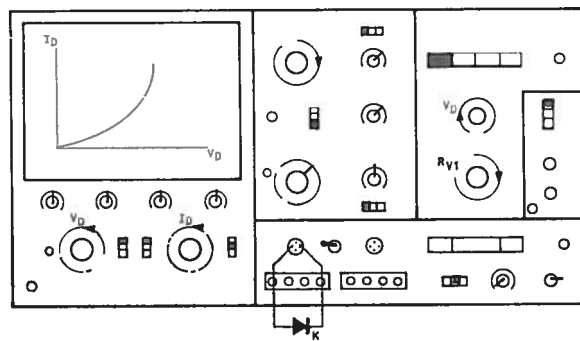
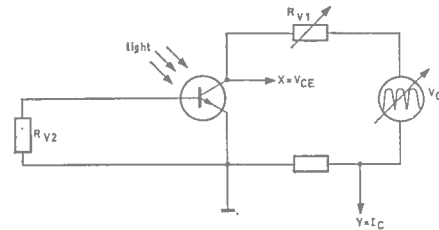
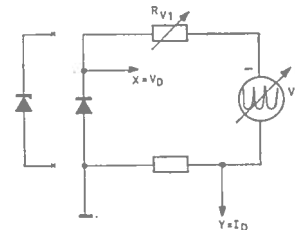

Fig. 39

Forward direction
Zener diode
Diode



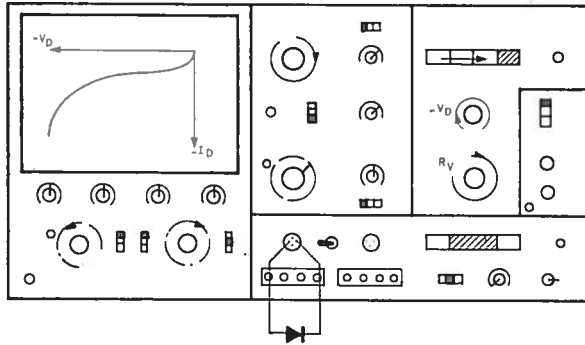

Fig. 40

Leakage current measurement
breakdown
DIODE reverse direction
NPN

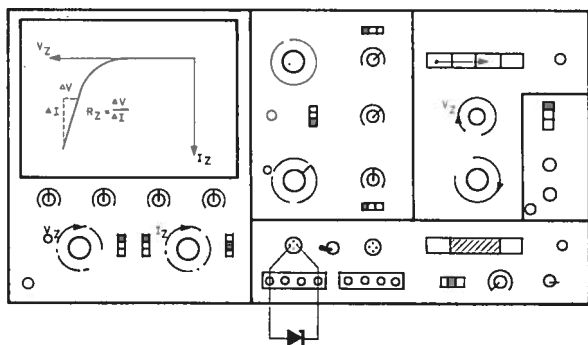
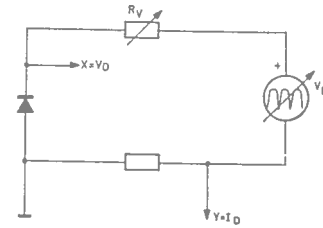

Fig. 41

Zener diode
Zener range
Expansion and shift 10 x screen
NPN

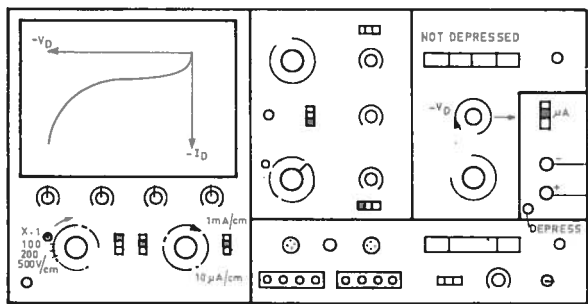
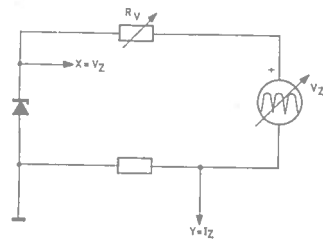

Fig. 42

Diode breakdown voltage
Measuring range 10 μA - 1 mA

Danger

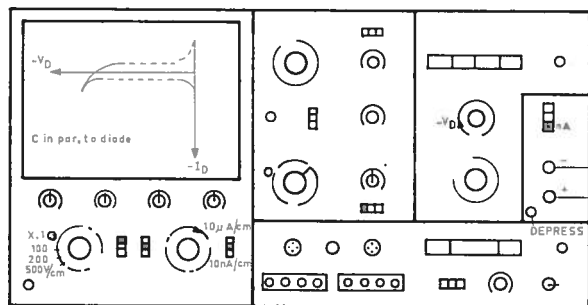
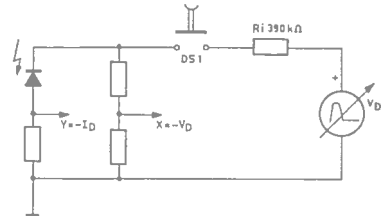
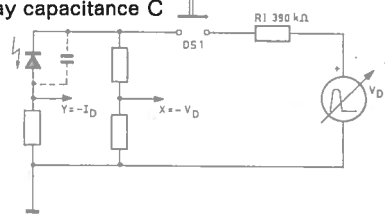

Fig. 43

Diode breakdown voltage
Measuring range 10 nA - 10 μA
Pay attention to screening to
avoid stray capacitance C



With adapter PM 6546
no influence of C

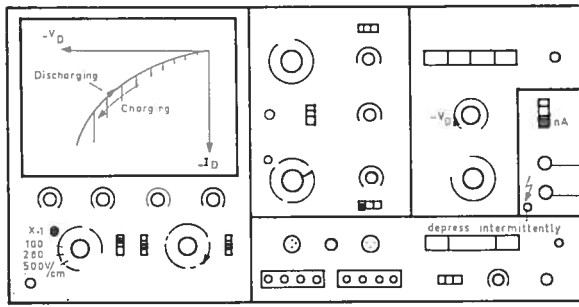

Fig. 44

Diode breakdown voltage
Measuring range 10 nA - 10 μ A SK1 = cover switch
with adapter PM 6546 and C
switched in

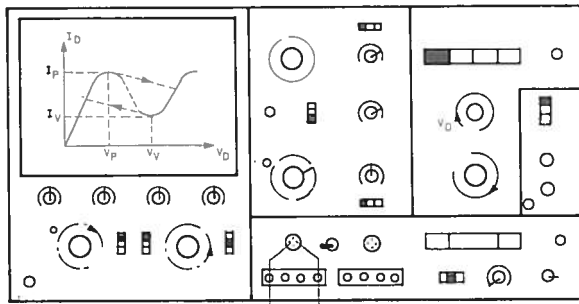
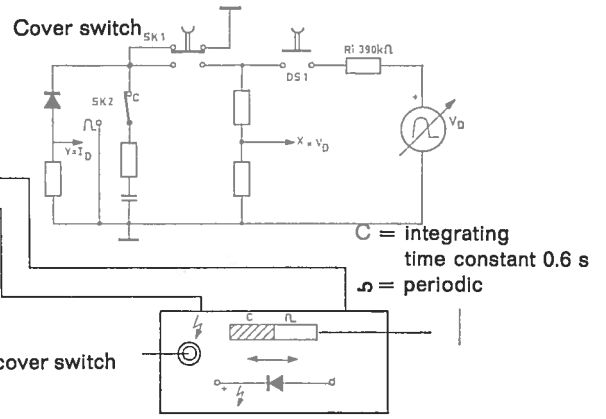

Fig. 45

Tunnel-Diode
PNP

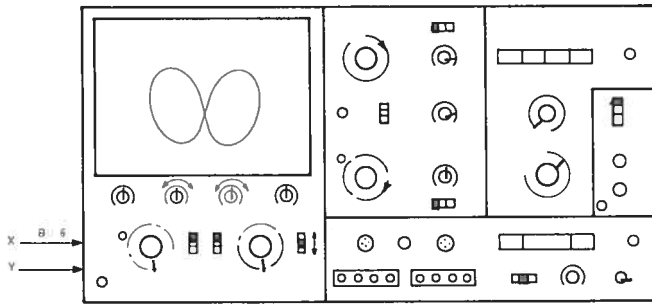
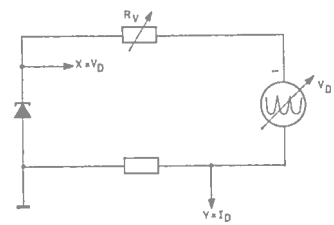

Fig. 46

External operations as
X-Y-oscilloscope

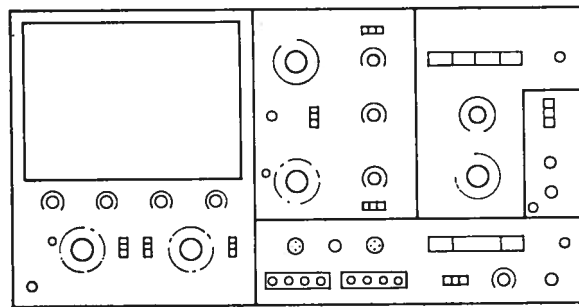
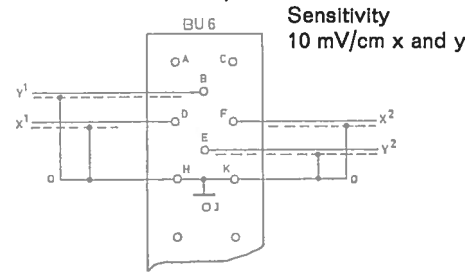

Fig. 47. Various measurements with the curve tracer

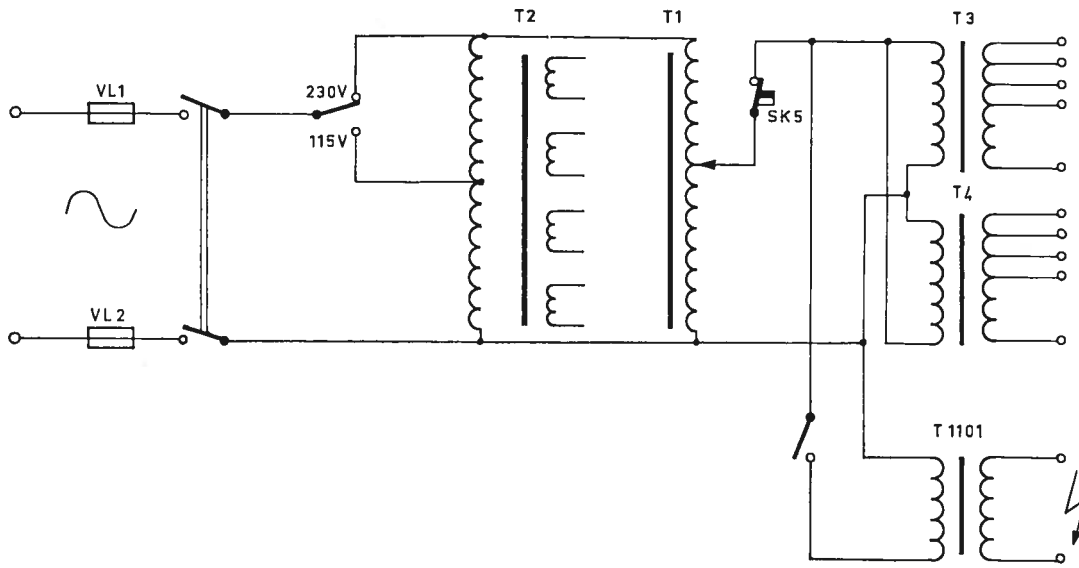

Fig. 48. Supply part

PEM 3850

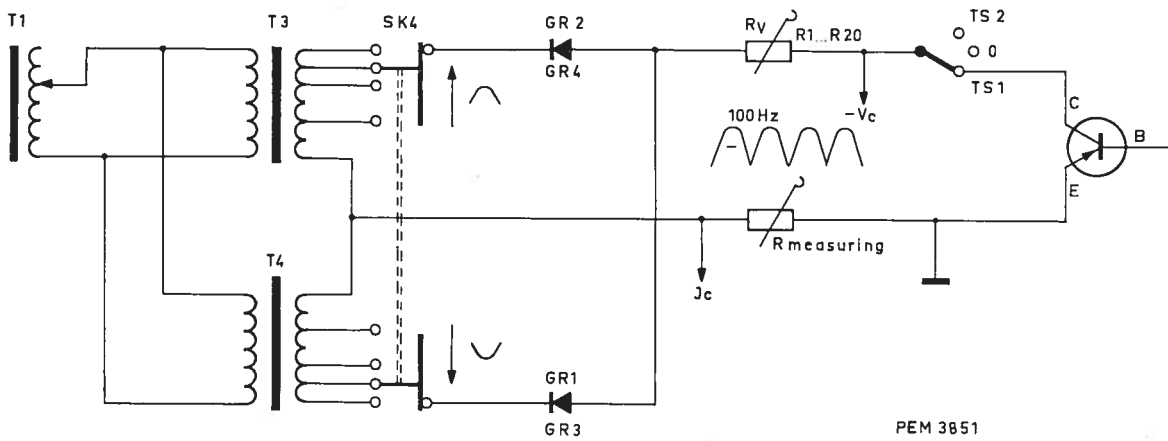

Fig. 49. Collector-voltage source

PEM 3851

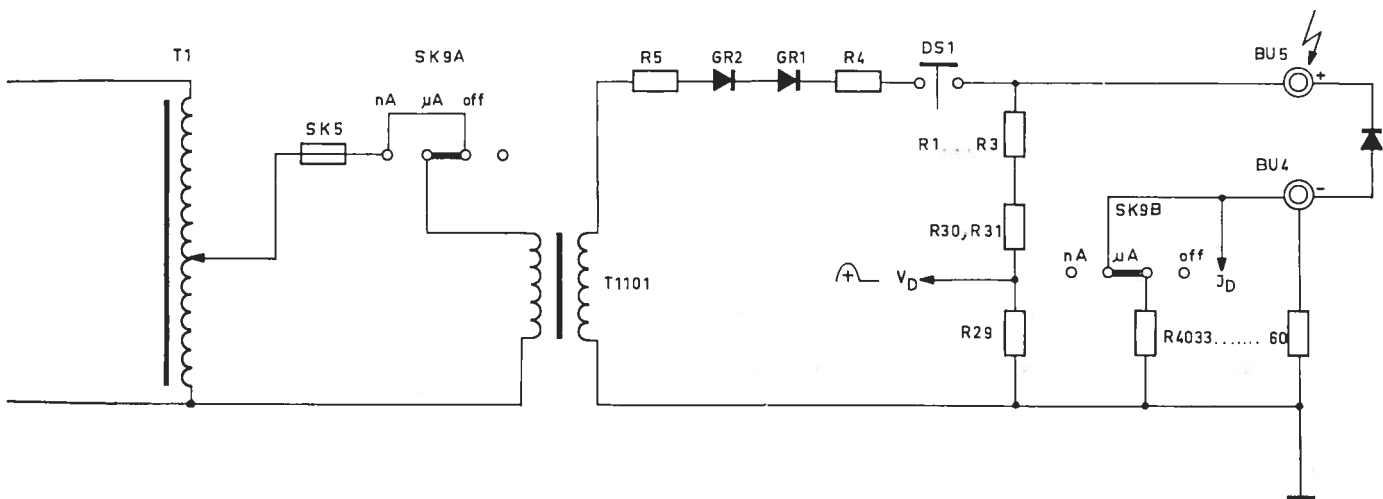

Fig. 50. H.T. source

PEM 3852

SERVICE DATA

VIII. Circuit description

NOTE: The hundreds of the electrical-component numbers refer to the unit to which these components belong. E.g. GR714 means GR14 of unit 7.

A. SUPPLY SECTION

1. Mains supply

The PM 6507 is supplied via a mains transformer and a variable transformer. At mains voltages of 230 V \pm 15 % autotransformer T1 is connected in parallel to the primary of mains transformer T2. When the voltage adapter is set at 115 V transformer T1, which can only operate at 230 V, is supplied via the primary of T2 (Fig. 48).

Variable transformer T1 serves for continuous adjustment of the collector voltage which is delivered by the two transformers T3 and T4.

T1 moreover serves for continuous adjustment of the high tension on the transformer T1101. Mains transformer T2 has four isolated windings on the secondary side which deliver the voltages for the (partially stabilised) direct voltage sources as well as the trigger voltages for the step generator.

2. Collector voltage supply

The two symmetrical transformers T3 and T4 supply 4 alternating voltages which are shifted 180° in phase with respect to each other. The voltage ranges are selected by means of the push-buttons of SK4. Two pairs of diodes (GR3 and GR4 for the 10-V, 50-V and 100-V ranges and GR1 and GR2 for the 500-V range) supply a pulsating direct voltage of 100 Hz. Via the current limiting resistors RV and measuring resistor R this voltage is applied to the collector-emitter junction of the semi-conductor under test (Fig. 49). Fine adjustment of the collector voltage is effected with variable transformer T1. This enables continuous adjustment from 0 to maximum in each voltage range. The values on the scale of variable transformer T1 and the voltage ranges of the push-buttons are the approximate maximum values. The pulsating direct voltage should not be smoothed, in order to obtain complete curve display.

3. H.T. supply

For measuring the breakdown voltage or leakage current of diodes, transistors and high-ohmic resistors a 3-kV H.T. supply has been provided. The basic circuit diagram of this voltage source is shown in Fig. 50. H.T. transformer T1101 is supplied via variable transformer T1. As a result of this the voltage can be adjusted continuously from 0 to 3 kV. Diodes GR1 and GR2 serve for rectification so that a half-wave voltage of positive polarity is available on socket. BU5 when button DS1 is depressed. A functional diagram of the measuring circuit is given in Fig. 60. On the positive

side the voltage is divided into three measuring ranges of 100, 200 and 500 V/cm by SK13/II and resistors R329...31 and R1101...3. The output voltage of SK13/II is applied to the horizontal amplifier.

In case of a leakage current measurement measuring range μ A or nA is selected with SK9. The individual ranges are divided accordingly by means of switch SK16II+IV, and SK16/V+VI. Diodes GR421 and GR422 serve for protection against excess voltage in the mA ranges and GR1301 in the nA ranges. R1304 serves for 0 adjustment (nA ranges!).

Caution! High tension.

When using the H.T. source do not touch the semi-conductor under test!

4. Direct voltage source +31.5/ +30/0/−30 V, U7

Transformer winding 9-10-11 of T2 supplies the alternating voltage to rectifier GR702 which delivers two equal voltages. Smoothing is effected in the first by means of C711 and C721.

Apart from the additional output voltage of 31.5 V the stabilising circuits of these two voltages are practically identical. Therefore the circuit description may be restricted to the +30 V output voltage.

Zener diode GR714 is the reference source and in combination with R712 determines the voltage at the base of TS706. This transistor together with TS705 forms a difference amplifier and R710 and R711 are the load resistors. Common emitter resistor R709 together with R710 and R711 determines the setting for these two transistors. The output voltage is present across resistors R706 and R707/708. The base of TS705 then practically has the same level as the base of TS706. TS704 is driven by the voltage difference which arises in the difference amplifier as an output voltage variation. As a result of this the collector-emitter current of TS704 will vary and thus the voltage on the base of TS702. Transistors TS702 and TS701 form a cascade circuit: TS701 assumes such a setting that the output voltage corresponds to the nominal value but for the regulating voltage difference.

Regulation:

In case of a load increase the output voltage will slightly decrease. The voltage on the base of TS706 will remain practically constant due to the stabilising action of the zener diode. The voltage on the base of TS705 however, decreases so that the collector-emitter current of this transistor is reduced. The voltage on the base of TS704 will consequently become more positive and a larger base current starts flowing and consequently a higher collector emitter current. The bases of TS702 now becomes more negative and a larger collector-emitter current flows, so that the base-emitter voltage of TS701 will increase. The internal resistance of the collector-emitter junction of TS701 will now decrease and a larger current will flow through the output circuit so that the voltage will in-

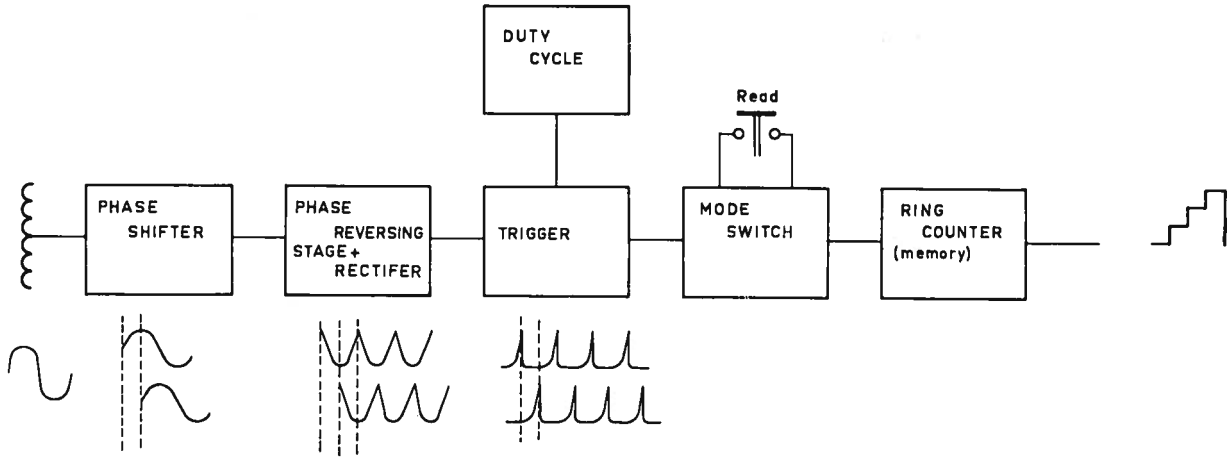

PEM 3853

Fig. 51. Step-voltage generator

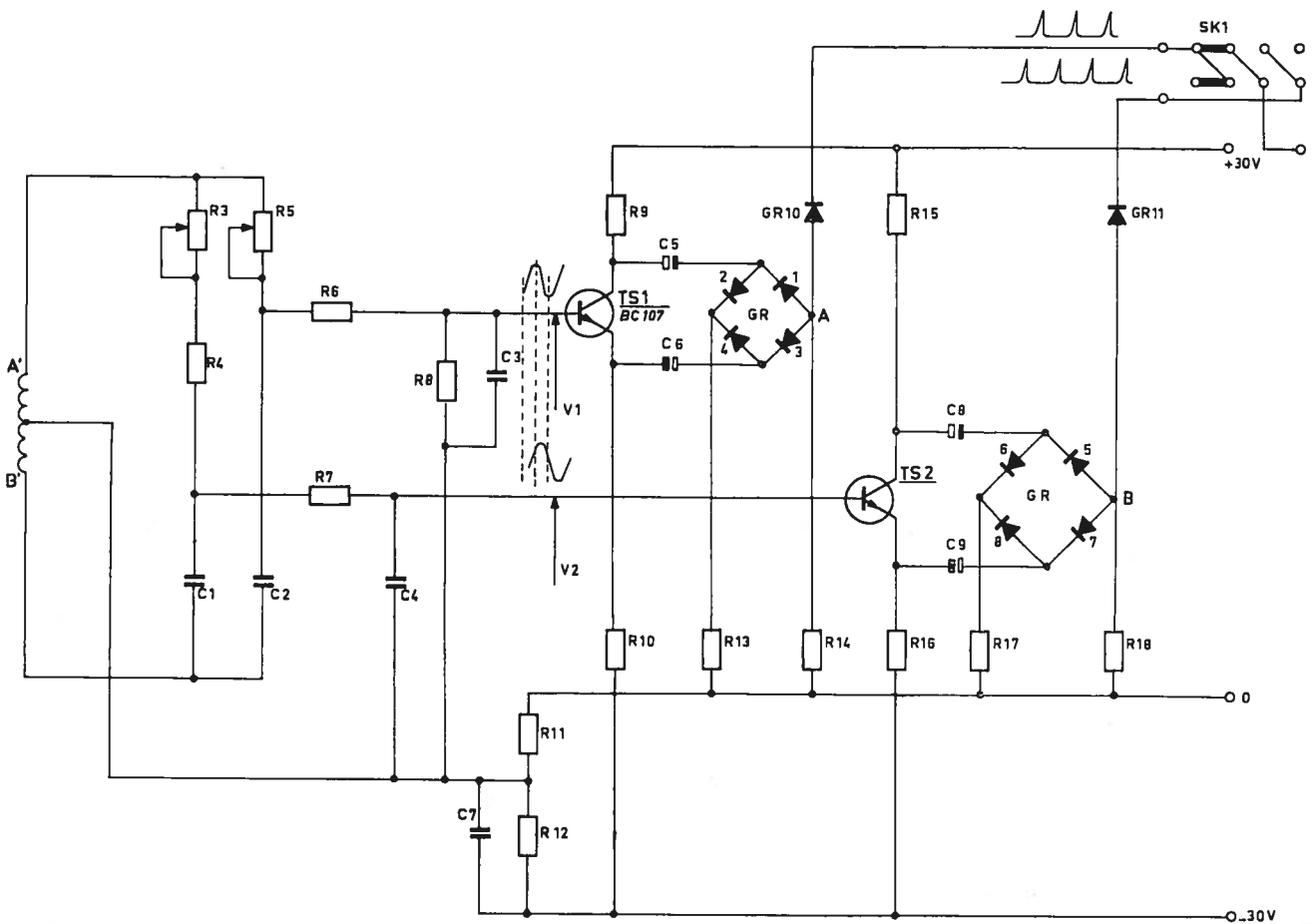

PEM 3854

Fig. 52. Trigger circuit (U9)

crease until the regulating process is stable. The additional 1.5 V voltage is derived from the voltage of TS701 by means of diodes GR712 and GR713 which, in combination with R703, form a voltage divider. Thus a voltage of approximately 1.5 V is obtained on the diodes.

Current limiting:

If the stabilised voltage source is overloaded a larger voltage drop will arise across R701. As soon as this voltage drop is larger than the V_{BE} of TS703 + V_D of GR711, transistor TS703 will become conductive and will consume the base current of TS702. Thus current limitation is obtained.

B. STEP GENERATOR

The basic construction of the step generator appears from the diagram given in Fig. 51: Phase shifter, rectifier + amplifier stage, trigger stage, duty cycle circuit, mode selector, ring counter.

The output signal is a step voltage the number of steps, step width and frequency of which can be adjusted by means of the relevant controls.

1. Phase shifter, amplifier and rectifier, pulse shaper (Fig. 52)

The phase shifting elements, R903/4 and C901 as well as R905 and C902 are connected to winding 15-17 (A' and B').

The voltages V1 and V2 which are adjustable in phase can be adjusted by means of R903 and R905, and are smoothed by means of filter R907/C904 and R906/C903. Phase-inverter transistor TS901 and TS902 have collector voltages which are 180° shifted in phase.

The two diodes GR901/903 and GR905/907 serve for full-wave rectification of the voltage. Charging of capacitors C905/6, 8/9 is prevented by diodes GR902/904 and GR906/908 respectively. The half-wave voltages on points A and B are shifted 90° in phase with respect to each other. The bases of TS901 and TS902 are connected to minus potential via a voltage divider consisting of R911 and R912. As a result of this the lower peaks of the half-wave voltage drop below the circuit zero level. On account of this, short trigger pulses are obtained across diodes GR910 and GR911. These pulses can be selected by means of SK1 and drive the trigger generator (see Fig. 103).

Transistors TS903, 904 and 905 form a pulse shaper which converts the pulses from GR910 and GR911 into an amplified trigger signal of a well-designed shape. The pulses applied to the base of TS904 cause an increase of the collector-emitter current. As a result of this the base of TS903 becomes more negative and so does the emitter and consequently the base of TS905. The collector-emitter current of TS905 increases so that its collector and consequently the base of TS904 will become more negative. This takes place very fast due to the positive feedback so that TS905 discharges capacitor C910. As a result of this a positive voltage surge arises on R927. Because F926 cannot supply such a large current, the collector of TS905 becomes more negative again and blocks the base of TS904.

As a result of this the circuit is reset to its rest condition until the next half-cycle of the switching process

is started. Via C913 and trigger mode switch SK7 the output pulse is applied to the ring counter and via C911 to the duty cycle control circuit.

2. Duty cycle

By means of the duty cycle controls (R901 and SK8) the duty cycle of the step signal can be varied from 2.5 ... 60 % or 100 %.

The duty cycle switch basically consists of a bistable multivibrator with transistors TS906 and TS907 which are coupled by means of RC element R901 and C914/15. From C911 positive trigger pulses are applied to the base of TS907 via GR919. This transistor passes this pulse and discharges capacitors C914/15 via R935, GR918 and the collector-emitter junction of TS907.

Via R901, R932 and R933, capacitors C914/915 are re-charged and as soon as the voltage on the base of TS906 becomes positive, the flip-flop is reset to its initial position.

Adjustment of the lower scale value of 2.5% is effected by means of R933 and for 60 % by means of R932 of the RC circuit. In position 100 % SK8 short circuits the base so that only TS907 will be conductive. Diodes GR916 and 917 together with the appertaining voltage divider, supply a biasing voltage for the base potential of TS906. GR919 and 920 form a diode input for positive pulses which drive the base of TS907. GR920 prevents C911 from being charged.

The output pulses of the duty cycle switch drive the base of TS908 via R940/C919. This transistor operates as a switch and short circuits the step signal outside the duty cycle switching phase.

3. Ring counter

For the display of a certain number of curves (2 ... 8) a step signal is required, whose step difference determines the distance from one curve to another. For this, two requirements should be met, viz.:

stepwise switching until the number of pre-selected steps is obtained as well as the inclusion of resistance dividers which define the step voltages. These two processes are performed by the ring counter.

Each stage namely has a division ratio which has a certain value. This value determines the step voltage, which is different for each stage.

The basic circuit diagram of the ring counter is shown in Fig. 53, in which all switches are open. During operation only one of the switches is closed, so that the voltage divider circuit shown in Fig. 54 is obtained.

The step generator can operate in 3 different modes, viz.:

- Permanent display of recurrent characteristics (REP. FAM).
- Display of characteristics which are non-recurrent (SINGLE FAM.)
- Permanent display of a single curve with manual stepping (ONE CURVE).

These three modes are obtained by driving the ring counter accordingly (Fig. 55a, b, c).

- In switching mode REP. FAM. (Fig. 55a) the ring counter is driven directly by the trigger pulses from the pulse generator. Via C913 and switch SK7 a positive pulse is applied to the base of TS911. This

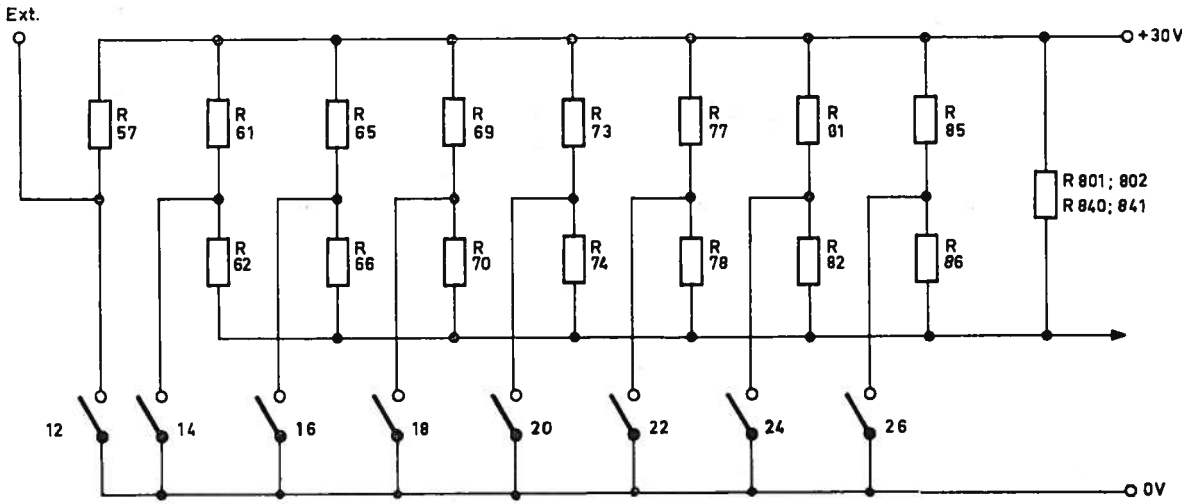

Fig. 53. Principle of the ring counter

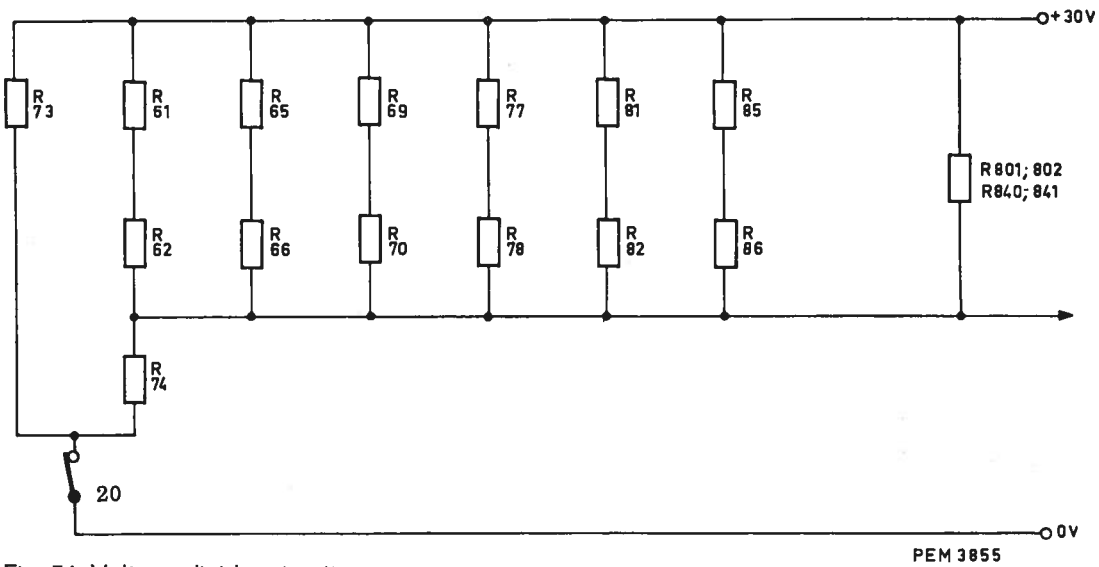

Fig. 54. Voltage-divider circuit

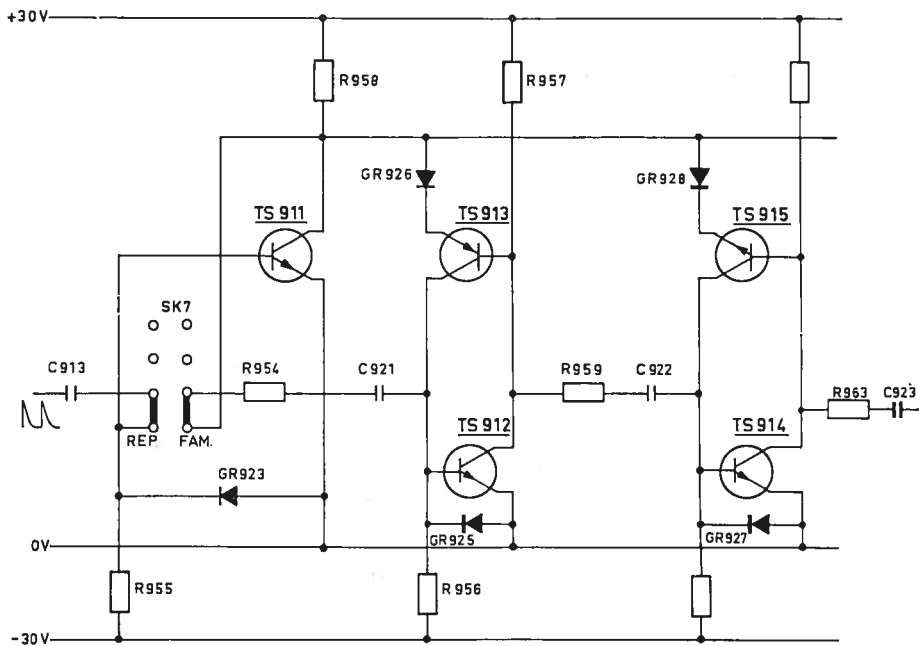

Fig. 55a. Switch position REP FAM

transistor becomes conductive and its collector voltage drops to practically zero. Capacitor C921 is now connected to approximately 0 V. After the pulse, TS911 is turned off again and via R958, R954 and C921 a current will flow through the base of TS912. This transistor changes over. As soon as the collector-emitter junction is conductive the base of TS913 becomes more negative and this transistor is also turned on.

Due to negative feedback from TS912 to TS913 and vice versa, this circuit will remain in the on-state until the emitter of TS913 becomes more negative than its base (this effect also occurs with thyristors (SCR) and silicon controlled switches (SCS)).

After the following pulse TS911 is turned on again and connects the collector potential to zero. TS913 and TS912 were conductive up to now and all the other transistors in the ring counter were blocked. Since the emitter of TS913 is connected to zero potential via diode GR926 memory TS912/913 will be released. During this switching process a current surge arises, which reaches the base of TS914 via R959 and C922. TS914 and TS915 change over and remain on until the next pulse.

In this way a further switching stage is connected in the ring counter after each pulse, till the number of stages selected with SK3 is attained. The relevant switch position of SK3 connects the output pulse to zero potential so that the pulse cannot switch on any more stages. The switching process then starts again with the first stage and in this way continuous switching from the first up to the selected number of stages is obtained.

b. In case of trigger mode "SINGLE FAM." the circuit is as shown in Fig. 55b.

The input pulses change over TS911, but the first ring counter stage does not receive a transfer pulse. Only when SK6 is depressed the base of TS912 receives a positive pulse so that stage TS912/TS913 changes over. Switching of the following stages is effected automatically until the last stage is reached and the switching process is completed. A new switching process cannot be started until button SK6 is depressed. In this way the process takes place only once when the button is depressed. Switching from one stage to another is further described in section a.

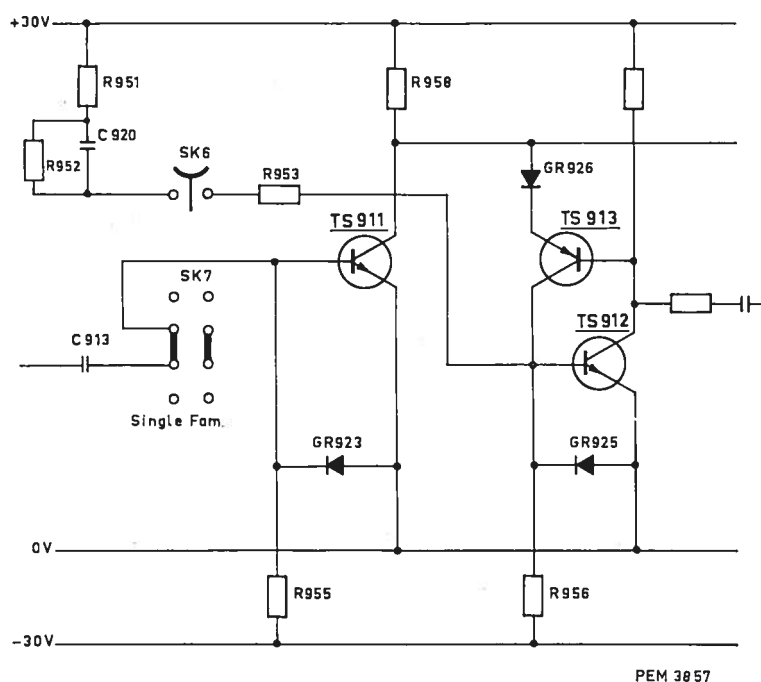

Fig. 55b. Switch position SINGLE FAM

c. In switch position "ONE CURVE" (Fig. 55c) switching-over of the ring counter is effected manually by means of button SK6. The input pulses are disconnected, so that triggering by the pulse generator is not possible. When button SK6 is depressed a positive current surge arises across F951/C920, which changes over TS911. After C920 has been charged the pulse

disappears, TS911 is turned off and drives TS912 into conduction via R954 and C921 and, via the feedback circuit, also TS913. Stage 1 retains this condition until the next pulse is applied. TS911 is turned on again by a new pulse, while TS912 and TS913 are already conductive. The memory of the PNP-NPN combination is released and via R959/C922 a new memory element becomes operative.

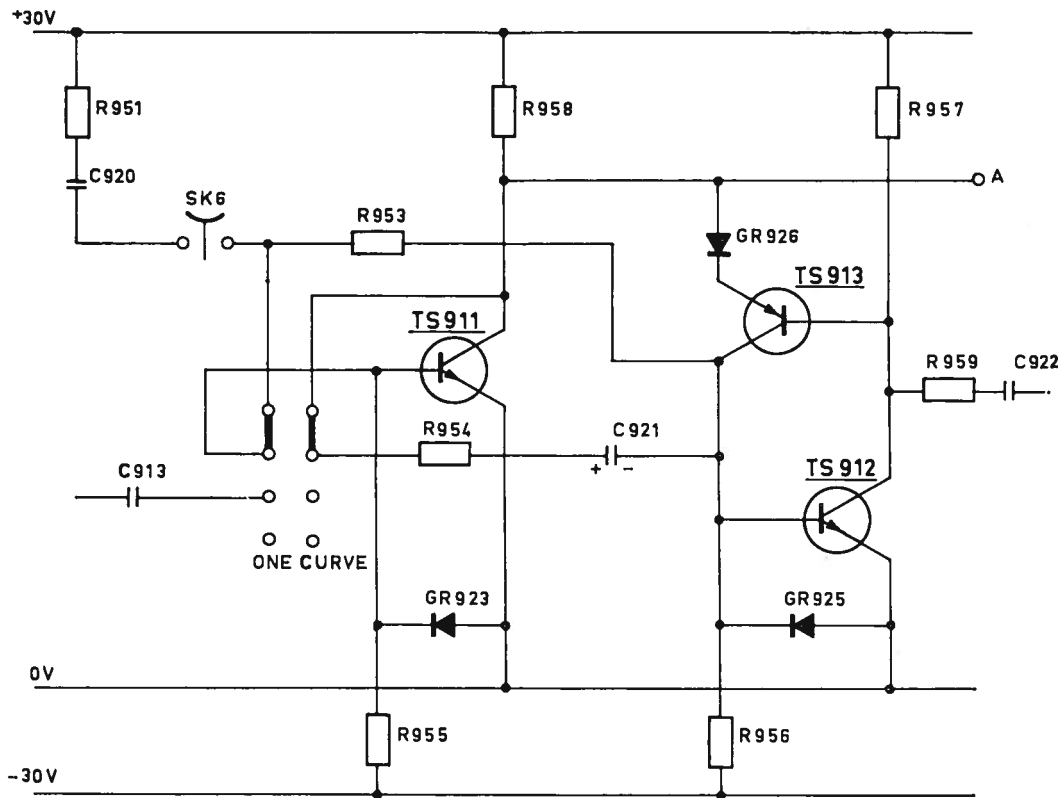

Fig. 55c. Switch position ONE CURVE

4. Amplifier (Fig. 56)

The output signal of the step generator is present on the base of TS801. This transistor operates as an impedance transformer which converts the step voltage into a constant step current of $100 \mu\text{A}$ per stage. Because the step signal — dependent on the function to be displayed — should be inverted, it is connected direct to the base of TS804 by means of a relay (RE801), or to the base of TS802. This transistor forms an inverter stage for the step signal which is then again applied to the difference amplifier. Moreover, the base potential of TS804 can be shifted within a certain range so that zero adjustment of the step signal is possible by means of control "ZERO". The base current of TS803 is varied by means of potentiometer R902. The collector of this transistor is connected to the base of TS804, so that the bias current at the input of the difference amplifier is thus determined.

The differential circuit with transistors TS804 and TS805 compares the step voltage across R810/R811 and R828 with the voltage on step switch R607 . . . 623 in the output circuit. The constant step voltage on TS804, which can be adjusted with R811, serves as a reference. In case of a difference TS805, which receives the drive signal via an impedance transformer,

drives the power amplifier so that the voltage is corrected in voltage divider R607 . . . 623 until the difference is eliminated. The step current adjusted with SK10 always remains constant independent of the resistance in the base circuit.

When the transistor under test is not current but voltage-driven (with a constant voltage from step to step), voltage division is effected by the 200-mA current stage. The power amplifier in this case operates in the same way as with a constant current of 200 mA, whereby this current flows through R623 (Fig. 57). Series resistors R601 . . . 606 are included with SK10 II+I.

The current from the 200-mA stage then causes a voltage drop across these resistors. In this way 6 voltage ranges are obtained for a step signal which can be selected by means of SK10.

In case of voltage drive, series resistors R501 . . . R523 should be selected so that the voltage-drive characteristic is not lost. At high resistance values this property may be employed for current drive (e.g. $0.1 \text{ mV/step } 1 \text{ M}\Omega = 0.1 \mu\text{A/step}$). In switch position 0 resistors R501 . . . R523 can also be switched in so that characteristics can be displayed with resistance termination of the base circuit (I_{CER}).

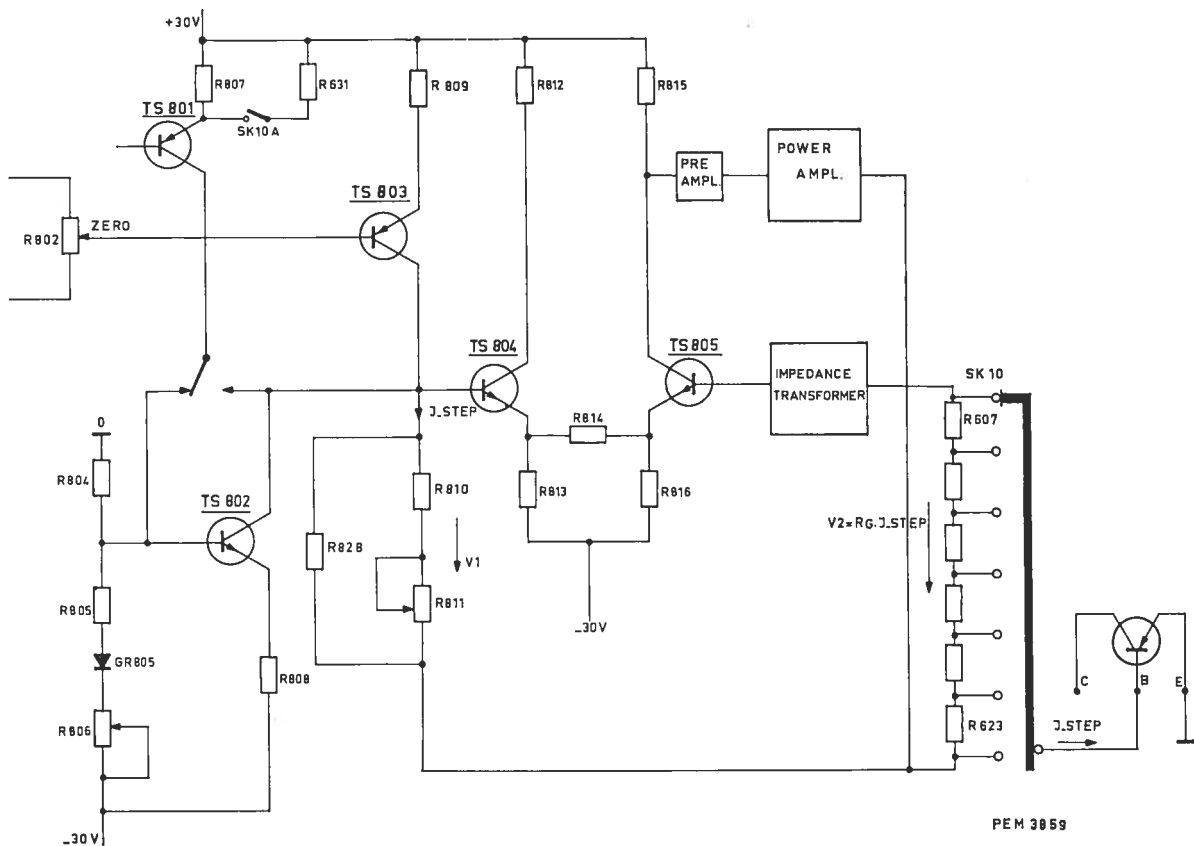

PEM 3859

Fig. 56. Amplifier

5. Power amplifier

As appears from the description under point 4, the current or voltage value of the step signal is determined by a difference amplifier. This difference amplifier supplies the control signal for the power amplifier. The latter consists of pre-amplifier TS806, emitter-follower TS807 and the final stage with TS808... TS811. TS808 and TS809 serve as a driver stage for the final stage with TS810 and TS811 which is a class AB push-pull output stage. Diodes GR801 and 802 provide the potential difference by which the d.c. setting of the output stage is determined. The output stage is supplied by a separate voltage source of +18 V/0/-18 V which is delivered by full-wave rectifier GR1 and smoothed by C703 and C704.

C. DISPLAY SECTION

The display section serves for displaying the current and voltage relations in the transistor under test. By means of 2 mode and range switches, SK13 and SK16,

it is possible to select the horizontal and vertical deflection coefficients for displaying the characteristics and selecting the display method. The switches enable selection of various modes and moreover a position "EXT" has been provided for connection of an external signal.

Horizontal deflection (SK 13):

The horizontal deflection determines the collector voltage in 15 ranges. The 3 upper ranges (100, 200 and 500 V/cm) serve for measuring breakdown voltages (H.T. source). These three voltage ranges can be reduced by a factor 10 with push-button x.1 (SK 13A); when this button is depressed, parallel resistor R385 is disconnected (Fig. 60). Switch position " " serves for displaying the step signal whereby the range value selected with SK10 should be employed for reading the signal amplitude. For displaying the base voltage, e.g. as a function of I_B , 4 ranges are available from 10... 100 mV/cm.

External connection: 10 mV/cm, 1 M Ω .

Vertical deflection (SK16):

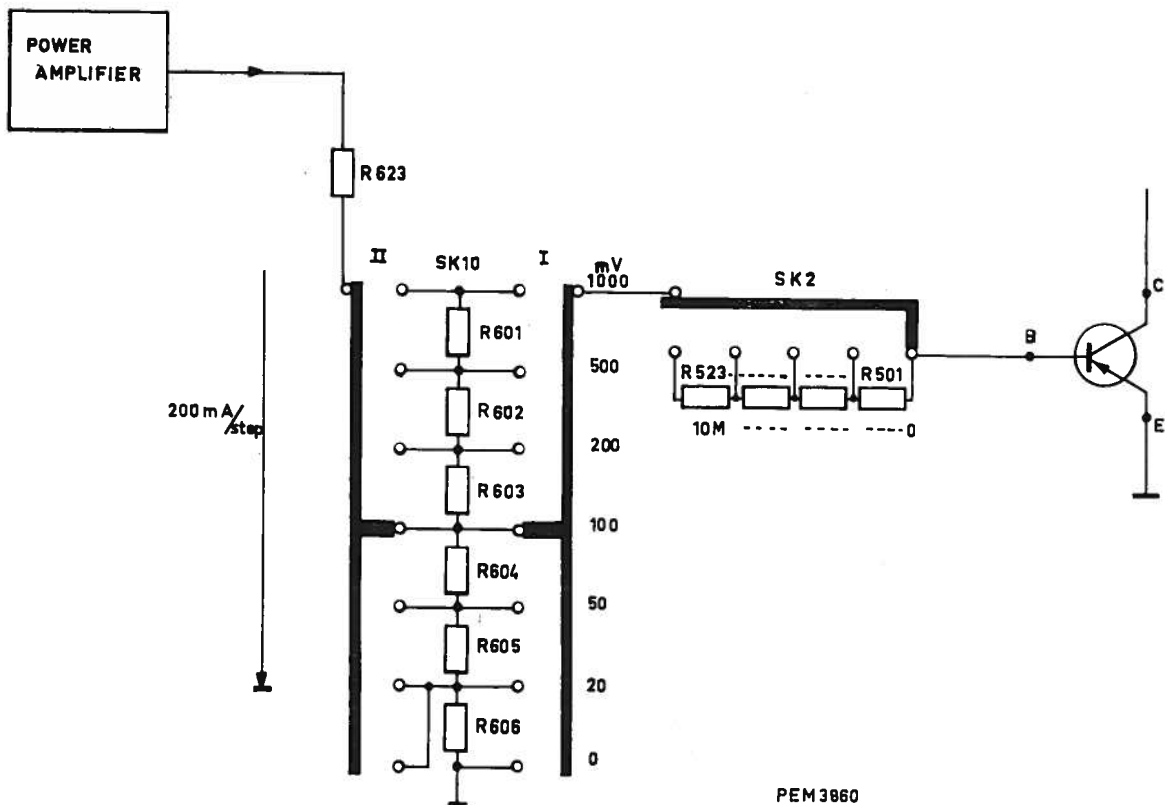

PEM 3860

Fig. 57. Voltage drive

The vertical deflection operates in the same way as the horizontal deflection (SK13) and serves for range selection of the collector current. From $10\ \mu\text{A}$ to $5\ \text{A/cm}$ the collector current can be sub-divided into 18 ranges. Moreover, it can be extended $\times 0.5$ and $\times 5$ in downward and upward direction. The sensitivity of the 10 lowest ranges can moreover be increased by a factor 1000, so that the indications become nA/cm instead of $\mu\text{A/cm}$. This sensitivity is only employed for leakage current measurements; changing over takes place by means of slide switch SK9. Switch position "┌" has the same function as with SK13, and the same applies to the base voltage

and position "EXT". In this way different display methods are possible by means of SK14 and SK15.

1. Circuit for I_C and V_{CE} measurements

The measuring circuit for displaying I_C/V_{CE} curves (as a function of the base current or voltage) is based on the diagram shown in Fig. 58. The collector-emitter voltage applied to the transistor under test is determined by SK13 and applied to the c.r.t. via the horizontal amplifier. The measuring ranges can be selected by means of the voltage divider consisting of R332... R344, and the corresponding step voltage is applied to one input of difference amplifier X.

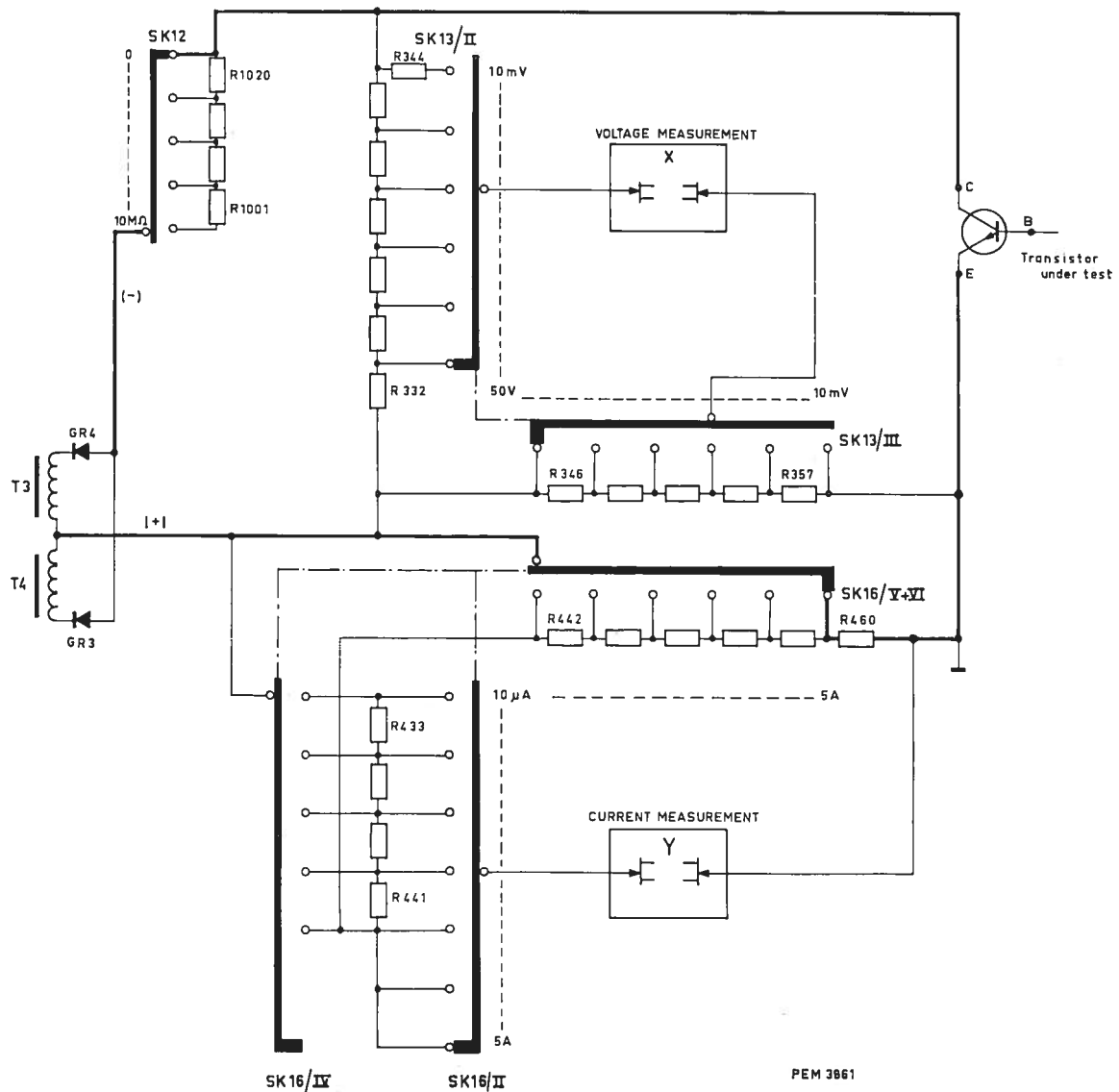

Fig. 58. Collector-current circuit

PEM 3861

The other side of the difference amplifier is connected to attenuator R346...R357 which is also operated by means of SK13. The combination of SK13/II and SK13/III enables accurate determination of the actual voltage present on the transistor by determining the loads presented by the resistors of SK13/II. Measurement of the current flowing through the transistor is effected by means of range switch SK16/V+VI and the corresponding voltage divider. Resistors R442...R460 are the measuring resistors for the current stages. The step attenuator coupled with SK16/V+VI (III+IV) is only switched in for the "nA" ranges. The voltage drop across shunt resistors R442...R460 is applied to difference amplifier Y via SK16/II or IV, one input of which is connected to the measuring potential and the other to earth U4/C5.

2. Circuit for V_{BE} measurements

For curve display, with V_{BE} signal in the horizontal or vertical direction, e.g. $I_C = f(V_{BE})$ or $V_{BE} = f(I_C)$, the measurement is based on the principle shown in the diagram of Fig. 59. The difference amplifiers for horizontal or vertical deflection are connected to the base-emitter circuit of the semi-conductor. The step signal from SK10 is determined by this amplifier and applied to the relevant attenuator. The desired display range

can be selected by means of switch SK13/I or SK16/I. The corresponding voltage component then drives the output amplifier. The collector-emitter circuit is supplied by the half-wave voltage obtained from TS +T4 and GR1...4.

3. Circuit for breakdown voltage and leakage current measurements (Fig. 60).

Fos testing 2-pole semi-conductors as regards breakdown voltage or leakage current, a half-wave voltage is generated by means of continuously variable transformer T1, H.T. transformer T1101 and GR1101 and 1102.

This voltage is applied to socket BU5 via switch contact DS1.

Voltage measurement is effected by means of the voltage divider consisting of resistors R1101...1103 and R329...331. By means of switch SK13/II one of the three voltage stages is applied to the horizontal amplifier.

Via socket BU4 the current through the semi-conductor is determined. This measuring circuit is connected to earth via step switch SK16/IV, II, R433...R441 and R442...R450.

The voltage arising across the resistance selected with range switch SK16 is applied to the input of the verti-

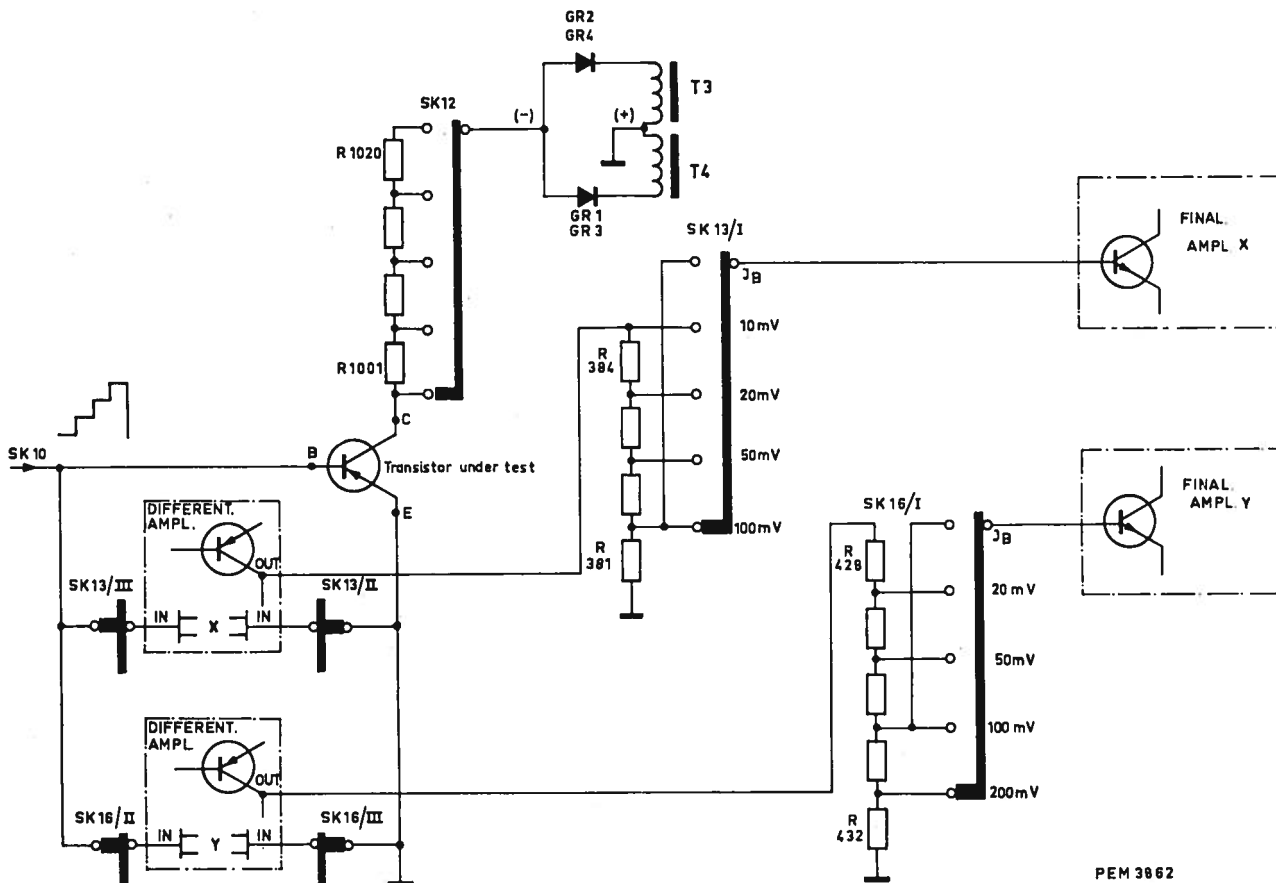

PEM 38 62

Fig. 59. Measuring circuit for V_{BE} measurement

cal amplifier and thus to the vertical deflection of the c.r.t.

Slide switch SK9 for switching on the h.t. generator, moreover serves for changing over from μA to nA ranges. In position " μA " of SK9 resistors R442...R450 are included, and in position "nA" R433...R441 are moreover included in series with R442...R450. Dependent on the selected range a voltage drop will arise across the included resistors which is proportional to the leakage current flowing through the semi-conductor under test.

4. Difference amplifier for X and Y deflection

The preset drive signal is amplified or changed by the semi-conductor under test. This signal is applied to the X and Y amplifiers dependent on the selected mode

and range, which apply proportional voltages to the horizontal and vertical deflection units of the c.r.t. These output signals are determined and amplified by 2 independent difference amplifiers. The following description applies to the X amplifier which functions identically to the Y amplifier.

The input stage consists of two field-effect transistors which operate as impedance transformer and amplifier. The input signal is applied to the first gate and the second gate serves for adjusting the d.c. balance with R303 or R319. The working points of these transistors are automatically adjusted by means of TS303 and TS304 which are controlled by the constant voltage drop on zener diodes GR304 and 305 in case of a varying drain current.

The output signal on the drain connection of TS301

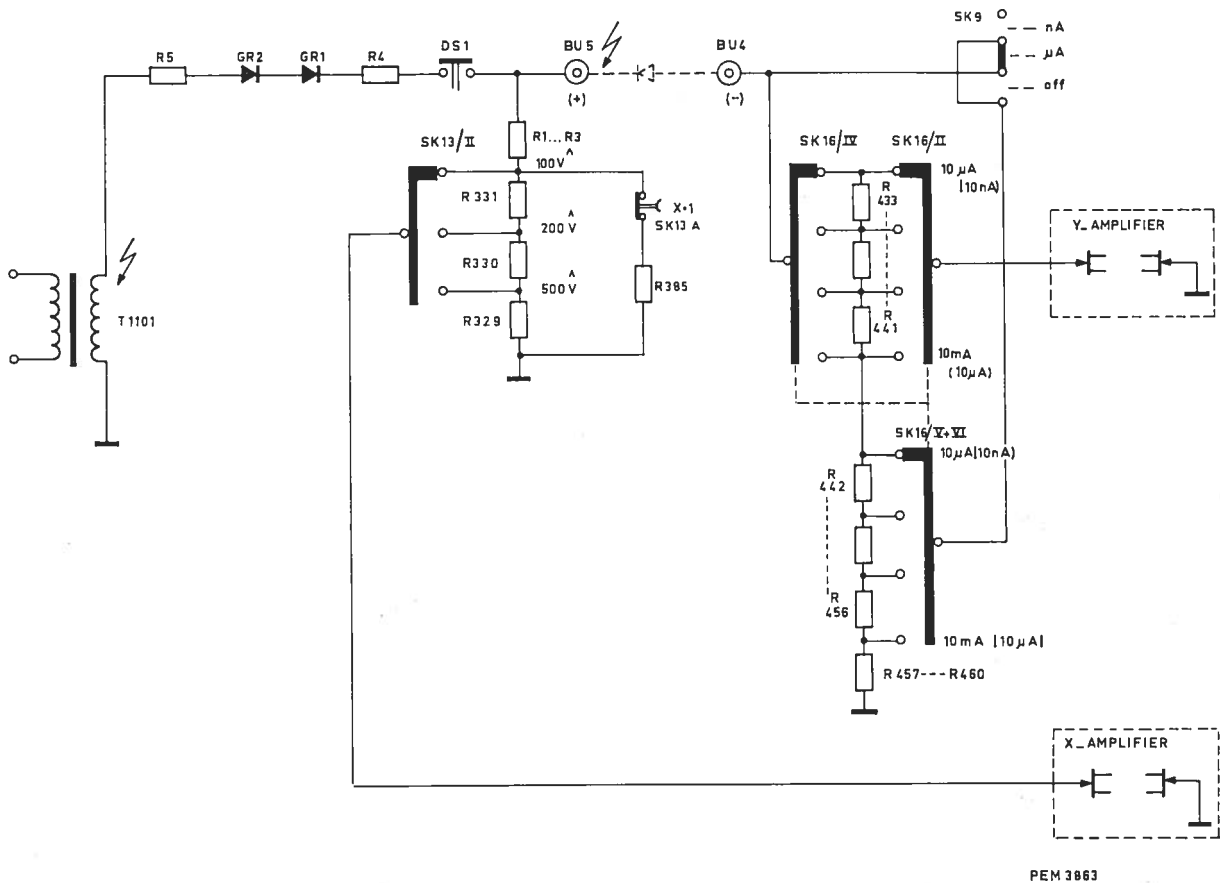

Fig. 60. Measuring circuit for breakdown-voltage and leakage-current measurements

and TS306 drives the following difference stage which consists of TS302 and TS305.

The control voltage for TS304 is derived from their emitter currents and TS304 in turn serves as current source for TS301 and TS306.

The output signal of the difference amplifier drives TS307.

The amplified drive signal is present on the collector of the latter and is applied to the output amplifier via range selector SK13. It moreover closes the negative feedback circuit via R322, R317, R310, R34.

Adjustment as parallel circuit to R310 and R317 is effected with R311 in series with R318. On unit U3A the +50 mV calibration voltage is derived from the +30 V by means of a voltage divider. The voltage divider consists of resistors R370...372 which is adjusted by means of R373. Contrary to the X amplifier the Y amplifier has three gain factors which are obtained by changing the negative feedback circuit. These three changes can be selected by means of SK17 and extend the measuring ranges (with respect to 1) 0.5 and 5 in both directions. In position x1 resistors R407, R411 and R418 are included, in position x5 all resistors are switched out, and in position x5 only R411 and R418 are switched in.

5. Output amplifiers X and Y deflection

The output signals from the difference amplifiers drive the relevant output amplifiers via range selectors SK13 and SK16. These amplifiers consist of an input stage, a differential circuit and a two-stage push-pull output stage (Fig. 61). The negative feedback voltage from the differential amplifier is taken from a resistor which is connected in series with the deflection coil. The current is determined by means of this resistor. The input signal consequently causes an output current through the deflection coil, which is exactly proportional to the input signal. Diodes GR103/104 form a voltage threshold, which determines the working points of TS105 and 106, together with R121 + R122. R188 serves for balancing the working points of the limiter diodes GR101 and 102 and RC element R110/C102 increases the stability of the output amplifier. Potentiometer R157 in the Y output amplifier and R311 in the X pre-amplifier serve for gain control.

6. Brightness control

The brightness control of the electron beam serves the following tasks:

- a. At high sweep speeds the beam current intensity is increased thus ensuring uniform display of the oscilloscope trace.
- b. Brightness control is also effected by means of the duty cycle generator which also increases the brightness during the written part of the cycle.

The function mentioned under point a is performed by RC elements R174/176 and C162 plus R173/175 and C163. These RC elements are frequency dependent so that at higher frequencies the beam current intensity increases with respect to the low frequencies.

Dependent on the position of the picture on the screen the deflection direction should be determined. This is effected by diodes GR161...164. In case of a bright-up TS161 inverts the phase of the voltage obtained from GR161...164. To transistor TS162 three information signals are applied: via R169 the positive cycle, via GR163/164 the negative cycle and via R161 the

duty cycle. The collector of TS162 is connected to the first grid of B1. In case of a positive control voltage the beam current intensity increases, or the anode current, and at a more negative voltage the intensity is reduced.

In order to ensure that during the flyback of the step signal no or only a weak display is obtained, the duty cycle generator causes blanking of the electron beam. When TS907 is in the off state the base of TS162 is connected to a positive voltage via R945 and R161. TS162 is turned off and the first grid of B1 receives a negative potential via R163 so that the beam current of the c.r.t. is small during this period.

Circuit to prevent burning in of the screen (unit 1A; refer to Fig. 114 and 115)

A signal which is a measure for the deflection amplitude is taken from deflection coils Lx and Ly (U1/5 and U1/18). Via R191 and R192 this signal controls TS191. C191 provides a damping for the higher frequencies so that only L.F. signals can reach the base of TS191. The amplified a.c. signal is rectified by GR191 and GR192 and smoothed by C194. The amplitude of the d.c. signal is limited by GR193. After this the signal is applied to the base of TS162 via R196 (or R195), where it influences the brightness control.

When a signal (X or Y direction) is displayed, a control signal arises which, via R196 (R195), drives TS162 in such way that the control voltage of B1/G1 is reduced. This results in a higher brightness of the trace on the screen when it is longer than approx. 3 cm in either direction.

As soon as the deflection (X or Y direction or both) has a certain value, the output voltage on U1A/1 is stabilised by the zener diode, so that the beam current remains constant.

H.T. generator U2

The H.T. generator (U2) supplies the acceleration voltage of +4.5 kV for the c.r.t. and the +300-V focusing voltage.

Basically the generator consists of a regulated oscillator, which derives the two voltages from the two isolated secondary windings. These voltages are rectified in a doubler circuit.

Working principle:

The tuned circuit of the oscillator is formed by the inductance and stray capacitance of the coil. The collector-emitter current of switching transistor TS203 flows through windings S1 and S2 of T201. This transistor is controlled by TS201 and TS202, the control voltage for TS202 being derived from the +300-V voltage by means of a voltage divider. With R209 the base-emitter voltage is adjusted so that the focusing voltage is +300 V.

Regulation:

When the +300-V voltage decreases the base-emitter voltage of TS202 decreases and thus the collector-emitter current. The base of TS201 now becomes more positive and the collector-emitter current decreases. The base potential of TS203 is consequently shifted towards the negative side and the base-emitter voltage of this transistor increases. As a result of this the collector-emitter current of TS203 increases and thus the current through windings S1 and S2 of T201. The secondary voltage in winding S4 increases until the +300-V output voltage is attained and the stabilised condition is obtained.

IX. Disassembly

CAUTION

In this instrument high tensions of 500 Vp, 3 kVp and 4.5 kVp are generated. Therefore due care should be taken when working on a switched-on instrument.

A. CABINET

Top panel:

Loosen the two upper screws at the rear of the instrument (Fig. 3) by giving them a quarter turn. The panel can then be slid out to the rear.

Bottom panel:

Remove the corresponding screws from the bottom plate and remove the tilting bracket by pressing the ends of the bracket together.

Rear panel:

First remove the top and bottom panels, then remove the three screws on each side. Unsolder the earthing connection or unscrew the soldering tag, if the rear panel should be completely removed. Remove the 4 fixing screws; the panel can then be taken out.

B. CRT

The CRT should be replaced with due care so that undesired mechanical tensions are avoided. It should, moreover, be taken into account that the external dimensions of the CRT may vary. Therefore, when replacing the tube strictly adhere to the following instructions.

Removing the CRT:

- Remove the top, bottom and side plates as well as the rear panel.
- Pull out the tube socket and detach the EHT cable from the tube by slightly compressing the clips.

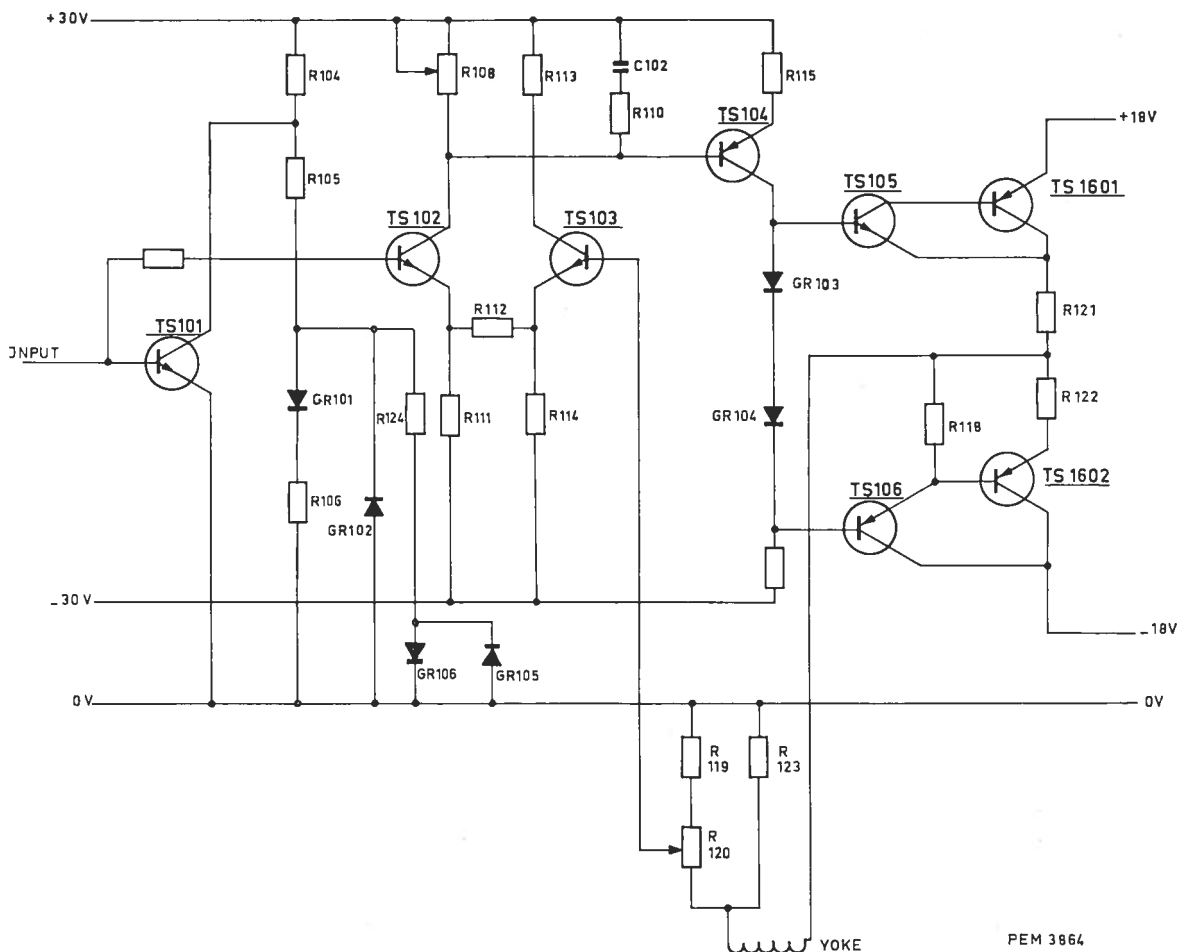

Fig. 61. X-Power amplifier

- Remove the bezel (remove the 4 knurled nuts).
- Remove the screw of the bracket at the rear of the deflection unit.
- Slightly loosen the 4 nuts on the threaded studs (on which the bezel was fitted) at the front of the instrument (do not remove them).
- Loosen screw M (Fig. 62) until the tensioning strip is loose.
- The tube can now be removed in forward direction after carefully pushing it out of the corner pieces.

Removing the deflection unit:

- Unsolder the connection wires of the deflection coil at the relevant soldering tags.

IMPORTANT:

Before unsoldering first make a note of the wire colours to prevent interchanging.

- Remove the two fixing screws L (Fig. 62) and take out the complete holder with deflection unit.
- Remove screw K (Fig. 63).

Mounting the deflection unit on the picture tube:

- Slide the deflection unit on the tube neck in the correct position (the screw of bracket down; the correction magnets should be situated on the broad side of the tube).
- Slide the mumetal jacket about 5 mm into the deflection unit.
- Push the deflection coil on the tube, align it and slightly tighten screw K (so that the tube can still be turned in the unit).

Mounting the CRT:

- Push the tube into the cornerpieces, mind the correct position. It should be possible to shift the 4 cornerpieces. The rubber supports should be correctly positioned.
- Fit the tensioning strip but do not yet tighten the screw.
- Slightly tighten the four nuts on the threaded studs so that the cornerpieces can still be shifted.
- Position the tube symmetrically in the front frame; the screen should be flush with the front plate.
- Tighten screw M of the tensioning strip (Fig. 62).

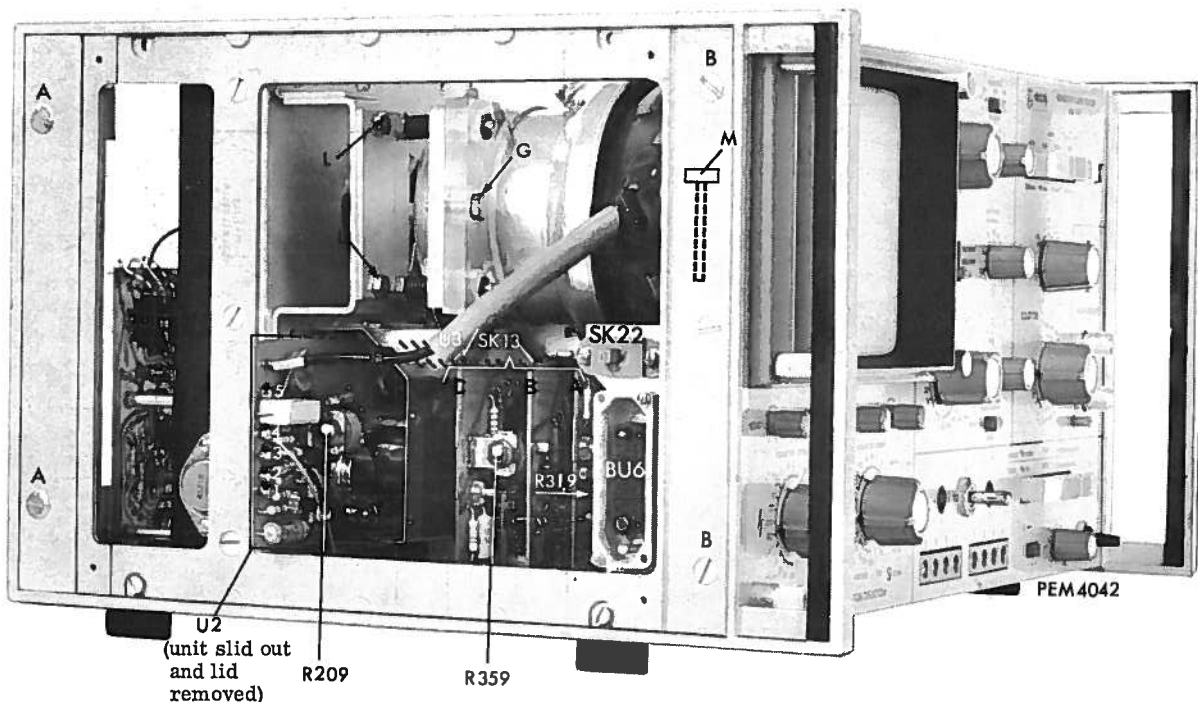

Fig. 62. Side view (left)

- Re-align the tube with respect to the front frame and completely tighten the four nuts of the threaded studs (the screen should now be exactly flush with the front plate).
- Fit the yoke holder, by means of the two screws L (Fig. 62) and make sure that the plexiglass support properly fits against the yoke.
- Align the plexiglass support in the centre position and fix it by means of screw G (Fig. 62).
- Tension the plexiglass support as much as possible.

Accurately align the yoke; it should be slid forward as far as possible.

Secure the bracket on the plexiglass support with screw G (Fig. 62). The springs should now press the yoke against the picture tube.

- Connect the deflection unit (mind the colours of the wires), fit the tube socket and the EHT connection.
- Fit the bezel.
- Adjust the yoke and the picture tube according to the instructions of chapter XI.F.2.

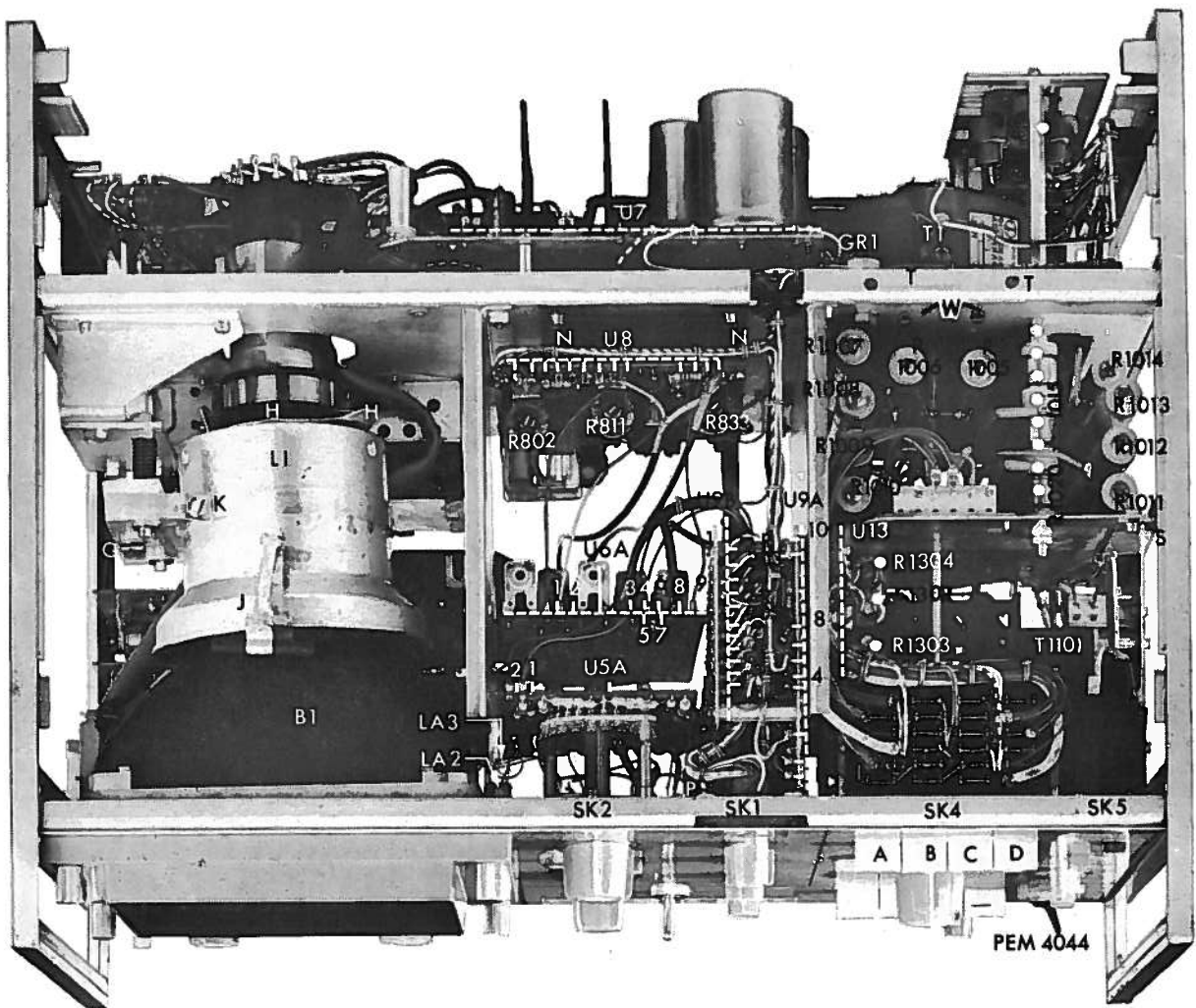

Fig. 63. Top view

C. REMOVING THE SUB-UNITS

When removing the sub-units be careful when soldering connection wires and short connections. Make sure that no wires are interchanged or skipped. Make a wiring list and note the wire colours!

1. Unit U1

This unit is located at the rear of the instrument and is easily accessible after removal of the rear panel.

2. Unit U2 (Fig. 65)

Remove the left-hand side panel and loosen 2 screws E (Fig. 64). The cover can now be removed and the EHT unit can be pulled out.

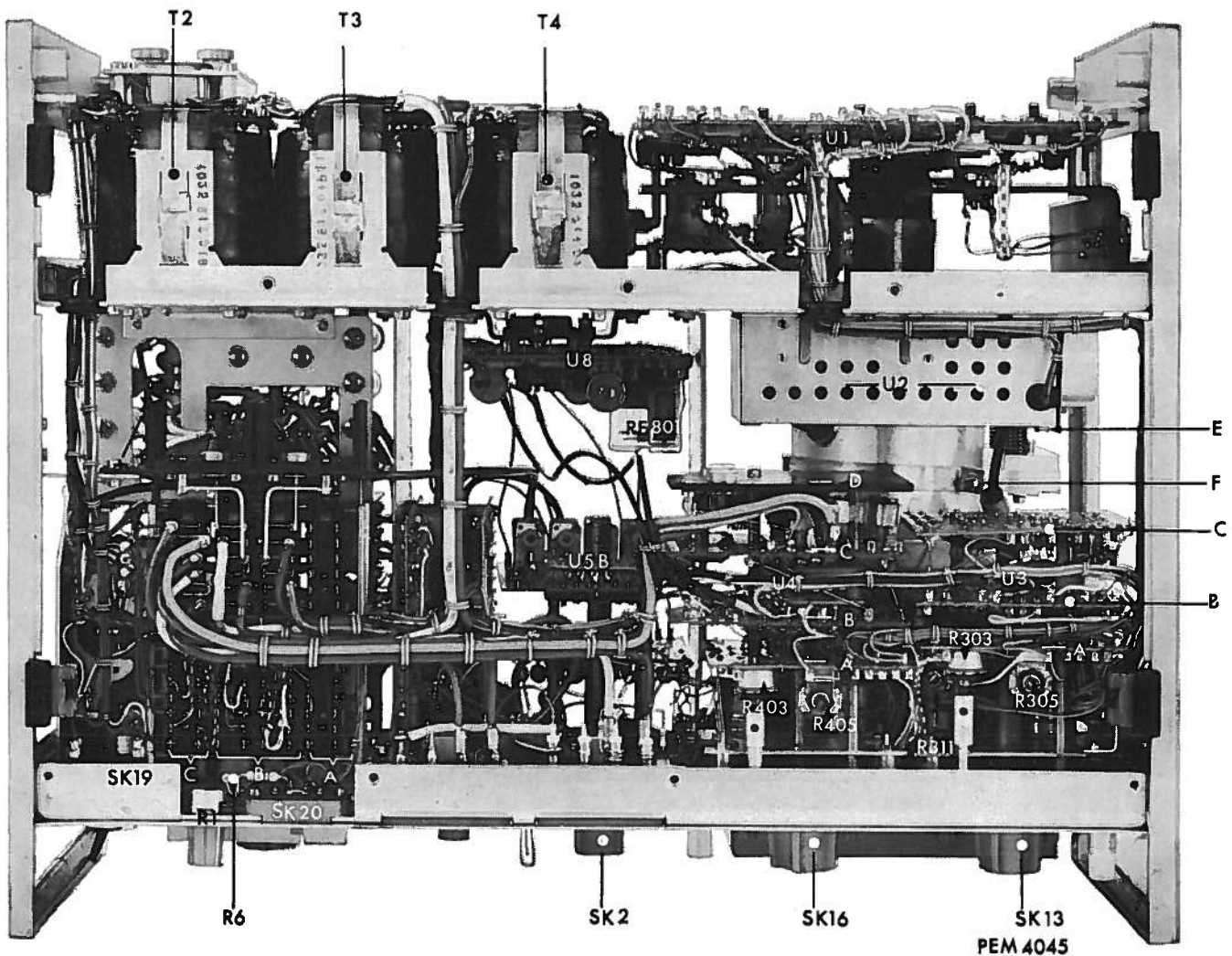

Fig. 64. Bottom view

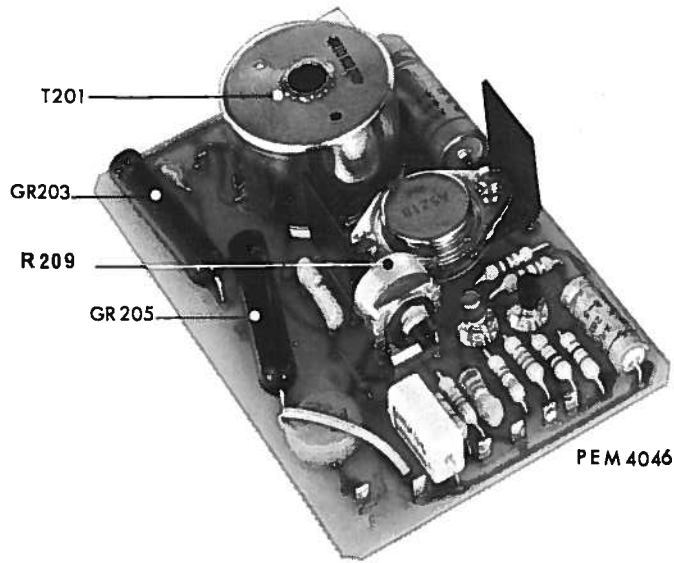

Fig. 65. H.T. unit U2 (supply for C.R.T.), taken off

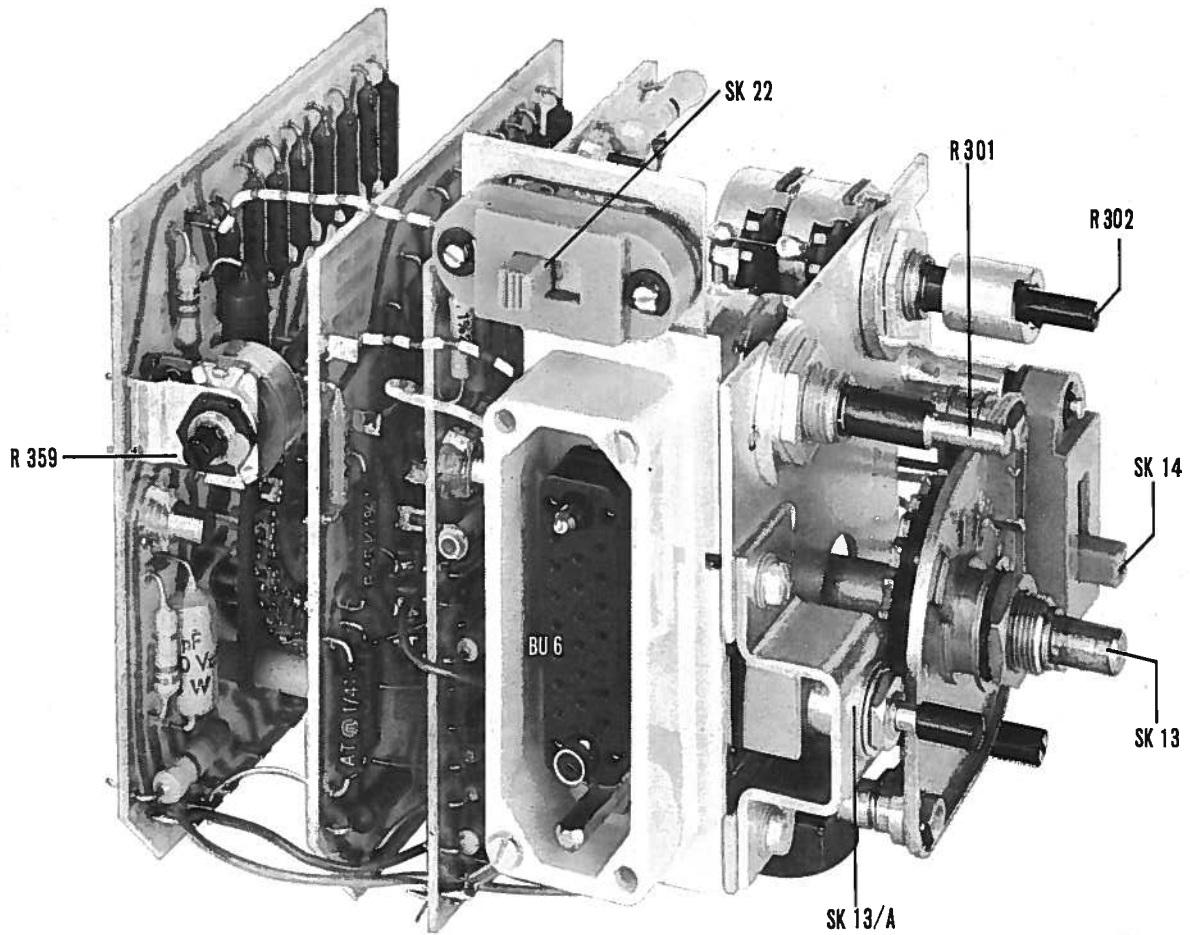

Fig. 66. X-Deflection unit U3, taken off

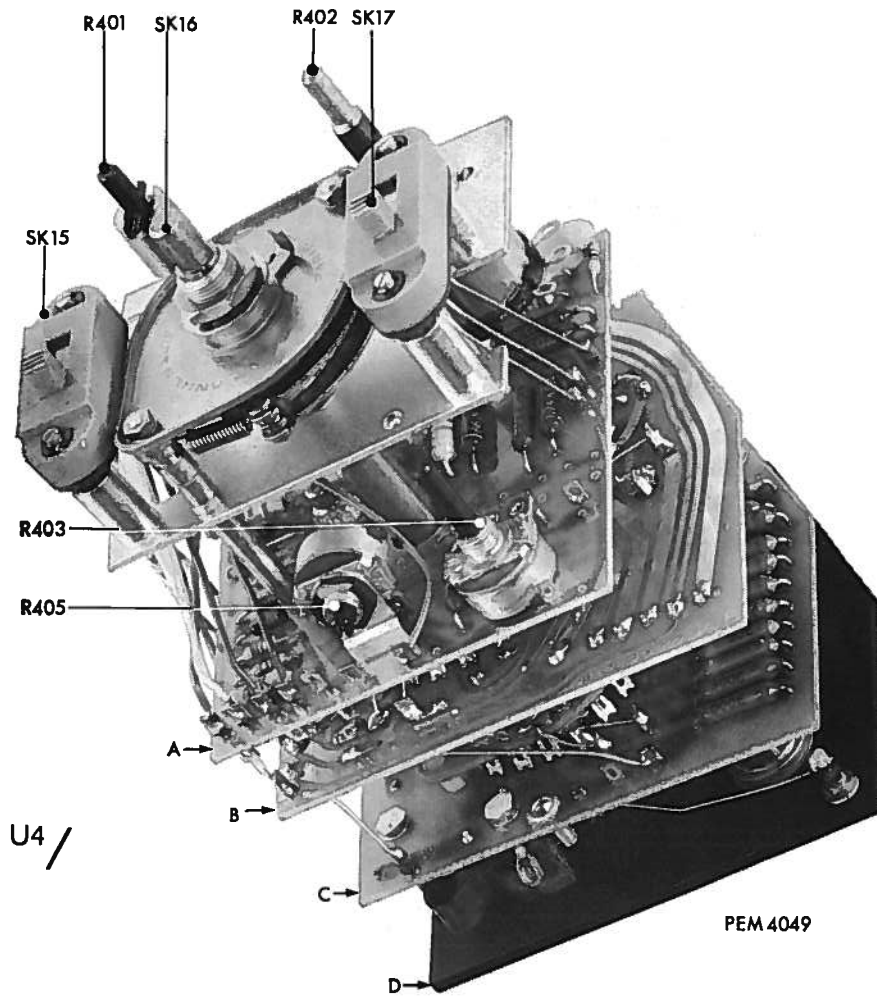

Fig. 67. Y-Deflection unit U4, taken off

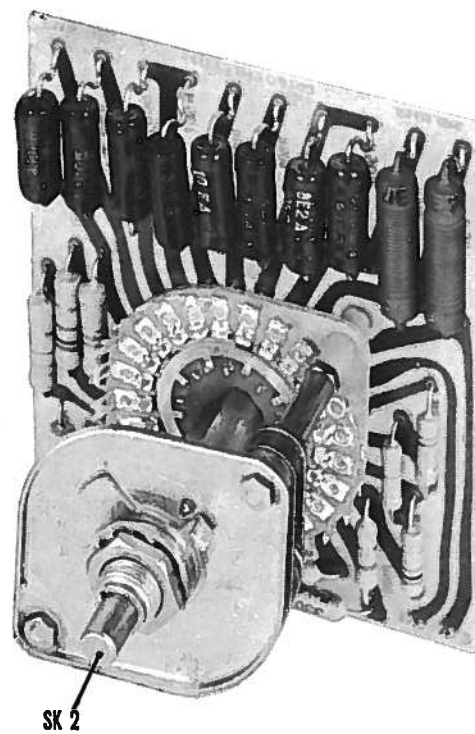

Fig. 68. Base-resistor unit U5, taken off

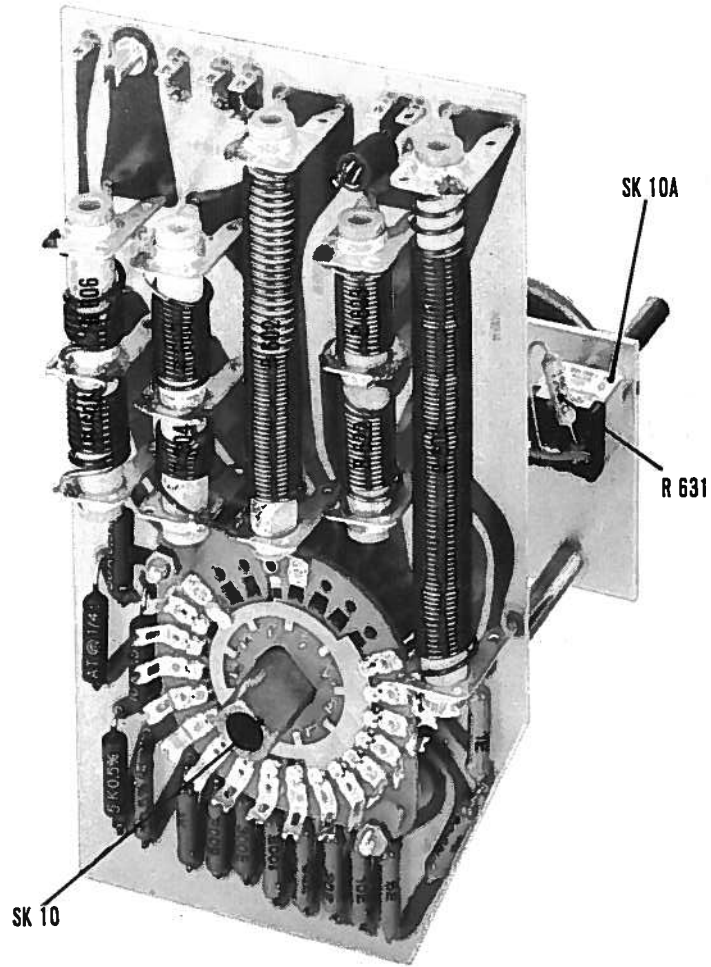

Fig. 69. Shunt unit U6, taken off

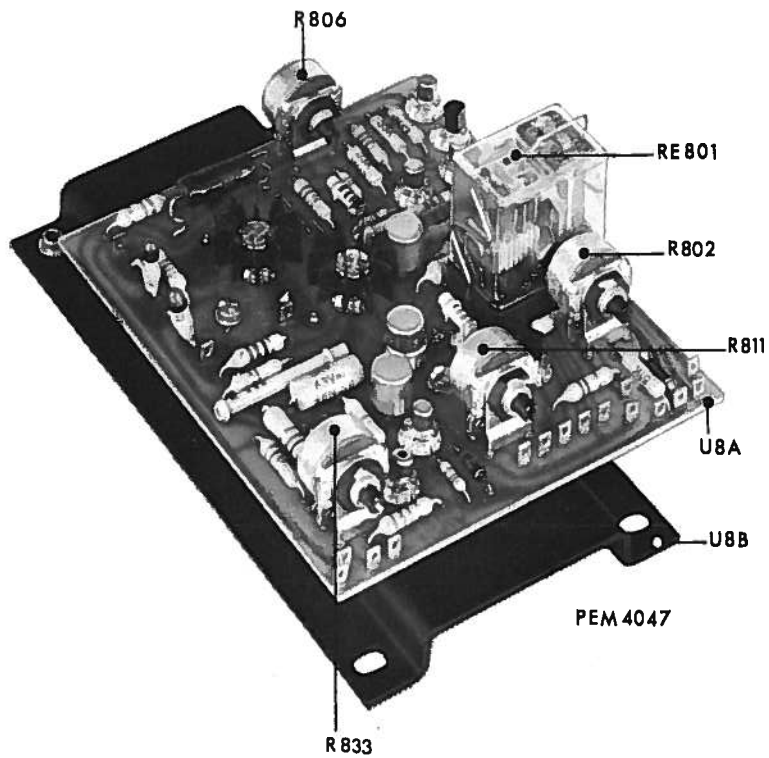

Fig. 70. Final-amplifier unit U8, taken off

3. Units U3, U4, U5 and U6 (Fig. 66, 67, 68, 69)

These units are centrally fixed. Remove the knobs, loosen the central fixing nuts, and unsolder the relevant connection wires.

Remove the bottom plate, the top plate and, if necessary, the left-hand side panel.

4. Unit U7

Remove the rear panel.

The unit is then readily accessible (4 fixing screws).

5. Unit U8 (Fig. 70)

Remove the rear panel. Remove 2 screws N (Fig. 63) and loosen 2 screws O. Unsolder the connection wires. When the unit is slightly pushed down, the screws can be removed from the bayonet holes.

6. Unit U9 (Fig. 72)

Remove the top plate, and then remove unit U5. Remove the knobs, the fixing nuts of SK3, SK8 and R902 as well as the knurled nut of SK6. Remove screw P (Fig. 63) and loosen screw Q (Fig. 71). Unsolder the wires, slide the unit backwards and take it out.

7. Unit U10 (Fig. 74)

Remove the bottom plate, the top plate and the rear panel. Loosen fixing nut R (Fig. 73) and pull out the spindle and knob of T1. Loosen the spindle coupling of SK12 (accessible from the top) and pull out the spindle. Remove the two screws T (Fig. 63) at the base plate of U10 and loosen screws S (Fig. 63). Unsolder the connection wires and lift out the units.

8. Unit U11 (Fig. 75)

Remove the top plate and the left-hand side plate.

Remove three screws U (Fig. 71) as well as screws S (Fig. 63) and take out the angle support.

Remove the two screws V (Fig. 71) the EHT unit can now be taken out.

9. Unit U12 (Fig. 76)

Remove the bottom plate and unscrew the knurled nut of SK18. The complete socket and switch unit can now be removed.

Remove the top plate. Loosen the fixing clips and take out the printed circuit board.

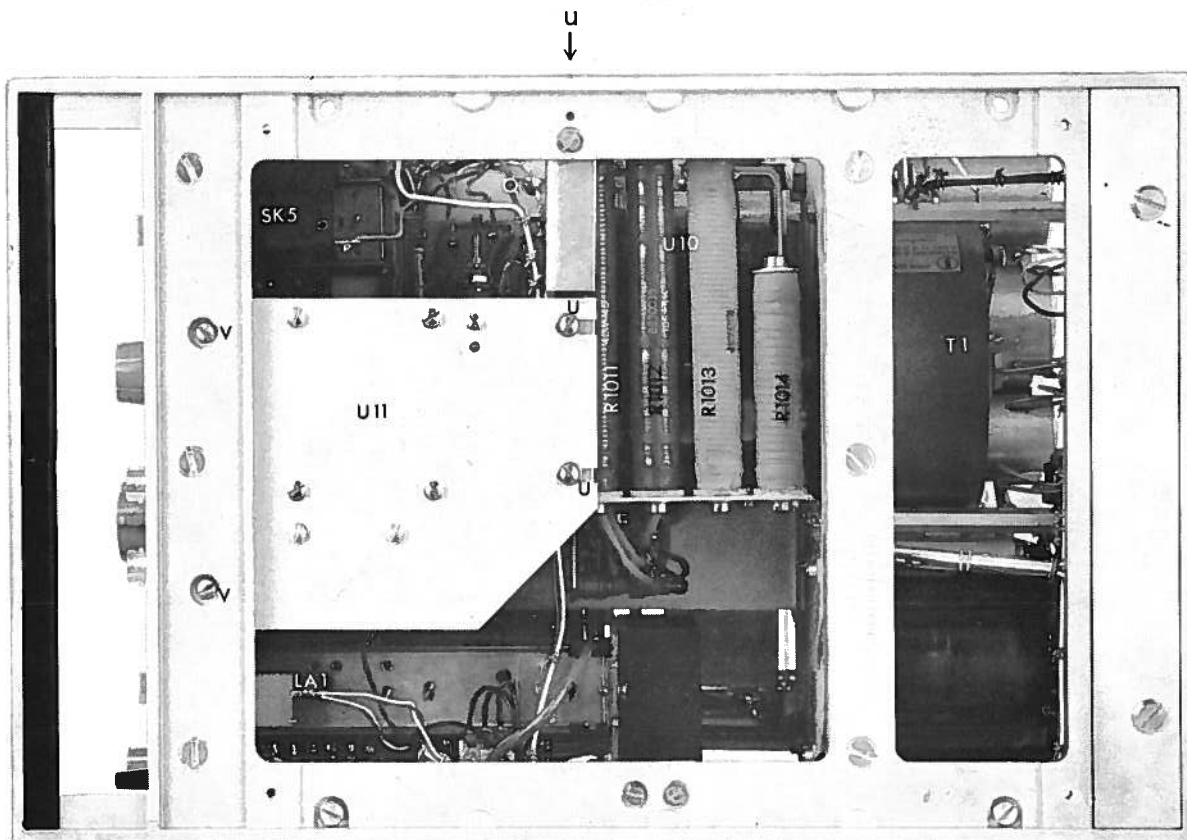

Fig. 71. Side view right

PEM4050

D. REMOVING COMPONENTS

If components are to be replaced which are located in one of the sub-units, it will generally be necessary to disassemble the relevant unit. The components can then be easily replaced.

1. Variable transformer T1

Remove the top-panel, the cover-plate of the mains-fuses and loosen the mounting plate which has been fitted with the three screws. Remove screws Y (Fig. 63). Loosen tightening nut R (Fig. 73) and pull out the spindle of T1. Unsolder the connection wires of T1. Loosen the two hexagon screws W (Fig. 63) by means of a spanner (7 mm). The transformer can now

be slightly pushed up and the screws can be removed through the bayonet holes, after which the transformer can be lifted out of the instrument. Before mounting the new transformer, fit the soldering tags and remove the stopping cams on the front of the transformer. The front of the transformer should be fitted completely against the mounting plate.

2. Push-button units SK4 (Fig. 77)

Remove the top plate. Remove the two screws at the side of the push-button unit and unsolder the connection cables.

3. Push-button unit SK19 (Fig. 77)

Remove the bottom plate. Remove the fixing screws on either side and also remove screw X (Fig. 64).

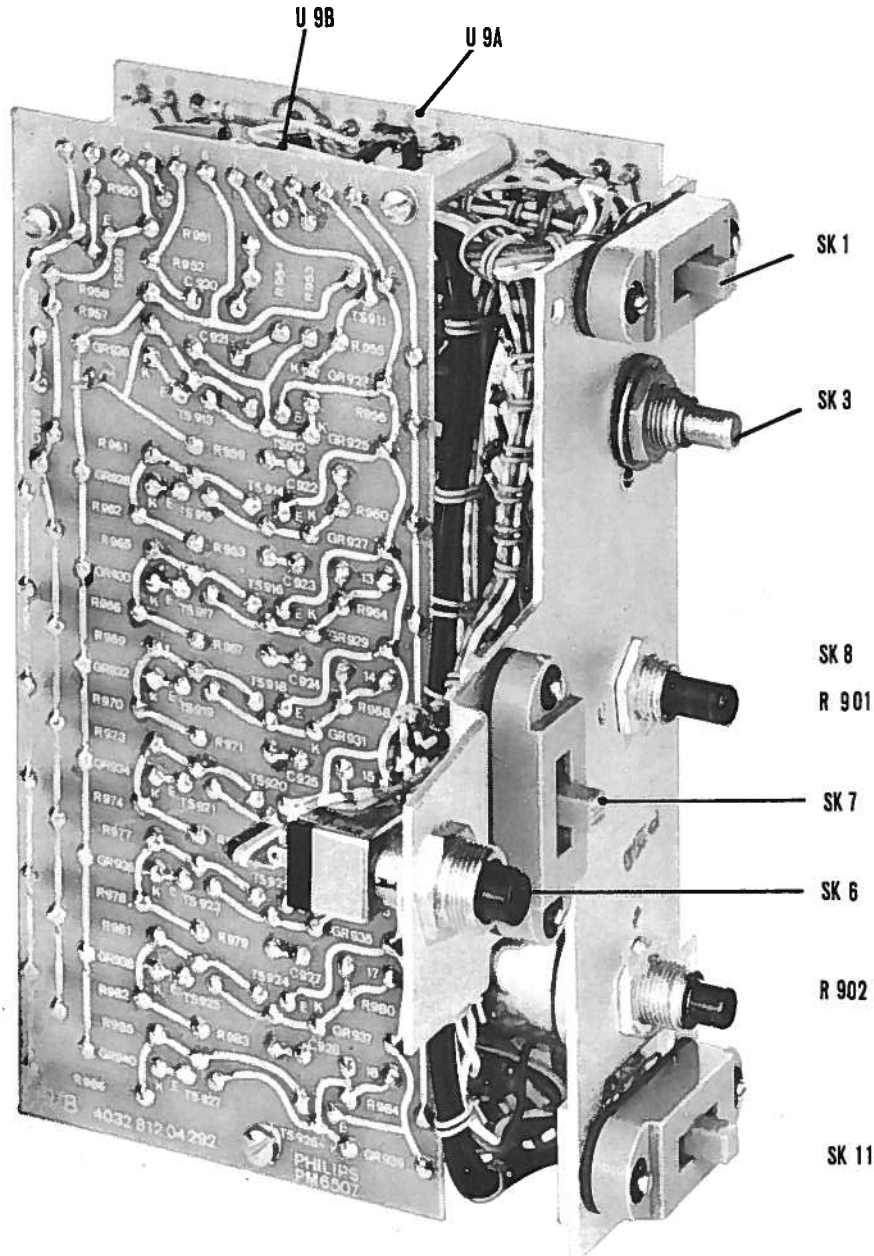

Fig. 72. Step generator U9, taken off

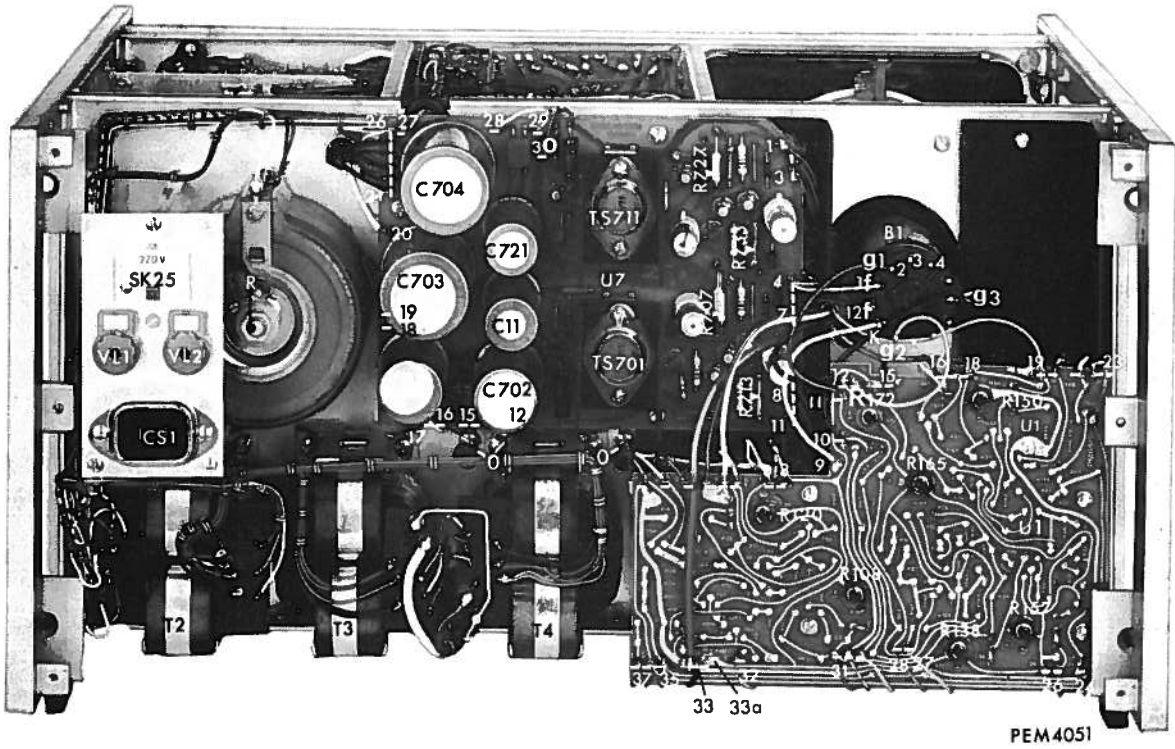

Fig. 73. Rear view (rear panel taken off)

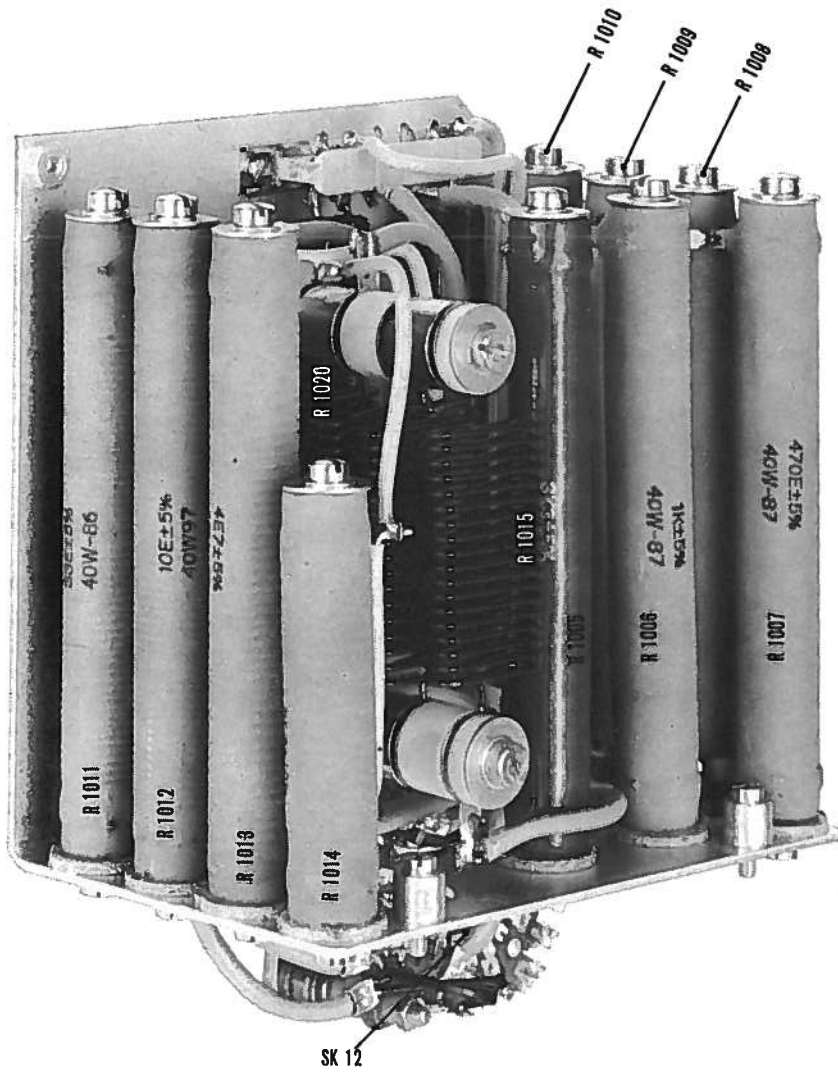

Fig. 74. Collector-load unit U10, taken off

4. Pilot lamp LA1

Remove the right-hand side panel (Fig. 71). Pull out the lamp holder in backward direction.

The lamp can now be easily replaced (screw fitting E10, voltage 6 V).

Pilot lamps LA2 and LA3.

Remove the bezel and the measuring lattice.

The lamps can then be replaced.
Bayonet sockets BA7s, voltage 6 V.

5. Switch knobs

The round switch knobs can be removed by carefully prizing off the cap with a knife and loosening the nut of the clamping cone. The knob can then be pulled off the spindle.

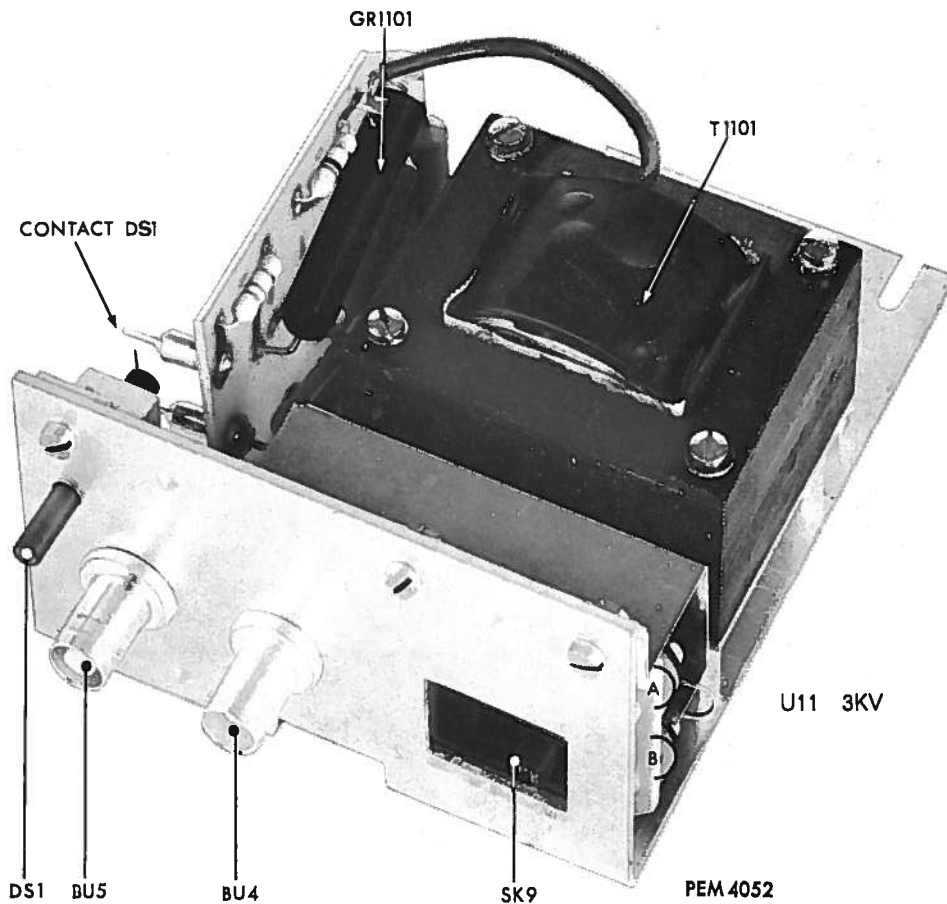

Fig. 75. H.T. unit U11 (3 kV), taken off

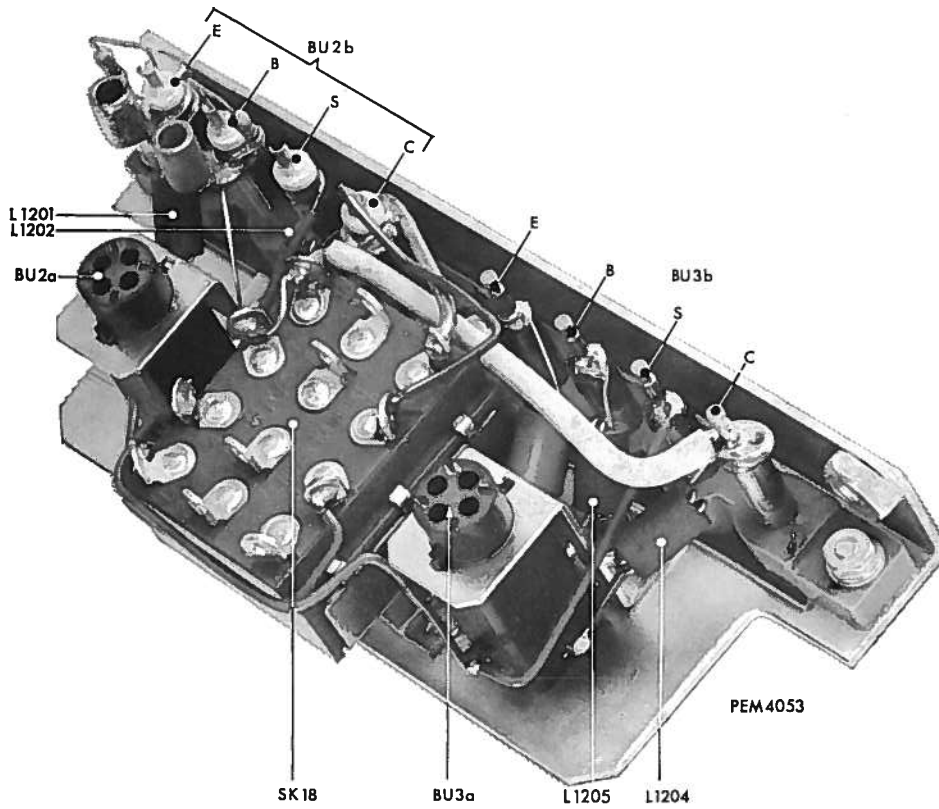

Fig. 76. Socket unit U12, taken off

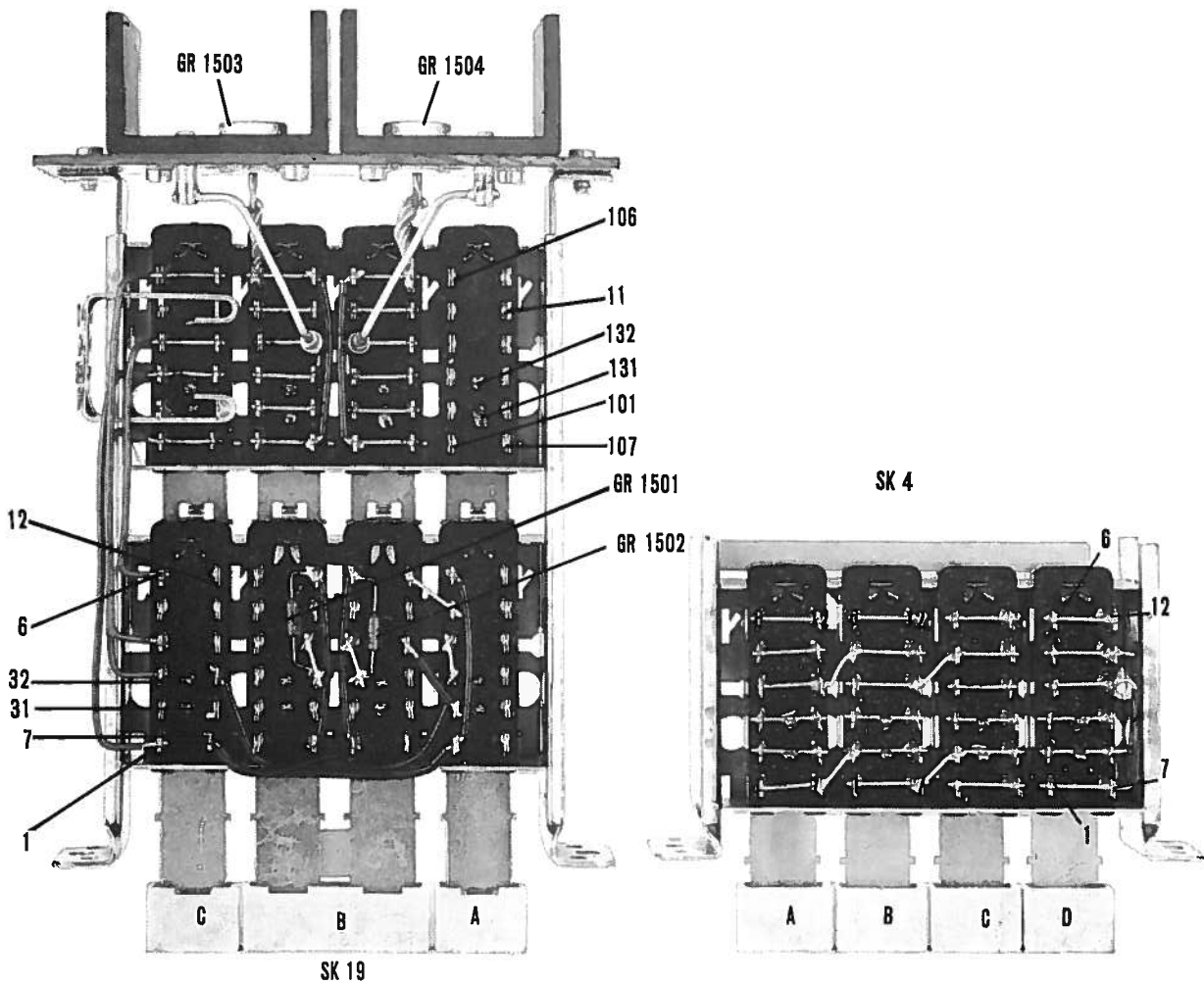

Fig. 77. Push-button unit U15 and SK4, taken off

X. Maintenance

Transistor curve tracer PM 6507 has no components which are actually subject to wear; therefore, the measuring instrument requires practically no maintenance.

However, to ensure trouble-free operation the instrument should not be exposed to excessive heat, moisture or dust. The perforations in the top plate should not be covered because otherwise the natural cooling will be impeded.

CAUTION:

Do not set the brightness to an unnecessarily high value. In case of continuous operation and a stationary image, the brightness should be kept as low as possible.

Avoid spots of high intensity to prevent burning in of the picture tube.

A few hints in the event of faults.

Due to the great number of controls and switching possibilities operating errors are likely to occur. It is advisable to first check the switch settings. Further instructions ar regards the relevant mode of operation are given in the directions for use.

In case of a fault it is always possible to consult the local service organisation.

CAUTION!

When carrying out measurements on an opened instrument be extremely careful to avoid short-circuits; in view of the EHT source only use insulated tools and clips!

XI. Survey of adjusting elements

The order given below is arbitrary. For the complete adjusting procedure please refer to chapter XII.

Fig.	Adjusting element	Function	Chapter XII, point
73	R713	Adjusting the Zener diodes	A1
73	R733		
73	R707	+30 V	A2a
73	R727	-30 V	A2a
62	R209	+300 V	Ba
63	R903	Phase adjustment	D1
63	R905		
110	R932	Duty-cycle adjustment	D2
110	R933		
63	R833	Step generator, gain	D3a
63	R802	Step adjustment	D3c, d
63	R806		
63	R811		
62	R3559	V_{CE} adjustment	E1d
63	R1303		
63	C1302		
63	R1304	Diode voltage adjustment	E2b
64	R6	Shield voltage	E3
62	R319	Balance adjustment	F1b
9	R303		
9	R403		
64	R305		
64	R405		
103	R419	Amplification	F1b
64	R311		
103	R411	Calibration voltage	F1c
100	R373		
73	R120	Output amplifier X-deflection	F2c
73	R108		
64	R311		
73	R138		
73	R157	Output amplifier Y-deflection	F2d
73	R150		
73	R172	Focusing	F3
73	R165	Brightness	F4
98	R195	Brightness limiter	F4
98	R196		

XII. Checking and adjusting

The tolerances mentioned are factory tolerances; they apply when the apparatus is readjusted completely. They may differ from the data given in IV.

A summary of the adjusting elements, their nomenclature and location has been given in XI. Before carrying out separate checks or adjustments, ensure that the instrument has no basic faults or deviations. The checking and adjusting instructions given in this chapter are therefore based on the assumption that the instrument basically is in good working order, as certain adjustments can only be carried out if the other adjustments are correct.

Moreover, the following general hints should be observed:

- Before the adjustment carry out a general functional check.
- Switch off all voltage and current sources in the instrument which are not required, or adjust them to the lowest possible value.
- During all adjustments the mains voltage should have the nominal value.
- When adjusting a switched-on instrument proceed with due care to avoid short-circuits with adjacent circuit elements. Use INSULATED screwdrivers and test clips only.
- For the connection of test clips or in case of soldering operations always switch off the instrument!

A. DIRECT VOLTAGES +30 V AND -30 V (U7)

Zener diodes GR714 and GR722 operate as reference elements for stabilising these voltages. These Zener diodes have been selected as regards optimum temperature coefficient.

1. Adjusting the Zener diodes.

When Zener diodes GR714 or GR722 operate at a certain current the temperature coefficient within a certain temperature interval will remain practically zero.

This current is determined and adjusted as follows: The choice resistor should be selected so that Zener voltage U_Z remains constant when the diode is war-

med up to approx. 60 °C and subsequently cooled down to approx. 20 °C and $\Delta U = \pm 1$ mV. Once the diode current has been adjusted, current I_Z should lie between 4.5 and 6 mA and the voltage between 5.4 and 5.6 V. If these values cannot be obtained the Zener diode is not suitable for this purpose.

Adjustment is effected outside the instrument according to the measuring diagram given in Fig. 78.

If no voltage of $30\text{ V} \pm 0.1\%$ is available, the other supply voltage can be employed provided that it has the correct value. Connection on U7: for +30 V: points 8, 9, 10; with respect to zero, for -30 V points 1, 2, 3 with respect to zero (points 4 - 7).

It is advised to warm up the diodes on the CATHODE CONNECTION by means of a soldering iron.

2. a. Output voltages +30 V and -30 V

These voltages are adjusted with R707 for +30 V and with R727 for -30 V.

Permissible deviation of the output voltage: $30\text{ V} \pm 30\text{ mV}$ ($\pm 0.1\%$).

The load of the output voltage should be approx. 100 - 150 mA, which corresponds to the quiescent current at the datum setting of the instrument (SK4 completely released, SK9 "OF", SK10 at 0, SK18 "OFF").

b. Stability of the output voltages

At a load of 50 - 150 mA the voltage variation should be < 5 mV.

Current limiting: for +30 V at 300 mA and for -30 V at 260 mA. The maximum current should not exceed 330 mA.

c. Hum voltage

At mains voltage variations of $\pm 15\%$ the hum voltage at the output should be $\leq 150\ \mu\text{V}_{\text{rms}}$ at a load of 180 mA.

3. Output voltage +31.5 V

The 1.5 V component added to the stabilised +30 V voltage is determined by GR712 and GR713. The output voltage should lie between 31.4 V and 31.6 V. In case of deviations replace the diodes.

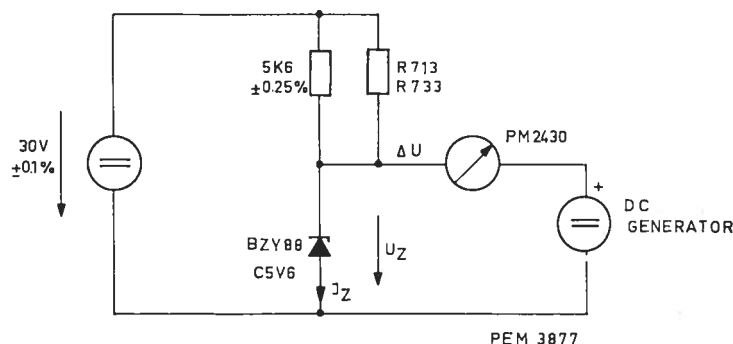

Fig. 78. Adjusting the zener diodes

B. EHT UNIT 4.5 kV (U2)

- a. Adjust the +300 V voltage with R209 average brightness.
- b. Check the 4.5 kV voltage by means of HT probe GM 6071 and d.c. voltmeter GM 6020, PM 2440 or PM 2430. Input resistance of the voltmeter 100 M Ω . Load resistance of the EHT circuit > 200 M Ω . Nominal value: 4500 V \pm 200 V.

C. 3 kV VOLTAGE FOR TESTING DIODES (U11)

Half-wave voltage adjustable with T1, max. value at nominal mains voltage approx. 3 kV.

Visual check on CRT:

- SK13 at 500 V,
- SK9 at μ A or nA,
- Slowly turn T1 fully clockwise. The voltage curve on the screen will then be 6 cm for 3 kV.

D. STEP GENERATOR (U9)

1. Phase adjustment of the trigger pulses

Phase adjustment of the trigger points can be effected by using a transistor as test object and observing the characteristics on the screen of the CRT

1st Phase

- Depress the 10 V button of SK4.
- Set T1 (V_{CE}) to mid position (e.g. 5 V).
- SK8 at 2.5 % duty cycle.
- SK13 at 1 V/cm.
- Set SK16 at a high sensitivity so that accurate adjustment is possible.
- Set SK1 at "100 from 0".
- SK7 at "REP FAM".
- SK3 at 8.
- Adjust the intersection point of the curves to zero or minimum by means of R903.

2nd Phase

Initial setting as above, however:

- SK1 at "100 to 0".
- With R905 adjust the trigger point to max. reversing point.

2. Duty-cycle adjustment 2.5 . . . 60 % + 100%

- Initial setting of instrument: use a transistor as test object and display a set of curves with SK7 at "REP. FAM".
- Turn SK8 fully clockwise (switch in the locked position). The mark on the knob should point towards the centre of position 100 %.
- Connect an oscilloscope to U9A/3.
- Set SK8 (R901) at position 2.5 %.
- The duty cycle phase should now be 250 μ s \pm 10 μ s.
- Adjustment is effected with R933 (for this, unit U9 must be removed).
- Set SK8 at 60 %.
- The duty cycle phase should now be 6 ms \pm 250 μ s.
- Adjustment is effected with R932.

3. Adjusting the amplifier (U8)

a. Adjustment of potentiometer "ZERO"

- Connect a resistor of 100 Ω \pm 0.2 % to sockets B and E.
- SK1 at "100 from 0".
- SK3 at 8.
- SK7 at "ONE CURVE".
- SK8 at 100 %.
- SK10 at 1 mA.
- R902 at the centre of its control range (mark under "ZERO").
- SK19: all buttons released.
- Connect a microvoltmeter or digital voltmeter to the external 100 Ω resistor.
- Adjust potentiometer R833 until the output current is 0 \pm 10 μ A (\leq \pm 1 mV3. If this is not possible replace TS814.
- This tolerance should also be maintained if button SK19A is depressed.

b. Adjustment of the negative deflection

Setting as under a, however:

- Set SK3 at 2 . . . 7.
- Set SK7 at "One Curve".
- Adjust potentiometer R811 so that the current per step is 1 mA for steps 2...7 (SK3).
- Adjust the 1st step (SK3 at 2) by means of R802. These adjustments should be carried out very accurately (\pm 1 % per step or 0.1 V \pm 1 mV across the 100 Ω resistor connected to B-E).

c. Adjustment of the positive deflection

Setting as under b, however:

- SK19A: depressed.
- Adjust potentiometer R806 so that the current per step is 1 mA for steps 1 - 8 (SK3); (tolerance \pm 1 % or 0.1 V \pm 1 mV across the 100 Ω resistor connected to B-E).

E. COLLECTOR VOLTAGE SUPPLY

1. Voltage ranges 10 Vp, 50 Vp, 100 Vp, 500 Vp

a. Range 0 - 10 Vp

- SK4A (10 V) depressed.
- SK13 at 2 V/cm.
- SK16 at 5 A/cm.
- SK18 at TS1.
- Turn T1 clockwise and check the X-deflection on the picture screen.
- Adjustment: 10 V = 5 cm screen distance.
- Connect an oscilloscope to BU2b C (high) and E (low) and check that both halfwaves are present.
- Connect a resistor or 1 Ω , 100W to BU2b, C and E.
- The trace should be deflected in the vertical direction over approx. 2 cm (2 cm = 10 A), according to Fig. 79 (the collector voltage source is not stabilised).
- Short-circuit C-E ($R_C = 0.5 \Omega$), $V_{CE} = 10$ Vp, $I_C = 20$ Ap. After approx. 20 - 25 sec thermal switch SK5 should cut out.
- Hum on the picture tube (Fig. 80):
- Short-circuit C-E ($R_C = 0.5 \Omega$), $V_{CE} = 10$ Vp, $I_C = 20$ Ap.
- SK13 at 1 V/cm.

b. Range 0 - 50 Vp

- SK4 B depressed.
- SK13 at 10 V/cm.
- SK16 at 1 A/cm.
- Connect a resistor of 10 Ω , 100 W to BU2b C-E.
- Set SK18 at TS1.
- Adjust V_{CE} to 50 V with T1 (5 cm).
- I_C should be approx. 3,6 A (\cong 3,6 cm).

c. Range 0 - 100 Vp

- SK4 C depressed.
- SK13 at 20 V/cm.
- SK16 at 500 mA/cm.
- Connect a resistor of 50 Ω , 100 W to BU2b, C-E.
- Set SK18 at TS1.
- Adjust the V_{CE} to 100 V with T1 (5 cm).
- I_C should be approx. 1.6 A (\cong 3.2 cm).

d. Range 0 - 500 Vp

- Depress SK4 D.
 - SK13 at 50 V/cm.
 - SK16 at 50 mA/cm.
 - Connect a resistor of 2 k Ω , 100 W to BU2, C.E.
 - Set SK18 at TS1.
 - Adjust the V_{CE} to 500 V with T1 (10 cm).
 - I_C should be approx. 0.2 A (\cong 4 cm).
- Adjustment at smaller currents:
- SK13 at 50 V/cm.
 - SK16 at 10 μ A/cm.
 - Adjust V_{CE} to 400 V with T1 (8 cm).
 - By means of R1303 and C1302 reduce the angle enclosed by the diverging lines and make the two traces coincide. Adjust R359 until the loop as closely as possible approximates a straight line. After the adjustment the trace should fit inside a rectangle of max. 7 mm height (7 μ A p-p) and a width of 8 cm (400 V).

2. High tension for testing diodes

a. μ A ranges

- None of the buttons of SK4 depressed.
- SK9 at " μ A".
- SK13 at 500 V/cm.
- SK14 at "INVERS".
- SK15 at "NORMAL".
- SK16 at 10 μ A/cm.
- SK17 at "x0.5".
- Depress DS1.
- Turn T1 clockwise until a horizontal line of 4 cm is obtained on the screen, corresponding to a voltage of 2,000 Vp.

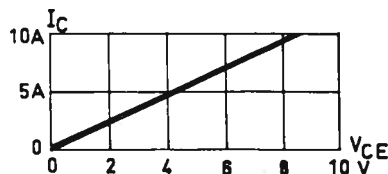

Fig. 79. Adjusting the collector-voltage source 0-10 V

b. nA ranges

- None of the buttons of SK4 depressed.
- SK6 at "SINGLE FAM".
- SK9 "nA".
- SK10 at 1 μ A/step.
- SK11 at "GROUNDED".
- SK16 at 10 nA/cm.
- SK17 at "x0.5".
- Turn R1 fully counter-clockwise.
- Depress DS1.
- Adjust the picture horizontally with R1304. The loop should be smaller than 6 mm (3 nA). Ensure that the instrument is earthed.

3. S control voltage

- Set SK20 at - (+).
- Turn R1 fully clockwise.
- The voltage on sockets S-E of BU2 (BU3) should be 10 V \pm 0.1 V (adjust by replacing R6).
- Repeat the check for the other polarity + (-).
- Check of , with SK20 at : S.E = 0 V.

F. MONITOR

1. Pre-amplifiers U3 A, and U4 A

Checking and adjusting of the amplifiers can be effected independent of the step signal and the collector circuit by switching the instrument to external operation and by applying a sine-wave voltage of approx. 200 Hz to the sockets on the left of the instrument. The adjustment is the same for the horizontal and vertical pre-amplifiers except for the expansion switch on unit U4. In the following description the indications in brackets refer to U4 A and the other indications to U3 A.

a. Checking the input stages as regards gate leakage current

With this check it should be observed that the leakage current of protection diodes GR301/GR302. The diodes should therefore be unsoldered.

If the leakage current of a FET is too high, both transistors in the relevant stage should be replaced because they have been selected in pairs (for the ordering code, see list of electrical parts).

- Connect a resistor of 1 M Ω \pm 5% to sockets B and H of BU6 (on the left-hand side of the instrument).
- Set switches SK13 and SK16 at "EXT".
- All buttons of SK4 should be released and T1 should be turned fully counter-clockwise.

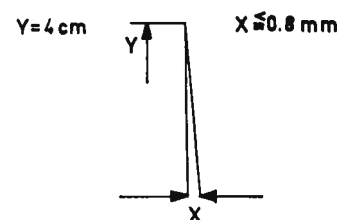

Fig. 80. Hum influence on the C.R.T.

- A small loop is now displayed on the screen. This trace should be adjusted to the centre of the screen at low brightness.

X-inputs:

- Short-circuit sockets D and H of BU6.
- The loop should not shift more than ± 3 mm in the horizontal direction (an angular shift of the loop does not affect this check).
- Short-circuit sockets M and H of BU6.
- Max. deviation in the horizontal direction ± 3 mm.

Y-inputs:

- Short-circuit sockets E and H.
- Max. deviation in vertical direction ± 3 mm.
- Short-circuit sockets B and H.
- Max. deviation in the vertical direction ± 3 mm.

b. Adjusting the pre-amplifiers

This is effected by means of an external sinewave voltage which should be applied to socket BU6 and checked by means of a millivoltmeter (e.g. PM 2520).

Balance adjustment

- Initial setting of the instrument according to Fig. 43.
- Set SK13 (SK 16) at "EXT".
- Set R303 (R403) "DC BAL" to the centre of the control range.
- Short-circuit sockets D and F of BU6 and connect a sinewave generator (e.g. PM 5121 to H/K (voltage 0 V)).
- With R319 (R419) adjust the output voltage to $< \pm 0.5$ Vd.c. (available on U1/32 for the X-amplifier, and on U1/25 for the Y-amplifier).
- Adjust the generator to $5 V_{\text{rms}}$ at 200 Hz.
- The alternating voltage on the output should be $< 10 \text{ mV}_{\text{rms}}$ (adjustable with R305-R405).

Gain adjustment

- With either input D or F connected to earth (E or B) connect the free input to the generator.
- Adjust the input voltage to $100 \text{ mV}_{\text{rms}}$ at 200 Hz.
- Connect an accurate millivoltmeter (e.g. PM 2451) to the output (U1/32 for X amplifier and U1/25 for the Y amplifier).
- Adjust the gain to $9.5 \pm 2\%$ (950 mV) and to $12 \pm 2\%$ (1.2 V) with potentiometer R311 (R411). Check the ranges $\times 5$ and $\times 0.5$ (SK17). These ranges are only present for the Y-amplifier. The gain is $2.4 \pm 5\%$ and $24 \pm 5\%$.
- After this check the adjustment with reversed input potential (arbitrarily earthed input).

c. Adjusting the calibration voltage

(Carry out this check when the instrument has attained operating temperature.) Measure the voltage between U3A/6b and U3A/9 with a digital voltmeter (e.g. PM 2433). This voltage should be 50 mV, \pm or -0.5% . If necessary select a different value for R373.

2. Adjusting the output amplifiers and yoke U1

Before these adjustments can be carried out the pre-amplifiers should be adjusted. The focusing and brightness control should also be correct. Moreover, the position of the deflection coils should be checked

before the adjustment, by checking the horizontal and vertical deflection axes. For this purpose the procedure below may be followed. If the axis is not correct, the deflection unit should be turned (for yoke fixation see under point IX. B).

a. Deflection coil (yoke)

Initial setting as under c and d respectively.

Adjust the picture axis accurately by means of the shift controls. By turning the yoke the line pattern can be made to coincide exactly with the graticule. This check should be effected both for the horizontal and the vertical deflection and in position "NORMAL" and "INVERS".

For minor corrections hexagon screw "G" (Fig. 62) should be loosened. The yoke can then be shifted slightly in both directions. For greater corrections screw "F" (Fig. 64) should be loosened; before this is done the holder should be aligned in the centre position and secured with screw "G" (for adjustment of the yoke see under IX. B).

b. Beam centring

Initial setting: as under c and d respectively.

- Shunt the yoke coils at the following points by means of short pieces of wire:
X: U1/4 - U1/5
Y: U1/18 - U1/19
- Before switching on the instrument turn down the brightness.
- By means of the adjusting plates at the rear of the yoke adjust the spot to the centre of the screen.
- Remove the short-circuit.
- Adjust the line pattern as described under point c.
- Use the correction magnets at top and bottom of the picture tube to correct the vertical lines so that the linearity error does not exceed ± 1 mm.
- Check the linearity at the top and bottom of the picture, the axis of the yoke should then be properly aligned.

c. X-deflection

Initial setting of the instrument for adjusting the X-amplifier:

- SK1 at 200
- SK2 at 20Ω
- SK3 at 8
- SK4 button 10 V depressed
- SK7 at REP FAM
- SK8 at 100%
- SK10 at 20 mV/step
- SK11 at DRIVEN
- SK12 at $2 \text{ k}\Omega$
- SK13 at 20 mV/cm (BASE VOLTAGE)
- SK14 at NORM
- SK15 at INVERS
- SK16 at $\mu\text{A}/\text{cm}$ (COLL. CURRENT)
- SK17 at $\times 1$
- SK18 at TS1
- SK19B depressed (NPN)
- R902 (ZERO) set to the centre of its control range
- T1: Adjusted to collector voltage of approx. 10 Vp, so that the lines cover the full screen width or screen height.
- BU2b: sockets C-E short-circuited.

At this setting the pattern of Fig. 81a should be displayed. Symmetry adjustment for the vertical and horizontal axes is effected with controls R302 and R401. Switching-over from situation a to b is effected with switch SK14 NORMAL/INVERS.

Adjustment:

- Set potentiometer R157 to the centre of its control range.
- Potentiometer R311 should not be at the end of its control range.
- R108: This potentiometer serves for adjusting the symmetry of the gain limitation.
- R120: This potentiometer serves for gain adjustment.

Gain and limitation should be adjusted (both left and right; SK14) so that the lines run exactly in parallel with the lines of the graticule. The setting of R108 (limitation) should be such that proper adjustment is possible by means of gain control R120. This procedure should be repeated at various settings of R108 until correct result is obtained.

d. Y-deflection

The initial setting is the same as with the adjustment of the X-amplifier described under c., however:

- SK13 at 1 V/cm (COLL. VOLTAGE)
- SK14 at NORMAL
- SK15 at NORMAL
- SK16 at 20 mV/cm (BASE VOLTAGE)
- SK18 at OFF.

At this setting the picture shown in Fig. 82a will be obtained.

Adjustment:

- R138: This potentiometer serves for adjusting the symmetry of the gain limitation.

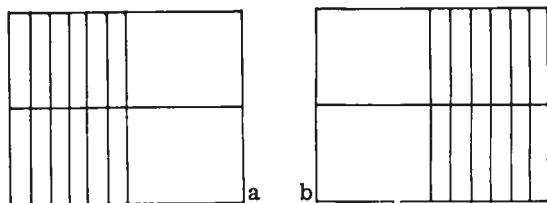

Fig. 81. Adjusting the X-deflection

R150: This potentiometer serves for gain adjustment. Adjustment of the lines displayed is effected in the same way as with the X-deflection. Reversal of the pattern is effected with SK15.

3. Focusing

For focusing adjustment potentiometer R172 should be used (Fig. 75). This potentiometer is accessible via a hole at the rear of the instrument. Adjustment should be effected at average brightness, until optimum sharpness is obtained.

4. Brightness control

The brightness is adjusted by means of potentiometer "INTENSITY" (R301) and brightness modulation with R165.

R165 should be adjusted so that the following requirements are met:

- It should be possible to completely suppress the beam with R301.
- When displaying a set of curves with reduced duty cycle (e.g. 40 %) the lower line (which is written 8 times when SK3 is at 8) should not be visible or only poorly.
- The control range of R301 should be sufficient to display the lower line completely or partially.

Protection circuit

By means of resistors R195 and R196 the limiting circuit can be adjusted. Normally, only R196 is included; by interrupting the printed circuit track at the edge of U1A (see Fig. 18) R195 can be included and R196 can be short circuited by soldering the print track under R196 together (minimum value 33 k Ω).

High resistance = small brightness variations.

Low resistance = great brightness variations.

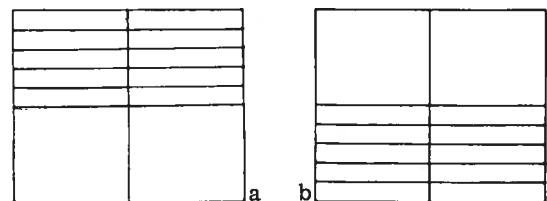

Fig. 82. Adjusting the Y-deflection

XIII. The shipment of the instrument

REMARK

In case of breakdowns one can always apply to the world-wide PHILIPS Service Organisation. Whenever it is desired to send the instrument to a PHILIPS Service Centre for repair, the following points should be observed:

- tie on a label, bearing full name and address of the sender;
- indicate as complete as possible the symptom(s) of the fault(s);
- carefully pack the instrument in the original packing, or, if no longer available, in a wooden crate;
- send the instrument to the address provided by your local PHILIPS representative.

XIV. List of parts

A. MECHANICAL PARTS

Item	Fig.	Qty	Ordering number	Description
1	83	4	4822 505 10314	Knurled nut
2	83	1	4822 450 10027	Measuring lattice
2a	83	1	4822 480 30073	Contrast filter
3	83	3	4822 276 10224	Push-button switch (SK6, SK10A, SK13A)
4	83	1	4822 455 90311	Instruction plate
5	83	10	4822 277 20009	Sliding switch 3-pos. (SK1, 7, 9a, 9b, 11, 14, 15, 17, 20, 21)
6		1	4822 413 30329	Switch knob, 14.5 mm dia.
7	83	1	4822 276 40098	Set of push-buttons SK4
8	83	1	4822 280 40097	Thermo-switch
9	83	1	4822 413 40211	Knob 23 mm dia.
10	83	1	4822 411 60086	Knob for SK9
11	83	1	4822 267 10033	B.N.C. socket BU4
12	83	1	4822 267 10008	B.N.C. socket BU5
13	83	1	4822 277 10021	Mains switch
14	83	1	4822 413 30083	Knob 14.5 mm dia., shaft 4 mm dia.
15	83	1	4822 276 40099	Set of push-buttons SK19
16	83	2	4822 267 40093	Socket block (BU3b)
17	83	2	4822 255 40002	Transistor socket (h.f.) (BU2a, BU3a)
18	83	2	4822 413 30082	Knob 14.5 mm dia., shaft 6 mm dia.
19	83	4	4822 413 70038	Cover for 14.5 mm dia knob
20	83	1	4822 277 10149	Switch SK18
21	83	5	4822 413 40112	Switch knob 23 mm dia.
22	83	6	4822 413 70037	Cover for 23 mm dia. knob
23	83	4	4822 413 30156	Knob 10 mm dia.
24	83	1	4822 290 40012	Earth terminal
25	84	2	4822 277 20014	Sliding switch (SK22, SK25)
26	84	2	4822 256 40012	Fuse holder
27	84	1	4822 265 20005	Mains connection
28		1	4822 267 40142	Socket block (BU2b)

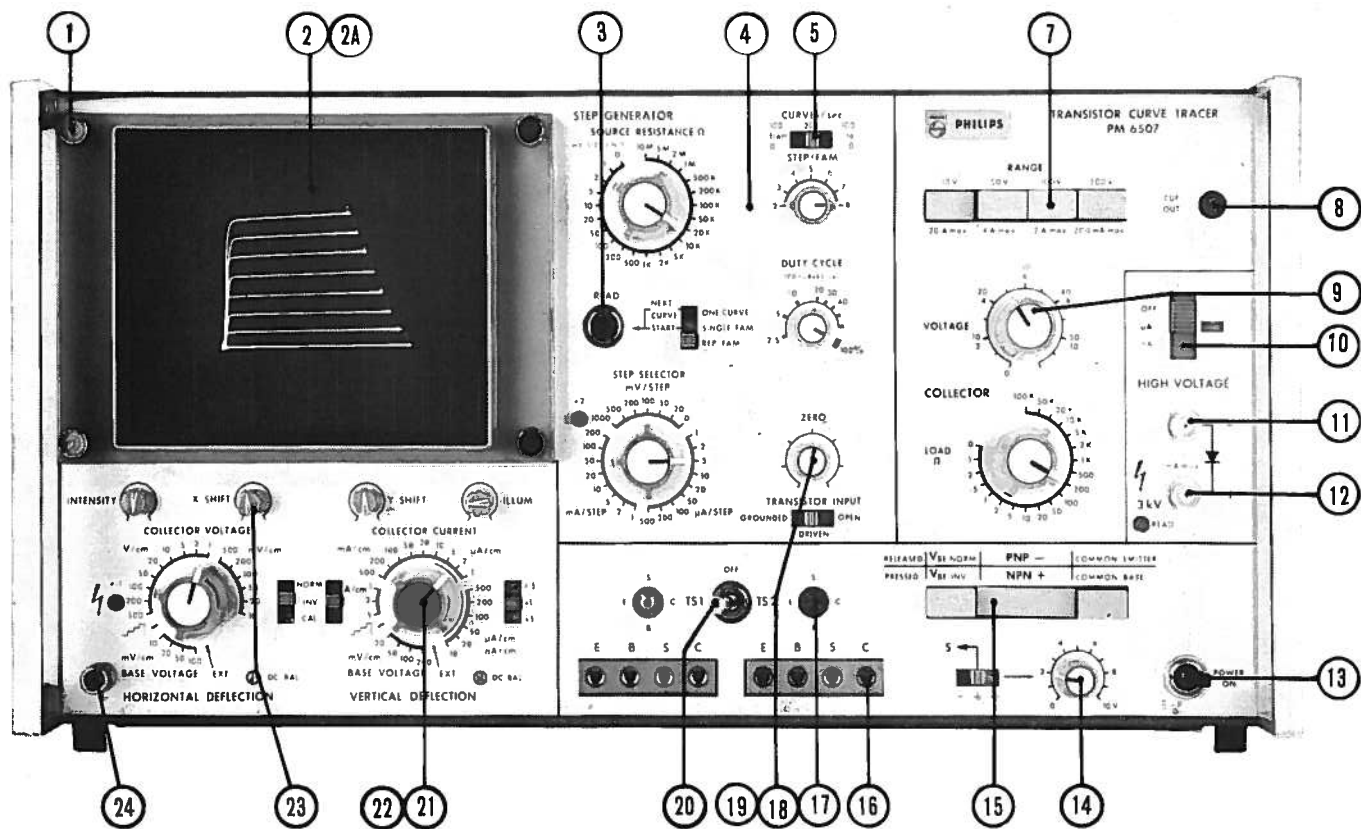

Fig. 83. Front view with item numbers

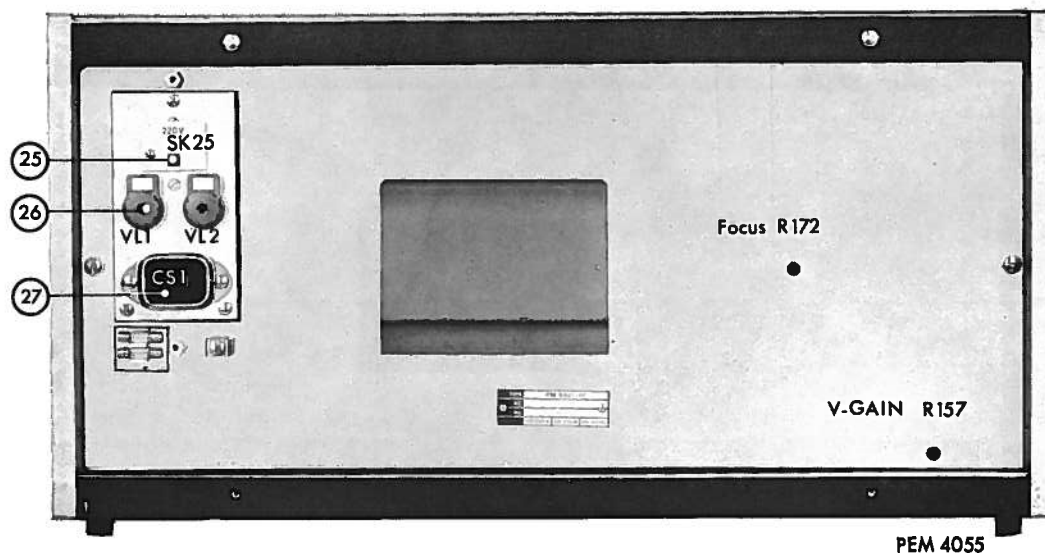

Fig. 84. Rear view with item numbers

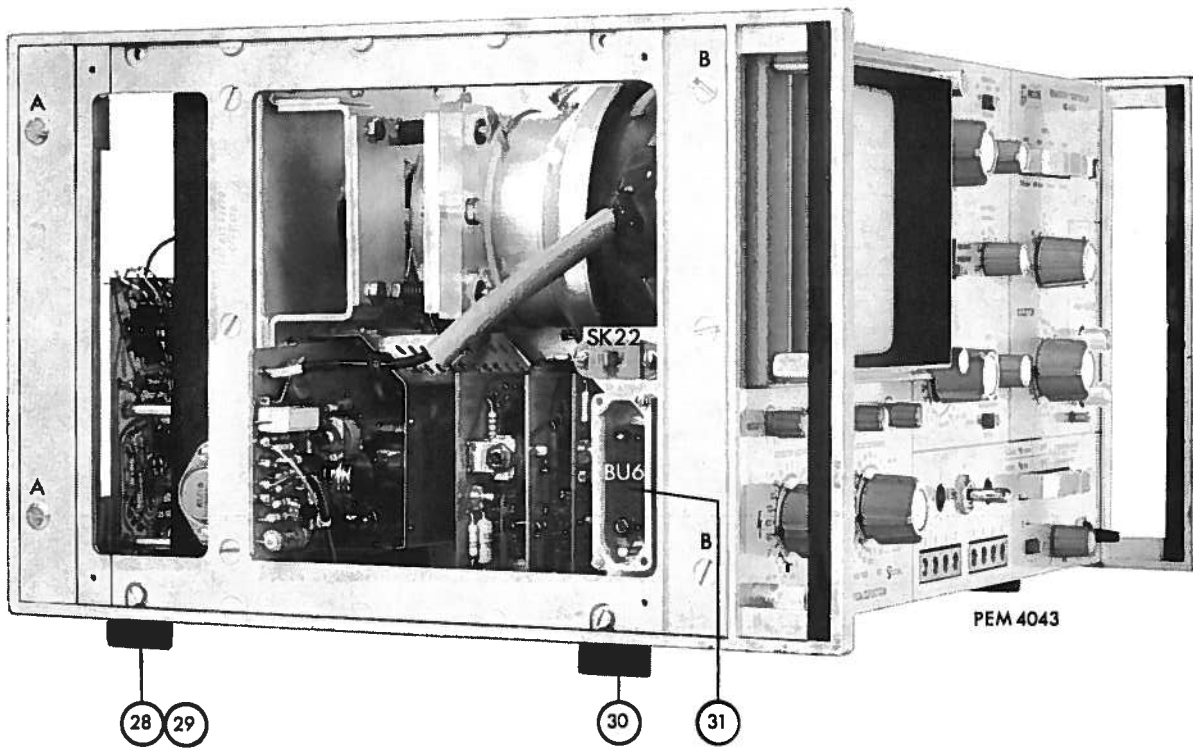

Fig. 85. Side view (left) with item numbers

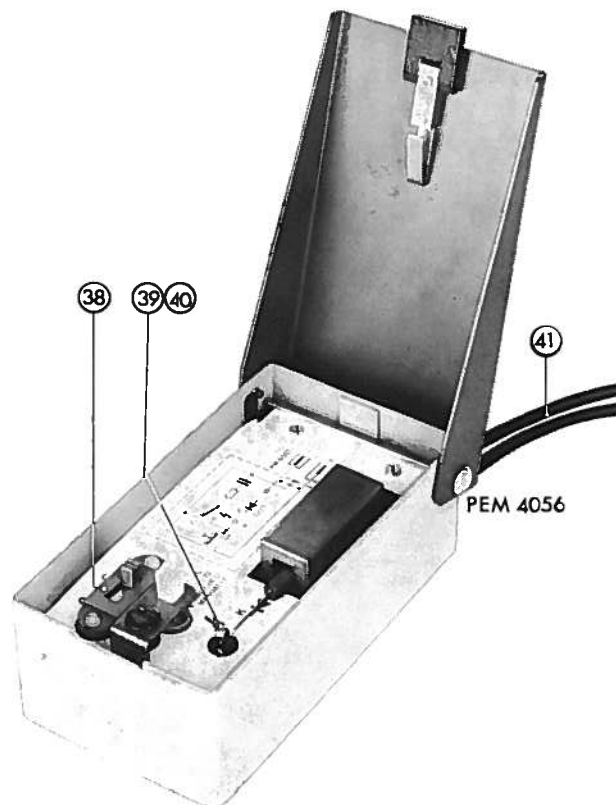

Fig. 86. PM 6546 with item numbers

Item	Fig.	Qty	Ordering number	Description
28	85	4	4822 462 40157	Rubber block for feet
29	85	2	4822 462 50101	Foot, rear
30	85	2	4822 462 40092	Foot, front
31	85	1	4822 267 50079	Connector BU6
31a		1	4822 265 50031	Plug for BU6
31b		1	4822 268 40034	Cover for item 31a
32		1	4822 273 30136	Rotary switch SK2
33		1	4822 273 30135	Rotary switch SK3
34		1	4822 273 60058	Rotary switch SK10
35		1	4822 273 40178	Rotary switch SK12
36		1	4822 273 50078	Rotary switch SK13
37		1	4822 273 80098	Rotary switch SK16
			PM6546	
38	86	1	4822 277 20009	Sliding switch
39	86	2	4822 290 30094	Clamping spring
40	86	2	4822 462 70503	Protective cap
41	86	2m	4822 320 10008	Cable
42		1	4822 264 10006	BNC, long
43		1	4822 265 10003	BNC, short
44		1	4822 216 90175	Printed wiring board with components
C1 . . . 4		4	4822 121 40164	Capacitor 0.22 μ F, 1000 V
R1,2		2	4822 111 50284	Resistor 100 M Ω , 5 %, 1 W
R3		1	4822 110 40161	Resistor 100 k Ω , 5 %, 0.5 W
			PM 6544, 47, 48	
		4	4822 268 10027	Plug pin
			PM 6547	
		1	4822 255 40002	Transistor holder
		3	4822 152 20377	Coil
			PM 6549A	
		1	4822 255 40001	Transistor holder

B. ELECTRICAL — ELEKTRISCH — ELEKTRISCH — ELECTRIQUE — ELECTRICOS



















This parts list does not contain multi-purpose and standard parts. These components are indicated in the circuit diagram by means of identification marks. The specification can be derived from the survey below.

Diese Ersatzteilliste enthält keine Universal- und Standard-Teile. Diese sind im jeweiligen Prinzipschaltbild mit Kennzeichnungen versehen. Die Spezifikation kann aus nachstehender Übersicht abgeleitet werden.

In deze stuklijst zijn geen universele en standaardonderdelen opgenomen. Deze componenten zijn in het prinsipschema met een merkteken aangegeven. De specificatie van deze merktekens is hieronder vermeld.

La présente liste ne contient pas des pièces universelles et standard. Celles-ci ont été repérées dans le schéma de principe. Leurs spécifications sont indiquées ci-dessous.

Esta lista de componentes no comprende componentes universales ni standard. Estos componentes están provistos en el esquema de principio de una marca. El significado de estas marcas se indica a continuación.

	Carbon resistor E24 series Kohleschichtwiderstand, Reihe E24 Koolweerstand E24 reeks Résistance au carbone, série E24 Resistencia de carbón, serie E24	} 0,125 W	5%		Carbon resistor E12 series Kohleschichtwiderstand, Reihe E12 Koolweerstand E12 reeks Résistance au carbone, série E12 Resistencia de carbón, serie E12	} 1	W ≤ 2,2 MΩ, 5% > 2,2 MΩ, 10%		
	Carbon resistor E12 series Kohleschichtwiderstand, Reihe E12 Koolweerstand E12 reeks Résistance au carbone, série E12 Resistencia de carbón, serie E12			} 0,25 W	≤ 1 MΩ, 5% > 1 MΩ, 10%				Carbon resistor E12 series Kohleschichtwiderstand, Reihe E12 Koolweerstand E12 reeks Résistance au carbone, série E12 Resistencia de carbón, serie E12
	Carbon resistor E24 series Kohleschichtwiderstand, Reihe E24 Koolweerstand E24 reeks Résistance au carbone, série E24 Resistencia de carbón, serie E24	} 0,5 W	≤ 5 MΩ, 1% > 5 MΩ, 2% > 10 MΩ, 5%				Wire-wound resistor Drahtwiderstand Draadgewonden weerstand Résistance bobinée Resistencia bobinada	} 0,4 – 1,8 W	0,5%
	Carbon resistor E12 series Kohleschichtwiderstand, Reihe E12 Koolweerstand E12 reeks Résistance au carbone, série E12 Resistencia de carbón, serie E12			} 0,5 W	≤ 1,5 MΩ, 5% > 1,5 MΩ, 10%		Wire-wound resistor Drahtwiderstand Draadgewonden weerstand Résistance bobinée Resistencia bobinada		
	Wire-wound resistor Drahtwiderstand Draadgewonden weerstand Résistance bobinée Resistencia bobinada	} 10 W	5%				Tubular ceramic capacitor Rohrkondensator Keramische kondensator, buistype Condensateur céramique tubulaire Condensador cerámico tubular	} 500 V	
	Tubular ceramic capacitor Rohrkondensator Keramische kondensator, buistype Condensateur céramique tubulaire Condensador cerámico tubular			} 700 V		Flat-foil polyester capacitor Miniatur-Polyesterkondensator (flach) Platte miniatur polyesterkondensator Condensateur au polyester, type plat Condensador polyester, tipo de placas planas	} 250 V		
	Ceramic capacitor, "pin-up" Keramikkondensator "Pin-up" (Perltyp) Keramische kondensator "Pin-up" type Condensateur céramique, type perle Condensador cerámico, versión "colgable"	} 500 V			Paper capacitor Papierkondensator Papierkondensator Condensateur au papier Condensador de papel	} 1000 V			
	"Microplate" ceramic capacitor Miniatur-Scheibenkondensator "Microplate" keramische kondensator Condensateur céramique "microplaca" Condensador cerámico "microplaca"		} 30 V		Wire-wound trimmer Drahttrimmer Draadgewonden trimmer Trimmer à fil Trimmer bobinado		}		
	Mica capacitor Glimmerkondensator Micakondensator Condensateur au mica Condensador de mica	} 500 V			Tubular ceramic trimmer Rohrtrimmer Buisvormige keramische trimmer Trimmer céramique tubulaire Trimmer cerámico tubular	}			



For multi-purpose and standard parts, please see PHILIPS' Service Catalogue.

Für die Universal- und Standard-Teile siehe den PHILIPS Service-Katalog.

Voor universele en standaardonderdelen raadplege men de PHILIPS Service Catalogus.

Pour les pièces universelles et standard veuillez consulter le Catalogue Service PHILIPS.

Para piezas universales y standard consulte el Catálogo de Servicio PHILIPS.

CONDENSATOREN

Item	Ordering number	Value	Tolerance	Voltage	Description
C1	4822 121 10296	2 μ F		630 V	Metal-paper
C101	4822 121 40047	10 nF	10 %	250 V	Tubular
C131	4822 121 40047	10 nF	10 %	250 V	Tubular
C161	4822 124 20091	8 μ F		40 V	Electrolytic
C162	4822 121 50235	3.3 nF	10 %	125 V	Polyester
C163	4822 121 50149	2.2 nF	10 %	125 V	Polyester
C192	4822 124 20047	25 μ F		6,4 V	Electrolytic
C193	4822 124 20056	6.4 μ F		25 V	Electrolytic
C194	4822 124 20085	1 μ F		40 V	Electrolytic
C201	4822 124 20097	32 μ F		64 V	Electrolytic
C202	4822 124 20056	6.4 μ F		25 V	Electrolytic
C203	4822 121 40013	1 μ F	10 %	250 V	Polyester
C205	4822 122 50032	680 pF	20 %	3000 V	Ceramic
C207	4822 121 40167	82 nF	10 %	400 V	Polyester
C208	4822 122 50031	1.5 nF	20 %	6000 V	Ceramic
C302	4822 121 40049	15 nF	10 %	250 V	Disc capacitor
C402	4822 121 40049	15 nF	10 %	250 V	Disc capacitor
C701	4822 124 40004	1250 μ F		25 V	Electrolytic
C702	4822 124 40004	1250 μ F		25 V	Electrolytic
C703	4822 124 40083	2500 μ F		25 V	Electrolytic
C704	4822 124 40083	2500 μ F		25 V	Electrolytic
C711	4822 124 30032	320 μ F		64 V	Electrolytic
C713	4822 124 20093	8 μ F		64 V	Electrolytic
C714	4822 124 20047	25 μ F		40 V	Electrolytic
C721	4822 124 30032	320 μ F		64 V	Electrolytic
C723	4822 124 20093	8 μ F		64 V	Electrolytic
C724	4822 124 20047	25 μ F		40 V	Electrolytic
C725	4822 124 20098	5 μ F		64 V	Electrolytic
C726	4822 124 20098	5 μ F		64 V	Electrolytic
C901	4822 121 40027	1.5 μ F	10 %	100 V	Polyester
C905	4822 124 20052	12.5 μ F		25 V	Electrolytic
C906	4822 124 20052	12.5 μ F		25 V	Electrolytic
C907	4822 124 20054	25 μ F		25 V	Electrolytic
C908	4822 124 20052	12.5 μ F		25 V	Electrolytic
C909	4822 124 20052	12.5 μ F		25 V	Electrolytic
C912	4822 124 20022	50 μ F		40 V	Electrolytic
C914	4822 121 50275	150 nF	1 %	63 V	Polyester
C915	4822 121 50282	91 nF	1 %	63 V	Polyester
C918	4822 124 20086	16 μ F		40 V	Electrolytic
C935	4822 121 40047	10 nF	10 %	250 V	Disc capacitor
C1302	4822 125 60015	18 pF		800/1300 V	Trimmer

RESISTORS

Item	Ordering number	Value	Tolerance	Power	Description
R1	4822 101 20084	10 k Ω	20 %	0.1 W	Carbon potentiometer
R108	4822 101 20084	10 k Ω	20 %	0.1 W	Carbon potentiometer
R111	4822 111 20034	100 k Ω	1 %	0.125 W	Carbon
R114	4822 111 20034	100 k Ω	1 %	0.125 W	Carbon
R120	4822 101 20073	1 k Ω	20 %	0.1 W	Carbon potentiometer
R123	4822 113 60027	1.2 Ω	10 %	2 W	Wire wound
R124	4822 110 60109	1.2 Ω	10 %	0.125 W	Carbon
R138	4822 101 20084	10 k Ω	20 %	0.1 W	Carbon potentiometer
R141	4822 111 20034	100 k Ω	1 %	0.125 W	Carbon
R144	4822 111 20034	100 k Ω	1 %	0.125 W	Carbon
R150	4822 113 60027	1 k Ω	20 %	0.1 W	Carbon potentiometer
R153	4822 113 60075	1.2 Ω	10 %	2 W	Wire wound (2 in par.)
R154	4822 110 60107	1 k Ω	5 %	0.125 W	Carbon
R157	4822 101 20076	4.7 k Ω	20 %	0.1 W	Carbon potentiometer
R165	4822 101 20071	100 k Ω	20 %	0.1 W	Carbon potentiometer
R172	4822 101 20081	470 k Ω	20 %	0.1 W	Carbon potentiometer
R209	4822 103 20081	470 k Ω	20 %	0.1 W	Carbon potentiometer
R301	4822 103 20191	15 k Ω	10 %	3 W	Wire potentiometer
R302a + b	4822 102 30085	47 + 470 k Ω		0.25 W	Dual carbon potentiometer
R303	4822 101 20076	4.7 k Ω	20 %	0.1 W	Carbon potentiometer
R304	4822 116 50245	14.5 k Ω	0.5 %	0.25 W	Metal film
R305	4822 101 20073	1 k Ω	20 %	0.1 W	Carbon
R310	4822 116 50246	10.7 k Ω	0.5 %	0.25 W	Metal film
R311	4822 101 20073	1 k Ω	20 %	0.1 W	Carbon potentiometer
R317	4822 116 50246	10.7 k Ω	0.5 %	0.25 W	Metal film
R318	4822 116 50247	3.6 k Ω	1 %	0.25 W	Metal film
R319	4822 101 20076	4.7 k Ω	20 %	0.1 W	Carbon potentiometer
R322	4822 116 50121	15 k Ω	0.5 %	0.25 W	Metal film (2 in par.)
R330	4822 112 10114	90 Ω	0.5 %	0.4 W	Wire wound (2 in par.)
R332	4822 112 10088	40 Ω	0.5 %	0.4 W	Wire wound (2 in par.)
	4822 113 10017	40 Ω			
R333	4822 112 10083	60 Ω	0.5 %	0.4 W	Wire wound (2 in par.)
R339	4822 116 50013	6 k Ω	0.5 %	0.25 W	Metal film
R340	4822 116 50189	10 k Ω	0.5 %	0.25 W	Metal film
R341	4822 116 50165	20 k Ω	0.5 %	0.25 W	Metal film
R342	4822 116 50145	60 k Ω	0.5 %	0.25 W	Metal film
R343	4822 116 50069	100 k Ω	0.5 %	0.25 W	Metal film
R346	4822 113 10017	40 Ω	0.5 %	0.4 W	Wire wound (in par.)
	4822 112 10088	40 Ω			
R347, 329	4822 112 10083	60 Ω	0.5 %	0.4 W	Wire wound (in par.)
R353	4822 116 50013	6 k Ω	0.5 %	0.25 W	Metal film
R354	4822 116 50189	10 k Ω	0.5 %	0.25 W	Metal film
R355	4822 116 50165	20 k Ω	0.5 %	0.25 W	Metal film
R356	4822 116 50145	60 Ω	0.5 %	0.25 W	Metal film
R357	4822 116 50069	100 k Ω	0.5 %	0.25 W	Metal film
R359	4822 101 20076	4.7 k Ω	20 %	0.1 W	Carbon potentiometer
R365	4822 113 60026	0.82 Ω	10 %	2 W	Wire wound
R371	4822 116 50246	10.7 k Ω	1 %	0.25 W	Metal film
R372	4822 112 10087	91 Ω	1 %	0.4 W	Wire wound (2 in par.)
R381	4822 116 50248	4.43 k Ω	1 %	0.25 W	Metal film

Item	Ordering number	Value	Tolerance	Power	Description
R382	4822 116 50249	2.8 k Ω	1 %	0.25 W	Metal film
R383	4822 116 50037	8.45 k Ω	1 %	0.25 W	Metal film
R384	4822 116 50037	8.45 k Ω	1 %	0.25 W	Metal film
R385	4822 113 40035	333 Ω	0.5 %	0.4 W	Wire wound
R401a + b	4822 102 30085	47 + 470 k Ω		0.25 W	Dual carbon potentiometer
R402	4822 103 20186	47 k Ω		3 W	Wire potentiometer
R403	4822 101 20076	4.7 k Ω	20 %	0.1 W	Carbon potentiometer
R404	4822 116 50245	14.5 k Ω	0.5 %	0.25 W	Metal film
R405	4822 101 20073	1 k Ω	20 %	0.1 W	Carbon potentiometer
R407	4822 116 50254	1.74 k Ω	0.5 %	0.25 W	Metal film
R410	4822 116 50246	10.7 k Ω	0.5 %	0.25 W	Metal film
R417	4822 116 50246	10.7 k Ω	0.5 %	0.25 W	Metal film
R418	4822 116 50024	1.35 k Ω	0.5 %	0.25 W	Metal film
R419	4822 101 20076	4.7 k Ω	20 %	0.1 W	Carbon potentiometer
R422	4822 116 50121	15 k Ω	0.5 %	0.25 W	Metal film (2 in par.)
R428	4822 116 50037	8.45 k Ω	1 %	0.25 W	Metal film
R429	4822 116 50037	8.45 k Ω	1 %	0.25 W	Metal film
R430	4822 116 50249	2.8 k Ω	1 %	0.25 W	Metal film
R431	4822 116 50029	1.27 k Ω	1 %	0.25 W	Metal film (2 in par.)
R432	4822 116 50132	1.15 k Ω	1 %	0.25 W	Metal film (in par.)
	4822 116 50099	1.15 k Ω			
R433	4822 116 50252	584 k Ω	1 %	0.25 W	Metal film
R434	4822 116 50253	323 k Ω	1 %	0.25 W	Metal film
R435	4822 116 50254	103 k Ω	1 %	0.25 W	Metal film
R436	4822 116 50255	51 k Ω	1 %	0.25 W	Metal film
R437	4822 116 50145	30 k Ω	1 %	0.25 W	Metal film (2 in par.)
R438	4822 116 50118	10 k Ω	1 %	0.25 W	Metal film
R439	4822 116 50118	5 k Ω	1 %	0.25 W	Metal film (2 in par.)
R445	4822 112 10081	50 Ω	0.5 %	0.4 W	Wire wound (2 in par.)
R501	4822 113 60056	1 Ω	10 %	2 W	Wire wound
R502	4822 113 60056	1 Ω	10 %	2 W	Wire wound
R503	4822 112 20047	5.6 Ω	10 %	5.5 W	Wire wound
R504	4822 112 20105	8.2 Ω	10 %	5.5 W	Wire wound
R505	4822 112 20045	4.7 Ω	10 %	5.5 W	Wire wound
R506	4822 112 20054	10 Ω	10 %	5.5 W	Wire wound
R507	4822 112 20067	33 Ω	10 %	5.5 W	Wire wound
R508	4822 112 20072	47 Ω	10 %	5.5 W	Wire wound
R509	4822 112 20081	100 Ω	10 %	5.5 W	Wire wound
R510	4822 112 20094	330 Ω	5 %	5.5 W	Wire wound
R511	4822 110 40098	470 Ω	5 %	0.5 W	Carbon
R512	4822 110 40107	1 k Ω	5 %	0.5 W	Carbon
R513	4822 110 40121	3.3 k Ω	5 %	0.5 W	Carbon
R514	4822 110 40125	4.7 k Ω	5 %	0.5 W	Carbon
R515	4822 110 40134	10 k Ω	5 %	0.25 W	Carbon
R516	4822 110 50147	33 k Ω	5 %	0.25 W	Carbon
R517	4822 110 50152	47 k Ω	5 %	0.25 W	Carbon
R518	4822 110 50161	100 k Ω	5 %	0.25 W	Carbon
R519	4822 110 50174	330 k Ω	5 %	0.25 W	Carbon
R520	4822 110 50178	470 k Ω	5 %	0.25 W	Carbon
R521	4822 110 50187	1 M Ω	5 %	0.25 W	Carbon
R522	4822 110 50201	3.3 M Ω	10 %	0.25 W	Carbon

Item	Ordering number	Value	Tolerance	Power	Description
R523	4822 110 50205	4.7 M Ω	10 %	0.25 W	Carbon
R601	4822 115 80075				Shunt
R602	4822 115 80077				Shunt
R603	4822 115 80078				Shunt
R604	4822 115 80078				Shunt
R605	4822 115 80079				Shunt
R606	4822 115 80079				Shunt
R607	4822 116 50144	50 k Ω	0.5 %	0.25 W	Metal film
R608	4822 116 50145	30 k Ω	0.5 %	0.25 W	Metal film (2 in par.)
R609	4822 116 50118	10 k Ω	0.5 %	0.25 W	Metal film
R610	4822 116 50118	5 k Ω	0.5 %	0.25 W	Metal film (2 in par.)
R611	4822 112 10119	3 k Ω	0.5 %	0.4 W	Wire wound
R619	4822 112 10054	5 Ω	0.5 %	0.4 W	Wire wound (2 in par.)
R622	4822 115 80081				Shunt
R623	4822 115 80081				Shunt
R631	4822 110 30134	10 k Ω	1 %	0.125 W	Carbon
R708	4822 113 10001	1.54 k Ω	1 %	0.4 W	Wire wound
R728	4822 113 10001	1.54 k Ω	1 %	0.4 W	Wire wound
R802	4822 101 20071	100 k Ω	20 %	0.1 W	Carbon potentiometer
R806	4822 101 20076	4.7 k Ω	20 %	0.1 W	Carbon potentiometer
R811	4822 101 20073	1 k Ω	20 %	0.1 W	Carbon potentiometer
R833	4822 101 20084	10 k Ω	20 %	0.1 W	Carbon potentiometer
R841	4822 116 30062	15 k Ω	20 %	0.6 W	N.T.C.
R901	4822 101 50059	47 k Ω	20 %	0.125 W	Carbon potentiometer
R902	4822 102 30136	2x22 k Ω			Dual potentiometer
R903	4822 103 20081	22 k Ω	20 %	0.1 W	Carbon potentiometer
R905	4822 101 20084	10 k Ω	20 %	0.1 W	Carbon potentiometer
R962	4822 116 50366	151.5 k Ω	0.25 %	0.25 W	Metal film
R966	4822 116 50367	85.9 k Ω	0.25 %	0.25 W	Metal film
R970	4822 116 50368	59.9 k Ω	0.25 %	0.25 W	Metal film
R974	4822 116 50369	46 k Ω	0.25 %	0.25 W	Metal film
R978	4822 116 50371	37.25 k Ω	0.25 %	0.25 W	Metal film
R982	4822 116 50372	31.24 k Ω	0.25 %	0.25 W	Metal film
R986	4822 116 50373	26.83 k Ω	0.25 %	0.25 W	Metal film
R1001	4822 113 80027	47 k Ω	5 %	16 W	Wire wound
R1002	4822 113 80015	33 k Ω	5 %	16 W	Wire wound
R1003	4822 115 40109	10 k Ω	5 %	16 W	Wire wound
R1004	4822 115 40095	4.7 k Ω	5 %	16 W	Wire wound
R1005	4822 115 50102	3.3 k Ω	5 %	40 W	Wire wound
R1006	4822 115 50073	1 k Ω	5 %	40 W	Wire wound
R1007	4822 115 50069	470 Ω	5 %	40 W	Wire wound
R1008	4822 115 50067	330 Ω	5 %	40 W	Wire wound
R1009	4822 115 50062	100 Ω	5 %	40 W	Wire wound (adjusted to 100 Ω)
R1010	4822 115 50061	47 Ω	5 %	40 W	Wire wound (adjusted to 47 Ω)
R1011	4822 115 50059	33 Ω	5 %	40 W	Wire wound (adjusted to 33 Ω)
R1012	4822 115 50055	10 Ω	5 %	40 W	Wire wound
R1013	4822 115 50119	4.7 Ω	5 %	40 W	Wire wound
R1014	4822 115 50002	3.3 Ω	10 %	25 W	Wire wound
R1303	4822 101 20084	10 k Ω	20 %	0.1 W	Carbon potentiometer
R1304	4822 101 20084	10 k Ω	20 %	0.1 W	Carbon potentiometer

MISCELLANEOUS

Item	Ordering number	Description
T1	2422 530 01407	Variable transformer (supplied by ELCOMA)
T2	4822 146 40163	Mains transformer
T3	4822 148 20075	Collector transformer
T4	4822 148 20075	Collector transformer
T201	4822 158 40034	H.T. transformer
T1101	4822 148 20076	H.T. transformer
L1	4822 150 10072	Deflection coil
L601	4822 158 10132	Wide-band choke
L1201	4822 526 10036	Wide-band choke
L1202	4822 526 10036	Wide-band choke
L1203	4822 526 10036	Wide-band choke
L1204	4822 526 10036	Wide-band choke
LA1	4822 134 40054	6 V, 0.1 A Bulb
LA2	4822 134 40005	6.3 V, 0.63 W Bulb
LA3	4822 134 40005	6.3 V, 0.63 W Bulb
B1	AW 17/69	C.R.T.
	Complete printed-wiring boards	
U1	4822 216 90074	Final amplifier
U1A	4822 216 90234	Intensity control
U2	4822 216 90075	H.T. circuit
U3A	4822 216 90076	Pre-amplifier
U3B	4822 216 90177	X-deflection coefficients
U3C	4822 216 90078	X-deflection coefficients
U4A	4822 216 90176	Pre-amplifier
U4B	4822 216 90079	Y-deflection coefficients
U4C	4822 216 90081	Y-deflection coefficients
U5A	4822 216 90082	Base resistors
U6A	4822 216 90083	Shunt plate
U7	4822 216 90084	Power supply
U8A	4822 216 90178	Final amplifier
U9A	4822 216 90086	Step generator
U9B	4822 216 90087	Ring counter
U11A	4822 216 90088	H.T. circuit
U13	4822 216 90089	Adjusting circuit
RE801	4822 280 70032	Relay
VL1	4822 253 30025	2A, delayed action Fuse
VL2	4822 253 30025	2A, delayed action Fuse
VL3	4822 252 20001	125° C Fuse

TRANSISTORS

Item	Ordering code	Type	Item	Ordering code	Type
TS101	4822 130 40184	BC107	TS716	4822 130 40184	BC107
TS102	4822 130 40184	BC107	TS801	4822 130 40201	2N3703
TS103	4822 130 40184	BC107	TS802	4822 130 40184	BC107
TS104	4822 130 40444	2N2905	TS803	4822 130 40201	2N3703
TS105	4822 130 40389	BFY67	TS804	4822 130 40184	BC107
TS106	4822 130 40444	2N2905	TS805	4822 130 40184	BC107
TS131	4822 130 40184	BC107	TS806	4822 130 40444	2N2905
TS132	4822 130 40184	BC107	TS807	4822 130 40356	BFY51
TS133	4822 130 40184	BC107	TS808	4822 130 40462	BFY52
TS134	4822 130 40444	2N2905	TS809	4822 130 40444	2N2905
TS135	4822 130 40389	BFY67	TS810	4822 130 40211	2N3713
TS136	4822 130 40444	2N2905	TS811	4822 130 40211	2N3713
TS161	4822 130 40184	BC107	TS812	4822 130 40444	2N2905
TS162	4822 130 40354	BC177	TS813	4822 130 40184	BC107
TS191	4822 130 40184	BC107	TS814	4822 130 40139	3N124
TS201	4822 130 40354	BC177	TS901	4822 130 40184	BC107
TS202	4822 130 40184	BV107	TS902	4822 130 40184	BC107
TS203	4822 130 40282	ASZ18	TS903	4822 130 40184	BC107
TS301	4822 130 40139	3N124*	TS904	4822 130 40184	BC107
TS302	4822 130 40184	BC107	TS905	4822 130 40354	BC177
TS303	4822 130 40354	BC177	TS906	4822 130 40184	BC107
TS304	4822 130 40184	BC107	TS907	4832 130 40184	BC107
TS305	4822 130 40184	BC107	TS908	4822 130 40354	BC177
TS306	4822 130 40139	3N124*	TS911	4822 130 40184	BC107
TS307	4822 130 40184	BC107	TS912	4822 130 40184	BC107
TS321	4822 130 40184	BC107	TS913	4822 130 40354	BC177
TS322	4822 130 40184	BC107	TS914	4822 130 40184	BC107
TS401	4822 130 40139	3N124*	TS915	4822 130 50354	BC177
TS402	4822 130 40184	BC107	TS916	4822 130 40184	BC107
TS403	4822 130 40354	BC177	TS917	4822 130 40354	BC177
TS404	4822 130 40184	BC107	TS918	4822 130 40184	BC107
TS405	4822 130 40184	BC107	TS919	4822 130 40354	BC177
TS406	4822 130 40139	3N124*	TS920	4822 130 40184	BC107
TS407	4822 130 40354	BC177	TS921	4822 130 40354	BC177
TS701	4822 130 40136	BDY11	TS922	4822 130 40184	BC107
TS702	4822 130 40354	BC177	TS923	4822 130 40354	BC177
TS703	4822 130 40354	BC177	TS924	3822 130 40184	BC107
TS704	4822 130 40184	BC107	TS925	4822 130 40354	BC177
TS705	4822 130 40184	BC107	TS926	4822 130 40184	BC107
TS706	4822 130 40184	BC107	TS927	4822 130 40354	BC177
TS711	4822 130 40136	BDY11	TS1601-2	4822 130 40282	ASZ18*
TS713	4822 130 40184	BC107	TS1701-2	4822 130 40282	ASZ18*
TS712	4822 130 40184	BC107			
TS714	4822 130 40354	BC177			
TS715	4822 130 40184	BC107			

* When one selected FET of one of these pairs should be replaced, the whole pair should be replaced.

DIODES

Item	Ordering code	Type	Item	Ordering code	Type
GR1	4822 130 30198	KBS01(2)	GR712	4822 130 30273	BAX16
GR92	4822 130 30281	OA91	GR713	4822 130 30273	BAX16
GR93	4822 130 30245	BZY63	GR714	4822 130 30193	BZY88/C5V6
GR101	4822 130 30273	BAX16*	GR716	4822 130 30195	BYX10
GR102	4822 130 30273	BAX16*	GR721	4822 130 30273	BAX16
GR103	4822 130 30229	AAZ15	GR722	4822 130 30193	BZY88/C5V6
GR104	4822 130 30273	BAX16	GR724	4822 130 30195	BYX10
GR105	4822 130 30084	AAZ18	GR801	4822 130 30273	BAX16
GR106	4822 130 30084	AAZ18	GR802	4822 130 30273	BAX16
GR131	4822 130 30273	BAX16*	GR803	4822 130 30196	BZY60
GR132	4822 130 30273	BAX16*	GR804	4822 130 30273	BAX16
GR133	4822 130 30229	AAZ15	GR805	4822 130 30273	BAX16
GR134	4822 130 30273	BAX16	GR901	4822 130 30273	BAX16
GR135	4822 130 30084	AAZ18	GR902	4822 130 30273	BAX16
GR136	4822 130 30084	AAZ18	GR903	4822 130 30273	BAX16
GR201	4822 130 30195	BYX10	GR904	4822 130 30273	BAX16
GR202	4822 130 30195	BYX10	GR905	4822 130 30273	BAX16
GR203	4822 130 30296	BY140	GR906	4822 130 30273	BAX16
GR205	4822 130 30296	BY140	GR907	4822 130 30273	BAX16
GR301	4822 130 30303	BAY32	GR908	4822 130 30273	BAX16
GR302	4822 130 30303	BAY32	GR909	4822 130 30191	OA95
GR303	4822 130 30189	BA114	GR910	4822 130 30273	BAX16
GR304	4822 130 30132	BZY59	GR911	4822 130 30273	BAX16
GR305	4822 130 30132	BZY59	GR912	4822 130 30273	BAX16
GR306	4822 130 30189	BA114	GR913	4822 130 30273	BAX16
GR307	4822 130 30303	BAY32	GR914	4822 130 30273	BAX16
GR308	4822 130 30303	BAY32	GR915	4822 130 30273	BAX16
GR309	4822 130 30189	BA114	GR916	4822 130 30191	OA95
GR310	4822 130 30189	BA114	GR917	4822 130 30191	OA95
GR311	4822 130 30132	BZY59	GR918	4822 130 30191	OA95
GR401	4822 130 30303	BAY32	GR919	4822 130 30191	OA95
GR402	4822 130 30303	BAY32	GR920	4822 130 30191	OA95
GR403	4822 130 30189	BA114	GR923 . . . 40	4822 130 30191	OA95
GR404	4822 130 30132	BZY59	GR1101	4822 130 30296	BY140
GR405	4822 130 30132	BZY59	GR1301	4822 130 30273	BAX16
GR406	4822 130 30189	BA114	GR1501	4822 130 30195	BYX10
GR407	4822 130 30303	ZAY32	GR1502	4822 130 30195	BYX10
GR408	4822 130 30303	BAY32	GR1503	4822 130 30277	BYX28/400R
GR409	4822 130 30189	BA114	GR1504	4822 130 30277	BYX28/400R
GR410	4822 130 30189	BA114			
GR421	4822 130 30276	BYX20/200R			
GR422	4822 130 30276	BYX20/200			
GR701	4822 130 30198	KBS01(2)			
GR702	4822 130 30279	BY123			
GR711	4822 130 30273	BAX16			

* These components are selected. Please refer to the selecting procedure at the end of this chapter.

Selection procedures for semi-conductors

— When replacing the power transistors TS1601, 1602, 1701 and 1702, the replacements should be selected for a leakage current ≤ 10 mA at a V_{CE} -voltage of 50 V.

— When replacing the diodes GR101, 102, 131 and 132, the replacements should be selected for a voltage U_a (see diagram) between 490 and 520 mV, which corresponds to an indication of 90 to 120 mV on the voltmeter.

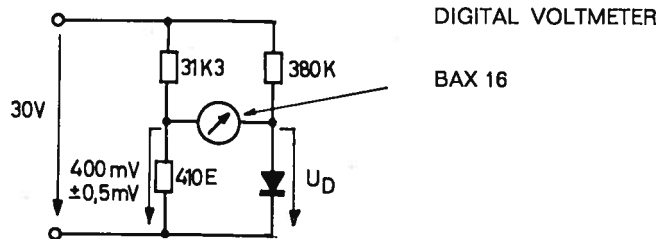

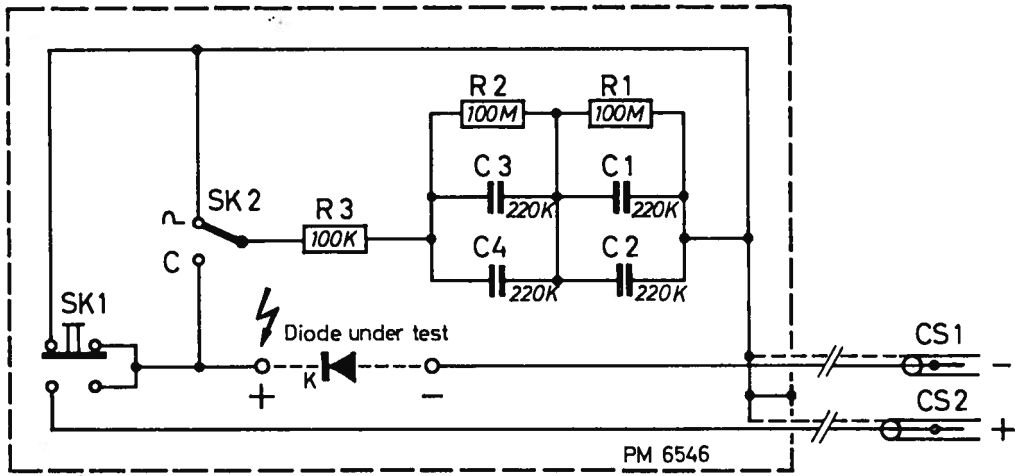

Fig. 87. Diagram PM 6546

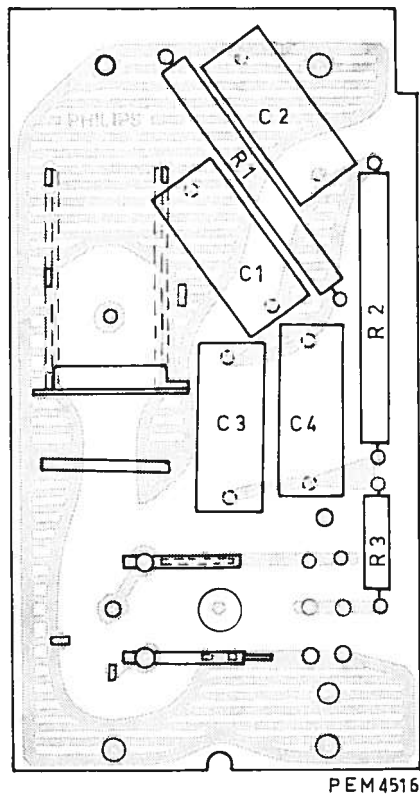
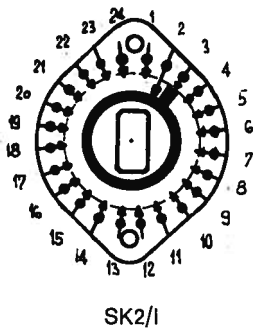
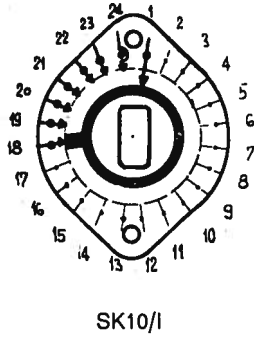

Fig. 88. Printed wiring board PM 6546



SK2/I



SK10/I

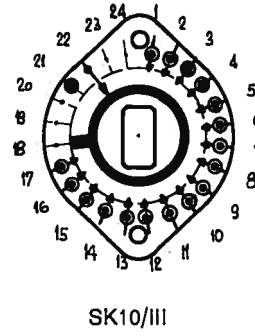

SK10/III

SK2/II

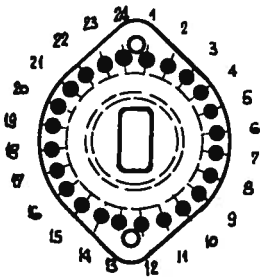

SK10/II

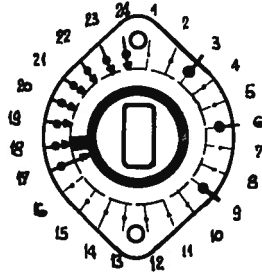

SK10/IV

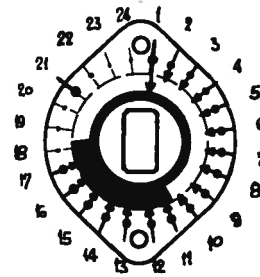
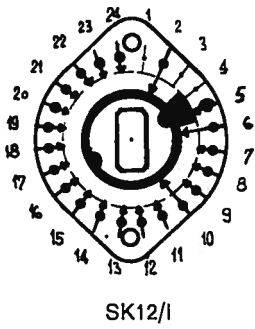
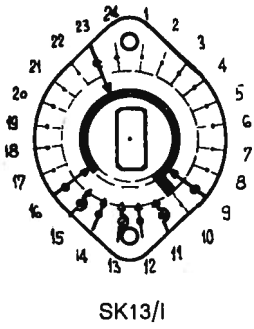

Fig. 89. Switch wafers SK2

Fig. 90. Switch wafers SK10



SK12/I



SK13/I

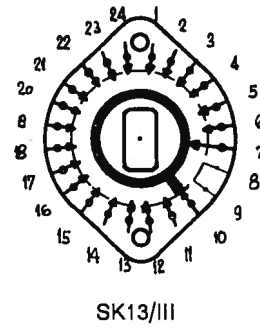

SK13/III

SK12/II

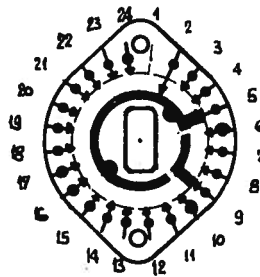

SK13/II

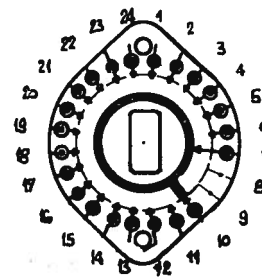

SK13/IV

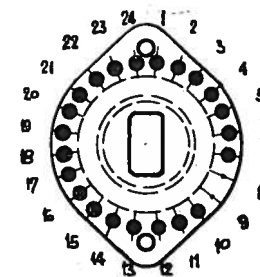

Fig. 91. Switch wafers SK12

Fig. 92. Switch wafers SK13

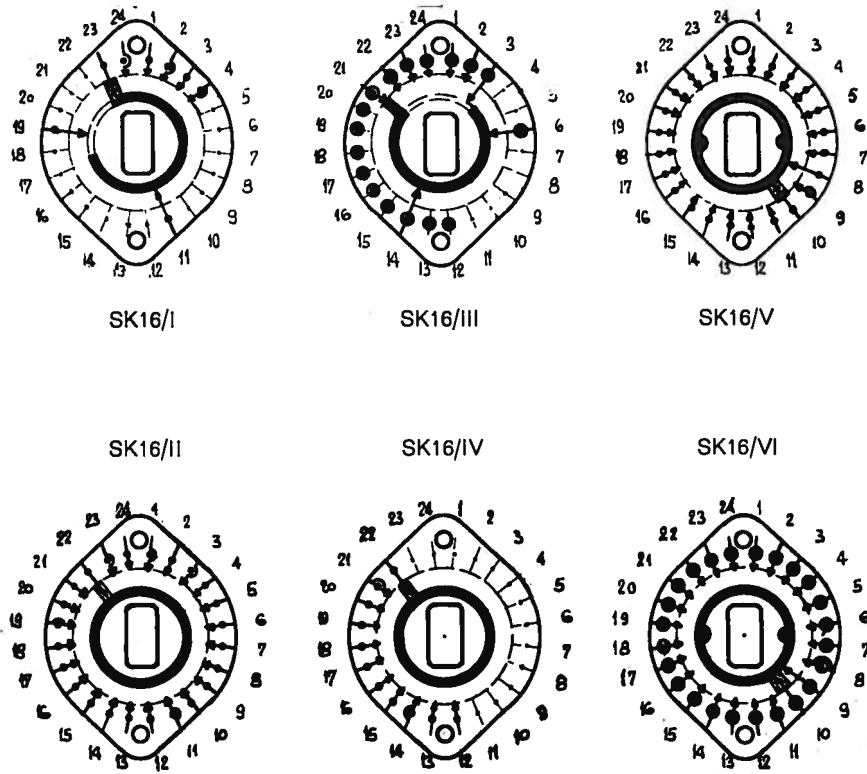

Fig. 93. Switch wafers SK16

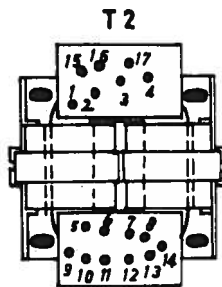

Fig. 94. Connection diagram for mains transformer T2

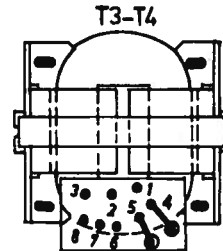

Fig. 95. Connection diagram for collector transformers T3 and T4

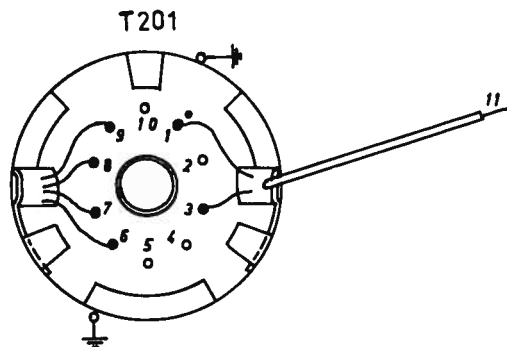

Fig. 96. Connection diagram for H.T. transformer T201

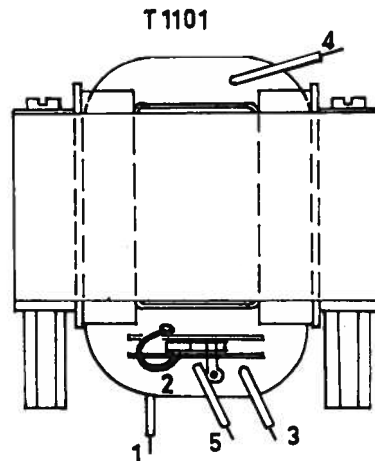
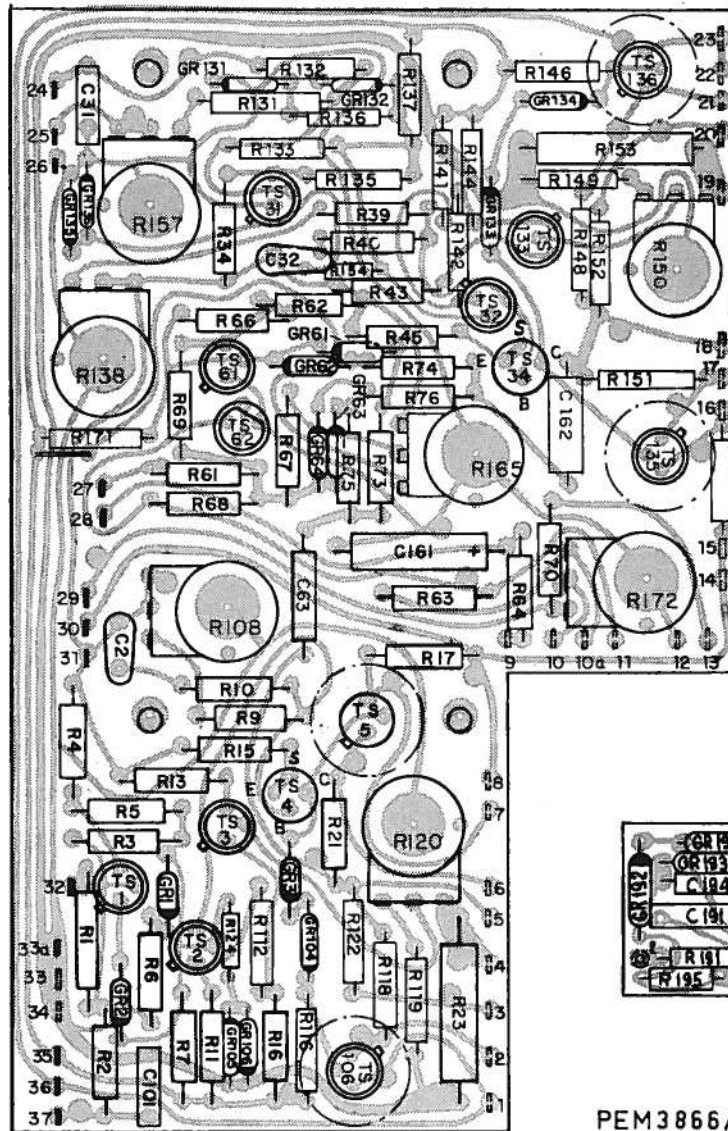
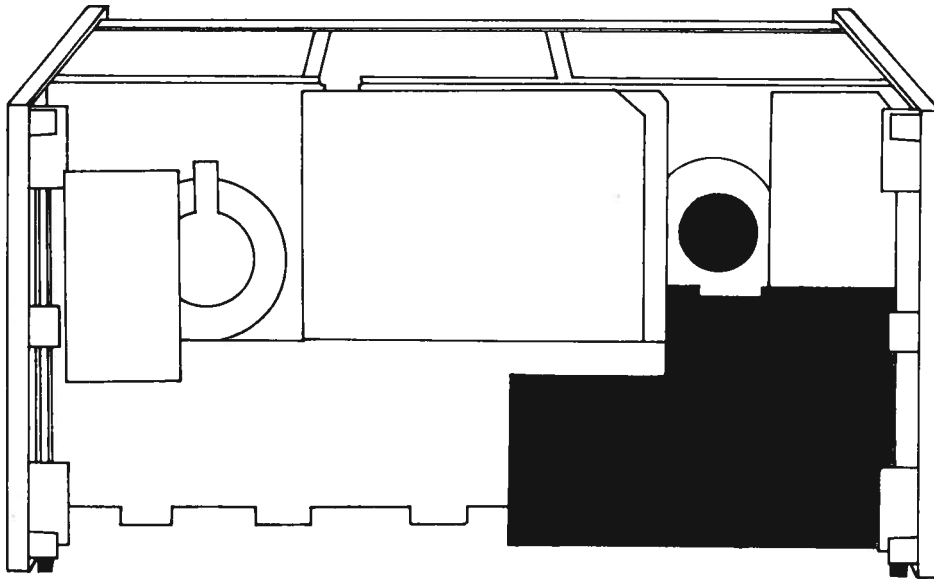

Fig. 97. Connection diagram for H.T. transformer T1101



PEM3866A

Fig. 98. Printed wiring board U1, final amplifier, and U1A intensity control

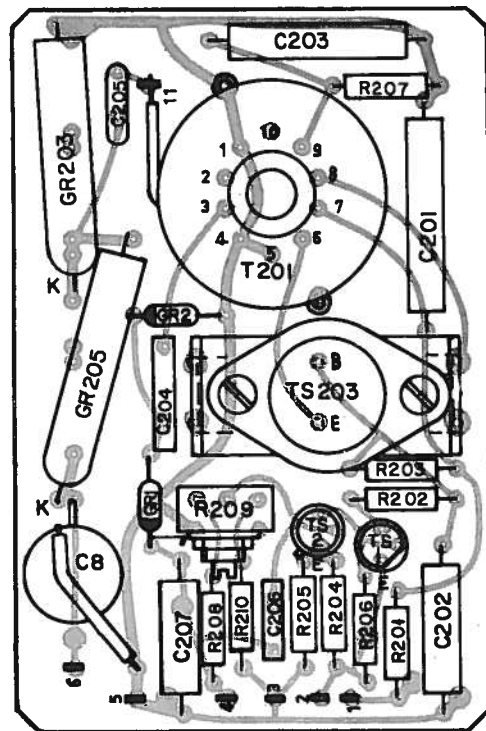
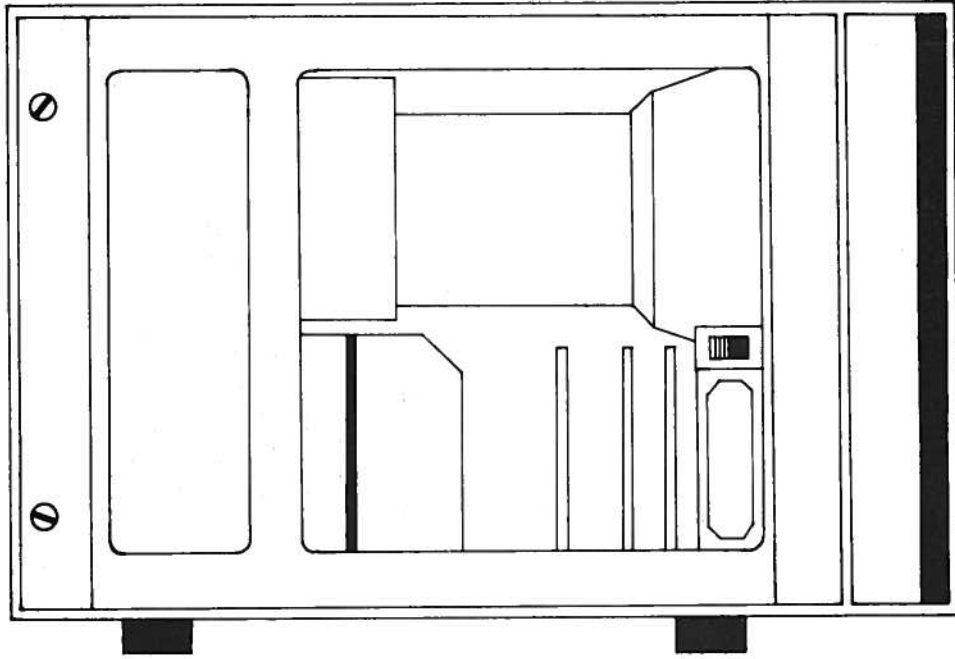
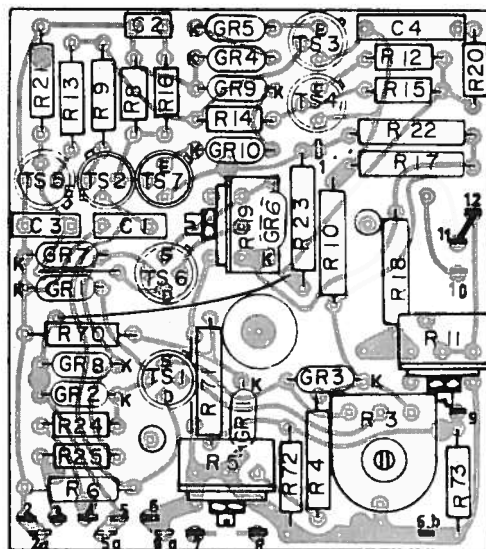
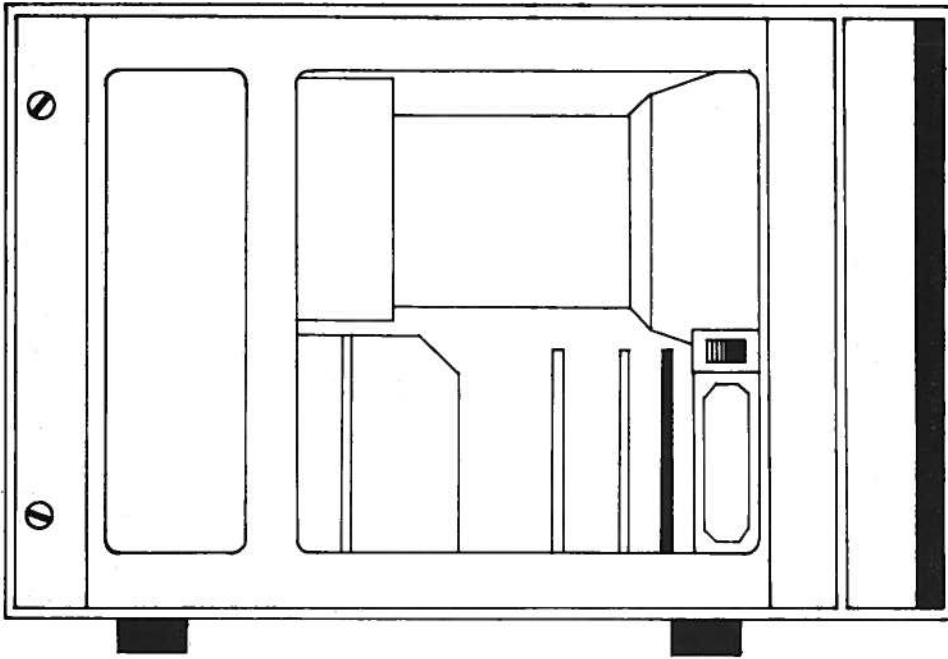
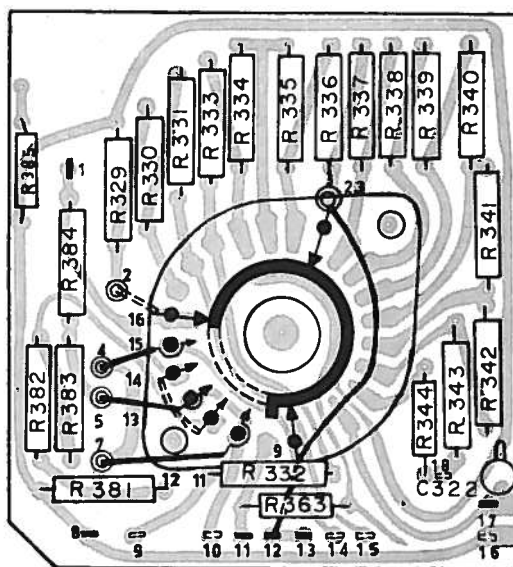
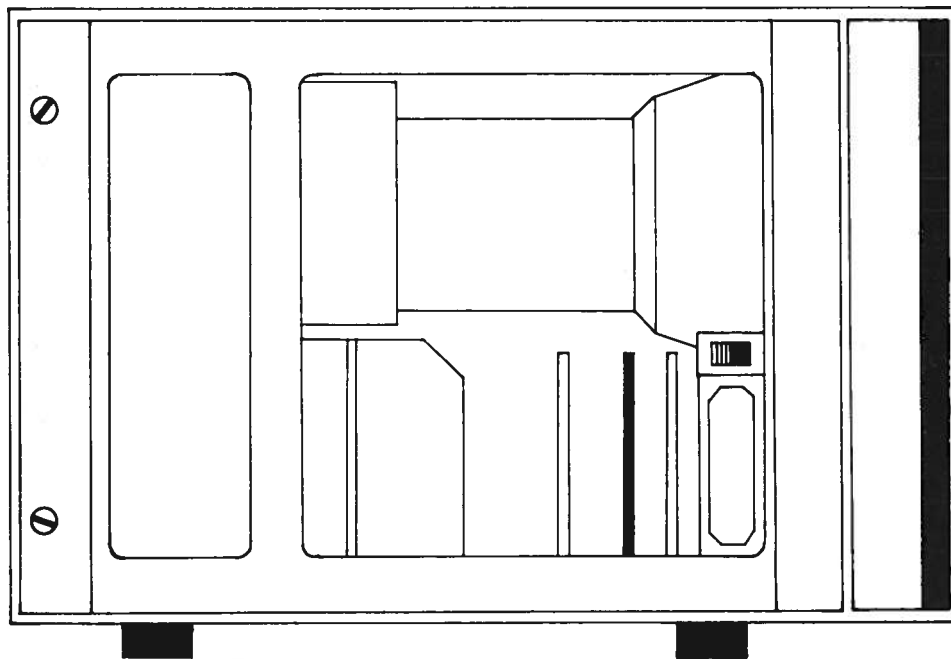

Fig. 99. Printed wiring board U2, H.T. circuit



PEM 3875

Fig. 100. Printed wiring board U3A, pre-amplifier



PEM 3883

Fig. 101. Printed wiring board U3B, X-deflection

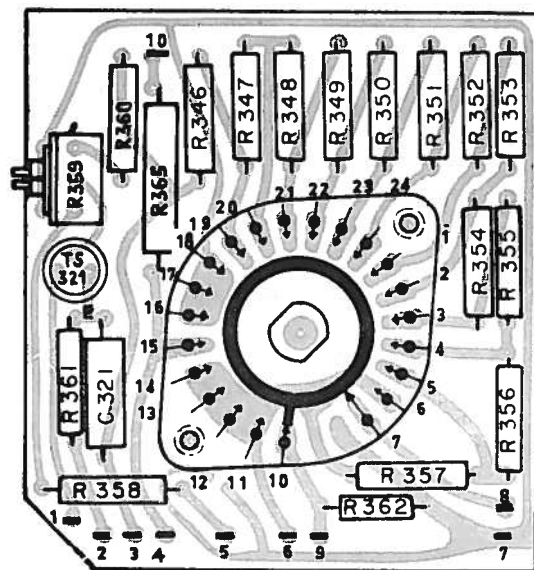
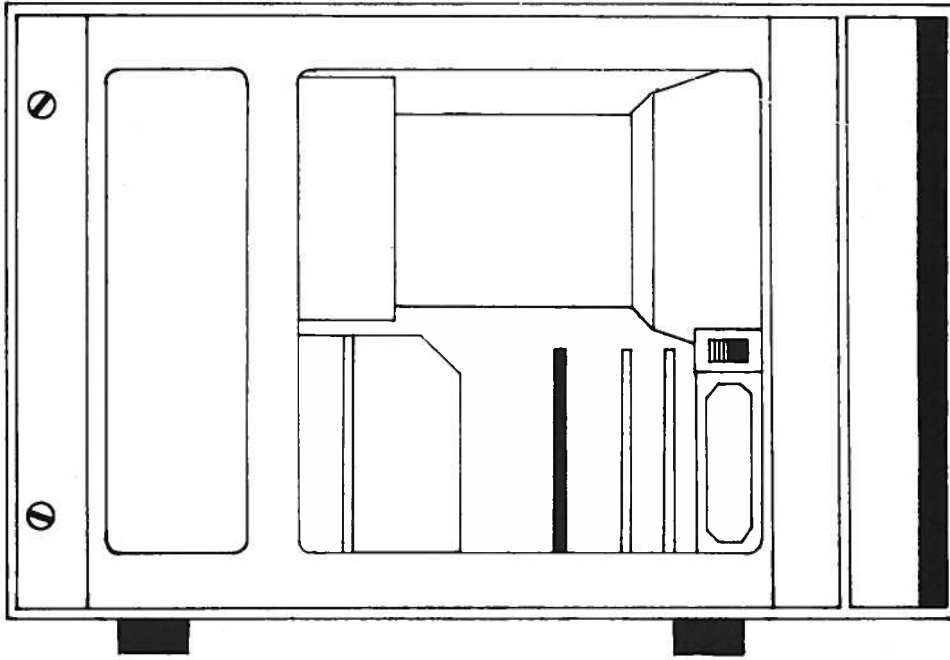

PEM 3877

Fig. 102. Printed wiring board U3C, X-deflection

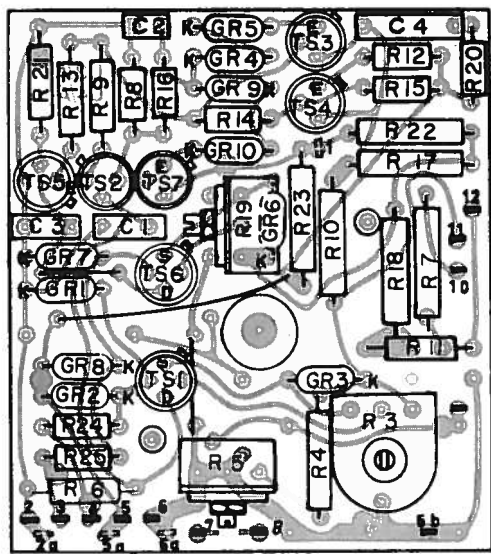
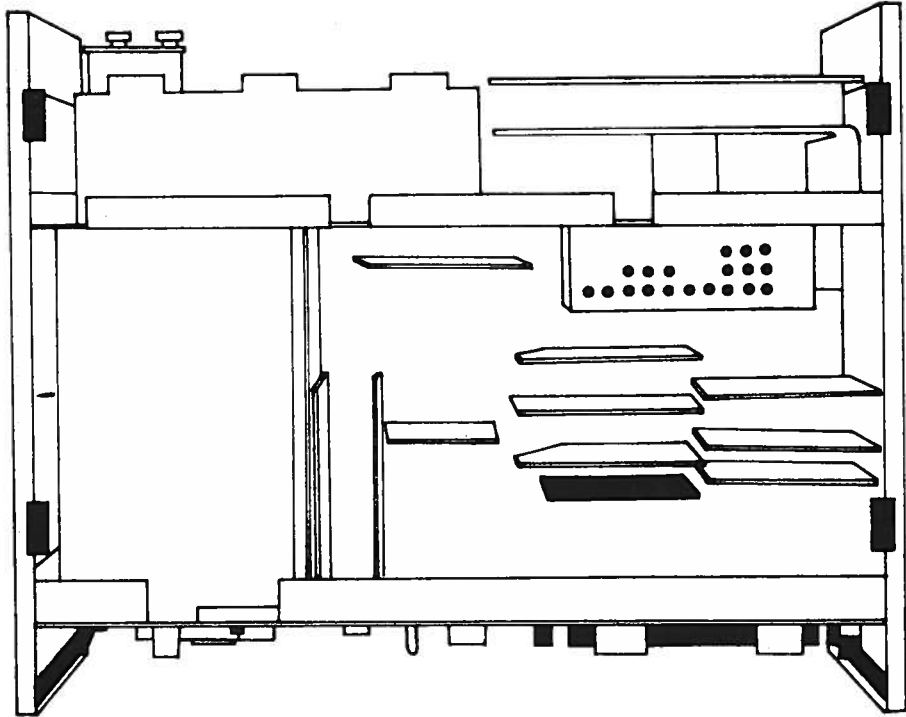

PEM 3876

Fig. 103. Printed wiring board U4A, pre-amplifier

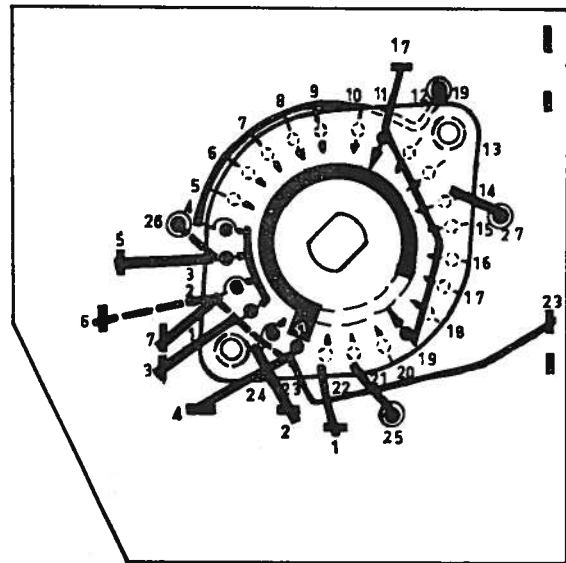
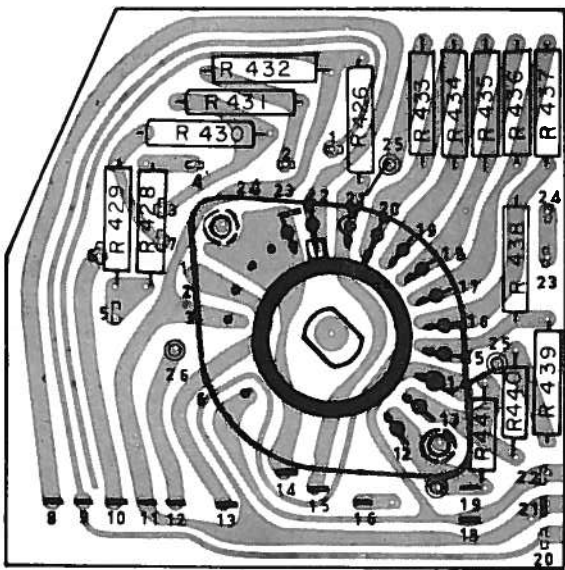
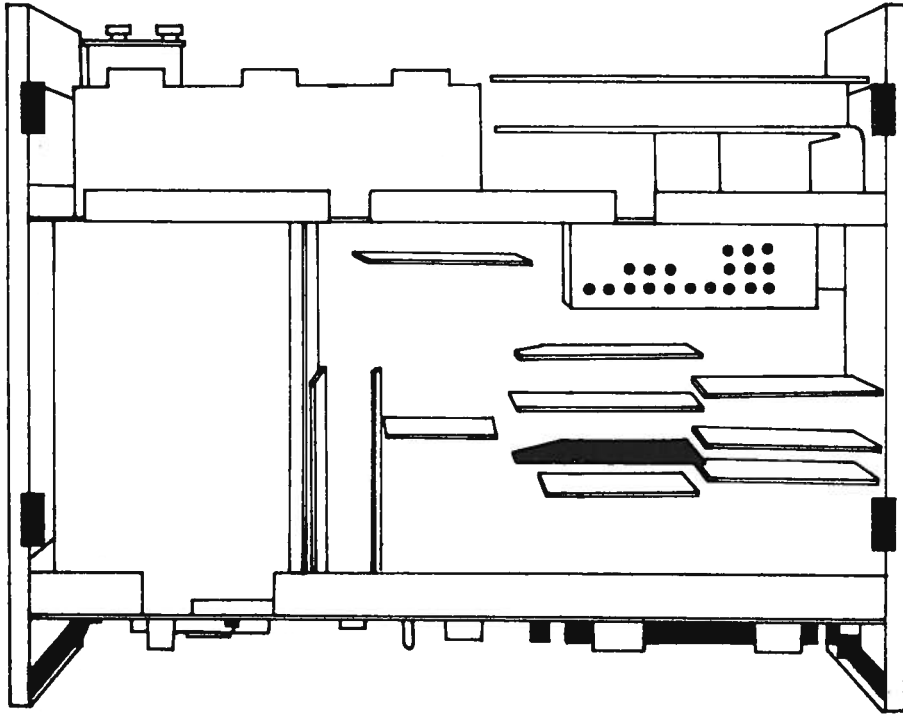

PEM 4873

Fig. 104. Printed wiring board U4B, Y-deflection

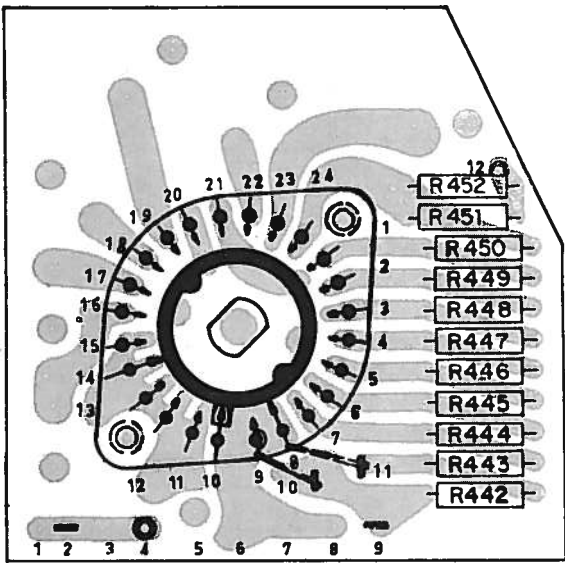
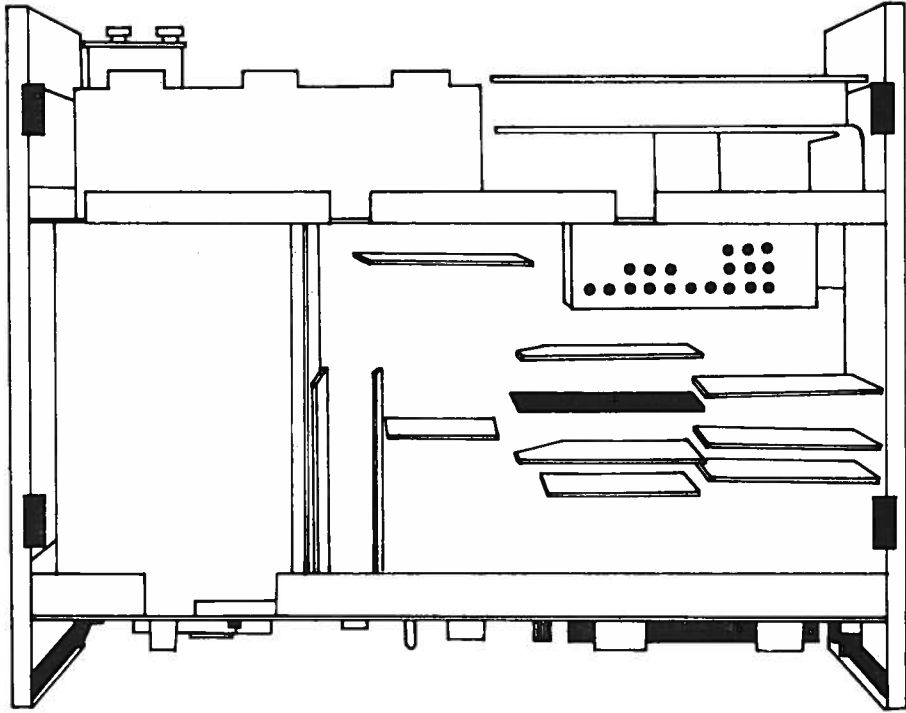

PEM 3881

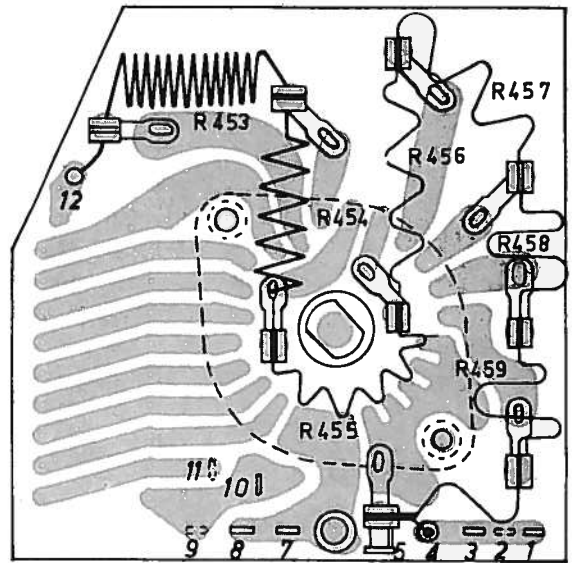

PEM 3882

Fig. 105. Printed wiring board U4C, Y-deflection

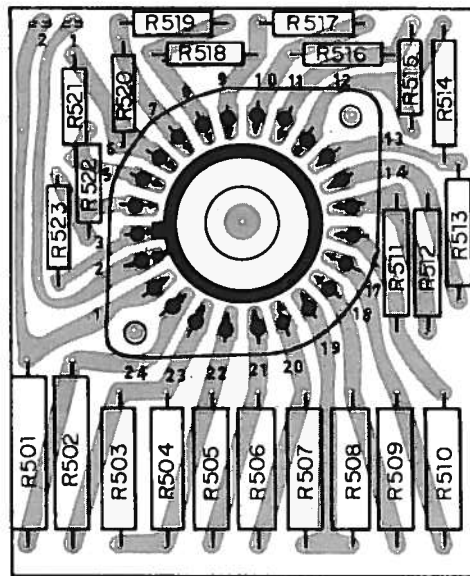
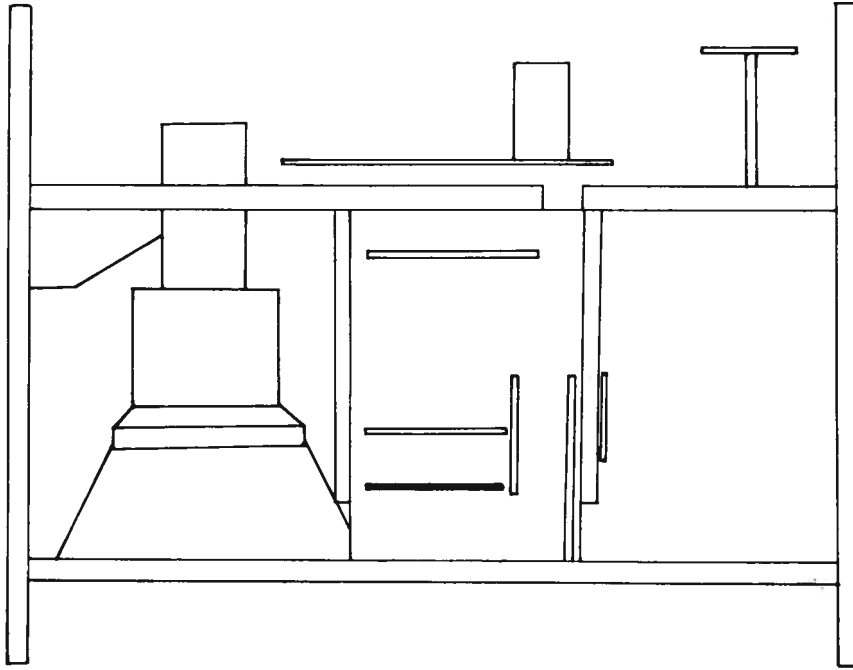

PEM 3869

Fig. 106. Printed wiring board U5A, base resistors

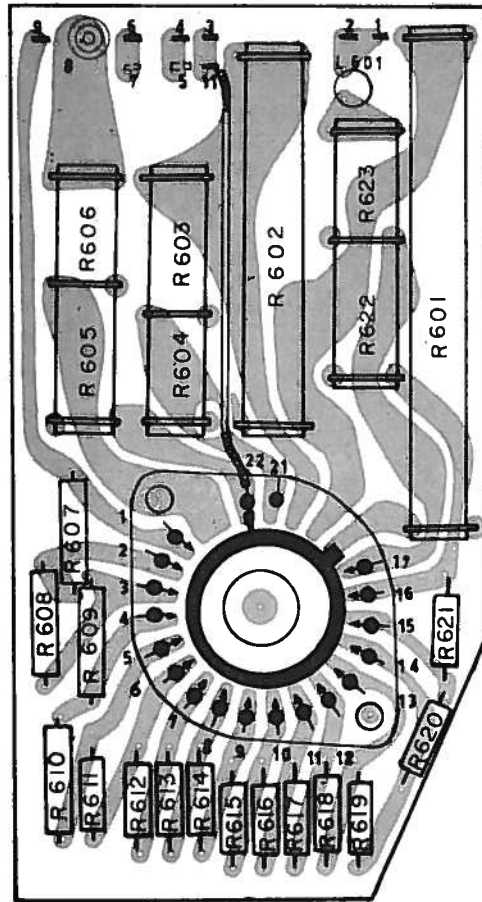
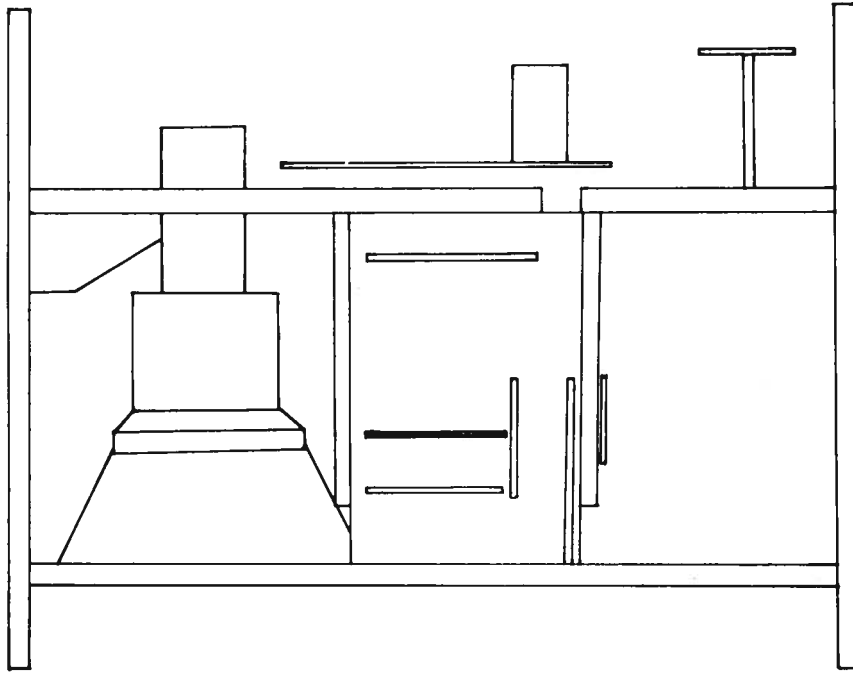

PEM 3870

Fig. 107. Printed wiring board U6A, shunt plate

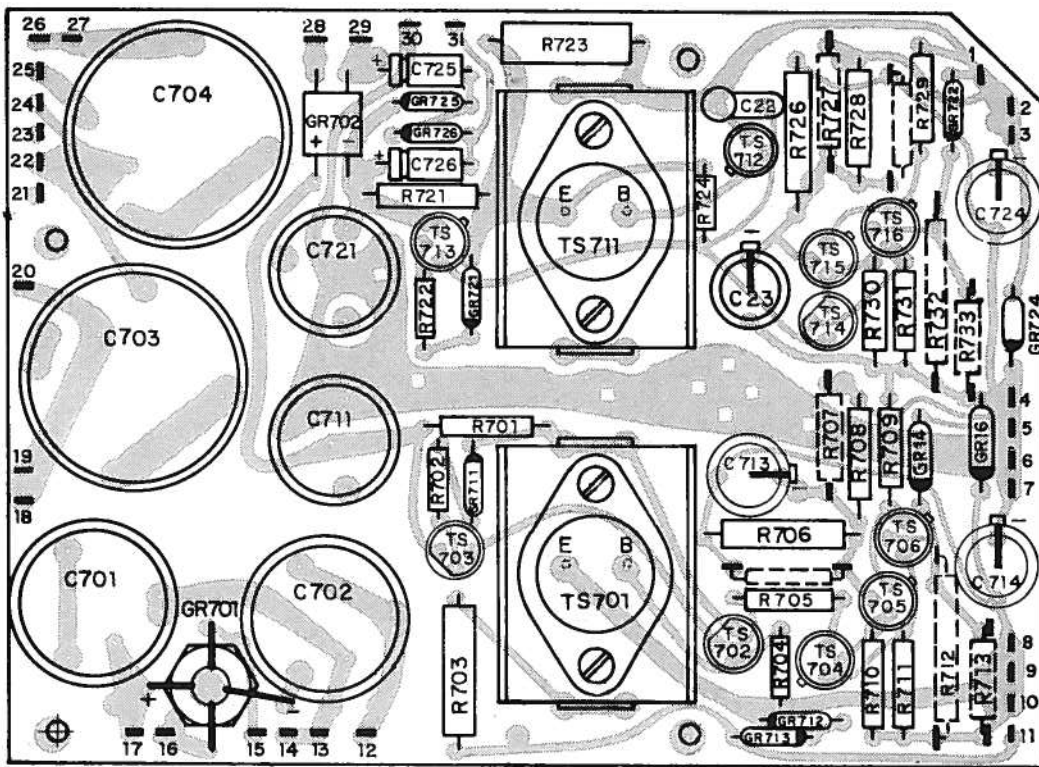
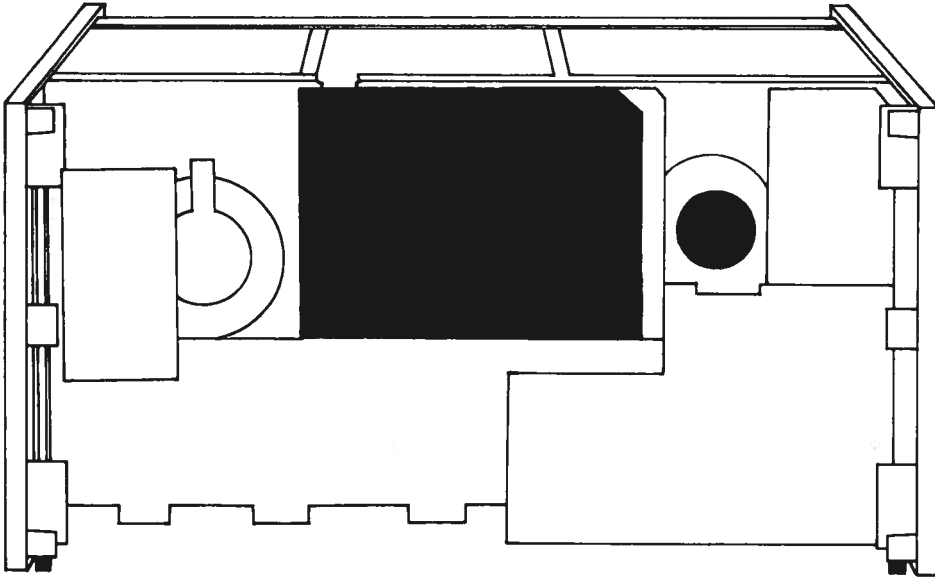

PEM 3865 A

Fig. 108. Printed wiring board U17, power supply

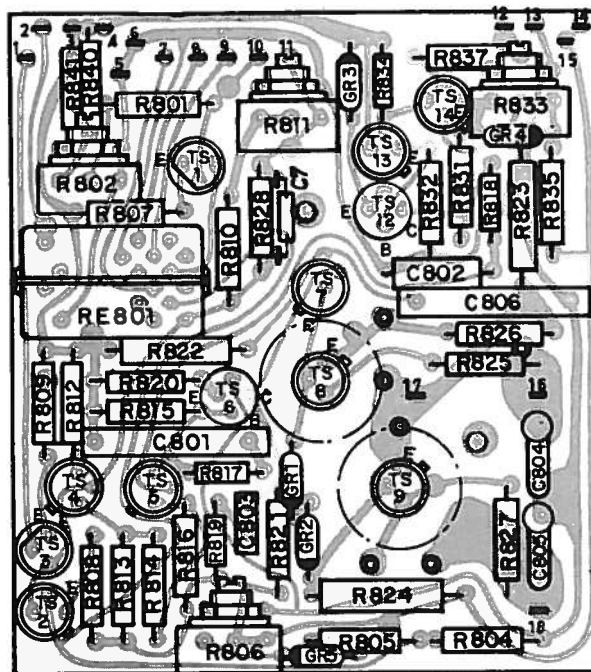
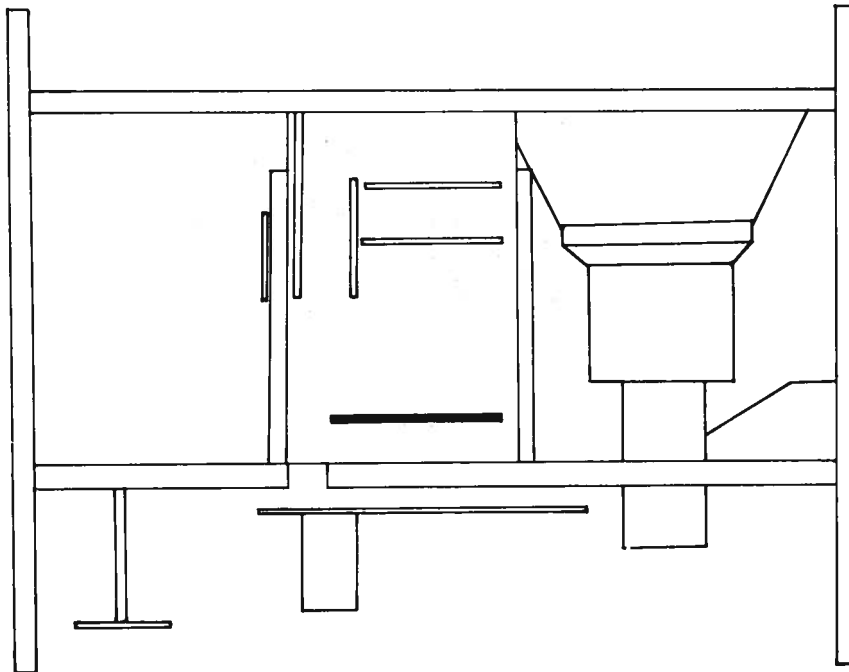

PEM 3868

Fig. 109. Printed wiring board U8A, final amplifier

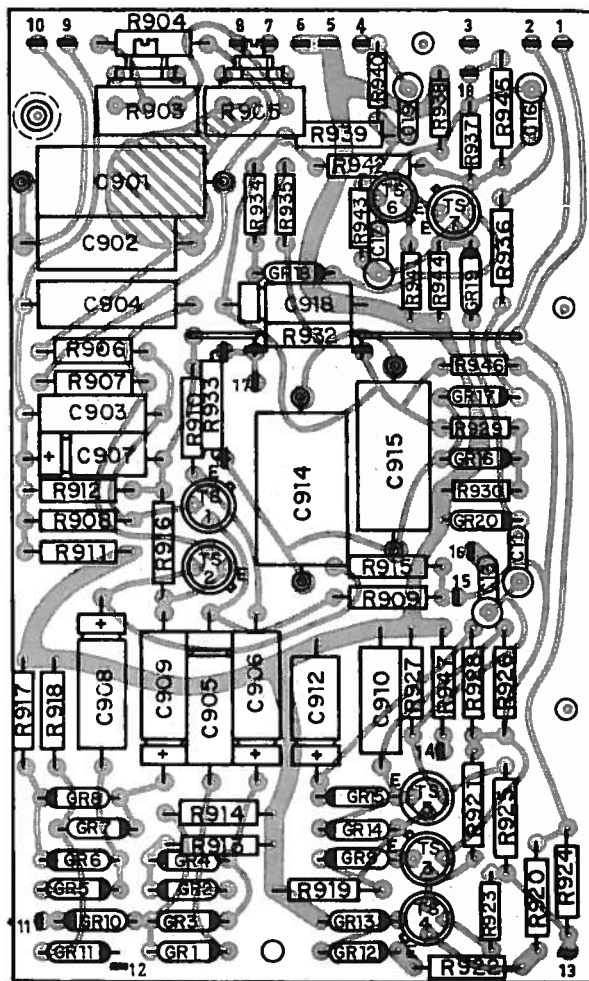
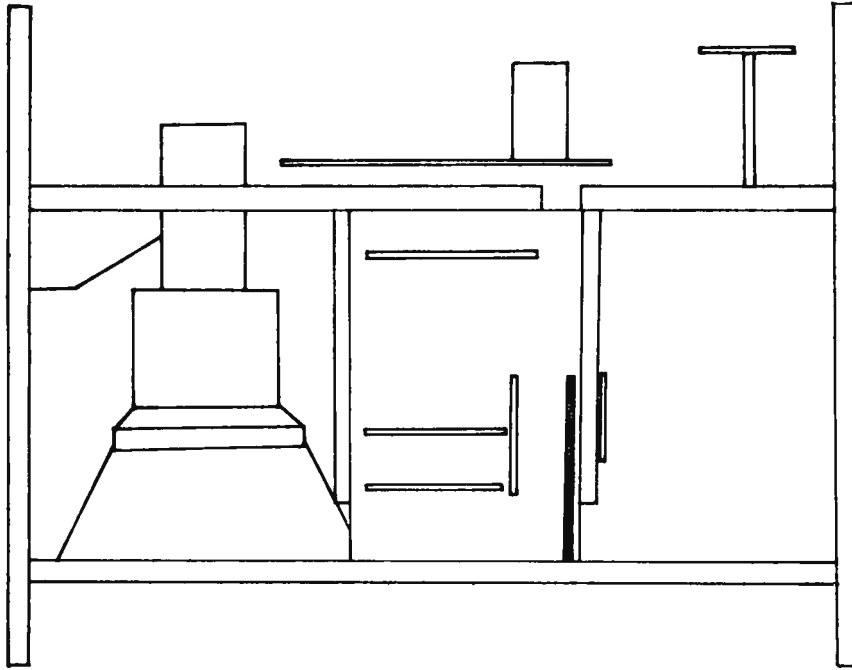

PEM3872

Fig. 110. Printed wiring board U9A, step generator

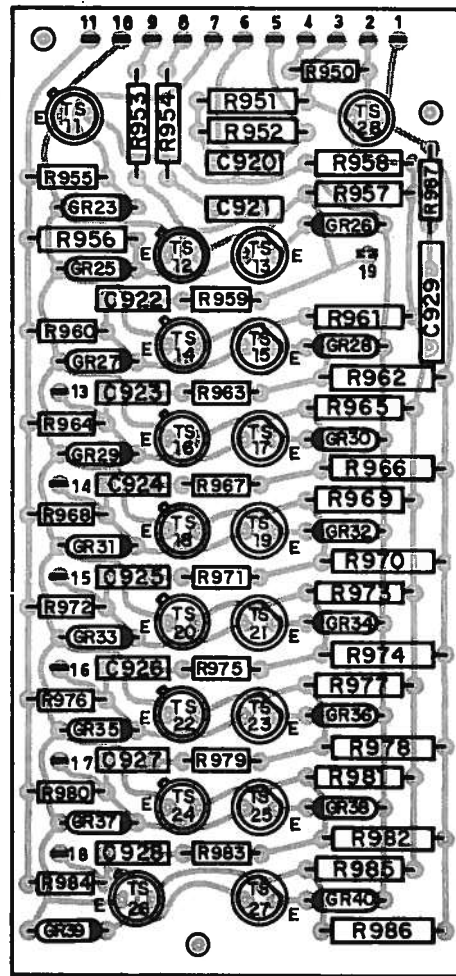
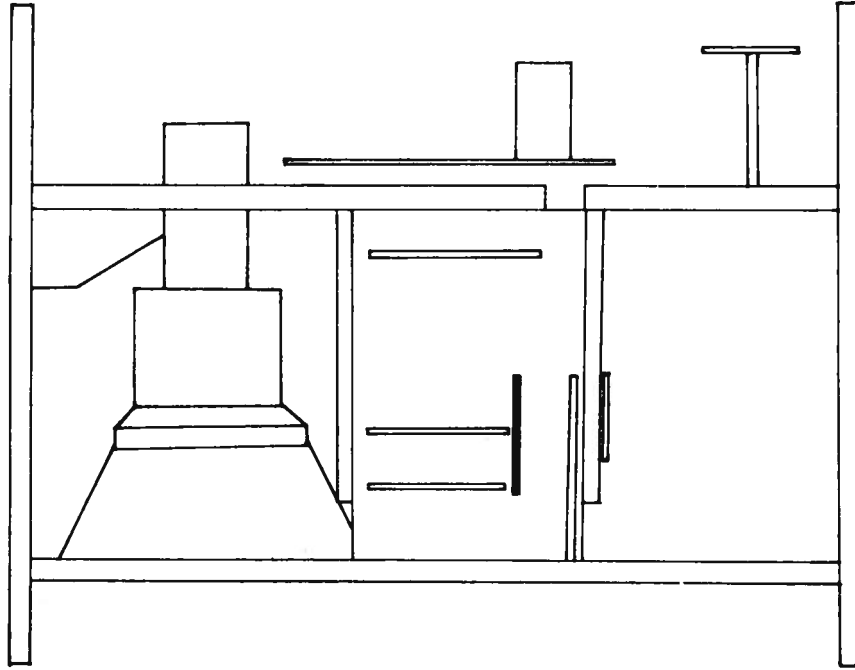

PEM 3871

Fig. 111. Printed wiring board U9B, ring-counter

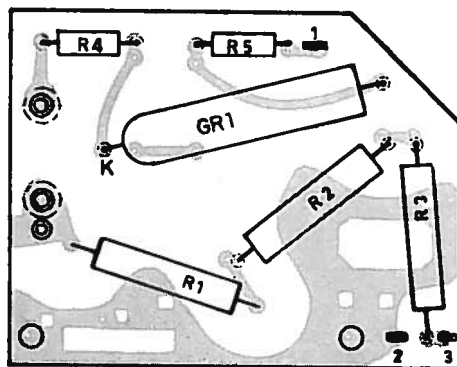
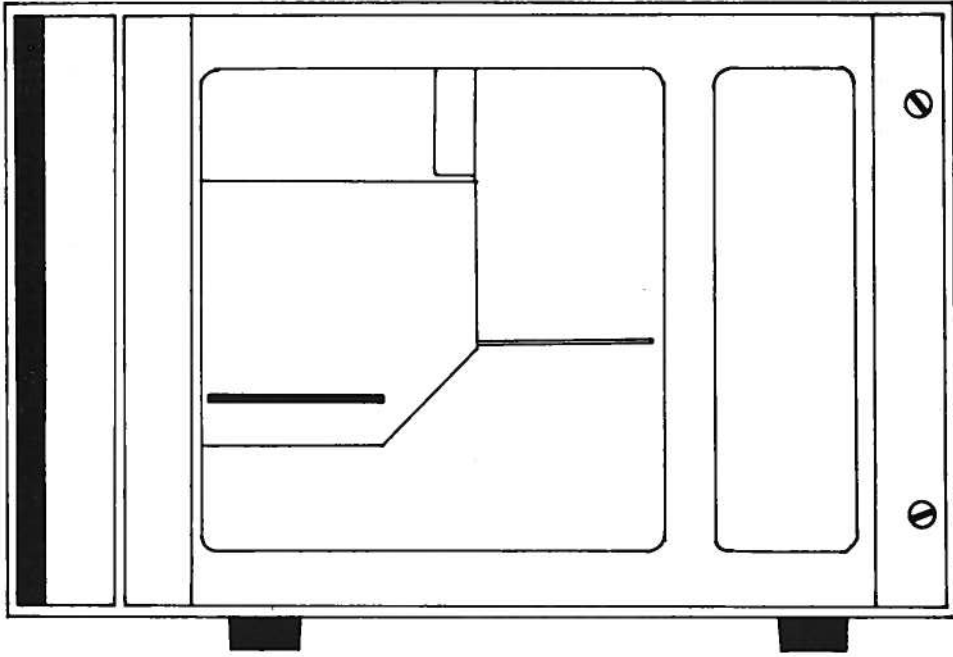

PEM 3878

Fig. 112. Printed wiring board U11A, high-tension unit

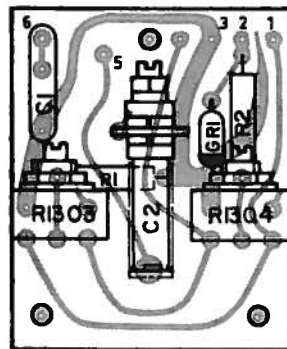
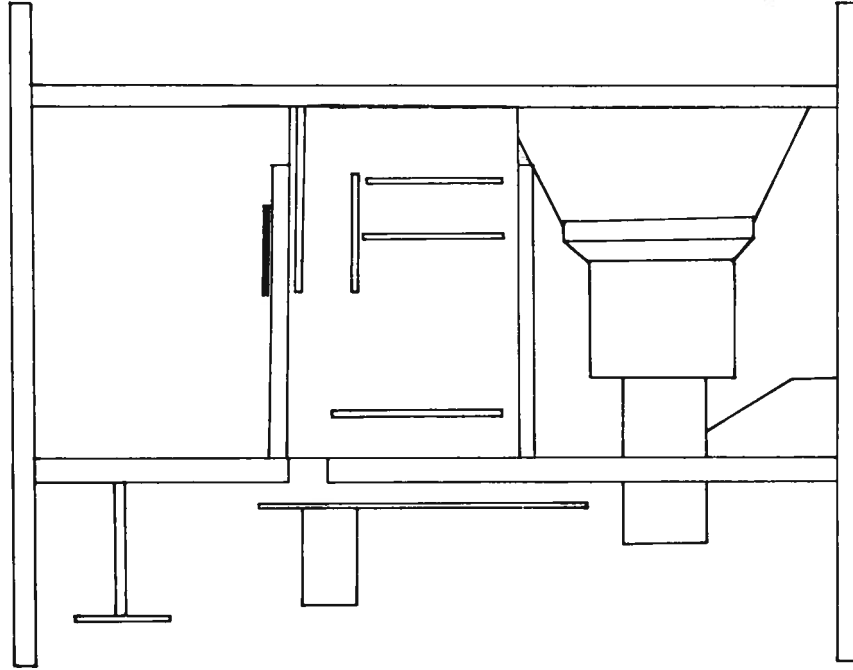

PEM 3874

Fig. 113. Printed-wiring board U13, adjusting circuit

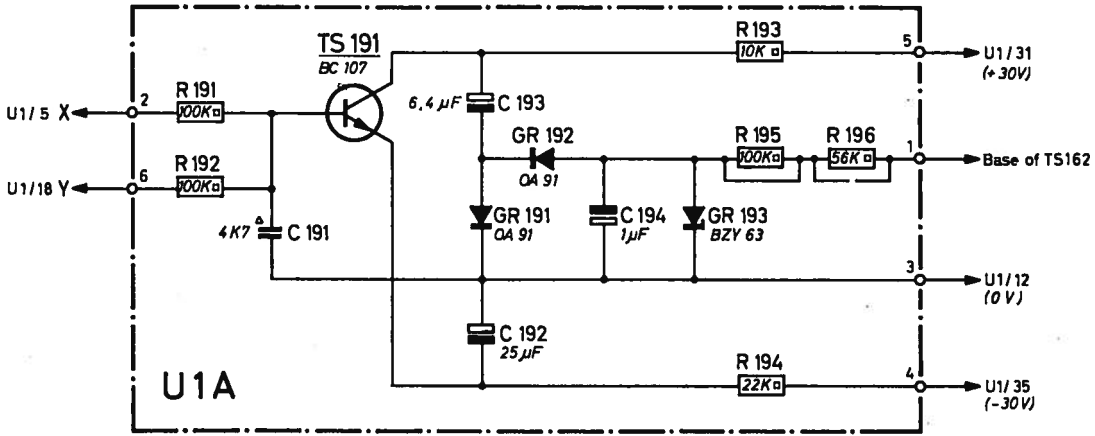
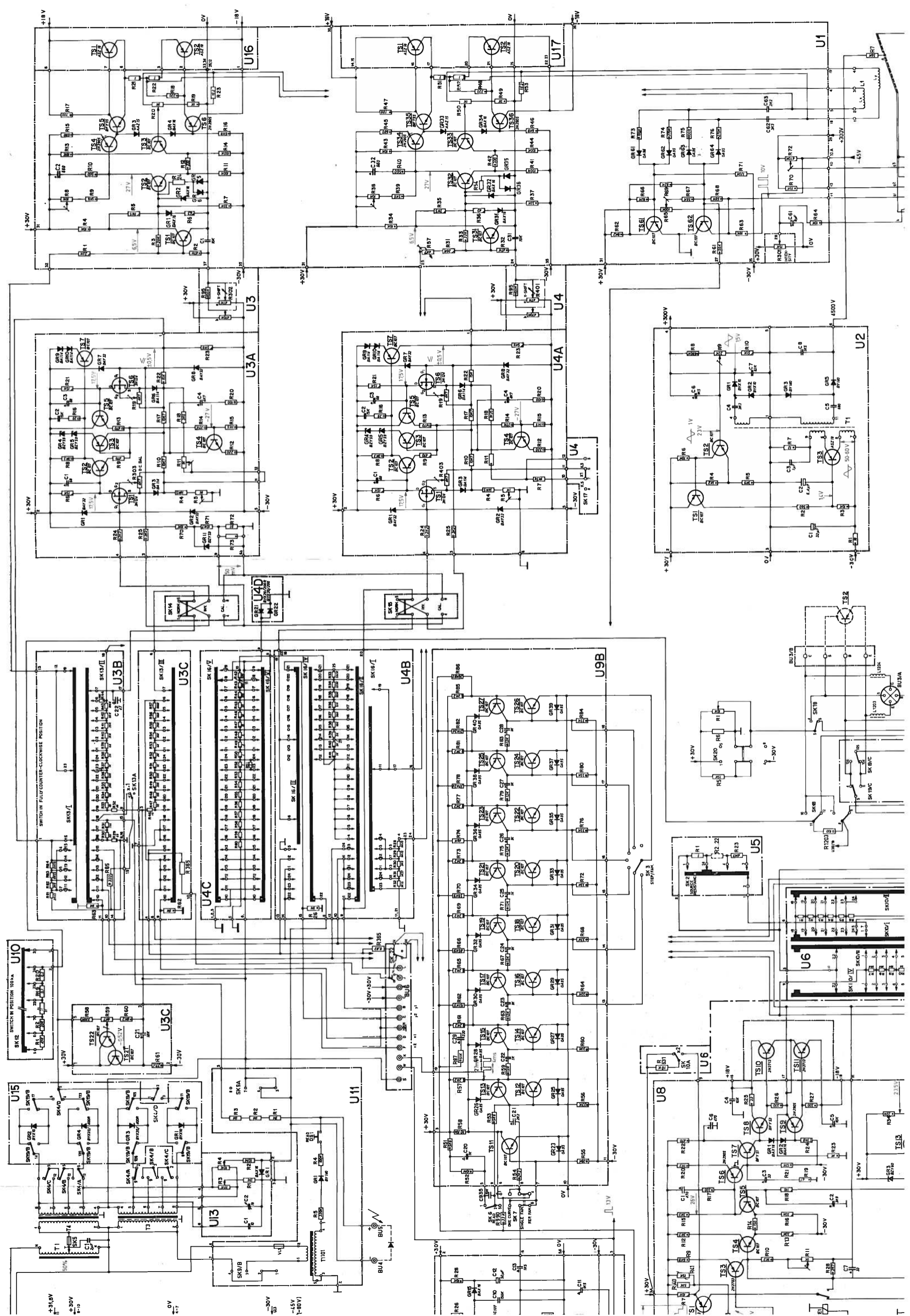

Fig. 114. Circuit diagram intensity limiter



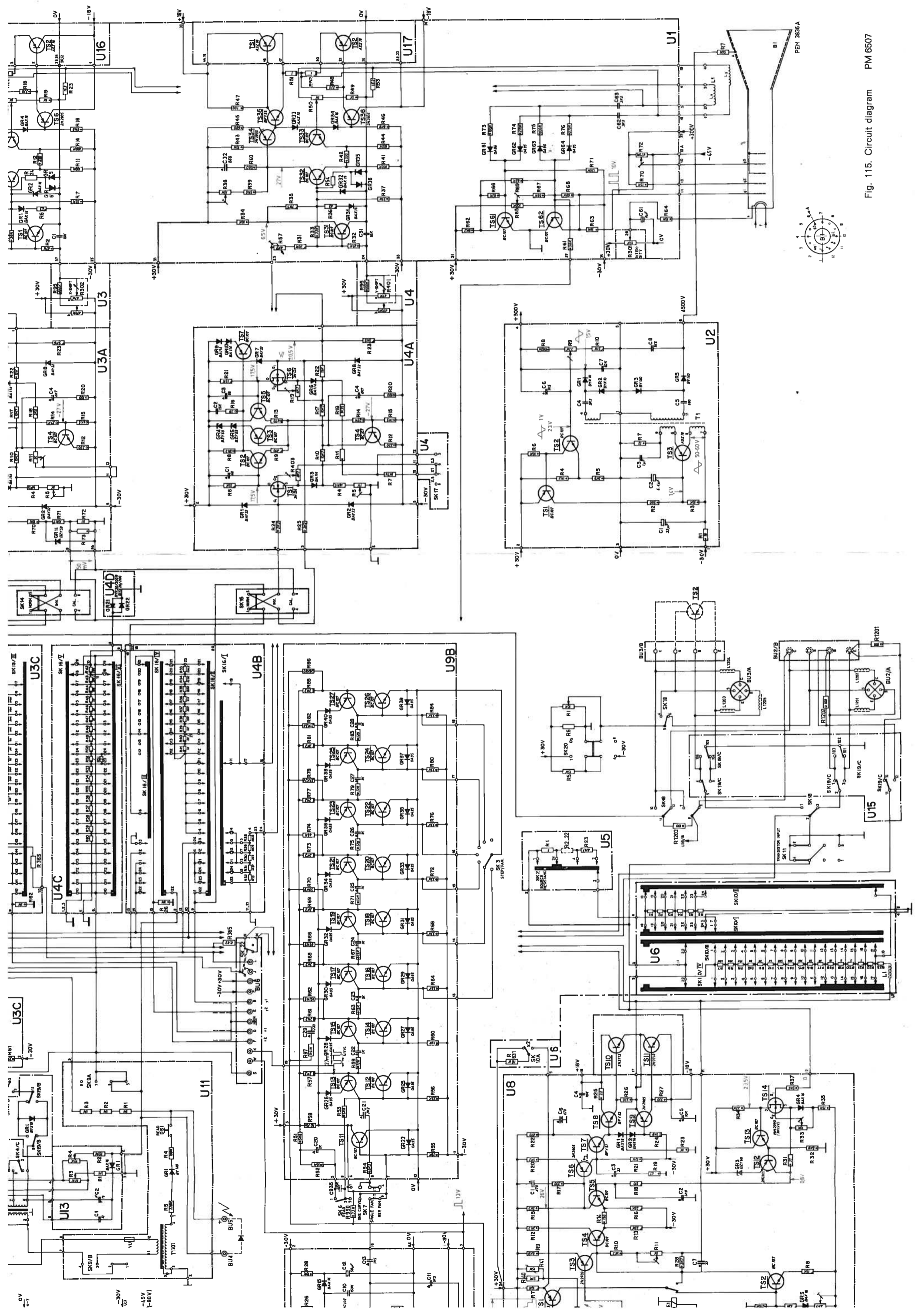

Fig. 115. Circuit diagram PM 6507

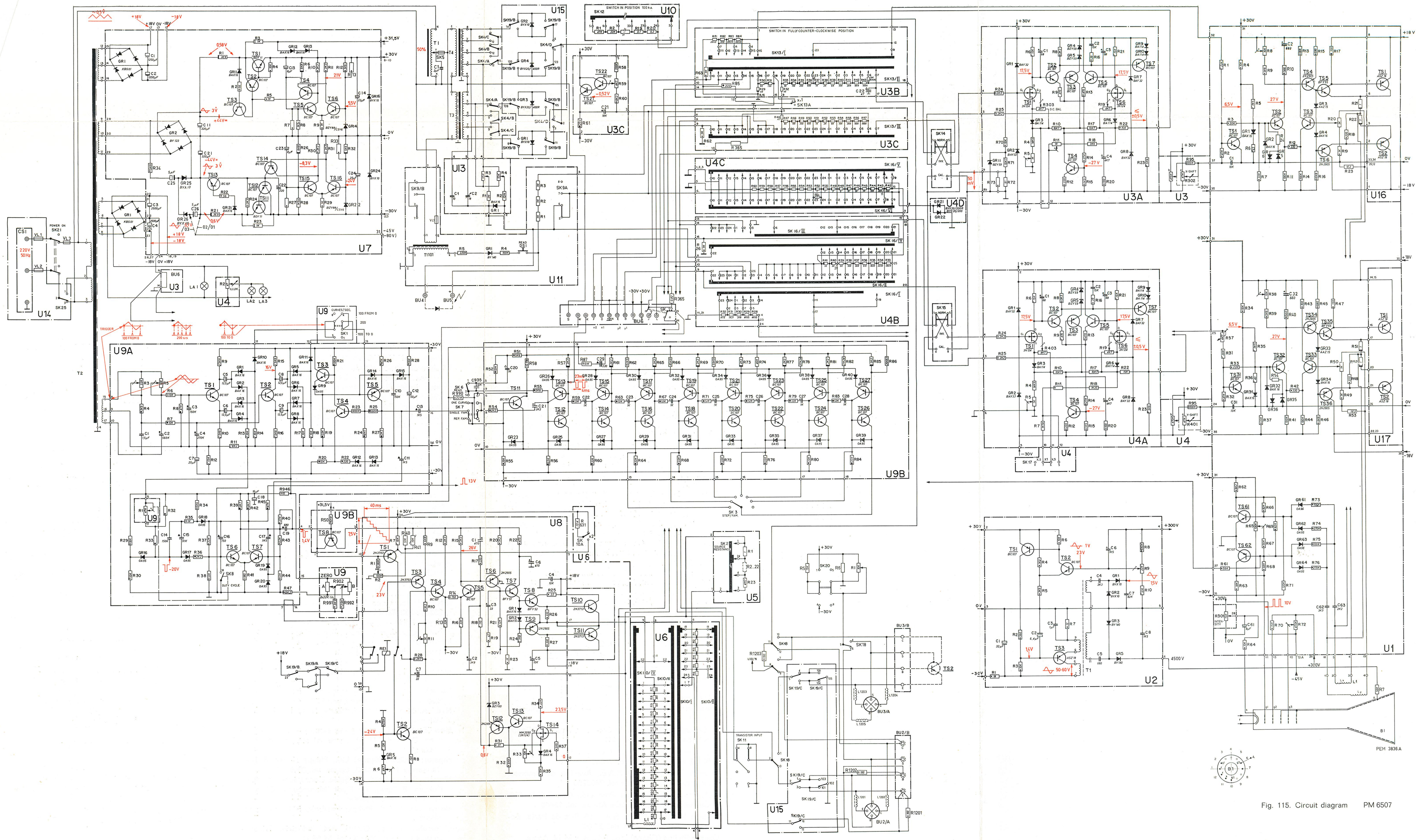

Fig. 115. Circuit diagram PM 6507