OPERATING INSTRUCTIONS

MODEL 45D VALVE TESTER

Taylor

CONTENTS

	Page
SECTION 1. General Information	3
SECTION 2. Principles of Operation	5
SECTION 3. Roller Selector Switch	11
SECTION 4. Cathode Ray Tube Adaptor	13
SECTION 5. Test Procedure	13
SECTION 6. Circuit Component List	17

ILLUSTRATIONS

Fig. 1. Rectifier 1	6
Fig. 2. Rectifier 2	6
Fig. 3. Diodes	7
Fig. 4. Filament Continuity	7
Fig. 5. Cathode Leakage	8
Fig. 6. Mutual Conductance	8
Fig. 7. Anode Current Measurement	10
Fig. 8. Circuit Diagram Valve Tester Model 45D	19

Whilst every care has been taken in the preparation of this publication to ensure that the data given is correct, the Company cannot accept any responsibility for damage caused to a valve under test, or the instrument, due to the inclusion of incorrect information.

OPERATING INSTRUCTIONS

MODEL 45D VALVE TESTER

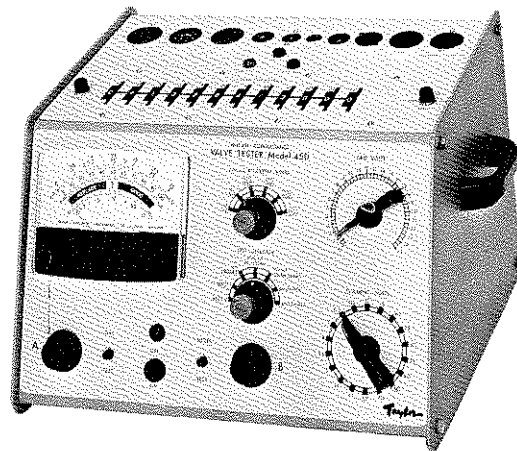

TAYLOR VALVE TESTER MODEL 45D

SECTION 1

GENERAL INFORMATION

1. INTRODUCTION

The Taylor Valve Tester Model 45D is a general purpose instrument, capable of testing practically every known type of electronic valve except for the larger transmitting types. Any normal fault can be rapidly detected and the general condition of a valve precisely measured by the mutual conductance test. The instrument is self-contained, ac operated and the number of controls have been reduced to a minimum for simplicity of operation. In addition to this Instruction Manual, the instrument is supplied complete with a Taylor Valve Data Manual giving test data for approximately 7,000 valves. In addition, valves for which information is not given in the Taylor Valve Data Manual may be tested using manufacturer's data. Cathode ray tubes can also be tested using a suitable adaptor which is available as an optional accessory (See Section 4).

2. CONNECTION TO SUPPLY

A 3-pin plug should be fitted to suit the socket available, the connections being made in the following manner:—

Red or brown—Line Black or blue—Neutral Green or green and yellow—Earth.

If a 2-pin plug is used, the green (or green and yellow) wire should preferably be connected to a separate earth. The instrument is designed to operate from supplies of 100-125 or 200-250V, 40-60 Hz. The voltage selector panel will be found at the rear of the instrument, and the insulated link should be inserted into the socket corresponding to the actual voltage of the supply, which should be ascertained using an accurate ac voltmeter.

3. CONTROLS

All the controls necessary for carrying out the essential valve testing functions are mounted on the exterior of the instrument. Using these controls the following information may be obtained:—

- (a) A direct measurement of mutual conductance in milliamperes/volt up to a maximum of 30mA/V over a full range of applied anode, screen and grid volts.
- (b) A direct indication of cathode to heater insulation.
- (c) An indication of positive or negative grid current.
- (d) A direct indication of anode current.
- (e) The efficiency of rectifiers and diodes on a good/replace scale.
- (f) An indication of filament continuity.

The functions of each control are detailed below:—

Grid Volts Control

This is a continuously variable control calibrated 0 to 25, which enables the initial negative grid bias for the valve under test, to be set at any value between 0 and minus 25 volts.

Filament Volts Switch

Heater voltages are selected using this 18-way switch which may be set to a suitable value between 1·1V and 117V.

Anode and Screen Voltage Switch

This is a dual concentric switch which enables the requisite electrode voltages to be applied to the screen and anode of the valve under test. The anode or screen voltages may be varied independently, the red knob controlling the anode voltages and the black knob the screen voltages.

Test Selector

This is also a dual concentric switch which determines the type of test to be undertaken on the valve. All the necessary internal circuit connections are made automatically to satisfy the test conditions required, whilst internal test circuits unnecessary to the particular test in hand are removed from the valve. The red knob selects either the appropriate range of anode current for the valve under test, i.e., 10mA or 100mA, or a 'gm' position which is used for all other tests. (These functions are indicated in red). The black knob selects the loading for the rectifiers and diodes in addition to the two ranges of mutual conductance and is also used for filament continuity and cathode leakage measurements (These functions are indicated in black).

Controls 'A' and 'B'

These controls are used during mutual conductance and gas tests only. Control 'A' is used for setting the meter pointer to a calibration mark on the scaleplate and control 'B' is a backing-off potentiometer which is used to return the pointer to the zero position.

Push Buttons 'Gas Test' and 'Meter Test'

These push buttons are used during mutual conductance, anode current and gas tests. The push-button GAS TEST is depressed to check for excessive grid current and the push button METER TEST is depressed to indicate mA/V on the mutual conductance ranges and the anode current on the 0 to 100 mA scale.

Mains ON/OFF Switch

When set to the ON position the mains supply is applied to the instrument and the lamp above the ON/OFF switch is illuminated.

Selector Switch

The Selector switch, comprising a row of twelve edge control switches numbered 1 to 12 and marked 'Valve Pin Numbers', enables any one of the standard twelve pin numbers to be connected to any one of the electrode test circuits in the instrument, thus enabling any electrode combination to be set up for all valveholders.

The numbering immediately behind the rollers corresponds to the valve pins in the order of their standard pin numbering. This corresponds to the Selector switch numbers in the Taylor Valve Data Manual.

4. METER SCALES

The outer scale is calibrated directly in mA/V, the two sets of figures referring to the two ranges available on the TEST SELECTOR i.e., 0 to 3 and 0 to 15mA/V. The scale calibrated 0 to 100mA is for use during anode current measurement, full scale deflection corresponding to either 10mA or 100mA according to the setting of the TEST SELECTOR. The Replace—?—Good scale is used for rectifier, diode and filament continuity tests only. The remaining scale is calibrated in megohms and is used on cathode leakage tests only.

SECTION 6

CIRCUIT COMPONENT LIST

Cct Ref.	Value	Part No.	Cct Ref.	Value	Part No.
R.1	1kΩ ± 5% 6W	110210	T.1	Mains Transformer	300035-1
R.2	2kΩ ± 5% 6W	120215	T.2	Filament Transformer	300034-1
R.3	127kΩ ± 5% 0.5W	113406	M.1	250μA f.s.d.	831586
R.4	75kΩ ± 5% 0.5W	175307	ILP.1	Neon	661087
R.5	10kΩ ± 5% 0.5W	110314		Top cap lead assembly	831150
R.6	270Ω ± 5% 0.5W	127406		Red, moulded knob	661091-2
RV.7	2kΩ linear—B control	710099-2		Black " " with white spot.	661089-1
R.8	2.2kΩ ± 5% 1W	122204		Black moulded knob	661090-1
R.9	270kΩ ± 5% 0.5W	127402		Black pointer knob	661088
RV.10	2kΩ linear ± 1%	710100-2		P.V.C. feet	660018
R.11	24Ω ± 5% 0.5W	124001		Mains adjust panel	740252-1
R.12	11Ω ± 5% 0.5W	111001		Fuse holder	740284
RV.13	2kΩ Graded	710098-2		4 mm red socket	720058
R.14	2kΩ ± 5% 1W	120205		4 mm black socket	720059
R.15	550Ω ± 5% 6W	155103		4 mm green socket	720060
R.16	110Ω ± 5% 6W	111107		B14E valve holder	740259
R.17	3.774Ω ± 1% Wirewound	831134		B8G " "	740033
R.18	40Ω ± 1% Wirewound	831135		A08 " "	740017
RV.19	500Ω Pre-set	740262		B9A " "	740253
R.20	560Ω ± 5% 0.5W	156102		B7G " "	740254
C.1	0.01μF	200003		B10B " "	740256
C.2	0.01μF	200003		B8A " "	740049
C.3	0.1μF	210053		B9D " "	740257
FS.1	150mA	740264		Compactron valve holder	740258
FS.2	1A for 200 to 240V 2.5A for 100 to 125V	740137 740265		N.V. valve holder	831153
SA	Anode and Screen Volts	700125-1		Edge control switch 0-6	700124
SB	Filament Volts	700126-1		Case handle	660219
SC	Test Selector	700127		Front escutcheon	501276-1
SD	Mains ON/OFF	700128		Top escutcheon	501275-1
PB.2	Gas Test	661086		Case body	501271
PB.1	Meter Test	661085		Case back	501272-1
MR.1	P8/1B	740250		Case end plate L/H	501268-1
MR.2	P8/1V	740251		Case end plate R/H	501269-1
				Edge switch assembly (12 switch mounted)	831179
				Printed circuit panel assembly complete	831587

18. GAS TEST

After checking Mutual Conductance or Anode Current (as described in paras 16 and 17) the valve under test can be checked for excessive grid current as follows:—

Leaving the edge control Roller switches, grid volts, anode and screen volts controls in the same position, rotate control B fully clockwise. Control A should also be rotated clockwise up to a point where the meter pointer reaches half full scale deflection, then depress GAS TEST button. If the meter pointer goes beyond full scale or below zero the valve has excessive grid current. The pointer deflects to the right if there is excessive positive grid current and to the left for excessive negative grid current or grid emission.

19. RECTIFIERS

Rect. 1. First ensure that the instrument is switched off, then set the edge control Roller switches and filament voltage control to the settings specified in the Taylor Valve Data Manual and the anode volts switch to 100. Rotate TEST SELECTOR to 'Fil-Cont'. Insert rectifier valve into the appropriate valvholder and switch on instrument. If filament continuity is 'Good' rotate TEST SELECTOR to 'Rect. 1'. Allow valve to conduct and read the condition on coloured meter scale. Repeat for further anodes if required.

Rect. 2. This is a similar test and should be applied to high current rectifiers which draw a current greater than 50mA each section.

Cold Cathode Rectifiers

When testing cold cathode rectifiers, e.g., OZ4, the anode and screen voltage should be set to 250 and 200 volts respectively, which will cause the OZ4 to strike. The anode and screen voltage should both be reduced to 100V when an indication of the emission will be given on the Good/Replace scale. Failure to strike or the loss of emission before the 100V position is reached, indicates a faulty valve.

WARNING. CARE SHOULD BE TAKEN WHEN TESTING RECTIFIERS, (OTHER THAN COLD CATHODE TYPES) THAT THE ANODE VOLT SWITCH IS SET TO 100 AS FAILURE TO DO SO WILL DAMAGE SMALLER TYPES OF RECTIFIERS.

20. DIODES

Follow the same procedure as previously described for rectifier testing, but the TEST SELECTOR switch should be set to the 'Diode' position.

5. VALVEHOLDERS

The valvholder panel which is mounted on the top of the instrument comprises ten valvholders of the following types:—Compactron (A12), B9D, B8A, B10B, Nuvistor (NV) B7G, B9A, International Octal (AO8), B8G. The tenth valvholder, a B14E base is for use with a range of adaptors enabling either cathode ray tubes, obsolete valves or any new types of valve which may be introduced, to be tested. The standard pin connections are given in the Valve Data Manual.

If the valve base required does not appear on the Valve Holder Panel the following adaptors are available for use in conjunction with the B14E base:—

ADAPTOR TYPE NO.	VALVE BASE
45D/UX4	UX4
45D/UX5	UX5
45D/UX6	UX6
45D/UX7	UX7
45D/MO8	MO8
45D/B5	B5
45D/B7	B7

The red, black and green sockets mounted adjacent to the valvholders enable top cap connections to be made to anode, cathode or grid as required, a clip lead being supplied with the instrument for this purpose.

6. FUSES

Two fuses are incorporated in the instrument, these are located on the top panel of the instrument adjacent to the edge control Roller switches. The fuse on the right-hand side of the Roller switches marked 'Anode fuse 150mA' is incorporated in the anode circuit of the valve and is designed to protect the instrument should current exceed 150mA. It is advisable to have spare fuses available for replacement purposes and the type required is a Belling Lee type L562, Taylor Part No. 740264.

The other fuse on the left-hand side of the roller switches is connected in the primary of the mains transformer and acts as an extra safety device should any serious fault develop within the instrument or to the valve under test. Should this fuse rupture the indicating lamp will fail to illuminate.

NOTE: If the instrument is to be used continuously on 110 volts it is advisable to replace the mains fuse by one having a rating of 2A.

SECTION 2

PRINCIPLES OF OPERATION

7. RECTIFIERS

The complete circuit diagram of the instrument is shown in Fig. 8 at the end of this Instruction Manual, but in order to assist the user in understanding the various functions of instrument, the main circuit has been broken down into a number of simplified diagrams and these are given in the following paragraphs together with a brief note outlining the general principles of operation.

Rect. 1. (See Fig. 1). In this test 100 volts ac is applied to the anode circuit via a load resistor (R1), the value of which is selected such that the average good rectifier will pass a current sufficient to give a meter indication in the 'Good' Sector. The meter is shunted to approximately 22mA full scale deflection. Screen voltage is not applied but grid volts are available for tests on grid controlled rectifiers.

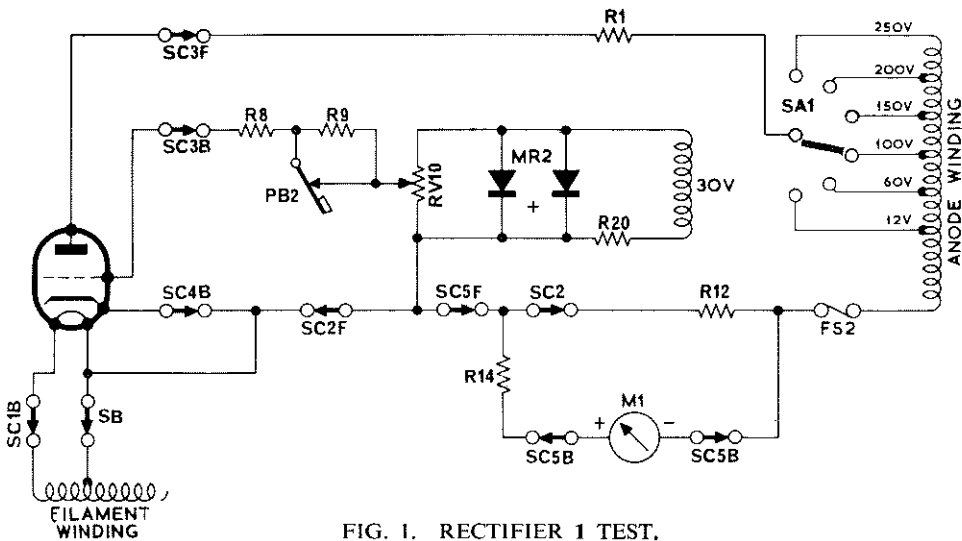

FIG. 1. RECTIFIER 1 TEST.

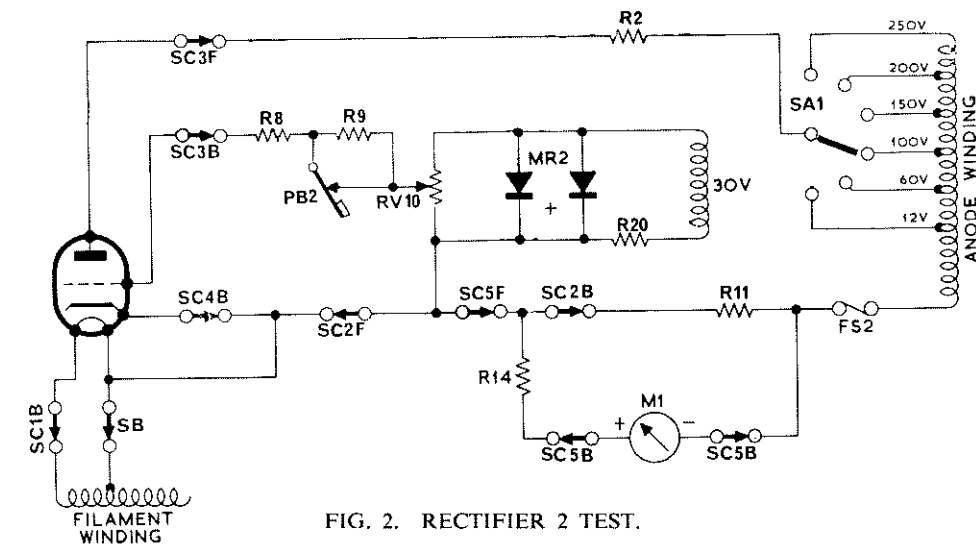

FIG. 2. RECTIFIER 2 TEST.

Rect. 2. (See Fig. 2). Conditions are the same during this test as for Rect. 1 with the exception that an increased current is drawn through the rectifier by reducing the value of the load resistor R2 and shunting the meter to a higher full scale value.

Mercury vapour and gas-filled triodes (thyatron) are tested with the voltage settings given but on 'Rectifier 1' position. The grid volts should be reduced slowly from 25 and at some lower value the valve should start to conduct, which is indicated by deflection of the meter pointer. The value of grid voltage should be noted and divided into the anode voltage of the valve under test, the resultant being the control ratio of the valve, i.e., control ratio equals anode volts divided by grid volts.

NOTE: In the following operating instructions the setting of switches not mentioned is immaterial.

14. FILAMENT CONTINUITY

Set the TEST SELECTOR to 'Fil-Cont' using the black knob and to 'gm' using the red knob. If the filament is intact the pointer should reach a point approximately halfway across the 'Good' sector of the scale.

15. CATHODE LEAKAGE

Set edge control switches and filament volts as specified in the Taylor Valve Data Manual. Set the TEST SELECTOR to 'Cathode Leakage' using the black knob. The meter pointer will kick to the right, then fall back to some steady reading.

It is not possible to lay down a hard and fast rule as to the minimum acceptable resistance as so much depends on the type of valve and the circuit in which it is used. As a general guide, however, at least 2 megohms should normally be obtained and a reading of 1 megohm or less will usually indicate a faulty valve. Whether it need be rejected on this account depends entirely on the circuit in which it is used.

16. MUTUAL CONDUCTANCE

Before checking Mutual Conductance, Filament Continuity and Cathode Insulation should be checked as previously described. If these are satisfactory, using the black knob set the TEST SELECTOR to '3mA/V' or '15mA/V', the position selected being dependent upon figures given for Mutual Conductance in the Valve Data Manual. Rotate control A clockwise until the pointer reaches the X1 mark. Rotate control B clockwise until pointer returns to zero. Depress METER TEST button and read mA/V directly on the outer scale.

NOTE: (a) With a few valve types having low emission it may not be possible to reach the X1 mark even with control A fully clockwise. In these cases use the X2 mark and multiply the mA/V reading by 2. This procedure should also be followed if the valve has a Mutual Conductance greater than 15.

NOTE: (b) Having completed testing for Mutual Conductance on one section of a multiple electrode assembly valve it is imperative that the TEST SELECTOR is returned to the 'Fil-Cont' position before altering the edgewise Roller Selector switches. Failure to carry out this operation may result in damage to the valve under test or to the instrument.

NOTE: (c) If the meter pointer is seen to be vibrating this is due to unrectified ac across the meter circuit and is probably caused by an internal short in the valve under test. The instrument should be switched off immediately to avoid damage to the meter.

17. ANODE CURRENT MEASUREMENT

When Mutual Conductance readings have been obtained the approximate anode current of the valve under test may be ascertained by rotating the red knob of the TEST SELECTOR to '100mA' or '10mA' dependent upon the value given in the I_a column of the Taylor Valve Data Manual. The METER TEST button should then be depressed and the anode current will be indicated on the scale calibrated 0 to 100mA. If the TEST SELECTOR is set at '100mA' the value may be read directly, but if the TEST SELECTOR is set at '10mA' the reading should be divided by 10.

TABLE 1

Test Selector Position	Sequence of Tests							Remarks
	Rect	Diodes	Triode or Screen Grid	Gas Rectifier	Gas Triode & Tetrode	Tuning Indicator	CRT†	
RECTIFIER 2	4*	—	—			—		
RECTIFIER 1	3	—	—	3	3	—		
DIODES	—	3	—	—	—	—	3	
FILAMENT CONTINUITY	1	1	1	1	1	1	1	UNLESS COLD CATHODE
CATHODE LEAKAGE	2	2	2	2	2	2	2	UNLESS DIRECTLY HEATED
MUTUAL CONDUCTANCE	—	—	3	—	—	3		
GAS TEST	—	—	4	—	—	4		
ANODE CURRENT		—	5					

* Note. Only if valve under test is high current rectifier.

† See Section 4.

The full sequence of tests is suitable for testing valves of unknown condition, but if, for example, a valve working in an amplifier, is suspected of low gain it may be tested for mutual conductance only.

Multiple valves, such as double triodes, are treated as several separate valves, the proper test conditions for each section being listed in the Taylor Valve Data Manual.

Tuning indicators ('magic eye' valves) are also tested in sections, first normal tests on the amplifier section, then a test on the shadow section. For the latter, moving the Anode and Screen volts switch from the potentials given for the 'Shadow' test in the Valve Data Manual, to those indicated in the lines of data marked 'Test' should cause a distinct change in the angle of the shadow.

In the case of gas-filled valves, particularly mercury vapour types, it is important to wait for one minute on the 'Cathode Leakage' position before switching to 'Rect. 1' or to 'Mutual Conductance'. This is to ensure that the cathode is at operating temperature before anode voltage is applied.

8. DIODES (See Fig. 3).

This test is similar to that for rectifiers except that the test voltage is reduced to 60 and the value of the load resistor R4 is increased. The shunt is removed from the meter so that its full sensitivity of 250µA is available. During this test neither screen nor grid voltages are required.

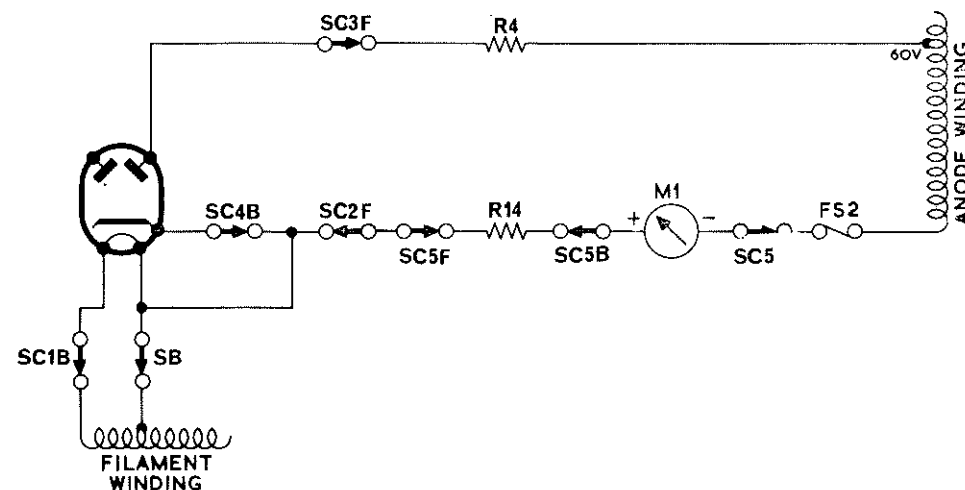

FIG. 3. DIODES.

9. FILAMENT CONTINUITY (See Fig. 4)

Approximately 0.5 volt rectified dc is applied to the filament through the meter and a limiting resistor (R14). The maximum current is approximately 200µA which can be considered safe for all valves.

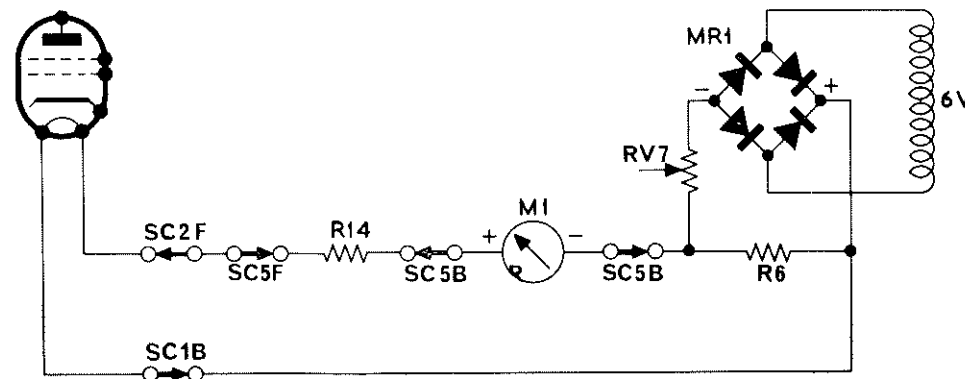

FIG. 4. FILAMENT CONTINUITY.

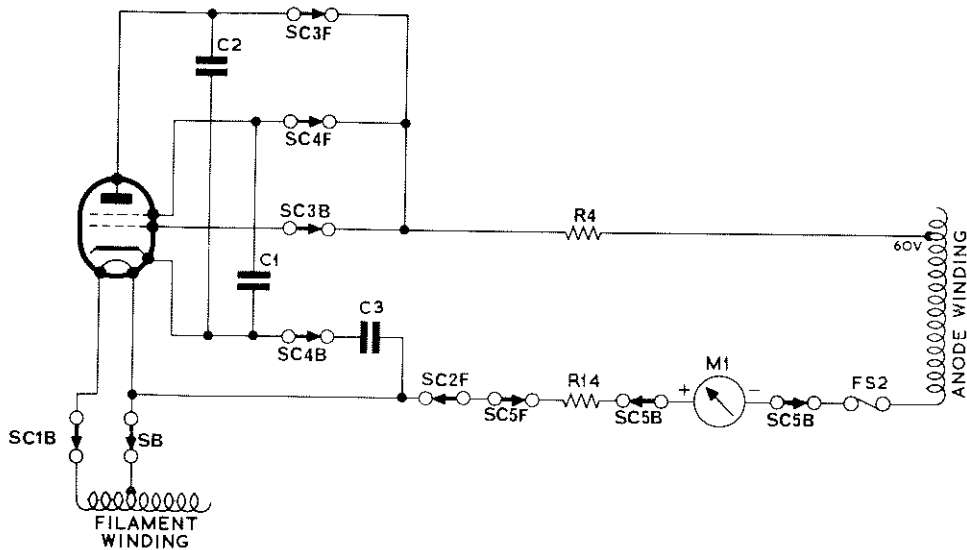

FIG. 5. CATHODE LEAKAGE.

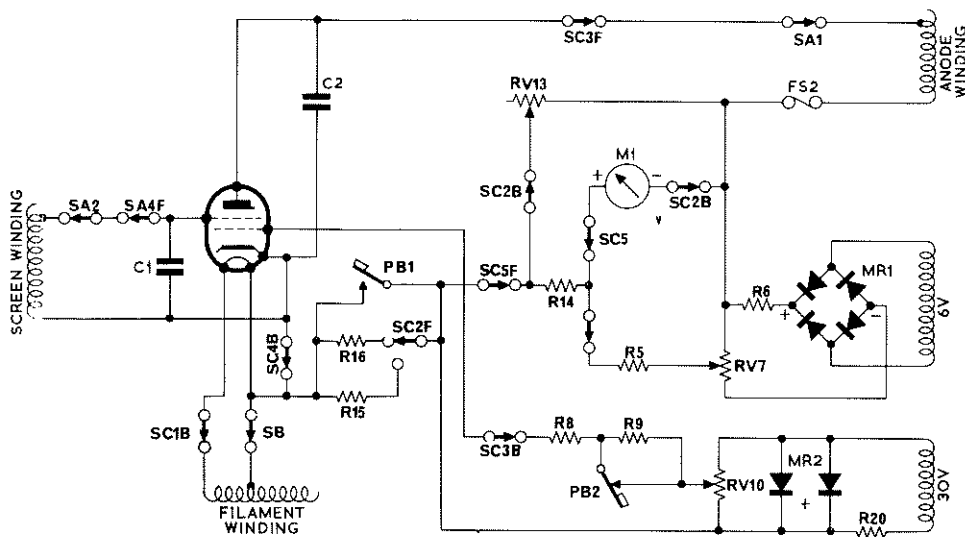

FIG. 6. MUTUAL CONDUCTANCE.

SECTION 4

CATHODE RAY TUBE ADAPTOR MODEL 456

This adaptor which is used in conjunction with the Valve Tester Model 45D, is fitted with valveholders which enable cathode ray tubes with the following valve bases to be tested. B8H, B12A and 14AU. Test data for the majority of cathode ray tubes is given in the Taylor Valve Data Manual, including information on the testing of colour television tubes, for which a separate line of test data is given for each gun assembly. The top line is for the green gun, the centre line is for the red gun and the bottom line is for the blue gun.

OPERATION

The adaptor lead should be plugged into the B14E valve base on the Valve Holder panel and the adaptor should be fitted to the base of the tube to be tested. (Care should be taken to protect the cathode ray tube from damage due to the weight of the adaptor).

The Valve Tester controls should be set as follows:—
FILAMENT VOLTS—as given in the Taylor Valve Data Manual or manufacturer's data.
TEST SELECTOR—to the 'Diode' position.

Check the manufacturer's data for beam current. (See NOTE). The ON/OFF switch may now be set to the 'ON' position and the tube emission will be indicated on the coloured scale, either 'GOOD' or 'REPLACE' (as when testing diodes).

NOTE: The full scale reading on the diode position is $250\mu\text{A}$. Thus a correct indication of emission cannot be obtained for the small percentage of tubes having only $50\mu\text{A}$ beam current, as a 'REPLACE' indication would be obtained, when in fact, the tube may be serviceable. It is therefore always advisable to check manufacturer's data for the beam current of the respective tube.

Filament Continuity and Cathode Leakage tests may also be carried out as for normal valves.

SECTION 5

TEST PROCEDURE

13. APPLICATION OF TESTS

The test procedure is described in the following paragraphs. Which tests should be applied, and the order in which they should be carried out, depends on the type of valve and the conditions under which it is operating in the equipment.

Table 1 lists the recommended sequence of tests on valves of seven general categories, i.e., rectifier, diode, triode, etc. The numerals indicate the recommended order of testing, thus, for a triode, the first test would be filament continuity, the second cathode leakage, the third mutual conductance, the fourth gas test and the fifth anode current. Similarly the recommended sequence of tests for the remaining six types of valve may be ascertained.

VALVE TYPE

SET-UP NUMBER

BASE DIAGRAM

10. CATHODE LEAKAGE (See Fig. 5)

For this test all the electrodes except cathode and heater are strapped together and a capacitor (C3) is connected between heater and cathode. An ac voltage is applied causing the valve to act as a rectifier such that a potential of approximately 50 volts dc appears between heater and cathode. Leakage current will be indicated directly in megohms on the appropriate meter scale.

11. MUTUAL CONDUCTANCE (See Fig. 6)

For this test the anode, screen and grid voltages may be selected as required using the appropriate anode, screen and grid controls. These are ac potentials with the exception of the grid voltage which is prevented from going positive by a stopper rectifier MR2. The phasing of the transformer windings is arranged such that the anode and screen voltages are in phase whilst the grid voltage is out of phase. When the anode and screen voltages are positive and the grid voltage is negative, the valve under test conducts and current will flow through the meter. When the anode and screen voltages are negative the grid voltage is zero, and the valve under test ceases to conduct. Thus it can be seen that the valve under test acts as a half-wave rectifier.

During the Mutual Conductance Test, voltages are applied as follows:—

- (a) Screen voltage between cathode and screen grid.
- (b) Grid voltage between control grid and the lower end of a cathode resistor (R15 or R16).
- (c) Anode voltage between the anode and the lower end of the cathode resistor R15 or R16. therefore the cathode resistor only carries anode current.

The meter reads anode current and is initially shunted to zero by means of RV13. As soon as the valve warms up pulsating anode current flows and the meter reads when control A is rotated clockwise until the pointer reaches the X1 mark which is at 60% of full scale deflection. Control A is a potentiometer RV13 which functions as an adjustable meter shunt. When it is fully anti-clockwise the meter is short-circuited and reads zero.

Control B (RV7) should now be operated until sufficient backing-off voltage is applied to return the meter to zero. The voltage applied to control B is obtained from a separate winding on the transformer and is rectified by a bridge rectifier circuit.

Operating the METER TEST button effectively alters the bias by shorting out the cathode resistor and causes an increase in anode current which is then read directly on the meter scale calibrated in mA/V.

The cathode resistor has a value of 555 ohms on the 3mA/V range and 111 ohms on the 5mA/V range.

The theory of operation is as follows:—

Suppose the meter is shunted so that it reads XmA full scale. Since the X1 mark is at 60% full scale, the anode current is $\frac{3X}{5000} A$. On the 3mA/V range the cathode resistor is 555 ohms there-

fore the cathode bias voltage is $\frac{555 \times 3X}{5000}$ which equals $\frac{X}{3}$ volts. Suppose the valve on test has a mu-

tual conductance of 3mA/V under the specified test condition, then its anode current increase when the cathode resistor is shorted, is $3 \times \frac{X}{3}$ which equals XmA. The meter therefore reads full scale cor-

responding to 3mA/V. Similarly for lower values of mutual conductance on this range.

Operation on the 15mA/V range is the same except that the value of the cathode resistor is 111 ohms and the meter is read on the 0 to 15mA/V scale.

Osram U50 Full Wave Rectifier Directly heated octal base

0	2	0	6	0	0	0	3	0	0	0	0
—	H	—	—	A	—	—	H+	—	—	—	—
0	2	0	0	0	6	0	3	0	0	0	0
—	H	—	—	—	A	—	H+	—	—	—	—

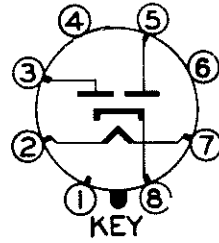

Mullard EL84 High Slope Pentode

0	4	1	2	3	0	6	0	5	0	0	0
—	G	C	H	—	H+	—	A	—	S	—	—

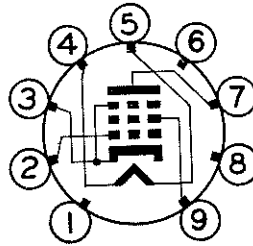

Mullard ECC81 Miniature High Slope Double Triode (Heaters wired in parallel)

0	4	1	2	2	6	4	1	3	0	0	0
—	G	C	H	—	H	—	A	G	C	H+	—
6	4	1	2	2	0	4	1	3	0	0	0
A	G	C	H	—	H	—	G	C	H+	—	—

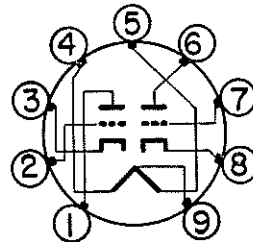

Brimar 6K8 Triode Hexode Frequency Changer

0	2	0	0	4	6	3	1	0	0	0	0
—	H	—	—	G	A	H	—	C	—	—	—
0	2	6	5	4	0	3	1	0	0	0	0
—	H	—	A	S	G	—	H	—	C	—	—

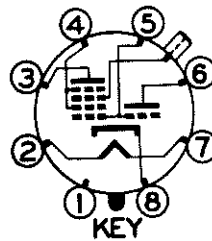

ANODE CURRENT

Anode current measurements are made with the circuit as shown in Fig. 7. This is a similar circuit to that used for mutual conductance measurements, but the meter is shunted to 10mA f.s.d. by means of R18 or 100mA by R17, the resistor being selected by SC5(F).

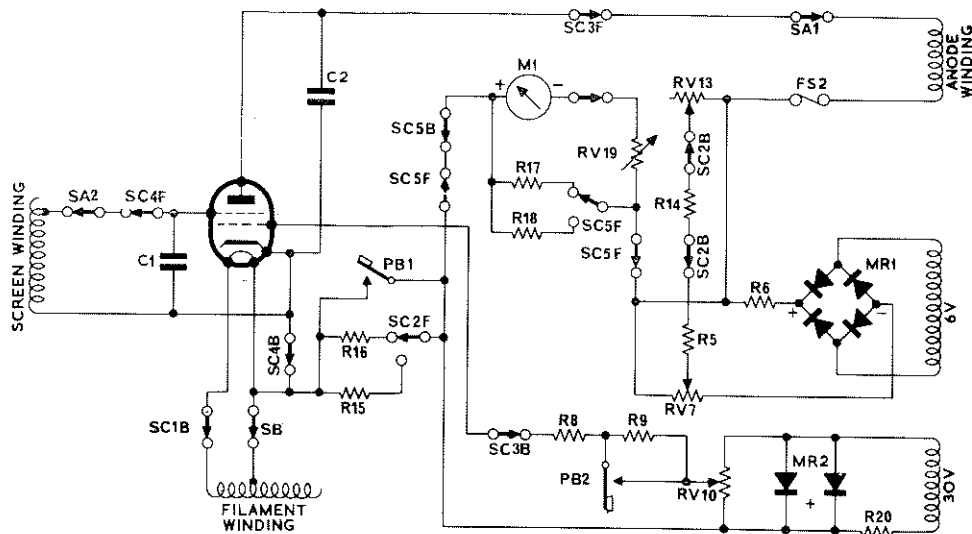

FIG. 7. ANODE CURRENT MEASUREMENT.

12. GAS BUTTON

When control 'A' is fully clockwise, the meter is shunted to approximately 500 μ A full scale.

The value of the grid resistor is 270k ohms, thus with a low slope valve the usual grid current of 2 μ A produces a grid voltage change of 0.54 volts which is likely to cause an I_a change of approximately 0.54mA. With a high slope valve the grid current is usually limited to 0.7 μ A which corresponds to a grid voltage change of 0.19 volts and produces a similar change in anode current.

SECTION 3

ROLLER SELECTOR SWITCH

The valve holders are all wired with their corresponding pins, according to the standard pin numbering, in parallel, i.e., all pins numbered 'one' are wired together, all pins numbered 'two' are wired together and so on. This wiring combination enables any one of the twelve standard pin numbers to be connected to any one of the electrode test circuits in the Valve Tester, thus enabling any electrode combination to be set up for any normal valve holder.

It will be seen that the Roller Selector switch comprises twelve thumb control rollers, numbered from left to right 1 to 12. This numbering appears immediately behind the roller and corresponds to the valve pins in the order of their standard pin numbering. Thus valves, with any number of base connections up to twelve, can be accommodated.

Rotation of the rollers by the finger rim provided, will reveal that each roller can be set in any one of seven positions, the setting in question being indicated in the aperture. The seven positions on the roller are marked as under:—

0	1	2	3	4	5	6
—	C	H	H+	G	S	A

The standard procedure for setting up a valve ready for test is as follows:—

From some suitable source i.e., Taylor Valve Data Manual, or manufacturer's data, determine the base pin connections for the valve, in order of their standard pin numbering. Rotate the rollers until the set-up number appears in the aperture reading from left to right in order of the standard pin numbering. In the case of valves having less than twelve pins the rollers on the right are not used and should be set at zero.

When the valve is inserted in the appropriate valve holder, use the universal top cap lead to connect any top cap or side connection on the valve to its appropriately marked socket. Note that the local valve holder having only eight normal pins has its centre lug connected to the ninth roller (corresponding to pin No. 9) to accommodate valves which have a cathode connection made to this lug.

In the case of Nuvistor valves a connection is sometimes made to the lug at the base of the valve and for this reason the lug is connected to roller number one.

The following examples indicate the procedure to be adopted when converting the connections given by the manufacturer to the Roller Selector switch numbers on the Valve Tester.

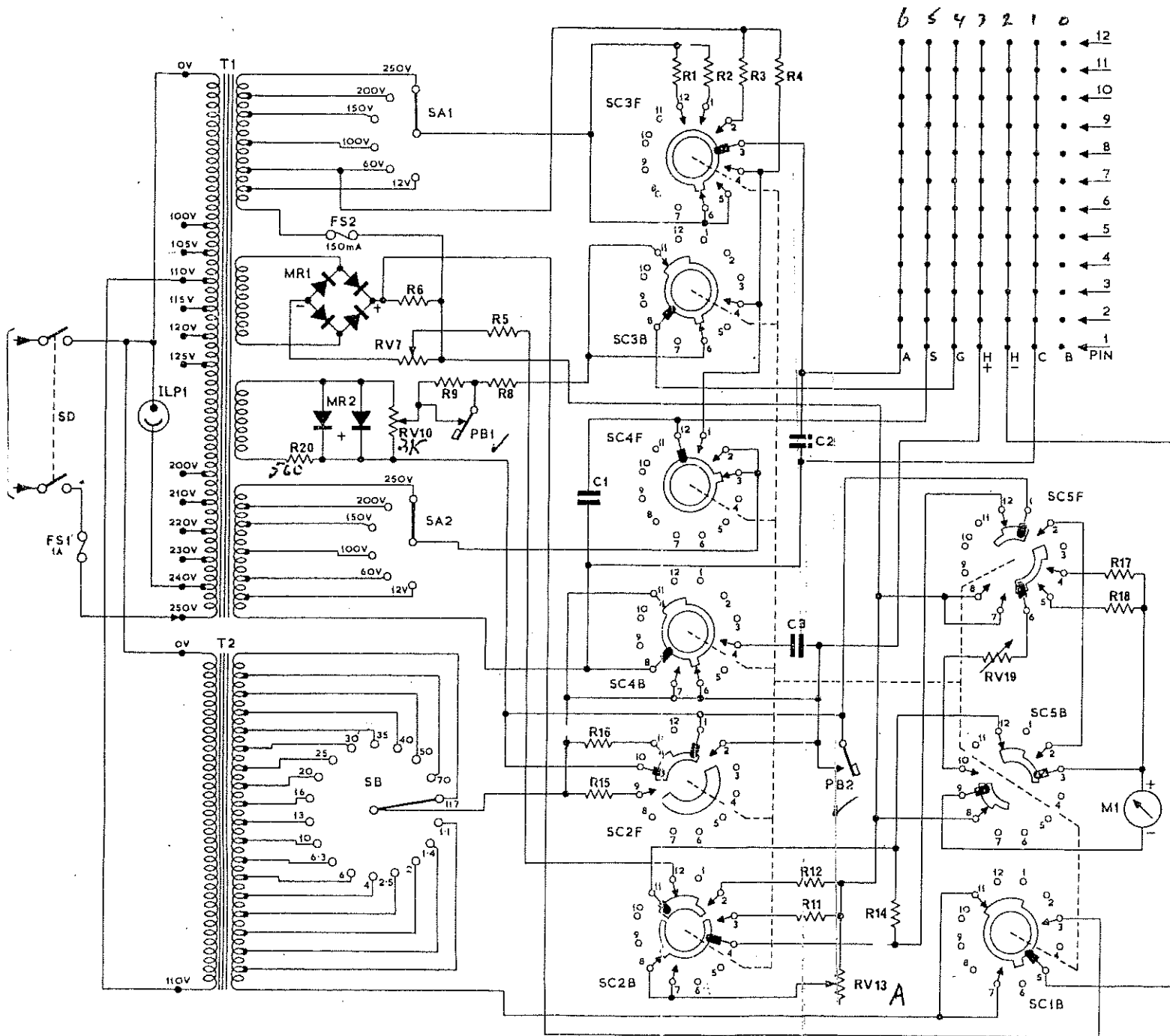

6 5 4 3 2 1 0

CIRCUIT CONNECTIONS OF VALVE HOLDERS (BOTTOM VIEW)

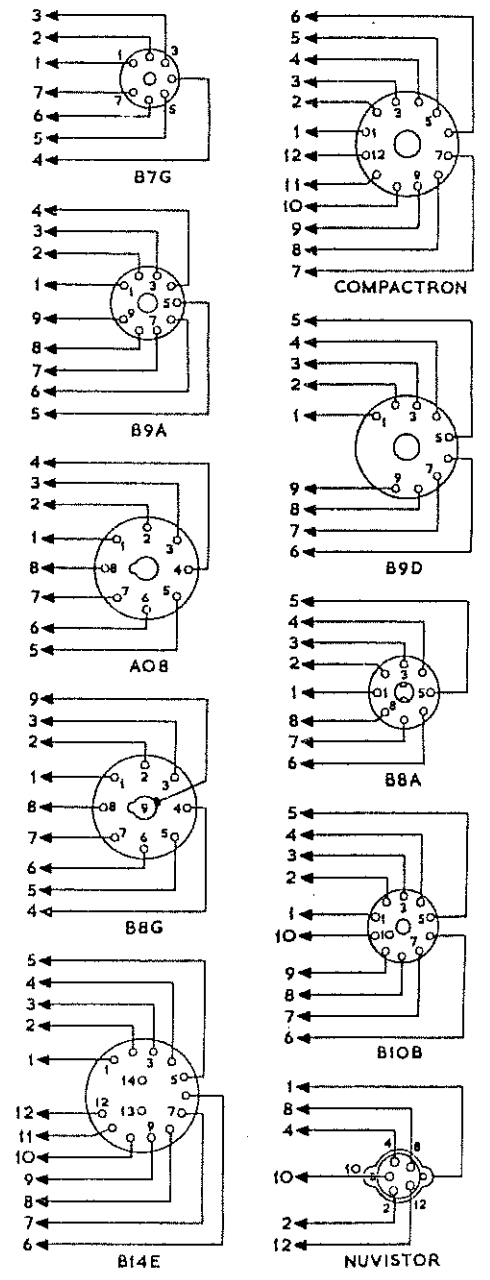

SECTION 6

CIRCUIT COMPONENT LIST

Cct Ref.	Value	Part No.	Description	QTY
R.1	1K Ω \pm 5% 6W	110210	T.1 Mains Transformer	300035-1
R.2	2K Ω \pm 5% 6W	120215	T.2 Filament Transformer	300034-1
R.3	127K Ω \pm 5% 0.5W	113406	M.1 250 μ A f.s.d.	831192
R.4	75K Ω \pm 5% 0.5W	175307	ILP.1 Neon	661087
R.5	10K Ω \pm 5% 0.5W	110314	Top cap lead assembly	831150
R.6	270 Ω \pm 5% 0.5W	127406	Red, moulded knob	661124-1
RV.7	2K Ω linear—B control	710099-1	Black " " with white spot.	661089-1
R.8	2.2K Ω \pm 5% 1W	122204	Black moulded knob	661090-1
R.9	270K Ω \pm 5% 0.5W	127402	Black pointer knob	661088
RV.10	2K Ω linear \pm 1%	710100-1	P.V.C. Feet	660018
R.11	24K Ω \pm 5% 0.5W	124001	Mains adjust panel	740252-1
R.12	11 Ω \pm 5% 0.5W	111001	Fuse holder	740136
RV.13	2K Ω Graded	710098-1	4 mm red socket	720058
R.14	2K Ω \pm 5% 1W	120205	4 mm black socket	720059
R.15	550 Ω \pm 5% 6W	155103	4 mm green socket	720060
R.16	110 Ω \pm 5% 6W	111107	B14E valve holder	740259
R.17	3.774K Ω \pm 1% Wirewound	831134	B8G " "	740033
R.18	40 Ω \pm 1% Wirewound	831135	A08 " "	740017
RV.19	500 Ω Pre-set	740262	B9A " "	740253
R.20	560 Ω \pm 5% 0.5W	156102	B7G " "	740254
C.1	0.01 μ F	200003	B10B " "	740256
C.2	0.01 μ F	200003	B8A " "	740049
C.3	0.1 μ F	210053	B9D " "	740257
FS.1	150mA	740264	Compactron valve holder	740258
FS.2	1A for 200 to 240V 2.5A for 100 to 125V	740137 740265	N.V. valve holder Edge control switch 0-6	831153 700124
SA	Anode and Screen Volts	700125-1	Case handle	660219
SB	Filament Volts	700126-1	Front escutcheon	501276-1
SC	Test Selector	700127	Top escutcheon	501275-1
SD	Mains ON/OFF	700128	Case body	501271
PB.1	Gas Test	661086	Case back	501272-1
PB.2	Meter Test	661085	Case end plate L/H	501268-1
MR.1	P8/B	740250	Case end plate R/H	501269-1
MR.2	P8/IV	740251	Edge switch assembly (12 switch mounted)	831179
			Printed circuit panel assembly complete	831176



**TAYLOR ELECTRICAL
INSTRUMENTS LIMITED**

Archcliffe Road, Dover, Kent, England
Telephone: Dover 2634 Telex 96283



Part No. 93067

6170-306

Printed in England

www.everything4lessstore.com