



product modification

050-2240-03

M62235. M67697
M68204. M68308

Q935. Q946. Q947 OR Q9070 REPLACEMENT

For TEKTRONIX® 2236 Oscilloscopes:

Serial Numbers B010100 - B019719

This kit provides parts and instructions to replace Q935, Q946, Q947 and Q9070. Because failure of any one of these components may cause excess stress to the others, replacement of all components is recommended.

The new silicon control rectifier, pn 151-0565-01, used to replace Q935 has improved current characteristics. To prevent interference between the new SCR and the electronics module of the fan assembly, the SCR was laid down on the circuit board which required several components to be relocated.

The new field effect transistor, pn 151-1245-00, used to replace Q9070 has a higher voltage rating and the new inverter transistors, pn 151-0852-00, used to replace Q946 and Q947 have improved saturation characteristics. Use of the new FET requires changing the value of R908.

This replacement kit also incorporates the following reliability improvements.

1. The circuit location for VR901 and R900 are switched to prevent excess stress to VR901.
2. The values of R945 and R949 are changed to ensure the power supply shuts down if Q939, the inverter transistors, or the +8.6V, -8.6V or +5V supplies are shorted.
3. The value of R912 is changed and a diode-resistor network is added between the emitters of Q946/Q947 and the gate of Q935 to ensure power supply shutdown if an overvoltage occurs.

NOTE

Parts Replacement Kit, pn 050-2242-XX, is available to replace Q935, Q946, Q947, or Q9070 in 2236 oscilloscopes with serial numbers between B019720 and B028884, inclusive. If the serial number of the 2236 is greater than B028884, or if this kit or 050-2242-03 has been installed, disregard the instructions and use the part numbers listed in the parts list of this kit as direct replacements for the respective circuit numbers.

Copyright © 1989
Tektronix, Inc.
All Rights Reserved

3-22-89

Supersedes: 050-2240-02

page 1

CAUTION

STATIC SENSITIVE DEVICES

Static discharge can damage any semiconductor component in this instrument. Static voltages of 1kV to 30kV are common in unprotected environments.

TO AVOID DAMAGE, OBSERVE THE FOLLOWING:

1. Minimize handling of static-sensitive components.
2. Transport and store static-sensitive components or assemblies in their original containers, on a metal rail, or on conductive foam. Label any package that contains static-sensitive assemblies or components.
3. Discharge the static voltage from your body by wearing a wrist-strap while handling these components. Servicing static-sensitive assemblies or components should be performed only at a static-free work station by qualified service personnel.
4. Nothing capable of generating or holding a static charge should be allowed on the work station surface.
5. Keep the component leads shorted together whenever possible.
6. Pick up components by the body, never by the leads.
7. Do not slide the components over any surface.
8. Avoid handling components in areas that have a floor or work-surface covering capable of retaining a static-charge.
9. Use a soldering iron that is connected to earth ground.
10. Use only approved, anti-static type, desoldering tools.

KIT PARTS LIST:

Ckt. Number	Quantity	Part Number	Description
A1CR948/R948	1 ea	119-3511-00	Diode-resistor network
A1W934	1 ea	131-0566-00	Bus, conductor: Dummy resistor
A1Q935	1 ea	151-0565-01	Thyristor, SCR: 8A, 200V, sens gate, TO-220
A1Q946 A1Q947	2 ea	151-0852-00	Transistor: NPN, 50V, 150mA, 200mW, Inverter
A1Q9070	1 ea	151-1245-00	Transistor: MOSEFET, N-Channel, TO-220
A1VR935	1 ea	152-0255-00	Semiconductor device, di: Zener, 51V, 5%
A1C919	1 ea	281-0852-00	Capacitor, cer: 1800pF, 10%, 100V
A1R945	1 ea	301-0202-00	Resistor, fxd, film: 2k Ω , 5%, 0.5W
A6R900	1 ea	301-0474-00	Resistor, fxd, film: 470k Ω , 5%, 0.5W
A6VR901	1 ea	307-0456-00	Resistor, volt sens: 250vac, 20W
A1R949	1 ea	308-0755-00	Resistor, fxd, ww: 0.75 Ω , 5%, 2W
A1R941	1 ea	315-0102-00	Resistor, fxd, film: 1k Ω , 5%, 0.25W
A1R919	1 ea	315-0103-00	Resistor, fxd, film: 10k Ω , 5%, 0.25W
A1R919	1 ea	315-0113-00	Resistor, fxd, film: 11k Ω , 5%, 0.25W
A1R935	1 ea	315-0121-00	Resistor, fxd, film: 120 Ω , 5%, 0.25W
A1R908	1 ea	315-0222-00	Resistor, fxd, film: 2.2k Ω , 5%, 0.25W
A1R919	1 ea	315-0912-00	Resistor, fxd, film: 9.1k Ω , 5%, 0.25W
A1R912	1 ea	321-0162-00	Resistor, fxd, film: 475 Ω , 1%, 0.125W
	1 ea	361-0385-00	Spacer, transistor
	1 ea	-----	Label: 050-kit

INSTALLATION INSTRUCTIONS:

WARNING

Dangerous shock hazards may be exposed when the instrument covers are removed. Before proceeding, ensure the power switch is in the off position. Then, disconnect the instrument from the power source. Disassembly should only be attempted by qualified service personnel.

- () 1. Remove the instrument wrap-around cabinet.
- () 2. Remove the plastic, lower electrical shield from the solder side of the Main circuit board.

- () 3. Lift the CTM circuit board up to the service position and secure the board latch into the chassis side rail.
- () 4. Remove the power supply electrical shield from the component side of the Main circuit board.
- () 5. Remove the fan motor and electronic module assembly from the scope.

Make the following changes on the A1 Main circuit board.

NOTE

New components have been provided in this kit to facilitate relocating the components in the following step. Three resistor values have been provided for R919 which is a selectable resistor. R919 in conjunction with C919 determine the frequency of the oscillator, U930. At some frequencies the power supply emits an audible noise which can be eliminated by selecting the value of R919.

- () 6. Relocate C919, R919 (10k Ω nominal value), R934*, R935**, R941 and VR935 from the component side of the Main circuit board to the solder side of the circuit board. Note which circuit board pads each component uses to facilitate installation of the components on the solder side of the circuit board.

* R934 is being replaced with a 0 Ω dummy resistor, W934.

** When relocating R935, only solder the lead nearest the front of the scope. Place the remaining lead into the circuit board hole but do not solder. The cathode lead of the diode-resistor network will be added to this location in a later step.

- () 7. Remove TP940, the 43V test point. In the future, use the tab of the new SCR as the 43V test point.
- () 8. Remove CR945. This diode is no longer required.
- () 9. Replace R945, a 6.2k Ω 0.5W resistor, with the 2k Ω resistor included in this kit.
- () 10. Replace R949, a 0.51 Ω 2W resistor, with the 0.75 Ω resistor included in this kit. When installing the new resistor, only solder the lead of the resistor that is nearest the rear of the scope. The remaining lead will be soldered in the following step.
- () 11. Install the diode-resistor network, included in this kit, on the component side of the Main circuit board. Insert the cathode lead into the circuit board hole used for the lead of R935 (replaced in step 6) that is nearest the rear of the scope. Insert the resistor lead of the new network into the circuit board hole used for the lead of R949 (replaced in previous step) that is nearest the front of the scope. Solder both connections.

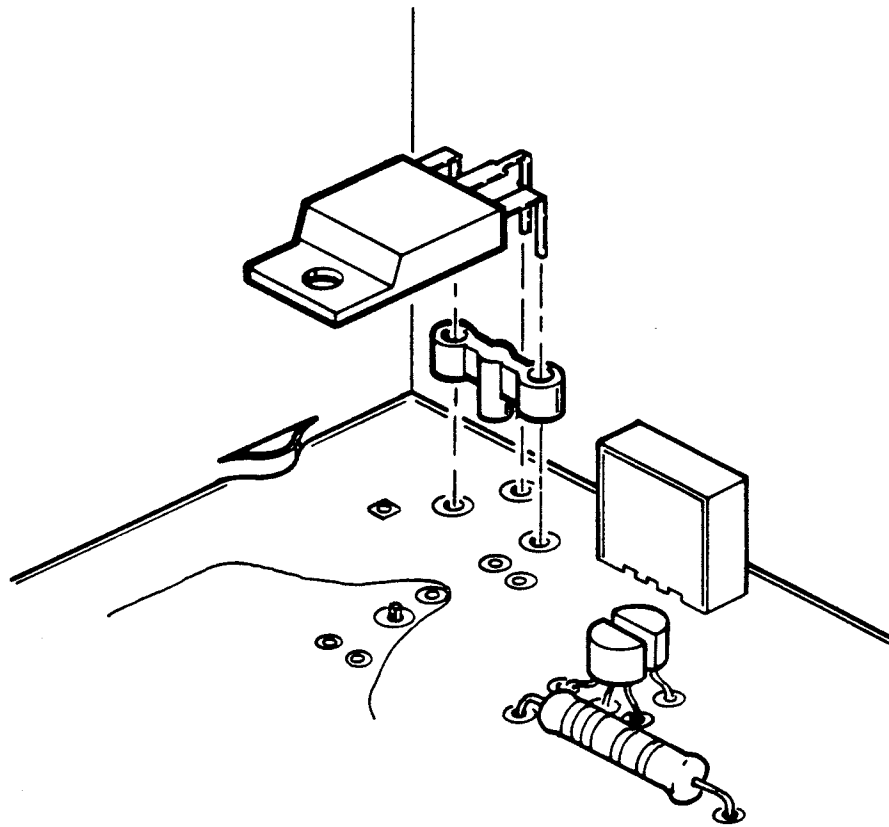

Fig. 1. Location of new diode-resistor network.

- () 12. Replace R908, a $3k\Omega$ 0.25W resistor, with the $2.2k\Omega$ resistor included in this kit.
- () 13. Replace R912, a 549Ω 0.125W resistor, with the 475Ω resistor included in this kit.
- () 14. Replace Q946, Q947, and Q9070 with the new components included in this kit. Q946, Q947 and Q9070 are located on the metal bracket attached to the right rear corner of the chassis. Refer to the parts list on page 3 for circuit and part number information.
- () 15. On the EMI Filter board, replace VR901 and R900 with the new components, included in this kit, swapping their physical locations as the new parts are installed.
- () 16. Replace Q935 with the new SCR, included in this kit, using the included spacer as shown in figure 1.
- () 17. Install the fan motor and electronic module removed in step 5.
- () 18. Install the two electrical shields, removed in steps 2 and 4, on the Main circuit board.

- () 19. Refer to the Performance Check Procedure in the Service Manual and verify product performance.
- () 20. Remove the protective backing from the 050-kit label, included in this kit, and place the label on a clean, flat surface of the rear panel near the serial number tag.
- () 21. Correct the Replaceable Electrical Parts list and the Power Supply, Z-Axis & CRT schematic in the Service Manual with the information provided in the parts list of this kit.

JLG