

067-0594-00 CALIBRATION FIXTURE

Harmonic Generator

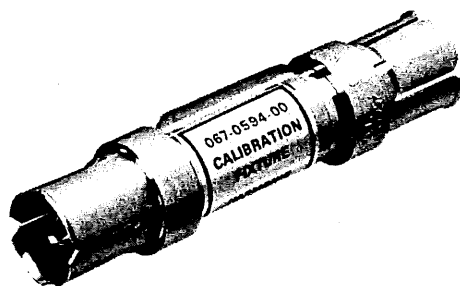

The Tektronix Type 067-0594-00 Calibration Fixture is a Harmonic Generator designed for use (along with Type 067-0595-00 200 MHz Notch Filter) with Tektronix microwave spectrum analyzers.

The Harmonic Generator when used with an accurate frequency source such as the Type 184 Time-mark Generator, provides frequency markers suitable for verifying or calibrating the dispersion (frequency/div) and for checking the RF center frequency dial accuracy of microwave spectrum analyzers. The tunnel diode harmonic generator produces sufficient power so that a relatively low frequency source can be used in the GHz region. A 200 MHz Notch Filter (067-0595-00) is available to reduce IF feedthrough spurious response.

CONTENTS

Section 1 Operating Instructions

Section 2 Maintenance

Section 3 Replacement Parts

 Schematic and Electrical Parts List

 Mechanical Parts List Illustration

 Mechanical Parts List

SECTION 1

OPERATING INSTRUCTIONS

The following procedure describes the operation of the Harmonic Generator when used with a microwave spectrum analyzer. Detailed information for calibrating the spectrum analyzer is described in the instruction manual supplied with the analyzer.

Usually, the Harmonic Generator is used with its associated 200 MHz Notch Filter (Type 067-0595-00 Calibration Fixture). Figure 1-1 shows the interconnections necessary for generating and observing frequency-marks in the frequency domain. The time-mark generator should be connected directly to the harmonic generator to provide a DC bias path for the tunnel diode. A 50 ohm termination (011-0049-01) may be used provided that the signal is sufficient to trip and reset the TD. Care must be taken not to subject the tunnel diode to excessive voltage or current.

The Harmonic Generator is most useful on the sinewave outputs of the Type 184 Time-mark Generator (the actual time-marks are rich in harmonic content). See figure 1-2 for frequency-mark intervals.

Note that the tunnel diode produces a series of frequencies beginning with the fundamental (or driving) frequency and at virtually every harmonic number into the GHz region. For this reason, image signals and harmonic conversion signals will be seen in the spectrum analyzer display. Refer to the analyzer instruction manual for identifying the various responses.

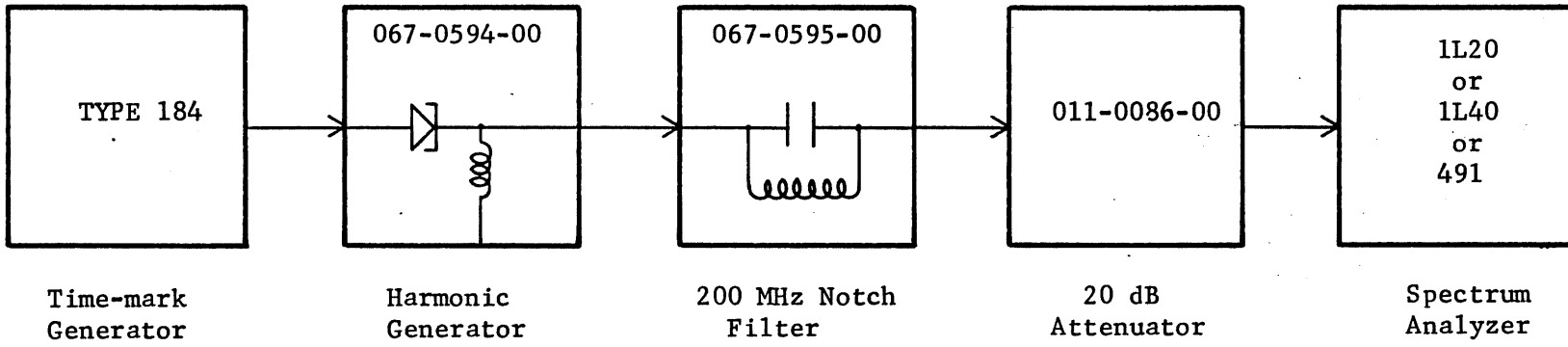

FIG. 1-1

Equipment interconnections for generating and observing frequency-marks.

| TIME-MARKS | FREQUENCY-MARKS |
|-------------|-----------------|
| 2 ns | 500 MHz |
| 5 ns | 200 MHz |
| 10 ns | 100 MHz |
| 20 ns | 50 MHz |
| 50 ns | 20 MHz |
| 0.1 μ s | 10 MHz |
| 0.5 μ s | 2 MHz |
| 1 μ s | 1 MHz |
| 5 μ s | 0.2 MHz |
| 10 μ s | 100 kHz |

FIG. 1-2

Time-mark to frequency-mark conversion

SECTION 2
MAINTENANCE

This section contains information necessary to verify the performance of the harmonic generator.

Connect the equipment as shown in figure 1-1, Operating Instructions. Set the time-mark generator for 10 ns, giving 100 MHz frequency-marks. Tune the spectrum analyzer at 10 MHz/div dispersion to observe 1.5 GHz. The minimum amplitude of the frequency marks in the frequency range of 1.5 GHz to 4.0 GHz should be at least twice the noise amplitude, with the 20 dB attenuator in the circuit.

SECTION 3
REPLACEMENT PARTS

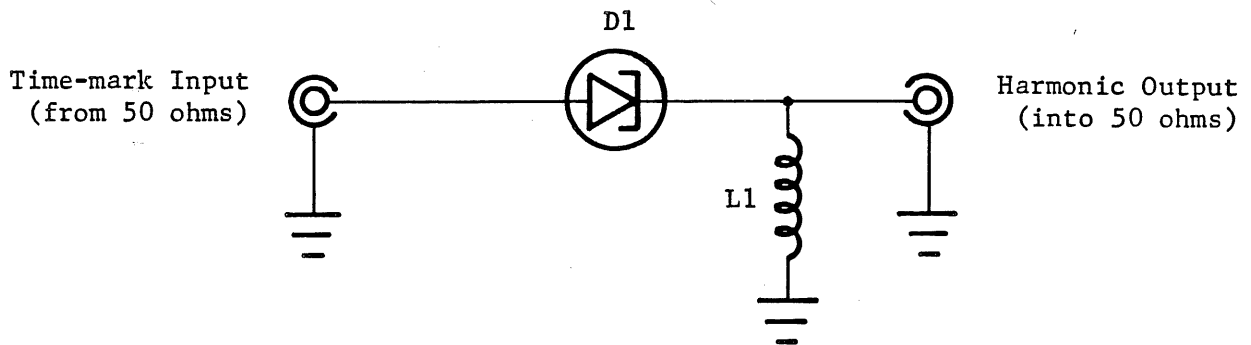

Values are fixed unless marked Variable.

| Ckt. No. | Tektronix Part No. | Serial/Model No. Eff | No. Disc | Description |
|----------|--------------------|----------------------|----------|-------------|
| | | | | Diode |
| D1 | 152-0169-00 | Tunnel | 1N3712 | 1. mA |

EXPLODED VIEW

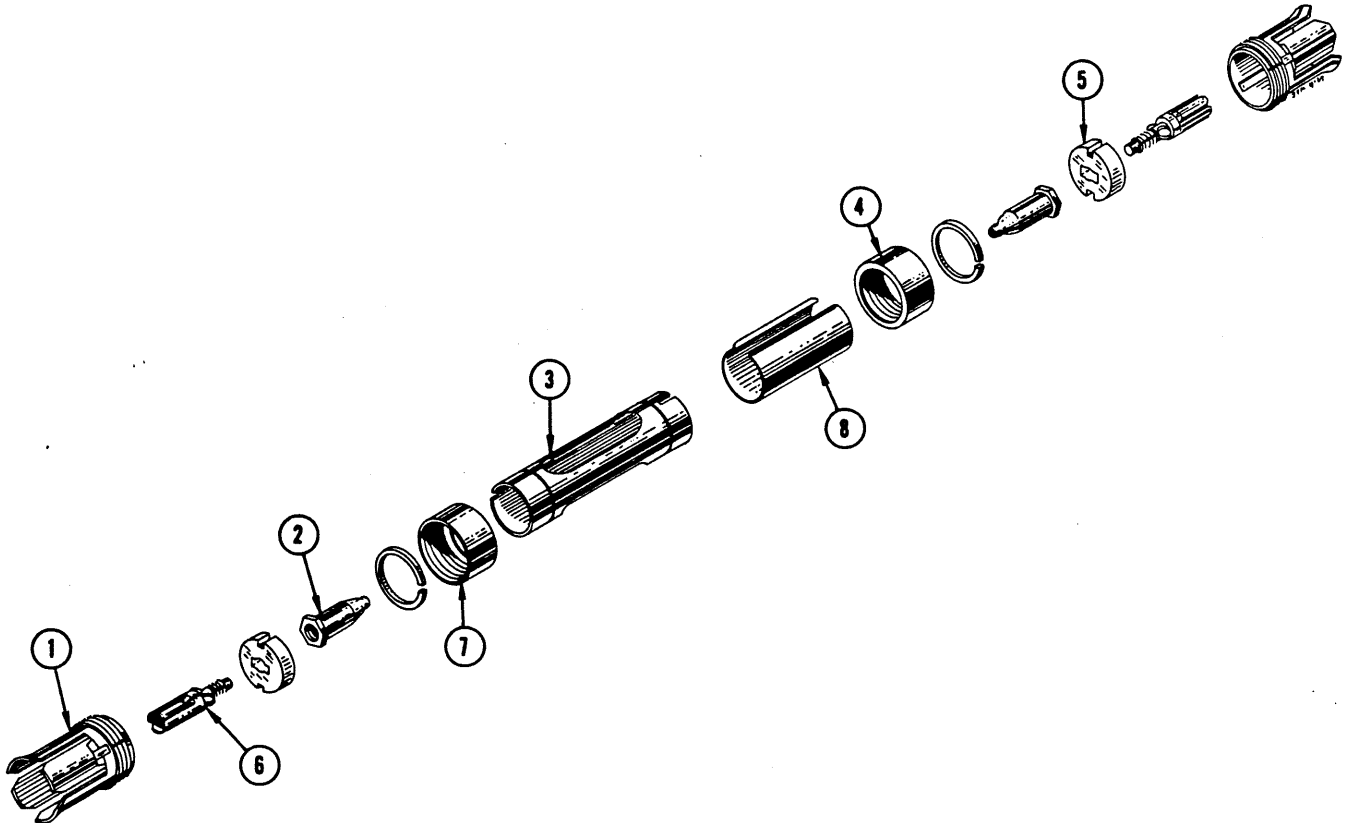

| Fig. & Index No. | Tektronix Part No. | Serial/Model No. Eff | No. Disc | Q t y | | | | | | Description | |
|------------------------|-----------------------|-------------------------|-------------|-------------|---|---|---|---|---|-------------|-----------------------------------|
| | | | | | 1 | 2 | 3 | 4 | 5 | | |
| 1 | 132-0002-00 | | | | | | | | | | |
| 2 | 132-0027-00 | | | | | | | | | | 2 SLEEVE, conductor, outer |
| 3 | 132-0074-00 | | | | | | | | | | 2 INNER TRANSITION |
| 4 | 132-0001-00 | | | | | | | | | | 1 SHELL |
| 5 | 132-0045-00 | | | | | | | | | | 2 NUT, coupling |
| 6 | 132-0029-00 | | | | | | | | | | 2 INSULATOR, plastic |
| 7 | 132-0007-00 | | | | | | | | | | 2 INNER CONDUCTOR |
| 8 | 337-0403-00 | | | | | | | | | | 2 SNAP RING |
| | 334-1392-00 | | | | | | | | | | 1 SHIELD |
| | | | | | | | | | | | 1 TAG, identification (not shown) |