

SERVICE SUPPORT DOCUMENT

Program Type	SERVICE UPDATE PLAN #3010
Product Type	2213,2215
Service Support Group	BEAVERTON SERVICE SUPPORT

Originator	ROY LINDLEY, SPS <i>Roy Lindley</i>
Approvals	TODD PAULUS, SPM <i>Todd E Paulus</i>
Date	APRIL 14, 1983
Revision	

SERVICE UPDATE PROGRAM 3010I. PROGRAM OVERVIEW

- A. This modification is mandatory on all units within the serial number ranges, and must be implemented as quickly as possible. CRT degradation from the high filament voltage will seriously reduce the CRT life. The longer a unit remains unmodified, the greater the risk of requiring CRT replacement under this program.

Due to the urgency of this modification, the customer letter emphasizes accomplishing the mod by August 31, 1983. However, this program will remain in effect indefinitely and all units must be modified whenever they come into a service location.

- B. This modification will reduce the CRT filament voltage, and bring it back to the design center, 6.3 Volts. This will prevent premature CRT failure from low cathode emission.
- C. All customers with units within the serial number range will be notified by letter. U.S. customers will be informed directly from Beaverton by the 2200 Series Marketing group. International customers will be notified via their local subsidiary or distributor.

The letter will offer the customers two methods to upgrade their units. Complete instructions will be enclosed which will allow self-repair by the customer; or, if the customer prefers, directions to contact the local Tektronix facility to schedule repair by Tektronix.

- D. The customer letter (copy attached) emphasizes self-service installation of this modification, since it requires no new parts and is not difficult to install. The intent was to reduce the impact on the Tektronix field service organization while ensuring the largest number of 2213/2215 instruments are modified as early as possible. Some of your self-service customers may request replacement CRT's or transformers in the course of complying with the modification. Local Sales/Service personnel will have to judge whether or not the request is specifically related to this update program.

II. MODIFICATION DESCRIPTION

- A. To reduce the voltage, one turn of the filament winding is unwound and redressed (see attached instructions).

With this modification the transformer P/N changes to 120-1348-01.

Following modification, the -8.6V supply should be checked and the CRT BIAS, Focus and Astigmatism checked for normal operation.

- B. All units in the affected serial number ranges must be modified. Inspect all incoming 2213/2215 and 2235/2236 DEMO filament transformers. If the transformer has already been modified as indicated by the wire dress, or it is marked with P/N 120-1348-01, the modification has already been installed.

All CRT's should be checked to ensure they have sufficient intensity range to provide acceptable display brightness at all sweep rates. Focus and Astigmatism adjustments must operate within their normal ranges.

Any CRT with low intensity and/or poor focus caused by low cathode emission is to be replaced at no charge to the customer, under this Service Update Program.

- C. Detailed modification instructions are included as an attachment to this document.

The final decision as to whether or not the CRT is still within its useful life will remain with the Local Sales and Service personnel in accordance with the customers needs.

- D. A quantity of identifying labels will be provided to each service location. It must be attached as per the mod instructions on each unit as the modification is completed.

The customer letter and instructions will not include this label. Therefore, each customer unit coming through the service center must be examined to verify whether or not it needs to be modified. Identification can be made either by the transformer part number upgraded to 120-1348-01 or the transformer lead being redressed as per Figure 3 of the mod instructions.

CRT RELIABILITY IMPROVEMENT

For the Following TEKTRONIX Oscilloscopes

2213 Serial Numbers B010100 - B029389
 2215 Serial Numbers B010100 - B031639

INSTRUCTIONS:

WARNING

Before proceeding, ensure the power switch is in the off position then disconnect the instrument from the power source.

CABINET REMOVAL

- () 1. If the instrument has a detachable power cord, disconnect it from the instrument. Remove the screw from the right rear side of the cabinet and the two screws from the rear panel.
- () 2. Remove the rear panel. (On instruments with non-detachable power cords, feed the cord through the cutout as the rear panel is removed.)
- () 3. Slide the instrument forward out of the cabinet.

HIGH VOLTAGE SHIELD REMOVAL

- () 4. Set the instrument on its left side (as viewed from the front panel) to gain access to the bottom side of the Main circuit board.
- () 5. Remove the screw securing the plastic high voltage cover to the Main circuit board. Press down on rear of cover, slide away from chassis, and remove.
- () 6. Remove the screw securing the high voltage shield to the Main circuit board (located below rear corner of cutout in right chassis side, adjacent to TP500).
- () 7. Set instrument down and remove the two flathead screws securing the left rear of the high voltage shield to the rear of the chassis frame.
- () 8. Remove the screw securing the front, upper right corner of the shield to the chassis.
- () 9. Remove the screw from the front, upper left corner and rotate the plastic support bracket away from the high voltage shield.

- () 10. If present, remove the panhead screw from the perforation in the front of the high voltage shield (second row of perforations, directly above CRT anode lead).
- () 11. Remove screw securing the upper, right rear corner of the shield to the rear of the chassis.
- () 12. Lift the shield up and out of the chassis frame by removing the right rear corner first.

PREREGULATOR CIRCUIT BOARD ASSEMBLY REMOVAL

NOTE

2213 instruments, SN B020100 and up, and 2215 instruments, SN B022000 and up, have a Preregulator circuit board assembly mounted above T940. Also, any instrument with Option 48 installed has this circuit board. To facilitate access to T940, remove the Preregulator assembly from these instruments by performing steps 13 through 16.

- () 13. Disconnect the following wires with quick disconnect terminals from the Preregulator circuit board:
 - () a. The gray-black-brown wire from P801.
 - () b. The gray-black-red wire from P802.
 - () c. The gray-black-orange wire from P803.
 - () d. The gray-black-yellow wire from P804.
- () 14. Remove the two screws securing the Preregulator circuit board mounting brackets to the chassis (one at the upper rear of the frame and one on the right side, near the right rear corner).
- () 15. Remove the screw securing the Preregulator circuit board to the aluminum heat sink bracket. Access to the screw is through the hole in the clear plastic shield near the front right corner of the board.
- () 16. Lift the Preregulator circuit board assembly from the instrument.

FIG 1

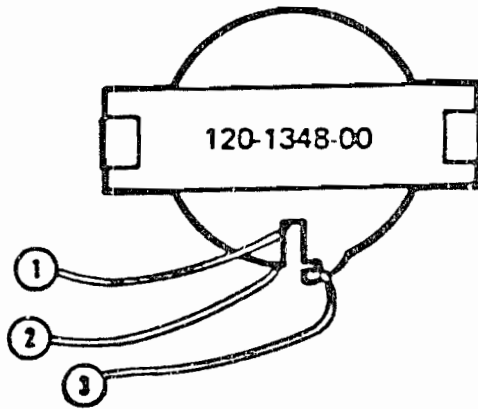

FIG 2

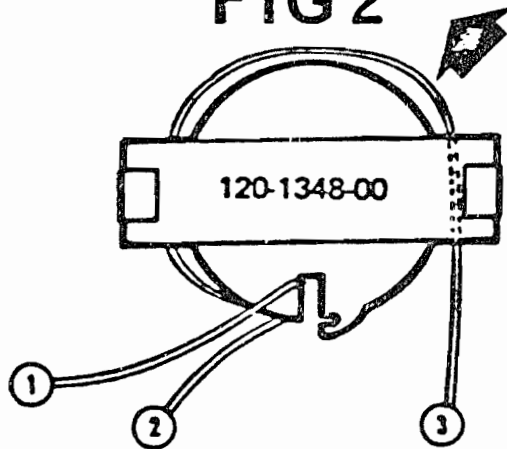
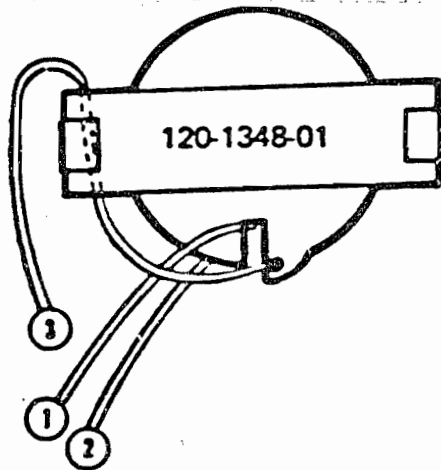

FIG 3



T940 Heater Voltage Winding Modification.

TRANSFORMER MODIFICATION

- () 17. Locate the lead of T940 labeled (3) in Fig. 1. Unsolder this lead from the Main circuit board, noting location for later reassembling.
- () 18. Unhook wire (3) from small retaining clip in transformer bobbin and unwind one complete turn. Refer to Fig. 2.
- () 19. Snap wire back into the retaining clip and pull tight.
- () 20. Cut off 3 inches of lead. Trim 3/16 inch insulation off remaining lead. Take care not to nick or cut the wires.
- () 21. Dress wire (3) back through the transformer core as indicated in Fig. 3.
- () 22. Tin the stripped lead and resolder it to the Main circuit board pad, noted previously. The dress of the wire is not critical except it should not be pulled tight against the edge of the transformer core.
- () 23. Change the part number on top of the transformer from 120-1340-00 to 120-1348-01.

PERFORMANCE CHECK AND REASSEMBLY

- () 24. Reassemble the instrument by performing the reverse of the procedure in steps 4 through 16.
- () 25. Refer to the Performance Check and Adjustment sections of your Service Manual and make any necessary checks and adjustments. Especially check the -8.6V supply and the grid bias adjustment.
- () 26. Reinstall the cabinet and rear panel by performing the reverse of the procedure in steps 1 through 3.
- () 27. Remove the protective backing from the provided label * and apply it to a clean dry area on the plastic rear cover. This label will be used to identify units that have been modified.

* Each service location will be provided an initial quantity of the labels. Additional labels can be obtained from your representative listed below:

U.S.	Roy Lindley	C1-866
AM/PAC	Fred VanderMeulen	51-297
Europe	Wim Schaap	TekEurope

**SERVICE
SUPPORT
DOCUMENT**

Program Type	"MANDATORY" SERVICE UPDATE PROGRAM # 3010
Product Type	2213 / 2215 OSCILLOSCOPES
Service Support Group	CLARK COUNTY SERVICE SUPPORT

Originator	Roy Lindley, Service Program Specialist <i>Roy Lindley</i>
Approvals	Todd Paulus, Service program Manager <i>Todd Paulus</i>
Date	April 27, 1933
Revision	REVISION # 1

2213/2215 CRT FILAMENT VOLTAGE

I. AFFECTED SERIAL NUMBER RANGES, CORRECTION

The "official" serial number ranges as listed in the Update Plan are:

2213	B010100 - B029389
	200001 - 203411
2215	B010100 - B031639
	200001 - 206198

However, the upper limit is only the best estimation of the actual starting point due to the very large number of units "in process" at the time of the modification and rework.

Units within the serial number ranges listed below **MUST BE CHECKED** to see if they have already been reworked by Manufacturing. Methods of identification are listed in the next section.

Check these units for prior modification before implementing the filament mod.

2213	B027000 - B030000
	202500 - 203411
2215	B029000 - B032000
	205300 - 206198

NOTE:

After the customer letter is distributed, ALL UNITS WILL HAVE TO BE EXAMINED to verify whether or not the mod has to be installed.

If the unit has already been modified, add the "M50226" tag. If the unit has not been previously reworked, perform the mod and apply the tag.

NOTE:

APPLY THE TAG IN THE LOWER LEFT CORNER (as viewed from the rear) OF THE METAL REAR SUBPANEL. The tags will not stick securely on the plastic back panel. Place the tag on the metal subpanel lower left corner so that the tag will be visible through the slotted vent in the plastic rear panel.

IDENTIFICATION NO

M50226

ZENITH ELECTRONICS CORPORATION

II. IDENTIFICATION METHODS

Scan by Zenith

Modified units will have AT LEAST ONE of the identifying changes as listed below. Most modified units will have several of the visible changes.

A few modified units had the wire redressed as the original part after being moded. Look for the "01" part number.

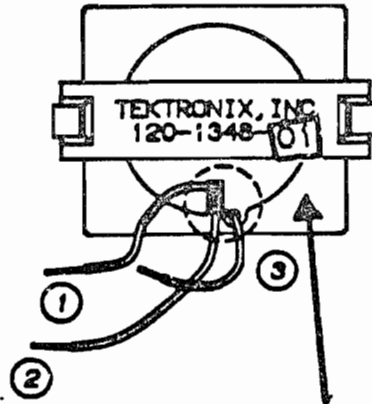

The "00" was changed to "01" with a white stick on label.

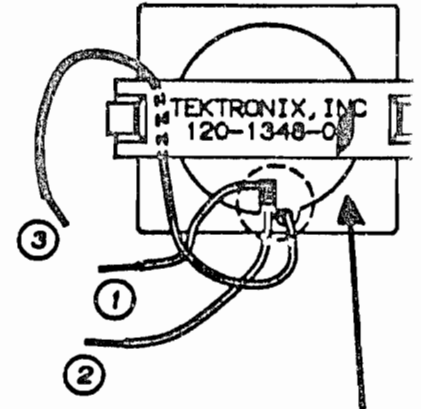

The last "0" in the P was changed to a "1" with a black felt tip marker.

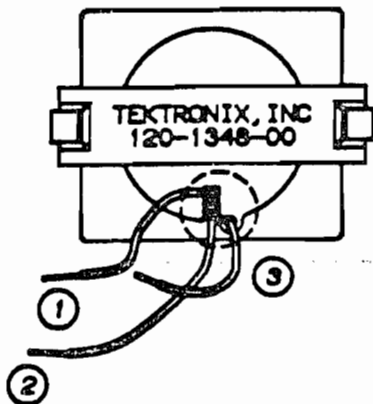

Wire # 3 in UNMODIFIED units goes directly from the notch to the circuit board connection.

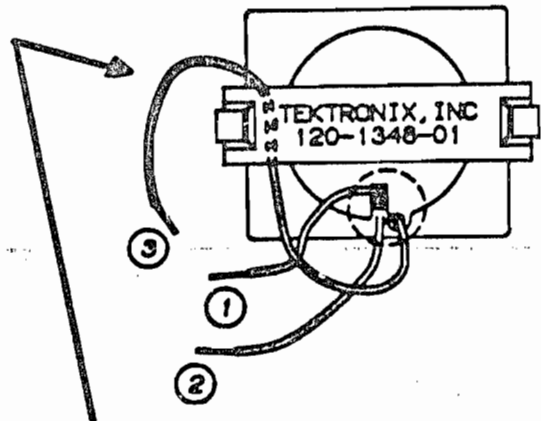

Wire # 3 in a MODIFIED unit is looped through the transformer bobbin and then resoldered to the same circuit board connection point.

Wires # 1 and 2 are not changed. They remain connected as before the mod.

2200 SERIES FILAMENT VOLTAGE MODIFICATION

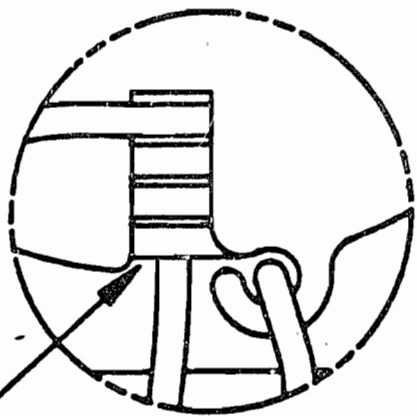
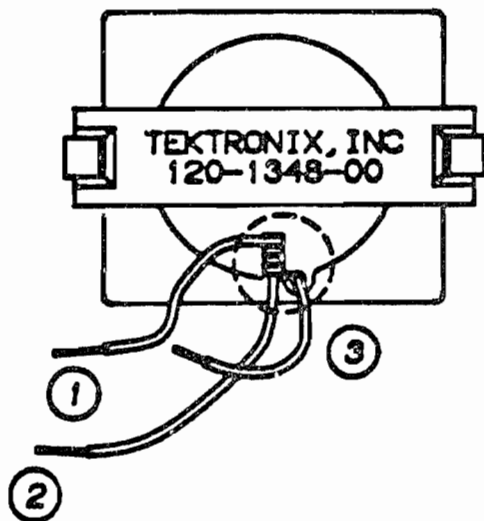

FIGURE 1
(BEFORE MODIFICATION)

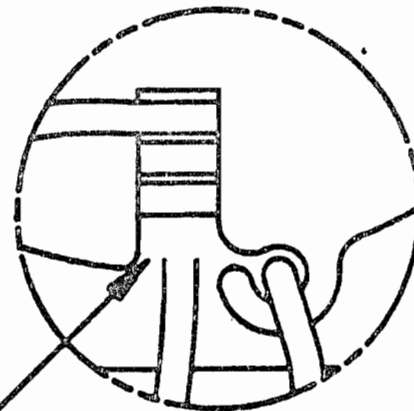
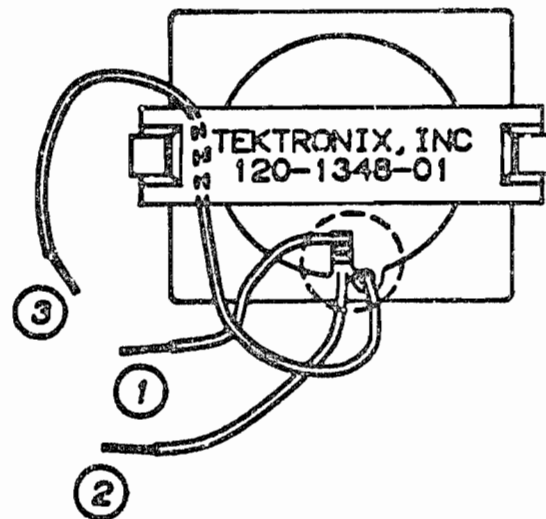

FIGURE 2
(AFTER MODIFICATION)

Close examination of the notch in the top of the transformer should show the space left when the first wrap is unwound during implementation of the modification. (FIG 2) An unmodified transformer will show the wires all the way out to the edge as in FIGURE 1.

III. FILAMENT VOLTAGE MEASUREMENT

As a last resort in verifying whether or not a unit has been modified, the filament voltage can be measured if you use the precautions as listed below:

1. With the instrument power removed, unsolder the two (2) brown filament wires from the Main circuit board. THIS MUST BE DONE TO REMOVE THE 2000 VOLTS D.C.
2. The "approximate" filament voltage can be read by connecting an AC RMS meter across the DISCONNECTED FILAMENT WIRES.

The Peak to Peak AC signal voltage can be measured by connecting a test scope probe tip and ground lead across the DISCONNECTED filament wires.

3. The typical readings as measured on an AC RMS meter such as a 213 Scope/DMM, DM501A or DM502A are listed below. Other non-RMS meters such as a DM501 will produce different and probably higher readings. Peak to Peak waveform readings were done using a 468 scope.

	<u>AC RMS VOLTS</u>	<u>P TO P VOLTS</u>
UNMODIFIED TRANSFORMER	7.0 - 7.3	15.3 - 15.9
Correct mod, 1 turn unwrapped, redressed	6.1 - 6.4	13.5 - 14.0
Modified twice, 2 turns unwrapped, redressed	4.4 - 4.6	9.6 - 10.0

4. After completing the measurement, resolder the 2 filament wires back to the same Main circuit board pads. The wire from the transformer clip-in notch (marked as # 3 in the drawings) passes through the transformer bobbin as shown and solders to the front of the 2 pads (nearest the HV multiplier) from which the wires were unsoldered. The other filament lead should be resoldered to the pad directly behind the other pad.

Regards,

Roy Lindley

Roy Lindley
Clark County Service Support
C1 - 866 Ext 5383