

P6576
4921
2215

SERVICETEKNOTES

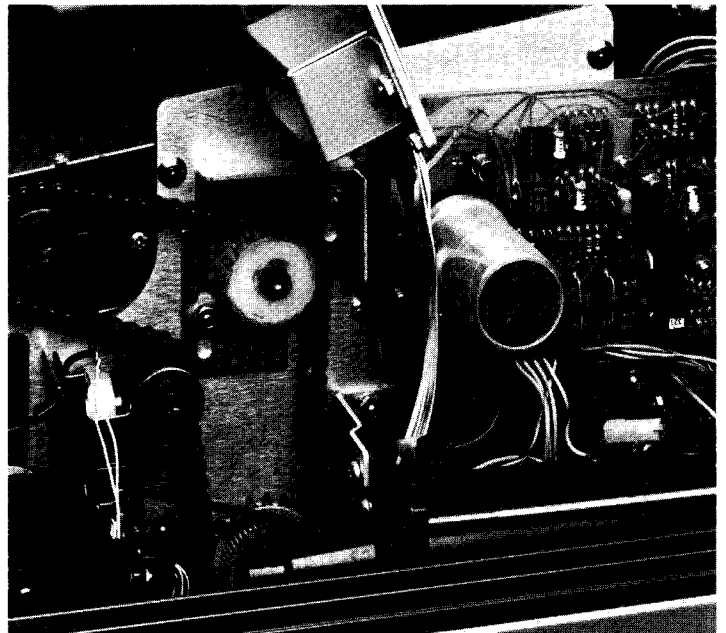
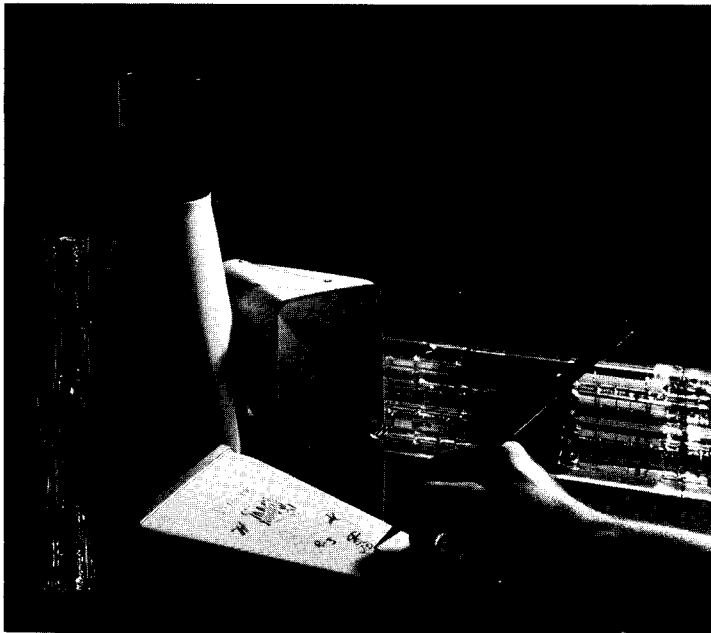
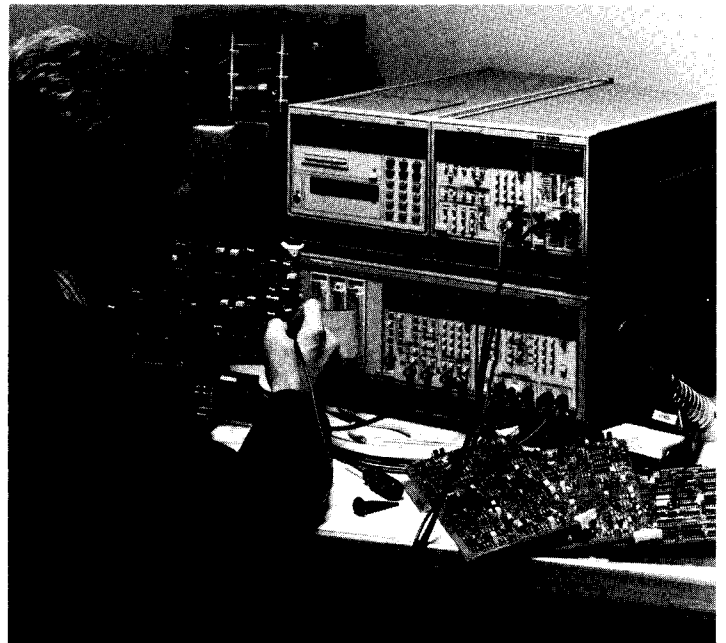

The Tektronix Service Organization firmly supports a policy of assuring continued utility of products sold by Tektronix.

This publication is meant to provide technical information to the customer who has decided to maintain his own Tektronix products. It contains product servicing information and is written for the technician.

Articles are submitted primarily by Service Support Staff Engineers thoroughly familiar with the products they support. SERVICE TEKNOTES also encourages you, the user, to submit articles for publication. If you have knowledge of a technique, procedure or idea that enables you to service your Tektronix product more effectively, write it down so others may benefit from your experience.

Articles for publication should be submitted directly to:

Tektronix, Inc.
P.O. Box 500
Beaverton, Oregon 97077

Attention: Janet Hemenway
SERVICE TEKNOTES Editor
Delivery Station: 56-037

SERVICE TEKNOTES is distributed by Service Administrative Support free of charge to customers who maintain their own Tektronix equipment. A customer may be added to the distribution list by applying through his local Tektronix Sales Engineer.

Copyright ©1981, Tektronix, Inc. All rights reserved. Printed in U.S.A. Tektronix products are covered by U.S. and foreign patents, issued and pending. Information in this publication supersedes that in all previously published material. Specification and price change privileges reserved. TEKTRONIX, TEK, SCOPE-MOBILE, and  are registered trademarks of Tektronix, Inc. TELEQUIPMENT is a registered trademark of Tektronix U.K. Limited.

The Editor and staff of SERVICE TEKNOTES provide the material in this publication as a service to users of Tektronix Products. While we have tried to be diligent in assuring the accuracy of the material which we have printed, we cannot guarantee its accuracy. Neither SERVICE TEKNOTES, its editor and staff, Tektronix, Inc., nor its representatives assume any responsibility for the use of the material printed in SERVICE TEKNOTES; nor can we assume any responsibility for any errors or for the resulting effects of any errors.

TABLE OF CONTENTS

CUSTOMER SERVICE TRAINING CLASSES.	1
FG502 VCF IMPROVEMENT.	1
L1 MANUAL ERROR FOR K108, K118, K138 PART NUMBERS.	1
- PG506 MAINBOARD REPLACEMENT.	2 -
S-3200 - D70 OFFSET, SKEWING IMPROVEMENTS.	2
S-3200: PROBER, SIGNAL INTERFACE PART AVAILABLE	2
147A/149A MULTIBURST FREQUENCY ADJUSTMENT.	2
49X/634 -- NEW CRT MOUNTING SCHEME PRECAUTIONS	3
- 492/P CENTER FREQUENCY KNOB (A38 S2035) REPLACEMENT PARTS.	4 -
- 492/P JUMPERS ON PRESELECTOR DRIVER BOARD P/N 670-5552-03.	4 -
- 492/P OPT. 3 VARIABLE RESOLUTION MODULE REPLACEMENT KIT (050-1466-00).	5 -
- 492/P VARIABLE RESOLUTION MODULE REPLACEMENT KIT (050-1467-00)	5 -
603A, 604A HIGH VOLTAGE CAPACITOR MODIFICATION 43875	5
1470/1474 BURST AMPLITUDE ADJUSTMENT AND GEN LOCK FREQUENCY CHANGE	6
2213, SWEEP START ABERRATION REDUCED	8
- 2215, DTP MINIMUM SETTING.	8 -
- 2215, REDUCED TRACE NOISE IN CHOP MODE	8 -
- 2215, 50 KH _z B TRIGGER OPERATION	8 -
4016-1, GMA125 CRT; BONDED GLASS IMPLOSION SHIELD.	8
4611/4054: GRAPHIC SYSTEM HANGS WHEN COPIER IS TURNED OFF12
4611/12: TROUBLESHOOTING THERMAL FUSE FAILURE12
7L5 DIGITAL STORAGE IMPROVEMENT KIT (P/N 040-0872-02).13
7L5 U4702 REPLACEMENT KIT (050-1500-00).13
067-0916-00 VIDEO AMPLITUDE CALIBRATOR (VAC) & 067-1011-00 DIGITAL SWEEP GENERATOR13

CUSTOMER SERVICE TRAINING CLASSES

Tektronix product service training classes are designed for technicians responsible for calibrating, troubleshooting and servicing Tektronix products.

TM504/DC503A/DM502A/PG506/SG503/TG501 Calibration Package Class

January 4-8, 1982 - Chicago, IL
February 22-26, 1982 - Beaverton, OR
March 15-19, 1982 - Boston, MA

475B/475Portable Oscilloscope Class

January 4-8, 1982 - Beaverton, OR
March 1-5, 1982 - Beaverton, OR
March 8-12, 1982 - Boston, MA
March 8-12, 1982 - Beaverton, OR

7704A/7904/7633Laboratory/Storage Oscilloscope Class

January 11-22, 1982 - Beaverton, OR
January 25-February 5, 1982 -
Dallas, TX
March 8-19, 1982 - Beaverton, OR

7D01/DF2Logic Analyzer Class

February 15-19, 1982 - Beaverton, OR

492Portable Spectrum Analyzer Class

January 4-22, 1982 - Beaverton, OR

7912ADProgrammable Digitizer Class

February 8-19, 1982 - Beaverton, OR

650HR/520A/1485TV Monitor Class

February 8-19, 1982 - Beaverton, OR

4010/4014/4631Graphic Terminal Class

January 4-8, 1982 - Beaverton, OR
January 4-8, 1982 - Dallas, TX
February 15-19, 1982 - Rockville, MD
March 15-19, 1982 - Beaverton, OR

4052/4054/4907Advanced Graphic System Class

January 4-15, 1982 - Beaverton, OR

4662/4663Graphic Plotter Class

January 18-22, 1982 - Beaverton, OR

4025/4027Raster Scan Graphic Terminal Class

January 4-15, 1982 - Santa Clara, CA
February 22-March 5, 1982 -
Beaverton, OR

8550Microcomputer Development Lab Class

January 25-February 5, 1982 -
Beaverton, OR

4081Interactive Graphic Terminal Class

March 29-April 9, 1982 -
Beaverton, OR

GMA101/GMA102A/GMA125Graphic Display Monitors Class

March 29-April 2, 1982 -
Beaverton, OR

For more information or to register for a class, call Tektronix Service Training at (503) 642-8422.

D.H.(11-81)

FG502 VCF IMPROVEMENT

Serial Numbers Affected: Below B050740

Some FG502's below the affected serial number may not shift Output Frequency 1000:1 with 10V or less as specified.

To correct this problem, change R125 from 10K ohm (P/N 321-0289-00) to 9.41K ohm (321-0632-00).

W² Issue 11-20

L1 MANUAL ERROR FOR K108, K118, K138 PART NUMBERS

The L1 manual, P/N 070-1957-00, lists K108, K118, K128 and K138 as 148-0074-04 parts. This is incorrect; the part number for the relays should be 148-0107-04.

W² Issue 11-19

PG506 MAINBOARD REPLACEMENT

Serial Numbers Affected: All instruments below B04000.

The new main board assembly, P/N 672-0455-02, is not a direct replacement and requires kit #050-0764-04 for installation. If your instrument does not have relay circuit board, P/N 670-4328-01, installed, then you will also need to order Kit #040-0774-01.

W² Issue 11-21

S-3200 - D70 OFFSET, SKEWING IMPROVEMENTS

REFERENCE MODIFICATION M4266Z

Resistor and capacitor changes will improve the adjustment ranges for D70 Sector Cards. These changes will increase the adjustment range for skewing force phases, compare phases, and buffer offsets.

Installation of this mod to the D70 Pin Electronics Card 670-5347-02 will change the board revision level to 670-5347-03. The D70 Sector Card Assembly 672-0687-03 changes to 672-0687-04. The 670-5347-03 and 672-0687-04 are direct replacements for the 670-5347-02 and 672-0687-03 respectively.

Change Information: D70 Pin Electronics Card

C410, C411:

10pf, 5%, 200v (283-0175-00) replaced by 15pf, 20%, 50v (283-0069-00)

C412, C413:

10pf, 5%, 200v (283-0175-00) replaced by 18pf, 5%, 50v (283-0159-00)

R444:

75K ohm, 1%, 0.125w (321-0373-00) replaced by 59 ohm, 1%, 0.125w (321-0363-00)

R453:

150K ohm, 1%, 0.125w (321-0306-00) replaced by 4.99K ohm, 1%, 0.125w (321-0260-00)

W² Issue 11-21

S-3200: PROBER, SIGNAL INTERFACE PART AVAILABLE

The Signal Interface (021-0218-00) is used to interface the Electroglas and Teledyne probers to the test station. Serviceability of this unit has been enhanced by a new replaceable part. The interface includes 60 each, 94 ohm, RF cable assemblies. Individual cables with connectors attached may now be replaced. Order Part Number 179-2293-00.

Previously these 15.38 inch cables did not come as replaceable assemblies with the connectors. This presented a service problem since the RF cables cannot be soldered to, and special crimping tools are required to install the connectors.

W² Issue 11-22

147A/149A MULTIBURST FREQUENCY ADJUSTMENT

Reference: 147/149A Instruction Manual P/N 070-2029-00

The present instruction manual suggests an adjustment method for the frequencies of the multiburst packets using an oscilloscope to adjust in the time domain. The chart on Page 3-25 of the manual lists tolerances allowed for the generator/in-

(ARTICLE CONTINUED ON THE NEXT PAGE)

147A/149A MULTIBURST FREQUENCY ADJUSTMENT (cont.)

serter's specs, discounting any possible scope inaccuracies.

To more accurately set the frequencies required and discount any scope anomalies, the following method is suggested:

- A. Connect the OUTPUT from an FG502 to one channel of your Dual-Input scope vertical input.
- B. Connect the TRIG OUT from the FG502 to a digital counter (DC 503A Opt. 1).
- C. Connect the FULL FIELD OUT of the 147A/149A under test to the other input of your scope dual-input vertical.
- D. Adjust the FG502 frequency for the desired multiburst packet frequency to be adjusted, using the DC503A as the frequency meter.
- E. Overlay the two traces on the scope using the chop or alternate mode as appropriate and adjust the 147A/149A as desired.

A possible alternative is to accurately characterize the timebase of the scope you are using to make these adjustments.

A note will be added to the manual alluding to possible inaccuracies.

W² Issue 11-22

49X/634 -- NEW CRT MOUNTING SCHEME PRECAUTIONS

The 492/P, 496/P, and 634 are using a new method of mounting the CRT. This method is based on having four wedges epoxied to the CRT funnel and the use of four plastic blocks, mounted to the instrument's front casting, to engage these wedges. The position of the plastic blocks can be adjusted by tightening their mounting screws.

TO INSTALL A CRT THE PROCEDURE LISTED BELOW MUST BE FOLLOWED TO INSURE PROPER INSTALLATION.

STEP ONE: Place the instrument on it's rear panel.

STEP TWO: Insure that the four CRT mounting blocks, on the front casting, are in place. DO NOT ENGAGE MORE THAN TWO THREADS TO HOLD BLOCKS IN PLACE.

STEP THREE: Place the CRT into the instrument, seating the CRT wedges into the mounting blocks.

STEP FOUR: Put the bezel casting and the implosion shield in place, "BE SURE THAT THERE IS ADEQUATE CLEARANCE BETWEEN THE CRT FACEPLATE AND THE BEZEL CASTING, THE BEZEL CASTING MUST BOTTOM IN THE INSTRUMENTS FRONT CASTING."

"WARNING!"

IT IS VERY IMPORTANT THAT THE FOUR MOUNTING BLOCKS HOLDING THE CRT ARE LOOSE ENOUGH SO THE BEZEL RETAINING SCREWS CAN BE COMPLETELY TIGHTENED WITHOUT THE BEZEL COMING IN CONTACT WITH THE CRT FACEPLATE, IF THEY MAKE CONTACT, DAMAGE TO THE CRT AND/OR FRONT CASTING WILL OCCUR.

STEP FIVE: Tighten the CRT mounting block screws, using a torque screwdriver, a little at a time in a crisscrossing pattern (i.e. Upper Left to Bottom Right, Upper Right to Bottom Left, etc.) to assure even pressure. DO NOT EXCEED 8-10 IN/LBS OF TORQUE.

While tightening the screws, make sure that the CRT stays centered in the mounting blocks.

(ARTICLE CONTINUED ON THE NEXT PAGE)

**49X/634 -- NEW CRT MOUNTING SCHEME
PRECAUTIONS (cont.)**

"CAUTION!"

THE FINAL TORQUE FOR THE FOUR MOUNTING BLOCK SCREWS MUST NOT EXCEED 8-10 IN/LBS.

When this procedure is followed a very rugged mounting system exists. CRT's have been subjected to 150g shocks without failure.

When this installation procedure is not followed, the faceplate can be chipped, or in extreme cases, it will crack. These failures will not necessarily happen during installation, in most cases it will occur in the field due to a minor shock to the instrument. There have been a number of field failure reports that seem to indicate failures due to incorrectly installed CRT's. The most common reported failures have been "Cracked Faceplate" and/or "Gassey". One "Gassey" CRT, returned from the field, was found to actually have a cracked faceplate which was not visible to the naked eye.

W² Issue 11-21

**492/P CENTER FREQUENCY KNOB (A38 S2035)
REPLACEMENT PARTS**

Due to the high replacement cost of (A38 S2035) the Center Frequency Knob for the 492/P, some of the internal parts were made replaceable. Refer to the figure below for the parts list and schematic locations.

492/492P		A38	} { DS 1029 150-0093-01 Q 1037 151-0629-00 Q 1031 151-0629-00
496/496P		A48	

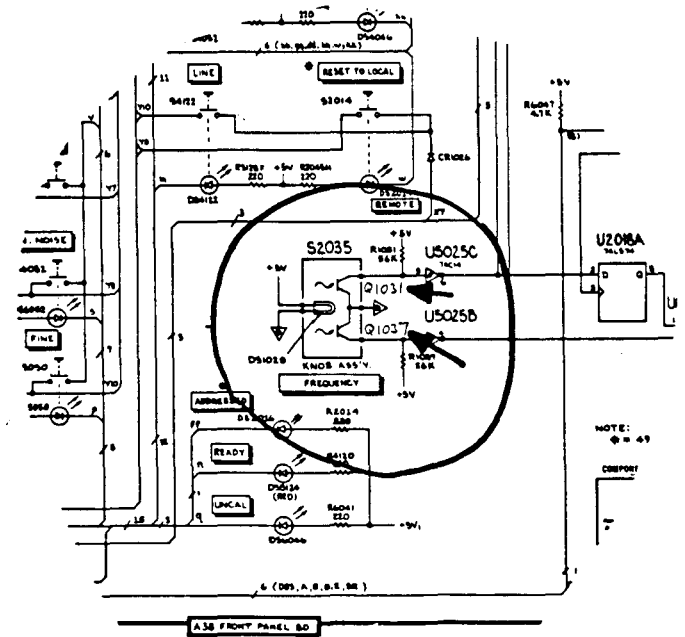

W² Issue 11-19

**492/P JUMPERS ON PRESELECTOR DRIVER
BOARD P/N 670-5552-03**

The new Preselector Driver has two plugs on it to match it to the particular first LO Driver and Mother Board with which it is being used.

1. In post major mod 492's (B03XXXX and above) and all 492/P's, P5052 should have a jumper on it and P5065 should be open. This connects the Peaking control to the Preselector Driver via the first LO Driver programmable peaking output on Pin 46.
2. In pre major mod 492's (below B03XXXX) with a first LO Driver, 670-5550-01 or -00, P5065 should have a jumper on it and P5052 should be open. This connects the Peaking control to the Preselector Driver via Pin 58 on the Mother Board connector. Pin 46 on the first LO Driver has no connection on the -01 board.

Presently in 492's with -06 Mother Boards, the Peaking control will work

(ARTICLE CONTINUED ON THE NEXT PAGE)

492/P JUMPERS ON PRESELECTOR DRIVER BOARD P/N 670-5552-03 (cont.)

with the jumper on either plug since there is an extra run in the -06 Mother Board between Pins 58 on the LO Driver, and Preselector Driver (see accompanying schematic). Connect the jumpers as in #1 above.

If the jumpers are incorrect on a 492/P, the Peaking control will be useable, but the Programmable Peaking will not work.

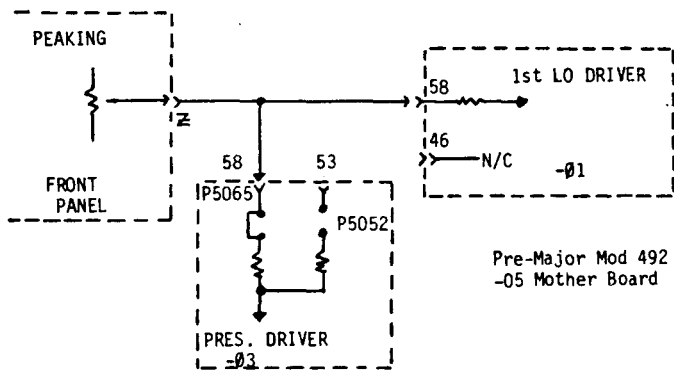

W² Issue 11-19

492/P VARIABLE RESOLUTION MODULE REPLACEMENT KIT (050-1467-00)

Serial Numbers: B010100 to B019999

An 050-1467-00 replacement kit has been set-up to replace the Variable Resolution Module in the 492/P. The Variable Resolution Module, P/N 644-0163-00, was replaced by a New Variable Resolution Module, P/N 644-0163-04. The new, redesigned Variable Resolution Module requires a new calibration procedure which is included in the kit.

W² Issue 11-19

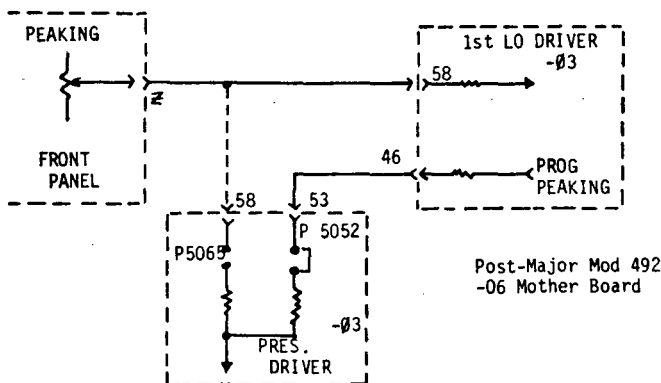

W² Issue 11-20

492/P OPT. 3 VARIABLE RESOLUTION MODULE REPLACEMENT KIT (050-1466-00)

Serial Numbers: B010100 to B019999

An 050-1466-00 modification kit has been set-up to replace the Variable Resolution Module in the 492/P Option 3 Spectrum Analyzer. The kit contains the new

603A, 604A HIGH VOLTAGE CAPACITOR MODIFICATION 43875

The high voltage capacitors used in the 603A and 604A monitors have shown a high rate of failure. This is despite the fact that they are rated at 5kv and used in a 3.5kv application. Capacitors C580 and C581 tend to shut the high voltage supply down when they fail. Capacitor C565 sometimes causes CRT damage when it fails.

To solve the problem, a new vendor has been approved to supply a similar component (Tek P/N 283-0162-01). These capacitors have shown good reliability even at maximum specified voltage. They are distinguishable from their 283-0162-00 counterparts by their blue color.

Modification 43875 calls for the part number of C565, C580 and C581 to change

(ARTICLE CONTINUED ON THE NEXT PAGE)

603A, 604A HIGH VOLTAGE CAPACITOR MODIFICATION 43875 (cont.)

from the 283-0162-00 to the 283-0162-01 component. This change rolls the high voltage board part number from 670-1813-02 to -04. In addition, the 050-1035-01 parts replacement kit changes to 050-1035-02.

The 283-0162-01 capacitors should be installed into all 603A/604A monitors whenever convenient.

W² Issue 11-22

1470/1474 BURST AMPLITUDE ADJUSTMENT AND GEN LOCK FREQUENCY CHANGE

1470 Reference: Mod M44284 and
Instruction Manual P/N 070-2096-00

1474 Reference: Mod M44284 and
Instruction Manual P/N 070-2097-00

To allow the black burst adjustment (sub-carrier amplitude, R230) to be made more to the center of R230's rotation, R229 can be changed from the present 11.0K resistor to a 12.7K 1% resistor, 321-0299-00.

To assure that the subcarrier frequency remains constant when the front panel SUB-CARRIER switch is exercised in the internal mode with no Gen Lock signal applied to the rear panel, a 220pf capacitor (C237) can be added to the sync board as shown in the following diagrams.

(ARTICLE CONTINUED ON THE NEXT PAGE)

PARTS LOCATION GRID
SYNC GENERATOR ASSEMBLIES 670-4553-03
AND 670-4553-04 CHANGING TO 670-4553-05 AND 670-4553-06 RESPECTIVELY

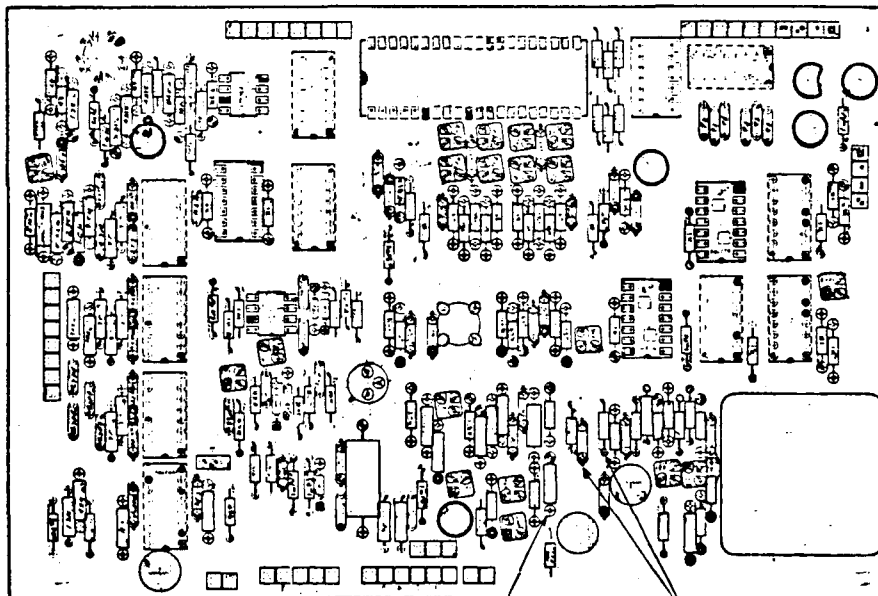

CHANGE R229 FROM
321-0293-00 (11.0K, 1%)
TO 321-0299-00 (12.7K, 1%)

ADD C237 283-0108-00
(220pf, 10%) FROM
LEAD OF C229 TO LEAD
OF R237

2213, SWEEP START ABERRATION REDUCED

Reference: 2213, S/N B010100 -
B012250
PICN #35

To reduce an aberration located approximately 100 nseconds from the start of the trace, three parts values are changed. The "glitch" is most noticeable when in Channel 2 mode with AC coupling. Change the following parts to these new values:

A11R645 6.8K P/N 315-0682-00
A11R646 10K P/N 315-0103-00
A11W635 1K (R556) P/N 315-0102-00
(Wire strap replaced by resistor)

W² Issue 11-19

2215, DTP MINIMUM SETTING

The DTP dial, R658, should read 0.4 at the minimum delay setting. Use this setting when replacing or readjusting the DTP dial.

W² Issue 11-21

2215, REDUCED TRACE NOISE IN CHOP MODE

Reference: 2215, S/N B010100-
B012000
PICN #34

To reduce Z Axis overshoot which causes chop noise and trace blooming at high intensity levels, A10R854 is changed to an 18 Ω resistor, P/N 315-0180-00. The original 27 Ω resistor was changed to a wire strap, W854 in most units by Manufacturing. For best performance the 18 Ω value should be used.

W² Issue 11-22

2215, 50 KH_Z B TRIGGER OPERATION

Reference: 2215, S/N B010100-
B012000
PICN #34

To ensure that the B triggers will meet

the minimum signal amplitude specification at 50KH_Z, zener diode A13VR584 was changed at approximately serial number B012000 to a tighter tolerance part, P/N 152-0662-00. Any 2215 with marginal B triggers with 0.4 divisions of signal should replace VR584 with this new part.

W² Issue 11-22

4016-1, GMA125 CRT; BONDED GLASS
IMPLOSION SHIELD

Reference:
4016-1 Manual, 070-2661-00
GMA125 Manual, 070-2618-00
Modification M39234

Recently all 25 inch CRT products have been modified to replace the polycarbonate implosion shield. The reason for this change is to eliminate distorted light reflections from the CRT face.

To accomplish this, a glass shield has been bonded onto the face of the CRT's in place of the polycarbonate shield.

With the additional thickness of the bonded glass shield, the CRT had to be moved back 3/8 of an inch to the rear causing the CRT JEDEC headers to be very close to the mu-metal shield wall. This could cause an electrical shorting problem unless additional space and insulation are provided. Therefore, the mu-metal shield was modified to add dimples to allow for new insulator heads that were designed to insulate the JEDEC headers.

Due to the contacting surface of the Rimband being covered with tape and epoxy as a result of bonding on the glass implosion shield, the present hardcopy filter ground clips were not functional. Also because of a redesign of the corner brackets, the brackets would not permit the ground clips to be located as before. As a result the ground clips were redesigned and are now mounted under the corner brack-

(ARTICLE CONTINUED ON THE NEXT PAGE)

4016-1, GMA125 CRT; BONDED GLASS IMPLOSION SHIELD (cont.)

ets in each corner. This arrangement is not obscured and permits easy assembly of the new ground clips.

Inner Filter Brackets previously had corner tabs which caused undue stress to crack the corners of the Light Fil-

ter. These brackets were designed to eliminate the tabs.

Outer Filter Brackets remain the same except for the type of foam tape being applied to the tabs. This same foam tape is also being placed on the glass implosion shield in the same positions as the tape on the Outer Filter Bracket so as to line up and better cushion the Light Filter.

Serial Number Breaks and Replacement Part Numbers

<u>Instrument</u>	<u>Starting S/N</u>	<u>For Replacements Use</u>	
		<u>Before Starting S/N</u>	<u>After Starting S/N</u>
4016-1	B040780	050-1331-12	154-0807-02
GMA125	B030396	050-1331-12	154-0807-02
GMA125 Opt 30	B030396	050-1331-13	154-0808-02
MEG121 Opt 36	B010102	050-1331-12	154-0807-02
M121F36	B010102	050-1331-12	154-0807-02

One exception to the above: If a product below the Starting Serial Number already has a CRT with the glass implosion shield then replace it with the appropriate 154 number.

Mechanical Parts List (MPL)

The manuals will be updated. In the meantime, please see the attached exploded views.

Exploded Views

The attached exploded views show both

the old and the new versions. Note the part numbers and part names. Also note the placement of parts, especially the rubber cushions for the Light Filter. Notice that the brackets have a long and short edge. Be sure to orient them correctly when installing a new CRT module. The long edges should be in a horizontal direction.

(ARTICLE CONTINUED ON THE NEXT PAGE)

4016-1, GMA125 CRT; BONDED GLASS

IMPLOSION SHIELD (continued)

EXPLODED VIEW OF OLD 154-0807-01 & 154-0808-01

CRT MODULAR

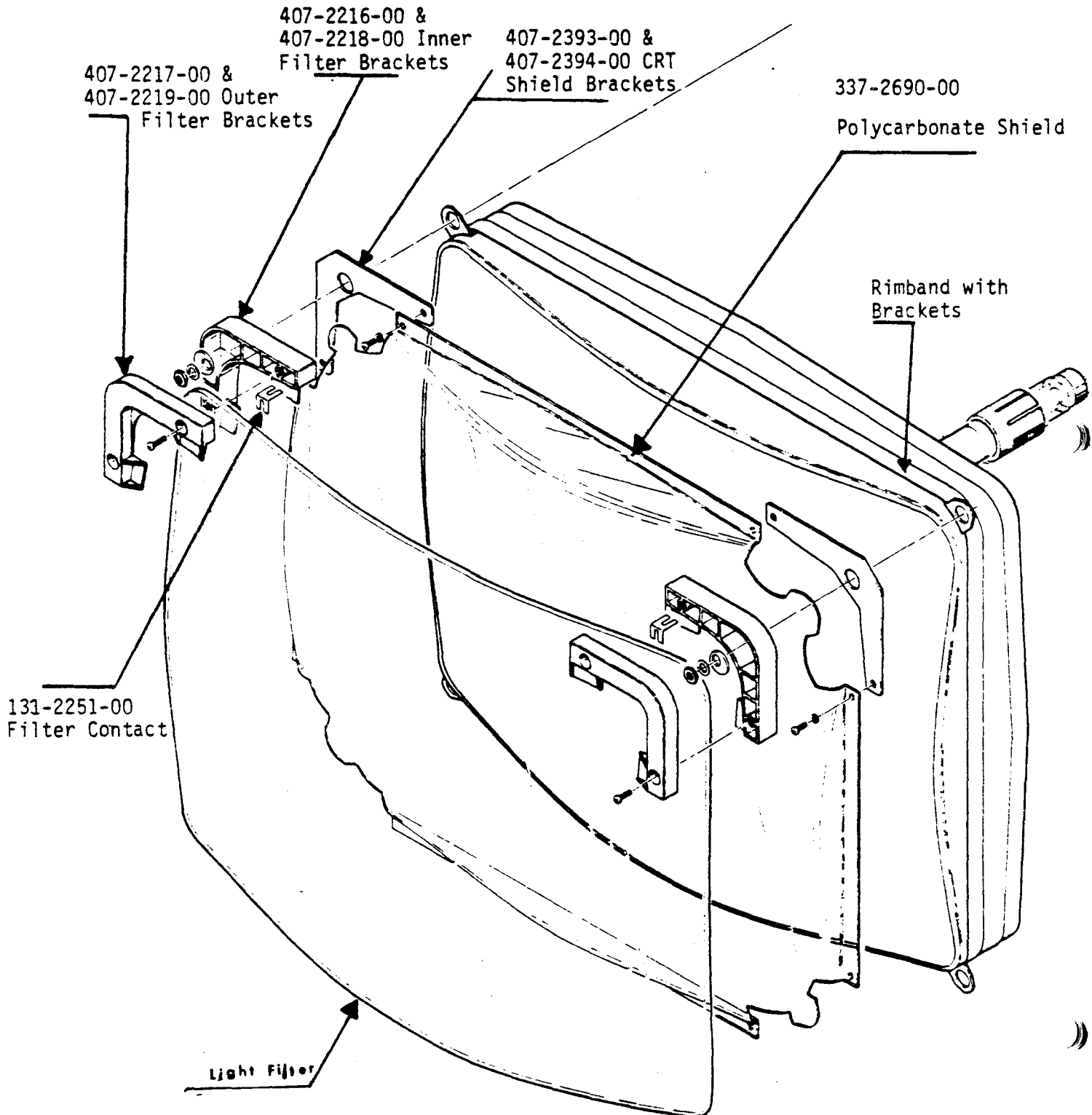

4016-1, GMA125 CRT; BONDED GLASS

IMPLOSION SHIELD (continued)

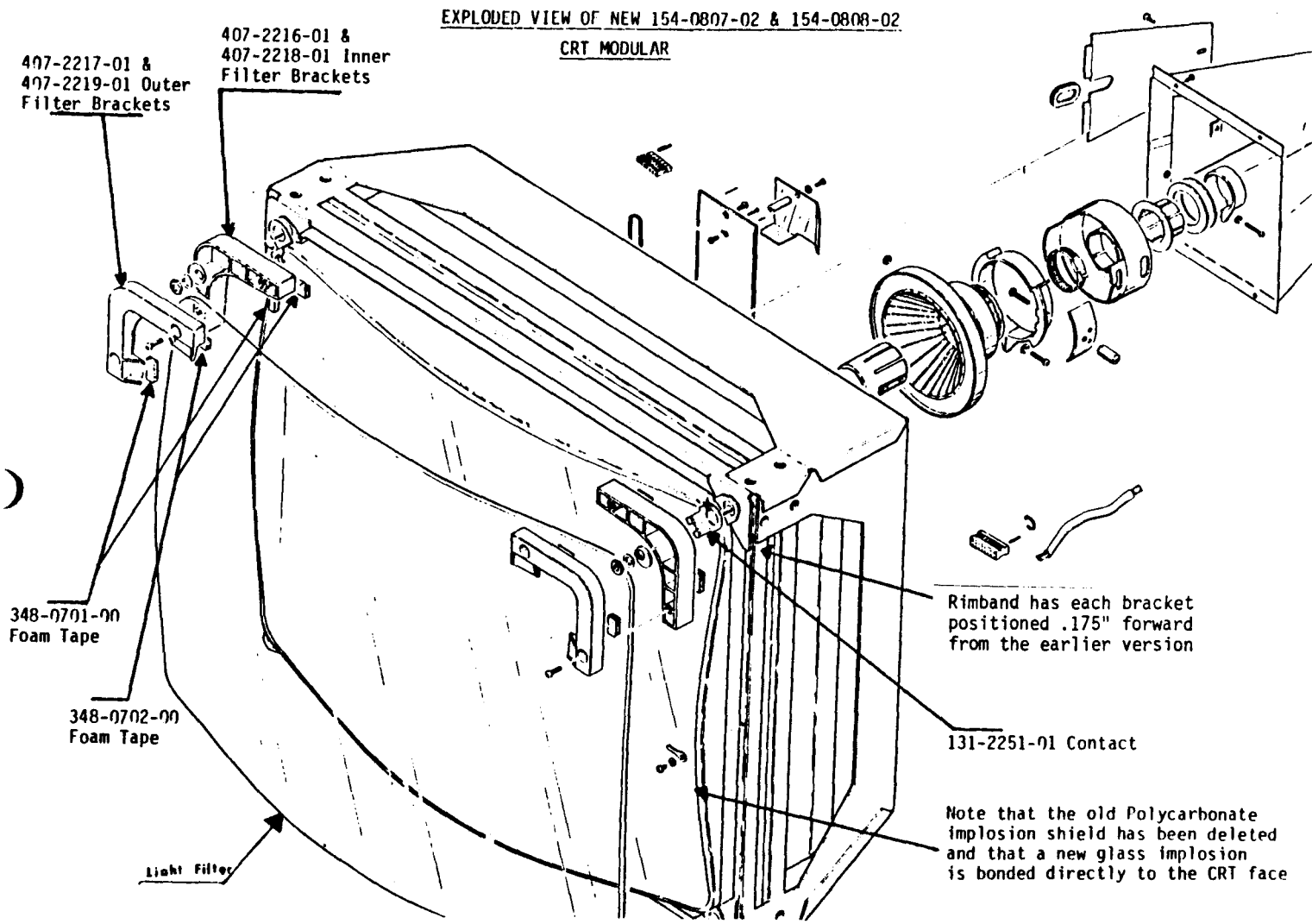

W² Issue 11-19

4611/4054: GRAPHIC SYSTEM HANGS WHEN COPIER IS TURNED OFF

The 4054 will hang busy when connected to a 4611 that is powered down. The problem is fixed by a mod to the 4611 DVST Interface Board, P/N 670-5756-00. All 4611s with S/N B010765 and above have this mod installed.

Installation instructions:

- Disconnect power and remove the DVST Interface board from the unit.
- Locate U255 and R256 just above it.
- Lift the left end of R256.
- Solder in a diode (P/N 152-0141-02) cathode down, in series with R256. See illustration.

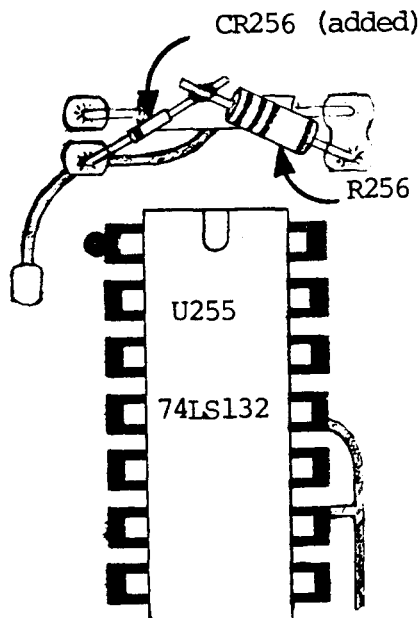

The part number suffix of the board rolls to 670-5756-01.

W² Issue 11-22

4611/12: TROUBLESHOOTING THERMAL FUSE FAILURE

The thermal fuse is a safety device. It should not fail unless there is a circuit failure on the Power Supply Board -- such as a shorted solid state

relay. However, some Service personnel have had to replace the fuse (a tedious job) with no failure evident -- except the fuse. Here is why:

1. If you replace the Power Supply Board or the fuser, the fuser temperature must be checked and adjusted if indicated. Use the Service Manual procedure, Section 3, "Adjustments", page 3-22. Differences between Power Supply Boards and fusers may result in a failed thermal fuse unless the calibration is done at first warmup (or preset R170 just CCW of midrange before power up).
2. Do not adjust R170 on the Power Supply Board without proper equipment. A DM501 with temperature probe is required; and be certain that the probe has been calibrated to the DM501.
3. Only Tektronix toner, part number 006-2990-00, may be used. The fusing temperature of this toner is matched to the calibration specification.
4. Look for wrinkles in the paper (they are easier to see on a solid black image). They indicate that the fuser temperature is too high.
5. If steps 1-4 above still do not keep the thermal fuse from blowing, the fuser itself may be at fault. There may be voids (bubbles) in the potting compound around the thermal resistor which inhibit heat transfer to the resistor. The result is overshoot of the fuser temperature during warmup, which can blow the thermal fuse.

W² Issue 11-22

7L5 DIGITAL STORAGE IMPROVEMENT KIT
(P/N 040-0872-02)

Serial Numbers: B010100 to B069999

An 040-0872-02 update kit has been set-up to replace the 040-0872-00 update kit. This modification kit contains parts and instructions to install a new Digital Storage circuit board (A4700, 670-5671-02). The new board replaces both the Digital Averaging (A4000, 670-3929-00) and Digital Storage (A4500, 670-3928-04) circuit boards. Increased reliability and the added feature of the B-(SAVE A) function, are provided by the new digital storage board.

W² Issue 11-19

7L5 U4702 REPLACEMENT KIT (050-1500-00)

Serial Numbers: B070000 to B092499

An 050-1500-00 parts replacement kit has been set-up to replace U4702. U4702, P/N 156-0570-00, and several other components are required to eliminate the need to select U4702 for proper operation of the "B save A" function.

W² Issue 11-19

067-0916-00 VIDEO AMPLITUDE CALIBRATOR
(VAC) & 067-1011-00 DIGITAL SWEEP
GENERATOR

Over the past several months I have received several inquiries pertaining to color signals, their specs, and how two new test fixtures, the 067-0916-00 VAC and the 067-1011-00 Digital Sweeper, fit into the picture. This article is intended to touch upon several of these points, and also to stand as the "reference article" for several new changes that will be published in the WIZARD'S WORKSHOP as they become finalized. The changes are mostly in the form of calibration procedure changes, and will be addressed separately.

Some Background--

Several years ago, there were a few interesting developments in electronics occurring almost simultaneously. In the early '60's, color television was a coming technology and transistors were making faint inroads into the limited areas of this science. With all of its collective wisdom, the FCC (and several industry leaders) decided that standardization of signals may indeed prove beneficial. One of several fallouts of this process was the "EIA Standard for Encoded Color Bar Signals", RS-189, a portion of which is shown in Figure 1.

This new signal standard provided not only luminance, chrominance and color phase information (the color bars themselves), but also quadrature information (the -I and Q signals). Of particular note here are the accuracies prescribed in this early document. Referring to Figure 1, one notices only nominal values listed for the various chrominance and luminance figures, and Note 5 gives tolerances of 2.5 IRE in amplitudes and 2.5° in phase (roughly 1.8% and .7% respectively). These figures were probably arrived at with due regard to the transmitter/receiver systems capabilities of the era.

Early in the '70's, Tektronix, using some of the recent advances in semiconductor technology, released the first of a series of generators, the 140, designed to provide high quality, stable test signals for the various world systems. The 140, 144, and 146 Test Signal generators were all designed for NTSC systems, and conformed to RS-189 as of their date of manufacture.

NOTES:

1. Waveform monitor measurements are made using a standard IRE scale.
2. A-Amplitude tolerance of all luminance values at origination point shall be ± 1 IRE scale unit of calculated value given in table following.

B-Peak-to-peak amplitude tolerances of

(ARTICLE CONTINUED ON THE NEXT PAGE)

067-0916-00 VIDEO AMPLITUDE CALIBRATOR (VAC) & 067-1011-00 DIGITAL SWEEP GENERATOR (cont.)

all subcarrier values at origination point shall be ± 1 IRE scale unit with respect to the calculated values given in table following. (See also Note 6.)

C-Phase tolerance of color subcarrier, measured relative to color sync burst = $\pm 1^\circ$ of calculated value given in table following.

Note: The above tolerances do not include tolerances involved in the measurement process.

3. Calculated and nominal values of luminance and P-P chrominance amplitudes for 100% saturated color bars of 75% amplitude with 7.5% setup are as follows (chrominance and luminance in IRE units). These values are calculated from the equations given in FCC Rules, §73.682(20).

(ARTICLE CONTINUED ON THE NEXT PAGE)

FIGURE 1
RS-189

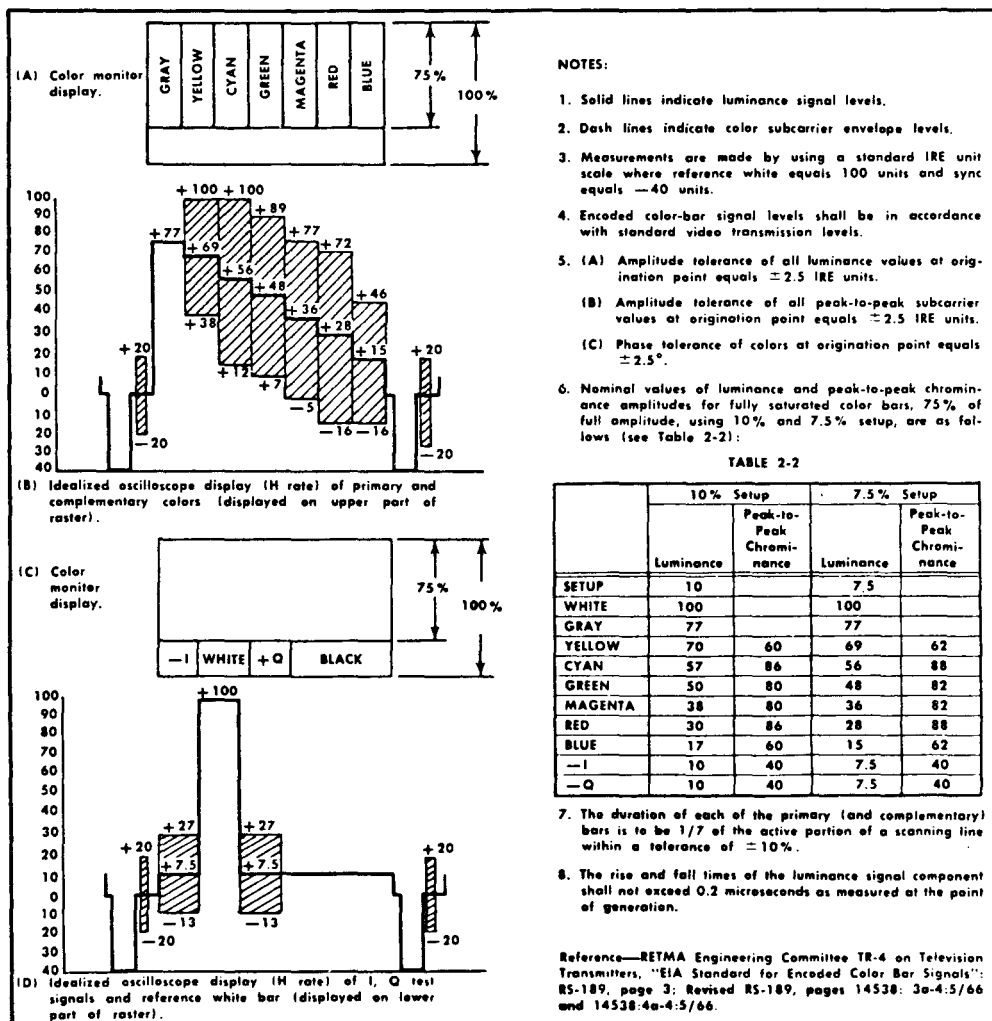

Fig. 1 Illustrations with notes showing the characteristics of a split field color bar signal using a 7.5% setup. Table 2-2 compares the amplitude of the color bars for 10% and 7.5% setup.

067-0916-00 VIDEO AMPLITUDE CALIBRATOR
(VAC) & 067-1011-00 DIGITAL SWEEP
GENERATOR (cont.)

FIGURE 2

	LUMINANCE		CHROMA (P-P)		PHASE	
	Calc.	Nom.	Calc.	Nom.	Calc.	Nom.
Reference Black	7.50	7.5	ϕ	ϕ	—	—
Reference White	100.00	100.00	ϕ	ϕ	—	—
Gray	76.88	77.0	ϕ	ϕ	—	—
Yellow	69.24	69.0	62.19	62	167.1°	167°
Cyan	56.06	56.0	88.21	88	283.4°	283°
Green	48.43	48.0	82.37	82	240.8°	241°
Magenta	35.94	36.0	82.37	82	60.8°	61°
Red	28.31	28.0	88.21	88	103.4°	103°
Blue	15.13	15.0	62.19	62	347.1°	347°
-I	—	7.5	—	40	—	303°
+Q	—	7.5	—	40	—	33°

FIGURE 2A

- 1- $E_M = E_Y' + [E_Q' \sin(\omega t + 33^\circ) + E_I' \cos(\omega t + 33^\circ)]$
- 2- $E_Q' = 0.41(E_B' - E_Y') + 0.48(E_R' - E_Y')$
- 3- $E_I' = -0.27(E_B' - E_Y') + 0.74(E_R' - E_Y')$
- 4- $E_Y' = 0.30 E_R' + 0.59 E_G' + 0.11 E_B'$

The introduction of RS-189A in July of 1976 did not change the fundamentals of the color bar test signals used, however, in referring to Figure 2 and Note 2, one notices tolerances becoming increasingly tighter, the amplitudes spec'd to 1 IRE and phase to 1°. Some small changes in chroma phase occur as a result of increased accuracies and will be addressed later.

Of particular interest, however, is Note 3 of Figure 2. It refers to equations given in FCC Rules, 73.682(20). See Figure 2A. New generator lines introduced after 1976, in particular the TSG-7 and the 1900, will have their specifications for luminance and chrominance levels calculated from these equations and listed in millivolt levels, with the possible exception of some very early TSG-1 manuals. These old TSG-1 manuals may reflect values derived from the table in Figure 2. These

values contained some rounding error and should be dealt with accordingly. However, this does not mean that older 140 Series generators must be discarded and replaced. We now have the capability of adjusting to RS-189A quickly, easily and accurately.

Past calibration techniques that were considered to be sufficiently accurate will no longer be adequate. These consisted of various combinations of 529 or 1480 waveform monitors, 547/1A5 Oscilloscopes, Chopped Voltage references, filters, notches, multiturn potentiometers, and others. These had a multitude of drawbacks, including impedance mismatches, frequency response errors, conversion tables, equipment tolerances, long term accuracy and drift, and eventually repair/parts problems and lack of traceability. Errors in amplitude measurements with a

(ARTICLE CONTINUED ON THE NEXT PAGE)

067-0916-00 VIDEO AMPLITUDE CALIBRATOR (VAC) & 067-1011-00 DIGITAL SWEEP GENERATOR (cont.)

waveform monitor having a 46dB common mode rejection ratio, a 2% frequency response error and multichrominance amplitudes. These are outside even the specs of older instruments.

With recent introduction of the TSG-7, we have specified the use of a 1480 Mod W5F and 067-0916-00 for amplitude calibration. With these two units, worst case errors will be 0.1125% for luminance amplitudes and 0.7225% for chrominance amplitudes. With the availability of this new equipment, we will no longer specify the older calibration methods in new cal procedures (chopped voltage reference, 1A5, etc.). The new units will provide sufficient accuracy to exceed the instrument specifications and thereby exceed RS-189A accuracy requirements.

The 067-0916-00 is not limited to NTSC. It has levels for the four major world standards--at the touch of a button. In addition to preset levels for major color bar signals used, the VAC (067-0916-00) has a set of lever switches that allows selection of any voltage between 0 and 999.9mV for comparisons/adjustments at a 0.1mV increment and with an accuracy of 0.05%. The major features provided as presets are:

1. 4 Color Systems
 - a. NTSC
 - b. PAL
 - c. PAL-M
 - d. SECAM
2. Color Bar Luminance Levels
 - a. PAL as %
 - b. NTSC as IRE
3. Color Bar Chrominance Levels
4. Full/Reduced Amplitude Bars
5. Set-up
6. Chrominance R-Y and B-Y

Figure 3 gives an example hook-up to adjust a Waveform monitor's internal calibrator. Figure 4 gives an example hook-up to adjust luminance levels in a generator under test. Due to the presence of harmonics on the signal coming from a generator and their possible effects on the signal (Figure 5), an example hook-up in Figure 6 shows the insertion of a sub-carrier harmonic rejection filter in the signal path coming from the generator under test when making chrominance measurements. To allow for the insertion loss of this filter, a 0.6% attenuator is placed in the path of the VAC signal.

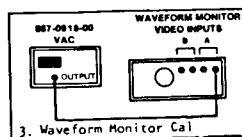

FIGURE 3

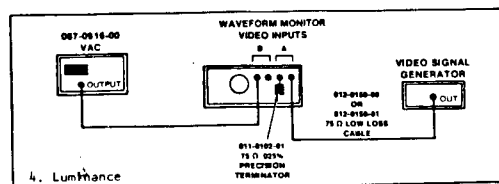

FIGURE 4

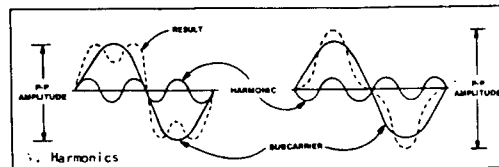

FIGURE 5

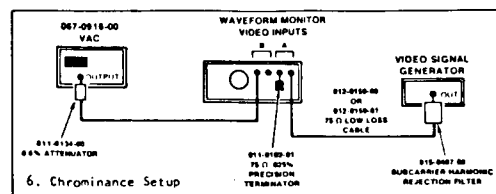

FIGURE 6

(ARTICLE CONTINUED ON THE NEXT PAGE)

067-0916-00 VIDEO AMPLITUDE CALIBRATOR (VAC) & 067-1011-00 DIGITAL SWEEP GENERATOR (cont.)

FIGURE 7

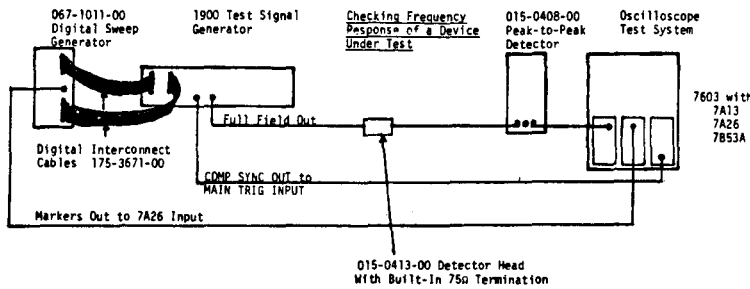
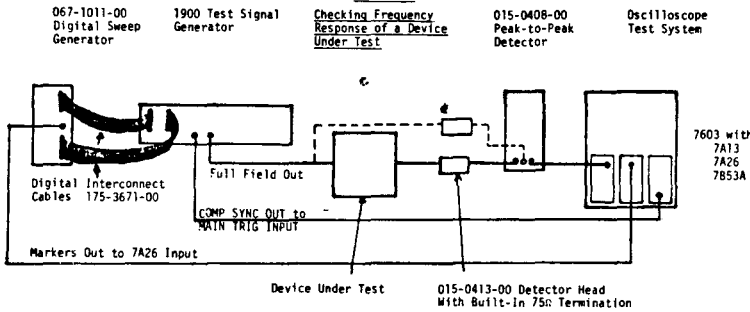

FIGURE 7A



Note the possible use of an additional 015-0413-00 Detector Head in a differential mode, allowing one to eliminate external signal anomalies.

FIGURE 7B

DETECTOR FREQUENCY RESPONSE (0.9VPP)

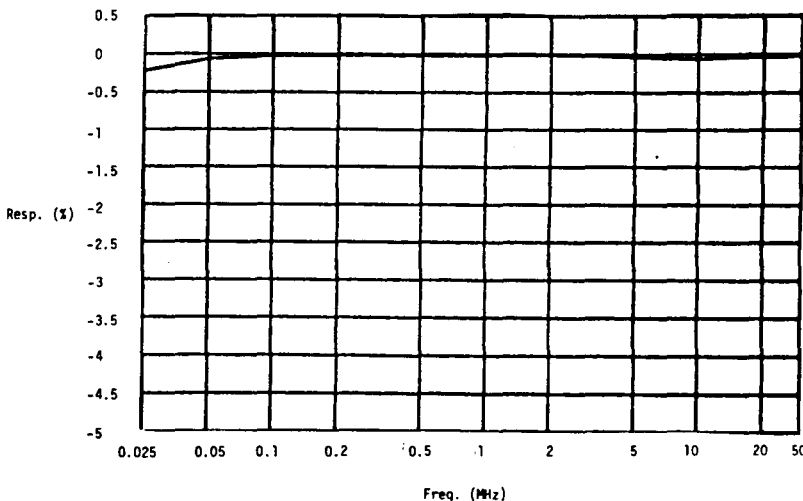

The 067-1011-00 (available Winter 1981) Digital Sweep Generator, when combined with a Tektronix 1900 Test Signal Generator, 015-0408-00 Peak-to-Peak Detector, and a 015-0413-00 Detector Head, will now provide the television services a precisely defined frequency response

standard heretofore virtually unachievable at reasonable costs. The 067-1011-00, when used in conjunction with a 1900, provides a digitally derived sinewave sweep throughout the video baseband (55.93kHz to 7.159MHz). Due to the digital signal generation used in the 1900, this will set chrominance to luminance gain on other signals (color bars, modulated pulse, etc.) accurately without further adjustments.

The 015-0408-00 (available Winter 1981) Peak-to-Peak Detector System is designed primarily for setting base band frequency response. The frequency response of a 1900 may be calibrated using an equipment set up similar to Figure 7. The 1900 can then be used as an accurate transfer standard in the calibration of waveform monitors, vectorscopes, and other devices.

The 015-0413-00 (available Winter 1981) Detector Head provides 75 ohm termination and is used with the Peak-to-Peak Detector right at the signal source, connecting to the Peak-to-Peak Detector with a length of low loss coaxial cable. The detector amplifier provides not only a high impedance load for the detector head, but also corrections for offset and gain errors not commonly found in other commercially available detectors. By using both inverting and non-inverting inputs, the detector can be used to make differential measurements from the input to the output of an instrument, thereby eliminating any errors in the source generator. Figure 7A illustrates a typical setup for frequency response measurement.

Figure 7B illustrates a typical frequency response curve of a sample detector head. These devices will not be serviceable by the user, will be verifiable by returning to the Tektronix Standards Lab through Factory Service, and will be shipped to the user with a reference response graph included. Frequency response measure-

(ARTICLE CONTINUED ON THE NEXT PAGE)

067-0916-00 VIDEO AMPLITUDE CALIBRATOR (VAC) & 067-1011-00 DIGITAL SWEEP GENERATOR (cont.)

ments will be specified for the following accuracies:

50kHz to 5MHz	.2%
100kHz to 5MHz	.1%

Application notes for the use of these devices are being formulated and are expected to give the customer detailed insight into what is now possible with regards to traceability and precision calibration.

Some More About Color--

Some of you have had questions as to the apparent change in color vector locations with reference to the 520A vector graticule. Using the mV levels specified by RS-189 and conformed to by the 140 Series generators, Figure 8 gives a breakdown of the color component levels and their resultant color phase relationships.

FIGURE 8

COLOR	RS-189 -- 140 Series						NOMINAL P-P CHROMA (IRE)
	CHROMA P-PmV	R - Y P-PmV	B - Y P-PmV	IRE* CALC.	PHASE ANGLE		
Yellow	445.09	95.6	434.7	62.34	167.6°	62	
Cyan	625.89	608.5	146.5	87.66	283.5°	88	
Green	588.32	512.9	288.2	82.40	240.7°	82	
Magenta	588.32	512.9	288.2	82.40	60.7°	82	
Red	625.89	608.5	146.5	87.66	103.5°	88	
Blue	445.09	95.6	434.7	62.34	347.6°	62	

*100 IRE = 714mV

Figure 8A gives the corresponding values for RS-189A. These are the numbers used in the TSG-1, TSG-7, 1900 and VAC.

FIGURE 8A

COLOR	RS-189A -- 1410 Series, 75% Amplitude, 7.5: Setup						NOMINAL P-P CHROMA (IRE)
	CHROMA P-PmV	R - Y P-PmV	B - Y P-PmV	IRE* CALC.	PHASE ANGLE		
Yellow	444.2	98.9	433.0	62.22	167.1°	62	
Cyan	630.1	612.9	146.3	88.25	283.4°	88	
Green	588.5	513.9	286.8	82.42	240.8°	82	
Magenta	588.5	513.9	286.8	82.42	60.8°	82	
Red	630.1	612.9	146.3	88.25	103.4°	88	
Blue	444.2	98.9	433.1	62.22	347.1°	62	

*100 IRE = 714mV

Figure 9 gives the difference in amplitude and degrees between the old and new standards.

FIGURE 9

COLOR	RS-189 vs RS-189A DIFFERENCES						NOMINAL P-P CHROMA (IRE)
	CHROMA P-PmV	R - Y P-PmV	B - Y P-PmV	IRE* CALC.	PHASE ANGLE		
Yellow	.89	3.3	1.6	.14	0.5°	0	
Cyan	4.21	4.4	.2	.59	0.14°	0	
Green	.18	1.0	1.4	.02	0.13°	0	
Magenta	.18	1.0	1.4	.02	0.13°	0	
Red	4.21	4.4	.2	.59	0.14°	0	
Blue	.89	3.3	1.6	.14	0.5°	0	

*100 IRE = 714mV

These numbers relate directly to a vector display such as the 520A. Figure 10, A-F, illustrates the calculated location of each point within its associated box in the pattern. Each color has both old and new vector values illustrated, along with the design dimensions of the actual CRT presentation in a 520A. (Figure 10 on following page.)

The 520A CRT graticule will probably not be changed due to the small differences involved, oftentimes less than a trace width.

Instruction manual changes are being implemented to take advantage of the VAC's capabilities, immediately, the 067-1011-00 when it becomes available. The TSG-7 presently specifies the VAC, and several other instruments have Instruction Manual changes in progress. These changes will be published in WIZARD'S WORKSHOP articles as they become available. The 1900 final Service Manual will specify an 067-1011-00.

New instruction manuals are going to specify the VAC and a 1480 Mod W5F (and an 067-1011-00 where appropriate). To continue to insure or increase our calibration accuracies, these are becoming "must have" items. They will provide not only the accuracy, but also reliability, repeatability, cost savings, flexibility, less down time for the bench, and are usable in traceability programs.

As new instruments achieve PSR (Product Shipment Release), information will be provided to allow the unit to be put on a traceability program, starting with the TSG-7 and the VAC. This information should include such things as "Before and After" data, NBS numbers, serial numbers of calibration units, dates, etc. Older instruments will have information sheets provided as time permits or where a definite need arises. Figure 11 illustrates the steps being (ARTICLE CONTINUED ON THE NEXT PAGE)

067-0916-00 VIDEO AMPLITUDE CALIBRATOR (VAC) & 067-1011-00 DIGITAL SWEEP GENERATOR (cont.)

established for traceability programs. Additional "paths" are expected and will be promulgated as appropriate.

The VAC is available now. It comes with the Subcarrier Harmonic Rejection Filter (015-0407-00), 0.6% attenuator (011-0134-00), and precision terminator (011-0102-01). The 067-1011-00 should be available in the autumn of 1981. It includes an 015-0413-00 Detector Head will also be orderable separately.

Other measurement/calibration needs are being addressed and acted upon as appropriate. The word will be out when they're available.

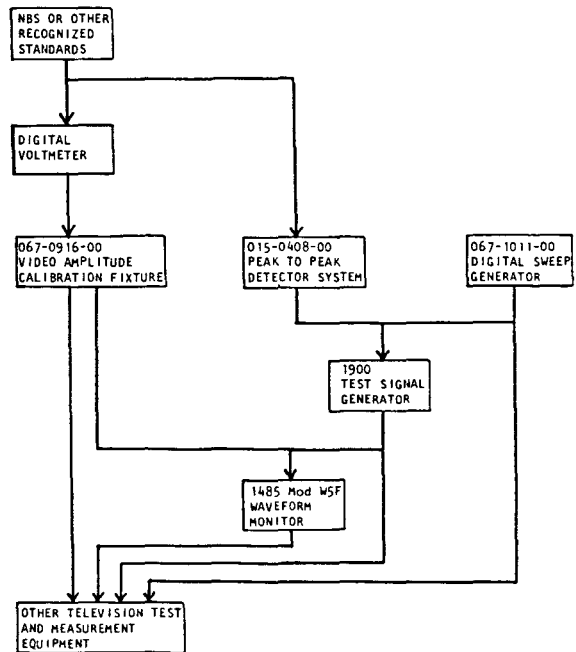

FIGURE 11: ESTABLISHING NBS TRACEABILITY OF TELEVISION SIGNAL AMPLITUDE AND FREQUENCY RESPONSE MEASUREMENTS

W² Issue 11-21

FIGURE 10

