

NOTES

PURPOSE

John Mulvey, 9-1-65

This calibration fixture is a mod kit for the Type 111 pulse generator that enables you to check or adjust the dot transient response of sampling scopes by alternately strobing DC level (0 volts) and the pulse from the Type 111.

067-0517-00 CALIBRATION FIXTURE

Two Triggers Per Pulse

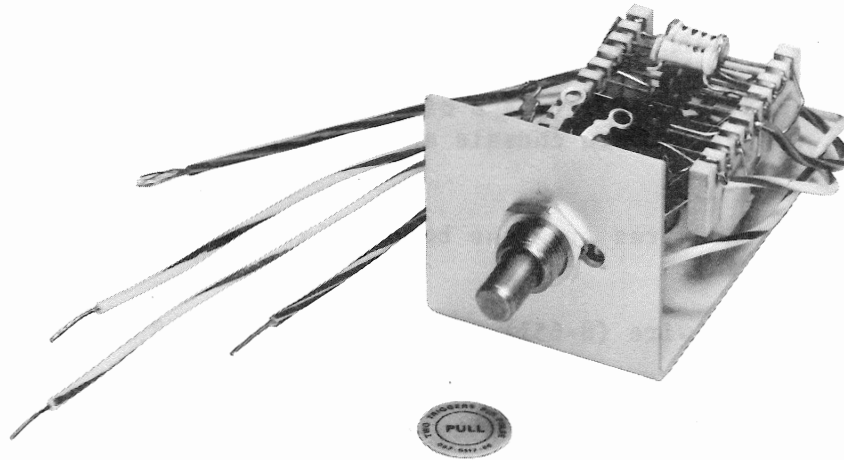

REF. NO.	PART NO.	SERIAL/MODEL NO.		QTY.	DESCRIPTION
		EFF.	DISC.		
	067-0517-00				<p>The 067-0517-00 is a modification kit for the Type 111 Pretrigger Pulse Generator that will give a signal output for every other pretrigger output. A two transistor multivibrator with an emitter-follower output that provides a signal to control the collector supply voltage for Q60. The multivibrator uses a trigger signal from T-40 to provide supply voltage for Q60 only for every other trigger signal. Thus, only one pulse occurs at the PULSE OUTPUT connector for every two pulses at the PRETRIGGER OUTPUT connector. This type of signal/trigger combination is useful for checking calibration and performance of sampling systems. The front-panel VARIABLE control has been replaced by a pull-type switch and pot combination with the knob labeled PULL TWO TRIGGERS PER PULSE.</p> <div style="border: 1px solid black; padding: 5px; width: fit-content; margin-left: auto;"> <p>DATA SHEET NO.</p> <p>062-0818-00</p> <p>MARCH 1967</p> </div>

Copyright © 1967,
Tektronix, Inc.
All Rights Reserved.

Specifications

Same as Type 111 except the Pulse Output Frequency is approx. 5 pps to 50 kc.

Installation Instructions

1. Remove VARIABLE knob and pot R53.
2. Mount Mod chassis in place of pot using lockwasher from original pot, no nut between chassis and sub-panel. Install knob and pot wires.
3. Connect the wires from the board as follows (cutt off excess wire length):
 - A. +6 volt wire (8-651) to 6 volt end of R623 or 6 volt end of D624.
 - B. -15 volt wire (0-150) to anode end of D625.
 - C. Trigger wire (9-1) to T-40 connection of T-40, D62 junction.
 - D. Remove R60 (470 ohm) from etched board.
 - E. Command wire (9-0) to T60 end, of holes vacated by R60.
4. Install transistors in Mod chassis and turn on Type 111.
5. Readjust AVALANCHE ADJUST and Max Delay (R51) and Min Delay (R54) per calibration procedure.

MECHANICAL PARTS LIST-067-0517-00

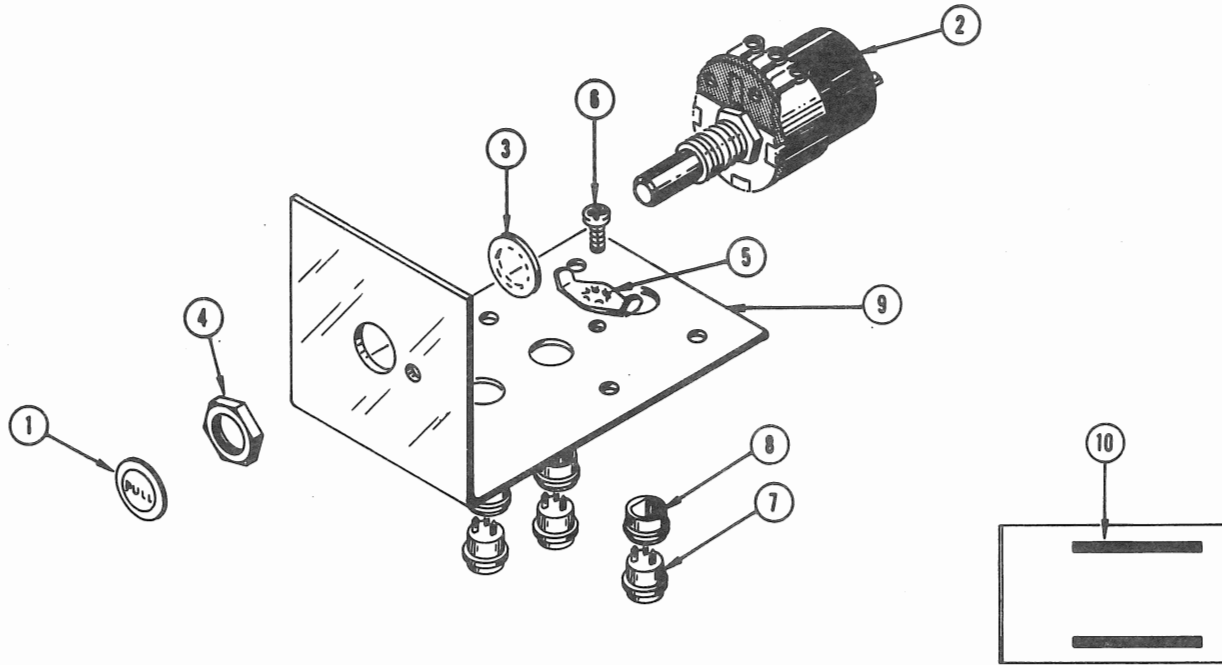

FIG. & INDEX NO.	TEKTRONIX PART NO.	SERIAL/MODEL EFF DISC	QTY	DESCRIPTION
1	E334-1004-00		1	TAG, identification
2	- - - - -		1	RESISTOR, variable
	- - - - -		-	- mounting hardware: (not included w/resistor)
3	210-0012-00		1	LOCKWASHER, internal, 3/8 ID x 1/2 inch OD
4	210-0413-00		1	NUT, hex., 3/8-32 x 1/2 inch
5	210-0204-00		1	LUG, solder, DE #6
	- - - - -		-	- mounting hardware: (not included w/lug)
6	213-0044-00		1	SCREW, thread forming, 5-32 x 3/16 inch, PHS
7	136-0181-00		3	SOCKET, transistor, 3 pin
	- - - - -		-	- mounting hardware for each:
	- - - - -		-	- (not included w/socket)
8	354-0234-00		1	RING, socket mounting
9	E407-0206-00		1	BRACKET
10	124-0157-00		2	STRIP, ceramic, 7/16 inch h, w/9 notches
	- - - - -		-	- each strip includes:
	355-0082-00		2	STUD, plastic
	- - - - -		-	- mounting hardware for each:
	- - - - -		-	- (not included w/strip)
	361-0008-00		2	SPACER, plastic, 1/4 inch long

ELECTRICAL PARTS LIST-067-0517-00

Values are fixed unless marked Variable

CKT. NO.	TEKTRONIX PART NO.	SERIAL/MODEL NO. EFF	DISC	DESCRIPTION
----------	-----------------------	-------------------------	------	-------------

Capacitors

Tolerance $\pm 20\%$ unless otherwise indicated.

C1	281-0523-00		100 pF	Cer 350 V
C2	281-0525-00		470 pF	Cer 500 V
C3	283-0028-00		0.0022 μ F	Cer 50 V

Diodes

D1	*152-0107-00		Silicon	Replaceable by 1N647
D2	*152-0107-00		Silicon	Replaceable by 1N647

Transistors

Q1	151-0164-00		Silicon	2N3702
Q2	151-0164-00		Silicon	2N3702
Q3	151-0164-00		Silicon	2N3702

Resistors

Resistors are fixed, composition, $\pm 10\%$ unless otherwise indicated.

R1	316-0332-00		3.3 k Ω	1/4 W	
R2	315-0243-00		24 k Ω	1/4 W	5%
R3	315-0243-00		24 k Ω	1/4 W	5%
R4	315-0203-00		20 k Ω	1/4 W	5%
R5	315-0203-00		20 k Ω	1/4 W	5%

CKT. NO.	TEKTRONIX PART NO.	SERIAL/MODEL NO. EFF DISC	DESCRIPTION
Resistors (cont)			
R6	315-0104-00	100 k Ω	1/4 W 5%
R7	315-0472-00	4.7 k Ω	1/4 W 5%
R8	301-0471-00 6713	470 k Ω	1/2 W 5%

SCHEMATIC

