



INSTRUCTION MANUAL - MODEL 5
GETTING MICROELECTRODE AMPLIFIER

(Serial # 700 up)

Getting Microelectrode Amplifier
417 Monroe St.
Iowa City, IA. 52240
Phone (319) 338-1646

Revised 2/82

CONTENTS

I. Introduction and specifications	1
II. Controls and their use	3
III. Maintenance and periodic adjustments	4
IV. Warranty and limited liability	7
V. Diagrams	8

I. Introduction

The MODEL 5 microelectrode amplifier comes fully adjusted and ready to use. Set-up entails connecting the 7-pin probe plug to the matching socket on the main chassis. Two shielded input cables are provided. One end consists of the input connector (gold) which matches the input socket on the probe (gold connector); the other end of the cable is left free so that you may connect to a variety of electrode holders of your design. The simplest way is to solder a silver silver-chlorided wire directly to the input cable.

CAUTION: If you choose to shorten the input cable, be sure the shield is not connected to ground, and that the shield is protected from contact with other wires or electrolytes. The shield is driven and provides part of the capacitance compensation network.

The unit is now ready for use. Please read this entire instruction manual before attempting to record with microelectrodes. Although this unit is made with high quality parts, it is not indestructible. Treat it with the proper care and it will give you years of trouble-free service.

Specifications

Input impedance	10^{10} ohms min. (typically 10^{11} ohms) // 2 pfd.
Voltage gain	x 10 fixed
Frequency response	Output frequency bandwidth has three selectable ranges: DC-10 Kc, DC-1 Kc, and DC-100 cps.
Input voltage range	+ 1 volt (can tolerate + 15 volts before permanent damage to the input stage occurs.)
Leakage current	adjustable to zero
Rise-time (10-90%)	40-50 microseconds (with 10 megohm source resistance and cap. comp. adjusted for no overshoot.)
Noise	40 microvolts RMS (200 microvolts peak-to-peak) with 10 megohm source resistance.

CAUTION: UNPLUG THE AMPLIFIER FROM THE 110 VOLT AC OUTLET BEFORE PROCEEDING.

The back cover is removed by taking out the two screws in back. Slide the back box along the power cord to expose the circuit board.

WHILE THE BACK COVER IS REMOVED, BE SURE NOT TO PLACE THE AMPLIFIER ON A CONDUCTING SURFACE OF ANY KIND. DO NOT TOUCH ANY OF THE WIRES OR COMPONENTS IN THE POWER SUPPLY SECTION. OF THESE COMPONENTS CARRY 110 VAC. MANY

Adjustments:

Section 1: Zero input amplifier (A-1). Ground the input on the probe and connect test point 1 (TP1) (see drawing 1) to an oscilloscope. Turn the AC power ON and allow the unit to warm up for several minutes. Adjust the trim potentiometer (T-1) in the probe until the voltage at TP1 is at ground. To gain access to T-1 potentiometer you will have to take out the four screws on the probe and remove the cover. Reassemble the probe cover when this adjustment is done.

Section 2: Zero STIM INPUT amplifier (A-5). Ground the input to the probe and be sure the current polarity switch is in the OFF position. Turn the STIM CANCEL control fully counterclockwise. Connect the X 10 amplifier output to the oscilloscope and turn the gain to 10 mV/div. Center the trace with the POSITION control. Slowly turn the STIM CANCEL control clockwise while observing the output voltage. If it shifts more than 10 mV adjust the trim pot. (T-5) to return the trace to its original position. Access to T-5 is through an access hole on the front panel just to the left of the current monitor output (CUR. MON.). This access is labelled "Z". Turn the STIM CANCEL fully clockwise and check for shifts in the output voltage. Adjust T-5 for minimal shift between fully counterclockwise and clockwise of the STIM CANCEL. Return the STIM CANCEL to fully counterclockwise.

Section 3: Gain adjustment: Connect a pulse generator to the probe input and apply a known voltage pulse less than 1 volt. Connect the X 10 output to the oscilloscope and adjust the gain trim potentiometer (T2) for exactly X 10 gain. T2 is located on the back of the chassis circuit board.

Section 4: Input impedance adjustment: With the pulse generator still connected to the probe input, also connect the pulse generator to the minus (-) input of a differential input oscilloscope. Connect the plus (+) input of the scope to test point 2 (TP2) (drawing 1) on the chassis circuit board. Adjust trim potentiometer T-3 for a null response; that is, no voltage shift during the voltage pulse. Turn up the gain on the oscilloscope so that a 1% difference in potential can be detected (e.g. if the input pulse is 100 mV, the gain should be at least 1 mV/div. on the scope).

Output single-ended, low impedance

Current injection Mode A: built-in adjustable source
 $\pm 0 - 10$ nA.

Mode B: externally applied voltage to current conversion.

Maximum current =

$\frac{5 \text{ volts}}{\text{electrode res.}}$ or 130 nA
 whichever occurs first. (See graph on page 9 for complete specification of current limits.)

Current monitor Built-in current monitor which measures the actual current through the electrode. Sensitivity 100 mV per nanoampere.

Stimulus cancel Built-in bridge circuit can compensate for electrodes up to 100 megohms. (Unit can be modified easily to handle electrode resistances up to 200 megs.)

Stimulus inputs Input resistance = 100 kilohms, maximum input voltage range ± 13 volts. Stimulus voltage to current conversion factor, 100 mV per nA.

Power 110 VAC, 0.1 amps. Built-in regulated ± 15 VDC power supply.

Ground Circuit ground and chassis ground may be isolated.

II. Controls and their use

The controls on the Model 5 are conveniently arranged so that those involved in recording are located to the left of the mid-line; those to the right are associated with current injection.

Recording Controls (left side):

POSITION: this control varies the DC level of the output. It is a 10-turn potentiometer which allows easy adjustment of the position even at high amplification. Clockwise makes the output more positive.

CAP. COMP.: This control provides for negative capacitance to cancel stray electrode and cable capacitance. It should be adjusted to give minimal (fastest) rise-time with no overshoot on a square voltage pulse to the input through the recording electrode. The adjustment depends upon the electrode resistance. Oscillation will occur if the CAP. COMP. is adjusted too high.

ELECTRODE CHECK: (EL. CK.) this button is used to measure electrode resistance. When depressed, a one (1) nano-ampere current is injected through the electrode. The change in output voltage is used to determine electrode resistance. The calibration is 1 megohm per 10 millivolts shift at the output. Be sure to fully depress the button.

CIRCUIT GROUND: the circuit ground (green binding post) of the Model 5 is isolated from the chassis ground (black binding post). For most uses the circuit ground should be connected to the chassis ground by connecting a wire between the two binding posts. Sometimes when using more than one Model 5 in the same bath the 60 cycle noise introduced by ground loops may be decreased by ungrounding one of the circuit grounds. The small black binding post on the probe is circuit ground.

OUTPUT FREQUENCY FILTER: (FILTER) located just above the X 10 amplifier output is a 3-position switch which selects the output frequency bandwidth. The selectable ranges are D.C. to 10 KC, 1 KC, or 100 C.P.S. When using the Model 5 in either the 1 KC or 100 C.P.S. positions, the "CAP. COMP." will not significantly affect the rise-time of the output as this is slowed by the output filter.

Current Injection: (right side controls)

STIMULUS CANCEL (STIM. CANCEL): This controls an internal bridge circuit which allows the IR voltage drop across the electrode to be subtracted from the output voltage during current injection. It cancels for internally generated as well as externally applied (stim. inputs) current injection. The maximum electrode resistance for which the cancellation can be used is 100 megohms.

INTERNAL CURRENT SOURCE: The Model 5 has an internal current source with switchable polarity and variable level. With the "HYP-OFF-DEP" switch in the "HYP" position, hyperpolarizing current of a magnitude selected by the "CURRENT LEVEL" control just above the polarity switch is injected through the electrode. Likewise, in the "DEP" position depolarizing current is injected. In the "OFF" position the internal current source is disabled; (the external stim. inputs are still operative). To prevent excess leakage current, the internal current source should remain in the "OFF" position when not actually in use. The maximum current capabilities of the internal current source are 0-10 nanoamps. Both the internal current source and externally applied stimuli through the "STIM INPUTS" can be monitored at the "CURRENT MONITOR" output. The "CURRENT MONITOR" output sensitivity is 100 mV per nA. This is a monitor of the current injected through the electrode.

STIM. INPUTS: Two inputs for externally applied stimulus voltages are provided. The current through the electrode is the sum of the currents from both external inputs plus the internal DC source. The voltage-to-current conversion factor for externally applied voltages is

1 nanoampere per 100 millivolts stimulus voltage.

The maximum allowable stimulus input voltage is ± 13 volts. Damage to the current injection network will result if the stim. input voltage exceeds ± 30 volts. Above ± 13 volts no increase in current injection occurs so there is no reason to ever exceed the lower voltage.

Other External Controls:

Two access holes are on the front panel. These are adjustments which control leakage current and zero level of the current injection circuit. Under normal circumstances they will not need adjustment (see maintenance).

III. Maintenance

Only one adjustment need be made periodically. About every 100 hrs. of use for the first 6 months, the leakage current should be checked and adjusted as outlined below. Due to component "aging" more extensive adjustment may be necessary. The entire adjustment procedure is outlined below. To adjust only the leakage current go directly to section 6. The sequence of adjustments is critical and should be followed exactly.

Equipment needed:

- 1 - small screwdriver
- 1 - 100 megohm resistor (a smaller value will do but will be less accurate)
- 1 - pulse generator (0-1 volt)
- 1 - differential input oscilloscope (1 mV per division sensitivity)

Section 5: Common mode on current monitor: With the pulse generator still applied to the probe input, connect the CURRENT MONITOR output to the oscilloscope and turn the gain to 1-5 mV/div. Adjust trim potentiometer T6 on the chassis circuit board for a null response on the CURRENT MONITOR output.

Disconnect the pulse generator.

Section 6: LEAKAGE CURRENT (I_G): Be sure the internal current source is in the OFF position and the STIM. INPUTS are disconnected from any external devices. Connect a 100 megohm resistor (a smaller value will do but the accuracy of this adjustment will be diminished) to the input on the probe and the other end to ground. With a short wire with clips on either end, short the 100 megohm resistor (connect the wire across the resistor). Connect the X 10 output to the scope and turn the gain to 10 mV/div. Center the trace with the POSITION control. Alternately ground and unground the input side of the 100 megohm resistor by removing the shorting wire. Any shift in the DC level of the output is due to leakage current. Adjust the I_G trim potentiometer (T4) on the left side of the chassis front panel for minimal DC shift. A voltage shift of less than 10 mV means a leakage current of less than 10^{-11} amps. Remove the 100 megohm resistor and ground the input.

Section 7: Current Monitor zero level: Ground the probe input and connect the CURRENT MONITOR output to the scope (gain 1-5 mV/div.). Be sure the internal current source is in the "OFF" position and the STIM. INPUTS are disconnected from any external devices. Adjust trim potentiometer T7 on the chassis circuit board so the CURRENT MONITOR output is at zero (ground) potential.

This completes the adjustment section. Leakage current can be adjusted at any time by following the instructions for Section 6.

BEFORE REASSEMBLING THE BACK COVER TURN THE AC POWER OFF AND UNPLUG THE AC POWER CORD.

Carefully slide the back cover box back along the power cord and install the two (2) mounting screws.

FUSE: If the pilot light does not light when the unit is plugged into the AC power and the power switch is in the "ON" position, the fuse may be blown.

UNPLUG THE AMPLIFIER FROM THE AC LINE VOLTAGE and remove the back cover.

The fuse is located in the power supply section on the back side of the circuit board.

Replace the fuse with a 1/8 amp. 110 VAC fuse (Size 3AG).

REASSEMBLE THE BACK COVER BEFORE PLUGGING THE UNIT INTO THE 110 VAC OUTLET.

IV. Warranty and Limits of Liability

Warranty: This warranty supercedes any other warranties either stated or implied. Getting Microelectrode Amplifier or its owners assume no responsibility for personal injury or property damage resulting from the purchase and use of the Model 5 microelectrode amplifier. The purchaser or user assumes all responsibility for proper supervision of the Model 5 use.

Getting Microelectrode Amplifier will replace or repair without charge the Model 5 due to faults in parts for a period of 90 days or workmanship for 1 year from the purchase date if such repair is not due to misuse or abuse. Determination of misuse or abuse is up to the discretion of Getting Microelectrode. Units should be sent postage prepaid to Getting Microelectrode with a short description of the problem.

DIAGRAM 1

MODEL 5 CHASSIS CIRCUIT BOARD

BACK VIEW

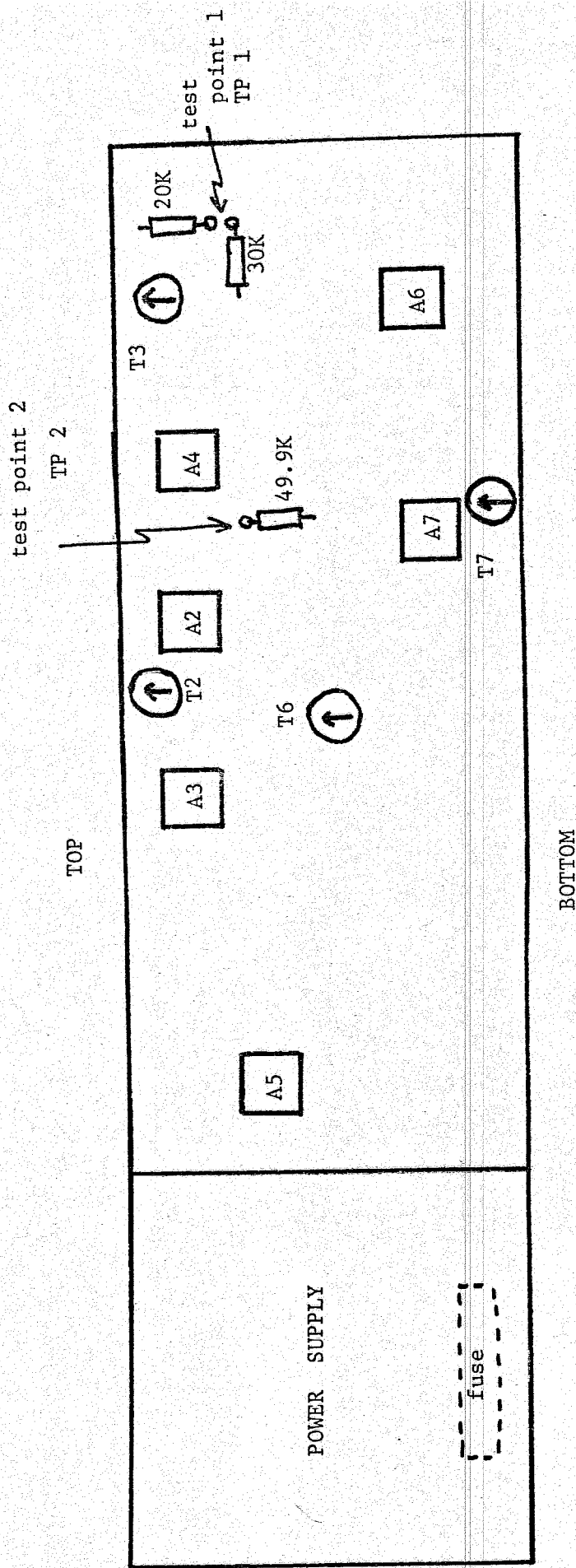

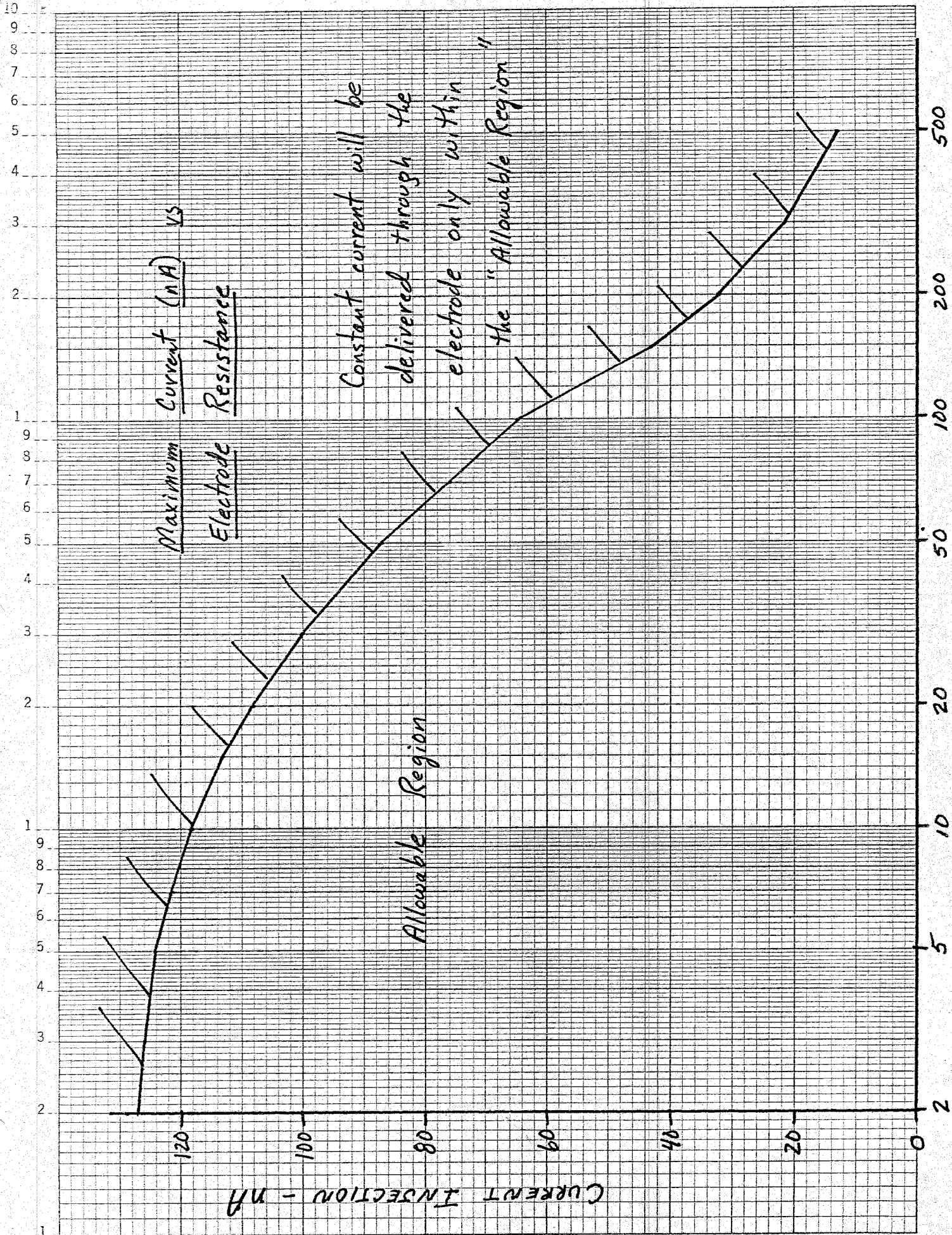

Allowable Region

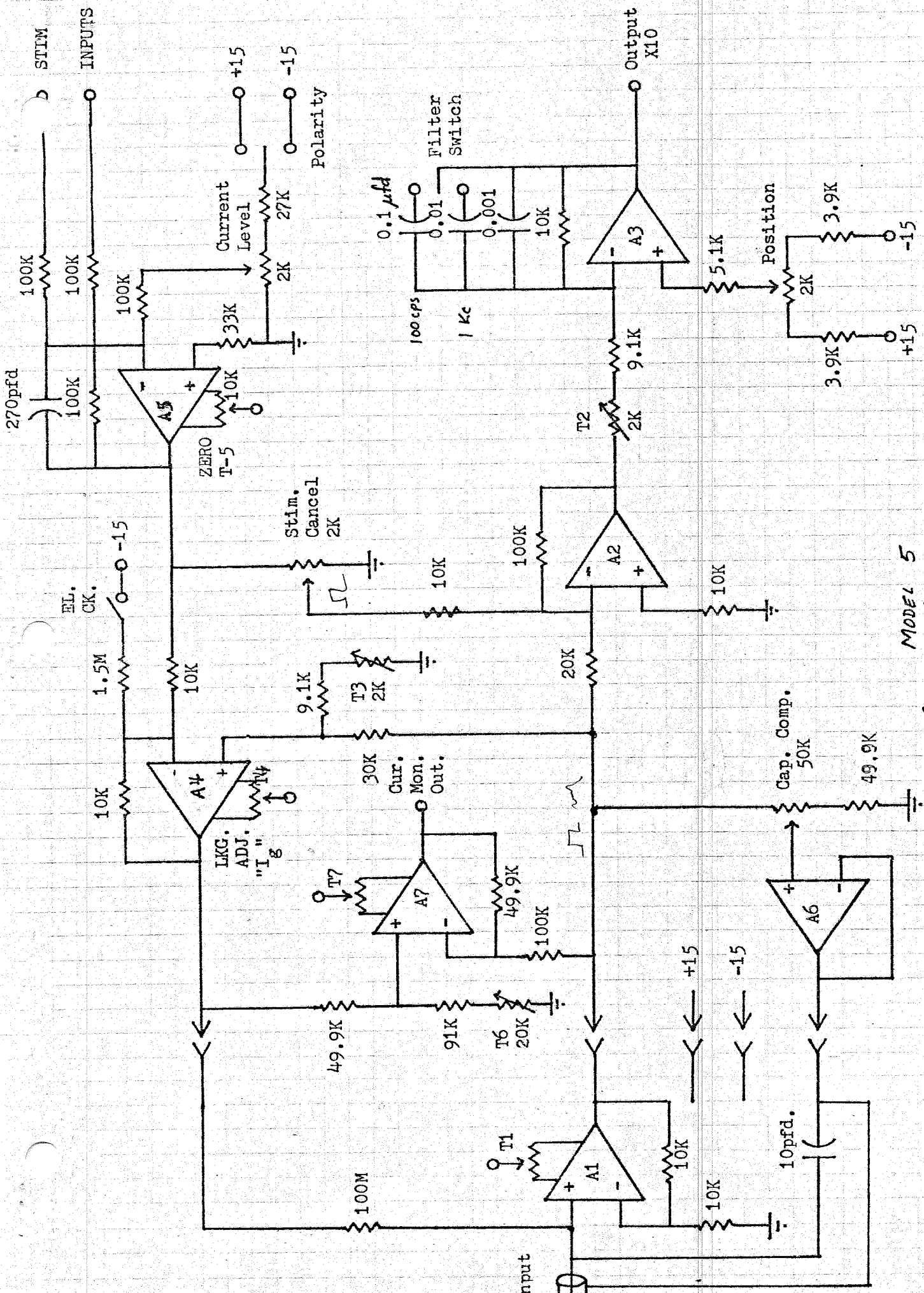

MODEL 5
 GETTING MICROELECTRODE
 AMPLIFIER
 417 MONROE ST.
 IOWA CITY, IA 52240

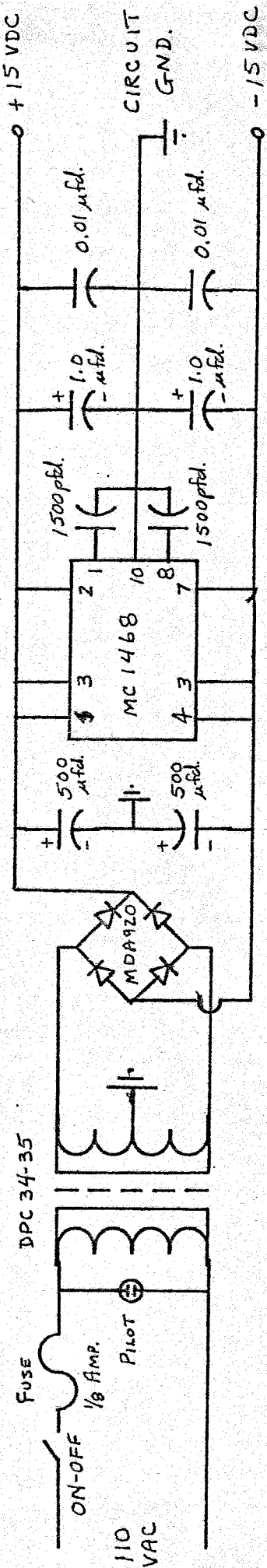

POWER SUPPLY ± 15 VDC
 MODEL 5

GETTING MICROELECTRODE AMPLIFIER
 417 MONROE ST.
 Iowa City, IA. 52240