

Camera Control Unit
C2400-60
INSTRUCTION MANUAL

HAMAMATSU 5110-246

Precautions

In order to use your equipment safely, please observe the precautions noted below.

- When unpacking the equipment, if any damage is observed, please return the equipment to HAMAMATSU without operating it.
- The power supply plug of this device should be connected to a 3-pin wall outlet with a protective grounding contact. If such an outlet is not available, always use the accessory GND cable to connect the equipment.
- If this device has been purchased by itself rather than as a set with the camera, it must be adjusted to match the camera being used. Please consult with HAMAMATSU or a HAMAMATSU sales representative to have your equipment adjusted.

1. Table of Contents

1. Table of Contents	1	8. Operation Method	
2. Unpacking the Equipment		· Contrast enhancement	14
· Making sure all the parts are included	2	· Shading corrector	16
3. Using Your Equipment Safely		· Video inverter	21
· Installing your equipment in a good location	3	· Video booster	22
· Precautions	3	· Auto gain control	23
4. Features	4	· Detail enhancement	24
5. Names and Functions of Parts		· Gray scale	25
· Front panel	6	· External synchronization	26
· Rear panel	8	9. External Control Command Specifications	
6. Connecting the Equipment		· Communications interface	27
· Power supply and GND cables	9	· Command format	28
· Connecting a CCD camera	10	· Camera responses to commands	29
· Connecting a video camera	11	· An outline of the commands	31
· Connecting a video monitor	12	· Command communications	33
7. Before Operating the Equipment	13	10. Maintenance	38
		11. Before Requesting Repair	39
		12. Specifications	40
		13. Warranty	42

2. Unpacking the Equipment

Making sure all the parts are included

- ① Camera Control Unit 1
- ② BNC-BNC cable 3m 1
- ③ GND cable 3m 1
- ④ Spare fuse 1A 1
- ⑤ AC outlet adapter (convertor plug) 1
- ⑥ Instruction manual 1

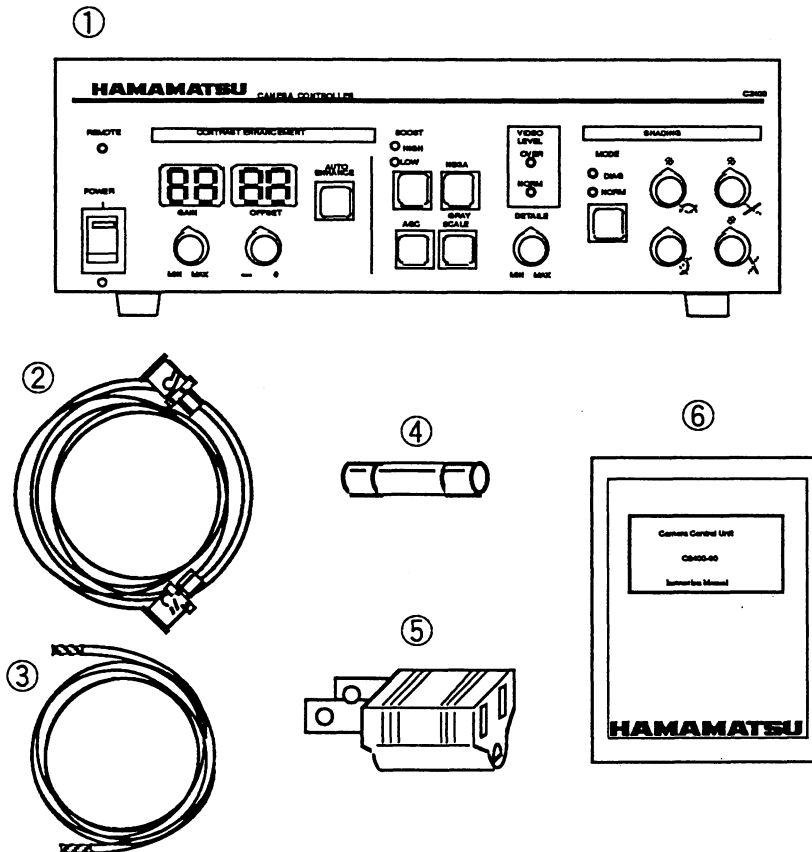

3. Using Your Equipment Safely

Installing your equipment in a good location

The following kinds of locations should be avoided:

- Places where the ambient temperature drops below 0°C or rises above 40°C
- In direct sunlight, or near a heating device
- Places where the humidity exceeds 90%, or where the equipment is exposed to water
- Places where the equipment is exposed to vibration
- Places where corrosive gases are present (such as chlorine or fluorine)
- Excessively dusty locations

Be careful not to cover the ventilation holes.

To keep the internal temperature from rising, never cover the equipment with a cloth or cover while it is in operation, and make sure it is installed in a location with good ventilation.

Avoid strong impact or shock.

Be careful not to drop the equipment or subject it to strong impact, as this damage it.

Precautions

About the power supply

- Make sure the equipment is used within the rated voltage range.
- Never set heavy objects on the power supply cord, or bend the cord sharply.
- When unplugging the power supply cable, hold the plug itself (not the cable), and unplug it gently, without pulling on it.
- If the equipment is not to be used for a long period of time, unplug the power supply cable from the wall outlet.

Do not disassemble the equipment.

Do not remove the top cover from the equipment. Touching anything inside this equipment is not only dangerous, but can also cause breakdowns and accidents.

If you notice any problems:

If no image is produced, or you notice an unusual noise, odor, or smoke coming from the equipment, immediately turn off the power supply switch and unplug the power supply cable from the wall outlet.

4. Features

The C2400-60 is a camera control unit which was developed for optical microscope observation in the biological and medical fields.

Using a CCD camera in the camera head enables stable images of outstanding quality to be obtained, with little after-image or pattern distortion. Numerous image enhancement functions such as contrast enhancement, contour enhancement, and shading correction are provided as standard features, enabling observation with detection capability surpassing that of the optical microscope. In addition, an RS-232C interface is provided, enabling external control using a computer or other equipment.

1. Contrast enhancement

With this feature, an offset level (threshold value) is set for the video signal, and signals above this level are enhanced. Thus, the contrast is heightened in images with low contrast, allowing the images to be viewed in finer detail. Using this feature in combination with a video inverter enables contrast enhancement of sections with a low intensity level as well.

An auto enhancement feature is also available which detects the intensity of the input light and adjusts the amplifier gain automatically, to maintain a uniform contrast level.

2. Shading corrector

When contrast enhancement is carried out, uneven brightness within the field of view appears becomes more conspicuous. Shading correction includes correction of the optics system so that contrast enhancement can be carried out effectively. Two types of correction, normal (horizontal/vertical) and diagonal, are provided.

3. Video booster

If dark sections have a low contrast level in contrast to bright sections, making them hard to see, the video booster can be used to enhance the contrast of the dark sections so that they are easier to see.

4. Video inverter

Depending on the object being monitored, there are some cases where the necessary information is concentrated in dark sections rather than distributed over both bright and dark areas. In this situation, the video inverter can be used to reverse the bright and dark sections of the image and further enhance the contrast, so that the dark sections of the image can be viewed in clear, sharp detail.

5. Detail enhancement

If the contour of the object being monitored is blurred and appears out of focus, detail enhancement can be used to enhance the contour, so that the image appears in finer detail.

6. Auto gain control

The intensity level of the input light is detected, and the amplifier gain is adjusted automatically to maintain a uniform video signal level.

7. Video level indicator

Two lamps, one red and one green, indicate whether or not the video level is appropriate. The brightness of the image can then be adjusted accordingly to make sure the optimum image is obtained.

8. Composite video input

A composite video signal is used as the video input signal standard. Because of this, it is not possible to select the type of camera to be used with the camera control unit.

9. External synchronization

Switching internal jumper connections allows control by means of external synchronization signals.

10. External control

An RS-232C interface allows functions such as contrast enhancement, shading correction, and the video booster to be carried out using a computer or other external equipment.

5 . Names and Functions of Parts

Front panel

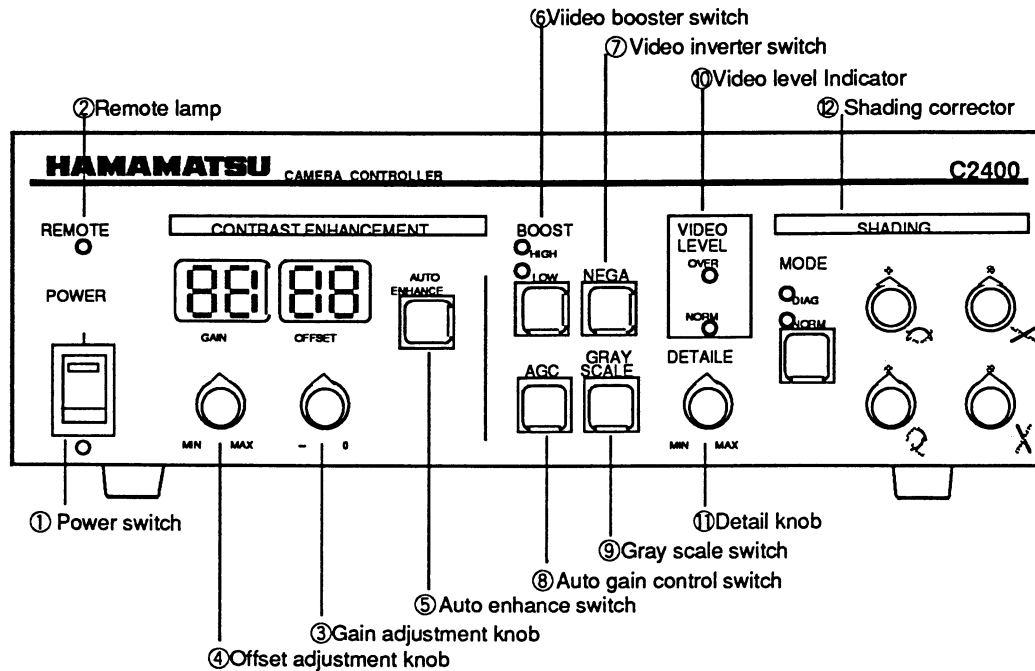

① Power switch (POWER)

This switch turns the power supply on and off. Setting the switch to the "I" side supplies power, so that the lamp lights, and setting it to the "O" side turns off the power supply.

② Remote lamp (REMOTE)

This lamp lights when control is initiated through an external computer.

③ Gain adjustment knob (GAIN)

This knob can be used to set the image gain consecutively to anywhere from 1 to 10 times. It can be used in combination with the Offset knob, to enhance the contrast of the image. Turning the knob to the right increases the value on the digital display from 0.0 to 10 in stepless increments.

④ Offset adjustment knob (OFFSET)

This knob is used to adjust the amount of offset in relation to the video signal. Turning it to the left increases the amount of offset shown on the digital display from 0.0 to 10 in stepless increments.

⑤ Auto enhance switch (AUTO ENHANCE)

Pressing this switch activates the automatic enhancement function and causes the switch to light. Pressing it once more stops the function.

⑥ Video booster switch (BOOST)

Pressing this switch activates the video booster and causes the switch to light. Each time the switch is pressed, the level changes in sequence from LOW to HIGH to OFF, with the corresponding lamp lighting simultaneously.

⑦ Video inverter switch (NEGA)

Pressing this switch reverses the video signal and causes the switch to light. Pressing it once more returns the image to its normal display.

⑧ Auto gain control switch (AGC)

Pressing this switch activates the automatic gain control function and causes the switch to light. Pressing it once more turns off the function.

⑨ Gray scale switch (GRAY SCALE)

Pressing this switch displays the gray scale at the right edge of the monitor and causes the switch to light. Pressing it once more turns off the display.

⑩ Video level indicator (VIDEO LEVEL)

This indicator displays the volume of incident light. The green lamp indicates that the amount of incident light is appropriate, while the red lamp indicates that there is too much incident light. If neither lamp is lighted, there is too little light, so the lens aperture or the brightness of the object should be adjusted to allow more light.

⑪ Detail knob (DETAIL)

This knob is used to adjust the amount by which the contour of the image is enhanced. Turning the knob in the clockwise direction increases the amount of enhancement.

⑫ Shading corrector (SHADING)

When this mode switch is pressed, the shading correction function is activated, and the switch lights. The knob is used to adjust the amount of shading correction. Each time the switch is pressed, the mode changes in sequence from NORMAL to DIAGONAL to OFF, and the corresponding lamp lights. When NORM is lighted, horizontal/vertical correction is carried out, and when DIAG is lighted, diagonal correction is carried out.

Rear Panel

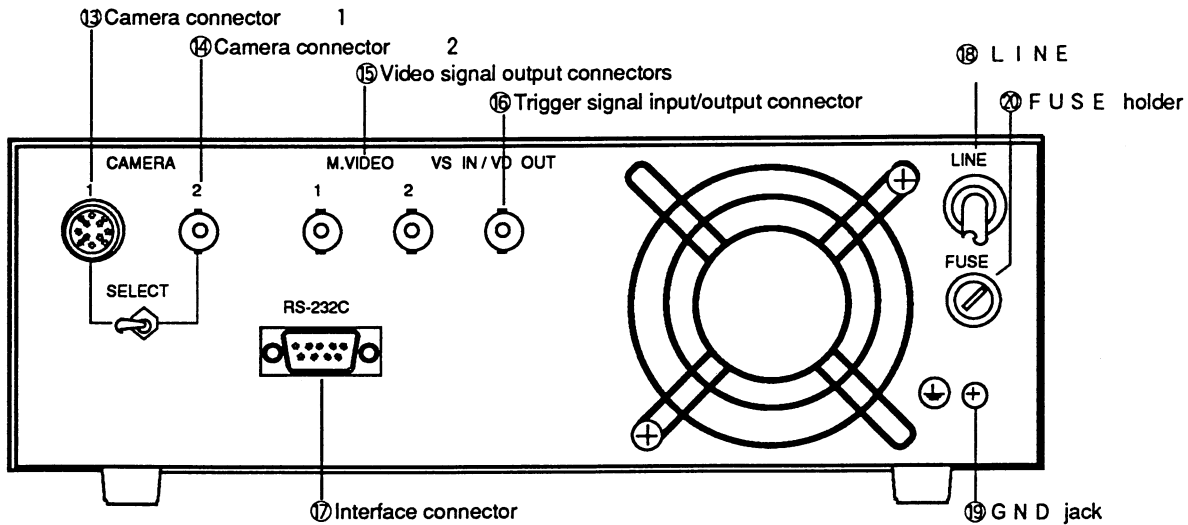

13 Camera connector 1 (CAMERA 1)

This connector is used to connect the camera control unit with the camera. The connector provided as standard is designed to connect the camera control unit to the CCD Camera C3077 made by HAMAMATSU. Camera 1 is selected by setting the selector switch to that position.

14 Camera connector 2 (CAMERA 2)

This is the composite video signal input jack for use with a television camera. It should be connected to the composite video output jack VIDEO OUT on a vidicon made by HAMAMATSU, or on an instrument such as another CCD camera. Camera 2 is selected by setting the selector switch to that position.

15 Video signal output connectors (M.VIDEO 1,2)

These are the composite video signal output jacks.

16 Trigger signal input/output connector (VS IN/VD OUT)

This is the I/O jack for external synchronization. When using internal synchronization, this serves as the VD signal (negative logic) output jack, and when using external synchronization, it serves as the SYNC signal (negative logic) or the VBS signal input jack. It is switched by means of an internal jumper.

17 Interface connector (RS-232C)

This connector enables an RS-232C interface to be connected.

18 LINE

This is the cable which supplies power to the camera control unit.

19 GND jack

This is the frame ground for the camera control unit. The equipment should be grounded to a nearby location using the GND cable provided as an accessory. If the equipment can be grounded using the power supply cable, it does not necessarily need to be grounded using this jack.

20 FUSE

This cuts off the power supply line in the event of excessive current.

6 . Connecting the Equipment

Power supply and GND cables

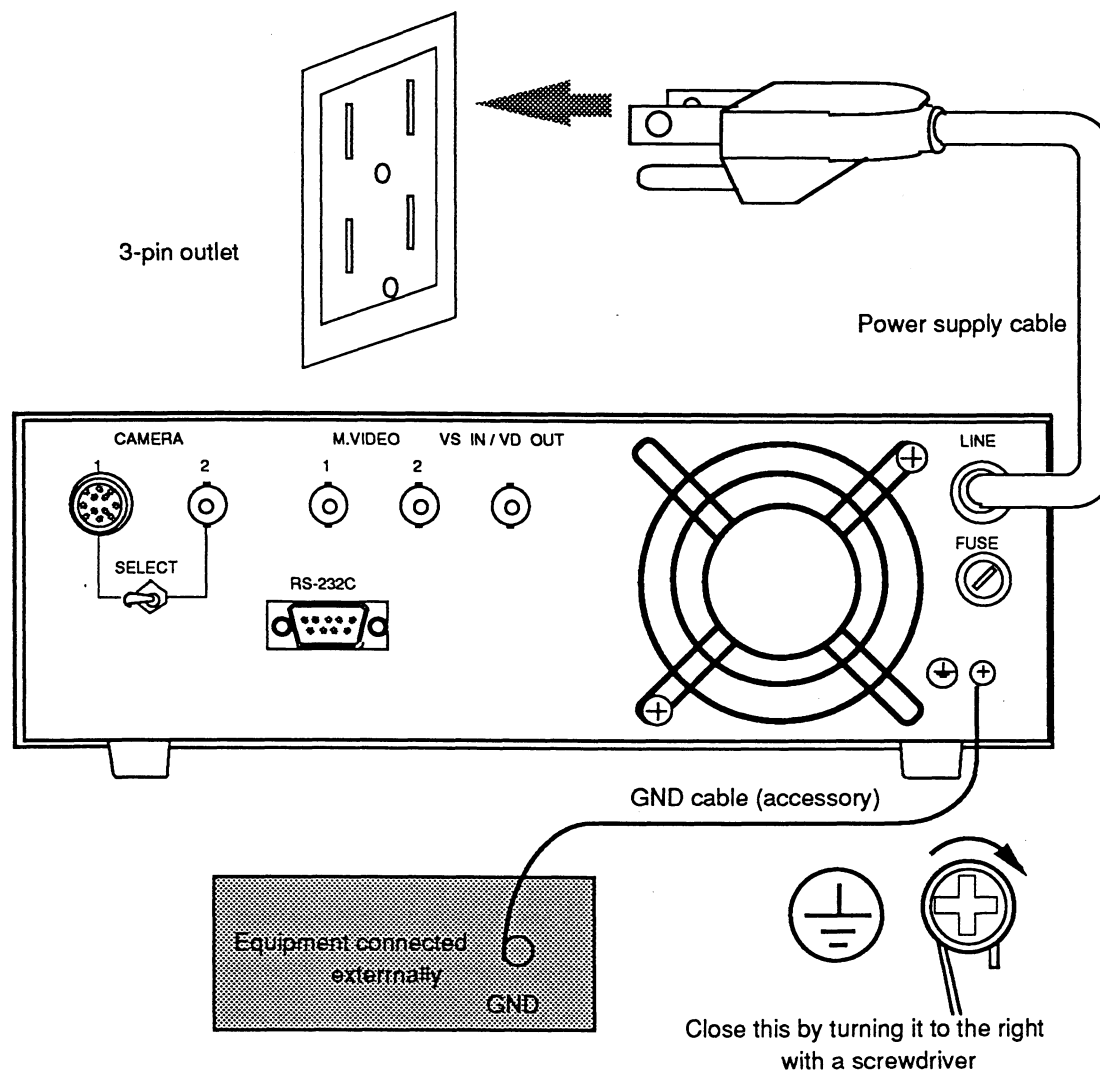

1.GND cable (accessory)

Any other equipment being used in combination with the camera control unit should also be grounded. It is especially important to ground any equipment connected to the camera control unit which has a pulsed motor and/or a thyristor. If the equipment is to be placed on a rack, connect it to the stand of the rack. If the 3-pin power supply cable is used for grounding, the equipment does not necessarily need to be grounded separately.

2.Power supply cable

This should be connected to a 3-pin wall outlet. If a 3-pin wall outlet is not available, use the adaptor plug provided as an accessory to connect the power supply.

CAUTION

Make sure the power supply switch is OFF.

Connecting a CCD camera

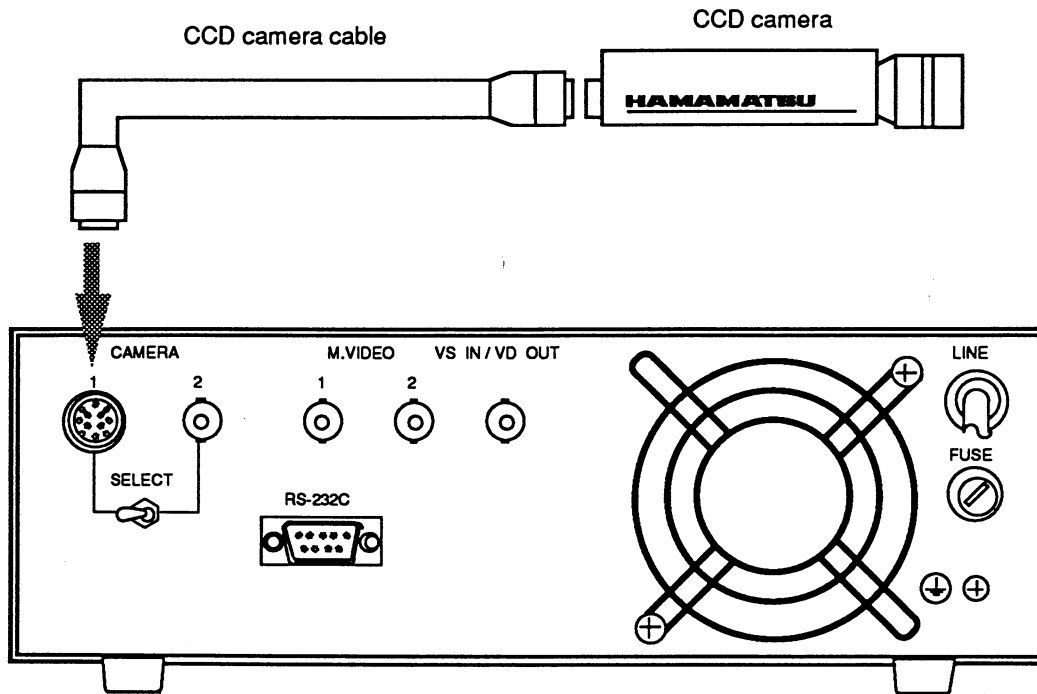

Using the CCD camera cable (sold separately), connect the CCD camera to the CAMERA 1 connector on the C2400-60. Connect the male connector on the camera cable to the female connector on the camera, and set the selector switch to the CAMERA 1 side. Each connector is provided with an insertion index, so line up the male and female connectors with the corresponding index and plug in the cable. When disconnecting the cable, grasp the cable by the ring on the connector and pull it free from the connector.

Connecting a video camera

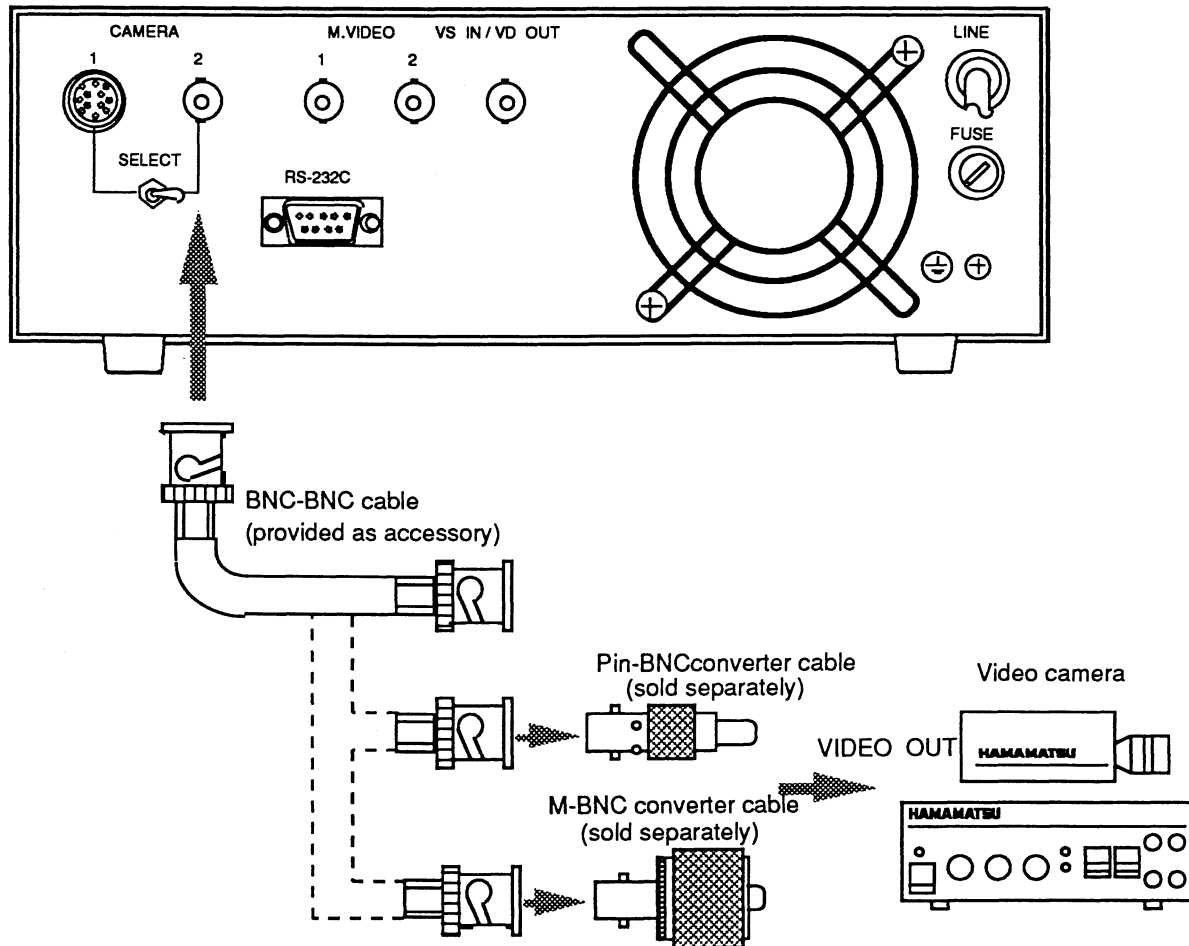

Using the BNC-BNC cable, connect the VIDEO OUT jack on the external equipment with the CAMERA 2 connector on the camera control unit, and set the selector switch to the CAMERA 2 side.

If the connector is not a BNC connector, use a Pin-BNC converter or an M-BNC converter to connect the BNC cable.

CAUTION

The CAMERA 2 connector has an internal terminus of 75 Ω . When connecting other equipment in series, be sure the 75 Ω terminus switch of the other equipment is turned off.

Connecting a video monitor

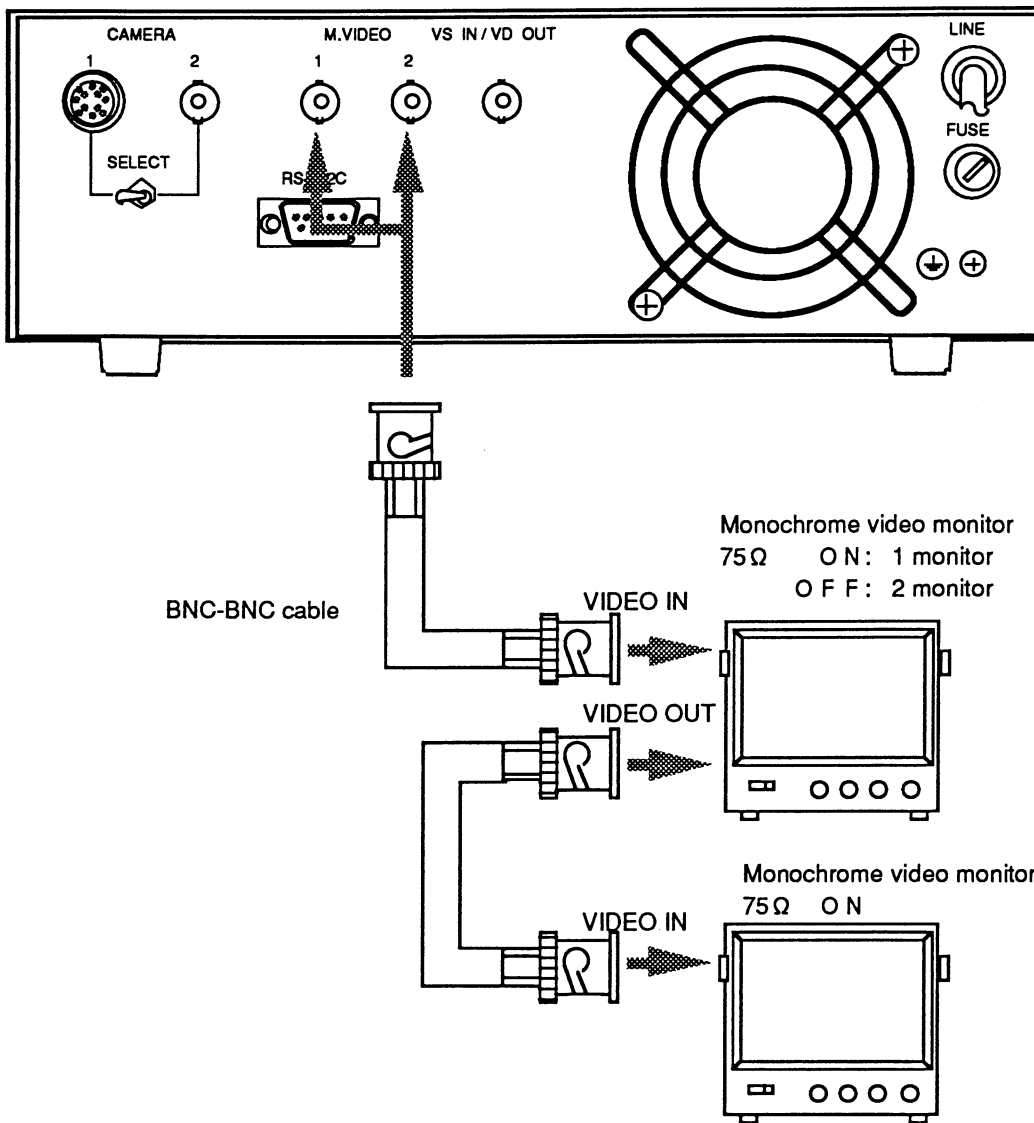

Connect the M. VIDEO connector on the camera control unit to the television monitor (or monitors). When connecting one television monitor, the 75 Ω terminus switch should be set to the "ON" position. When connecting two or more monitors, set the switch of the last monitor in the series to "ON"; the others should be set to the "OFF" position. When connecting two or more monitors, extra cables must be purchased separately.

7 . Before Operating the Equipment

Turning on the power and producing an image on the monitor

1.Cables

Check to make sure the various cables have been connected properly. Make sure the power supply cables for each unit have been plugged into wall outlets.

2.Turn on the power supply to the video monitor.

Check to make sure the power supply lamp is lighted.

3.Turning on the power supply to the C2400-60

Before turning on the power supply, set the knobs on the front panel to the following positions:

- Turn the GAIN (CONTRAST ENHANCEMENT) knob all the way to the left.
- Turn the OFFSET (CONTRAST ENHANCEMENT) knob all the way to the right.
- Turn the DETAIL knob all the way to the left.

Turn on the power supply switch (POWER) and make sure the power supply lamp is lighted.

4. Producing an image on the video monitor

If the image on the monitor is not synchronized properly, turn the H-HOLD and V-HOLD knobs on the monitor until the image is synchronized. Next, adjust the BRIGHTNESS and CONTRAST knobs to the appropriate brightness level.

5. When the image has appeared:

Adjust the focus of the lens to focus the image on the monitor.

Adjust the lens aperture until the green VIDEO LEVEL lamp on the front panel lights.

If the red lamp is lighted, tighten the lens aperture or reduce the brightness of the object being monitored.

The monitor should always be used in the range where the green lamp is lighted.

8 . Operation Method

Contrast enhancement

To produce an image of an object with a low contrast level, the contrast enhancement function can be used to increase the amount of contrast.

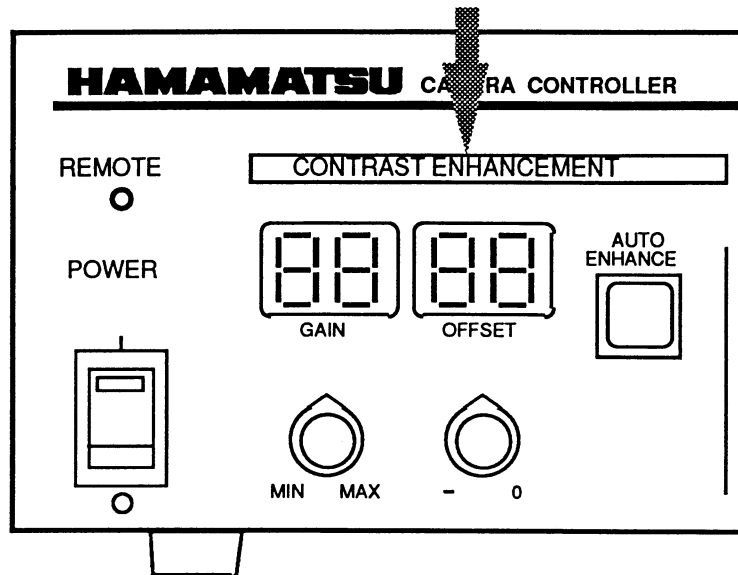

- 1 . Turn the CONTRAST ENHANCEMENT knob on the front panel all the way to the left, and then turn the OFFSET knob all the way to the right.
- 2 . Watching the television monitor, turn the GAIN knob to the right, to the point where the brightness of the image on the television monitor is almost too high.
- 3 . Watching the television monitor, turn the OFFSET knob to the left, to the point where the image on the television monitor is adjusted appropriately.
- 4 . Repeat steps 2 and 3 until the section of the image to be photographed is easiest to see. When the contrast is being enhanced, it may be impossible to enhance the contrast enough if there is shading (uneven brightness) in the image obtained from the object being photographed. If this happens, adjust the illumination of the object so that the brightness is more evenly distributed, or use the shading correction function to improve the shading.

※ Using the Auto Enhance function to adjust the image

With this function, the amount of enhancement varies automatically depending on the object being photographed, making it extremely easy to adjust the contrast enhancement.

- 1 . Press the AUTO ENHANCE switch and check to make sure the switch lights.
- 2 .Make a note of the values registered on the digital GAIN and OFFSET displays.
- 3 .Press the AUTO ENHANCE switch once again to turn off the Auto Enhance function.
- 4 . Set the GAIN and OFFSET switches to the values previously read.
- 5 .If necessary, the knobs can be further adjusted to find the optimum viewing conditions.

CAUTION

Raising the level of contrast enhancement too far results in excessive image output, and this can cause deterioration of the images produced on any image processing equipment and the television monitor connected to the camera control unit. If this happens, lower the GAIN level or use the OFFSET knob to reduce the image output.

Shading corrector

The four SHADING knobs on the front panel can be used to correct the shading, including the shading of the optics system. Shading correction can be carried out in the NORMAL (horizontal/vertical) mode or in the DIAGONAL mode.

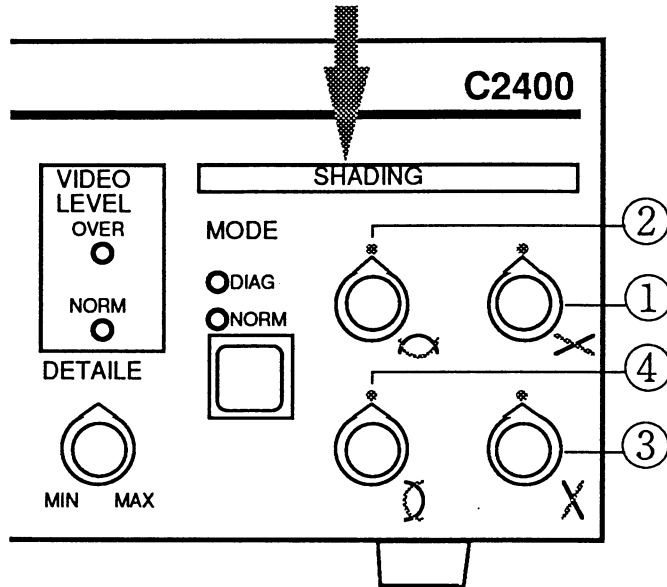

1. Normal Correction

When the MODE (SHADING) switch on the front panel is off, pressing the switch once causes the NORM lamp to light and accesses the Normal correction mode.

Pressing knob ①

When the knob is turned to the right:

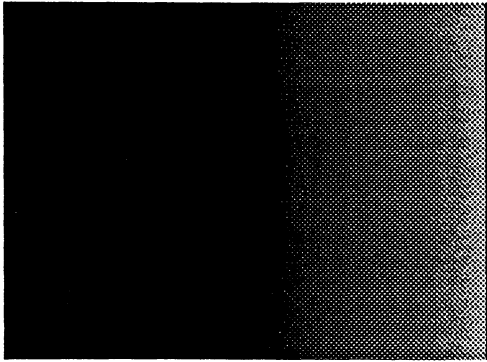

When the knob is turned to the left:

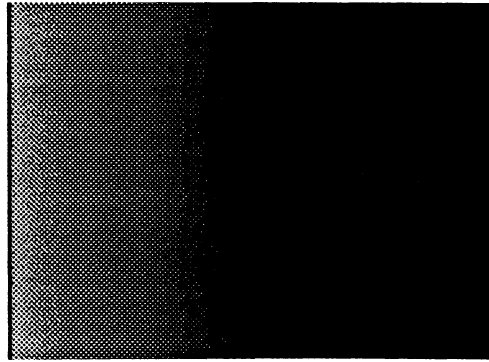

Pressing knob ②

When the knob is turned to the right:

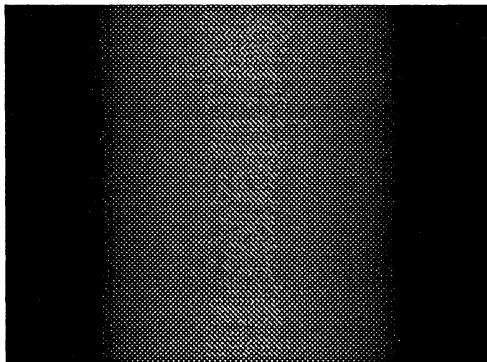

When the knob is turned to the left:

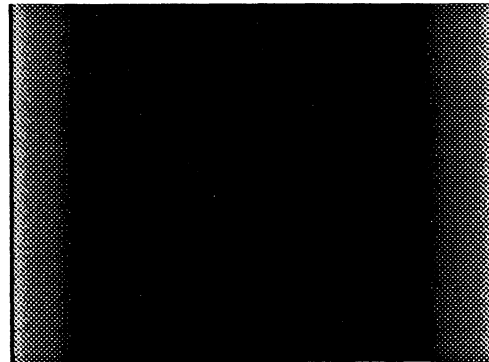

Pressing knob③

When the knob is turned to the right:

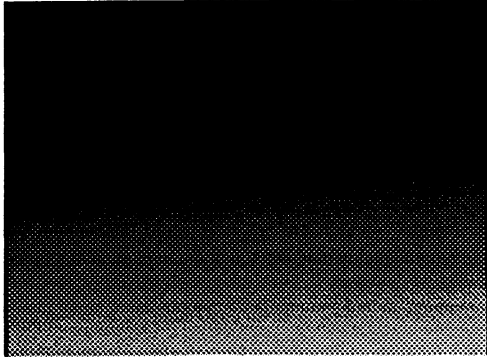

When the knob is turned to the left:

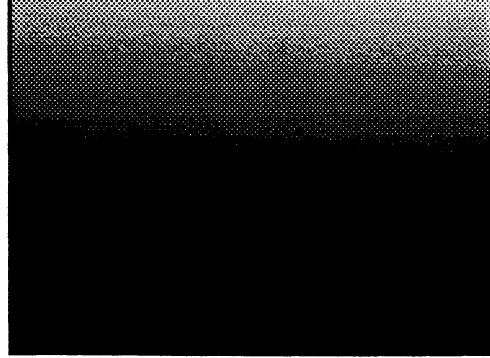

Pressing knob④

When the knob is turned to the right:

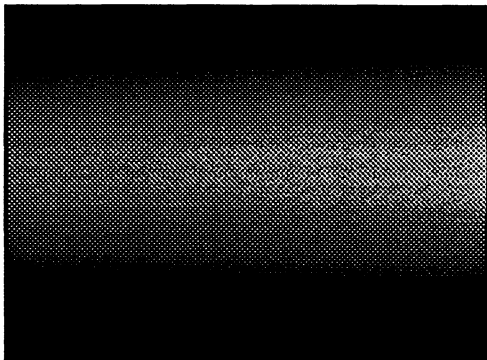

When the knob is turned to the left:

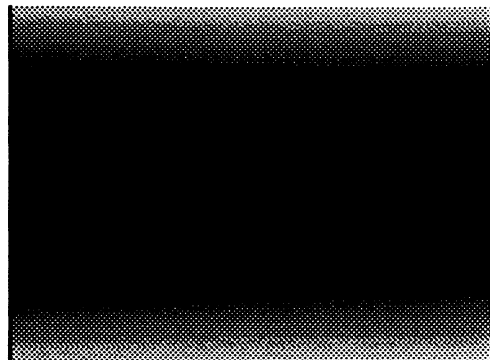

2 .Diagonal Correction

When the MODE (SHADING) switch on the front panel is off, pressing the switch twice causes the DIAG lamp to light and accesses the Diagonal correction mode.

Pressing knob①

When the knob is turned to the right:

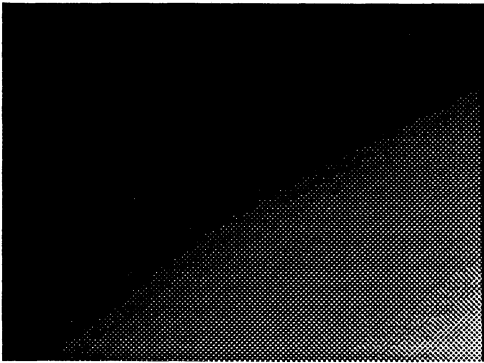

When the knob is turned to the left:

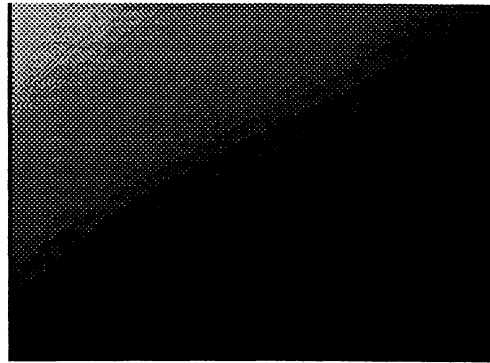

Pressing knob②

When the knob is turned to the right:

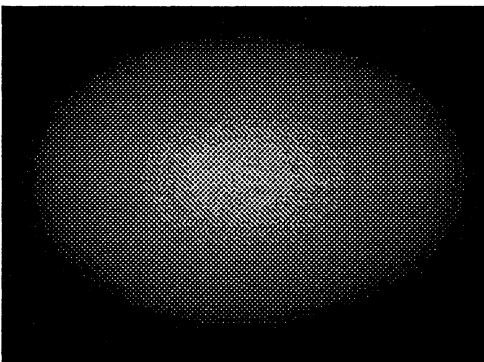

When the knob is turned to the left:



Operation Method Shading corrector

Pressing knob③

When the knob is turned to the right:

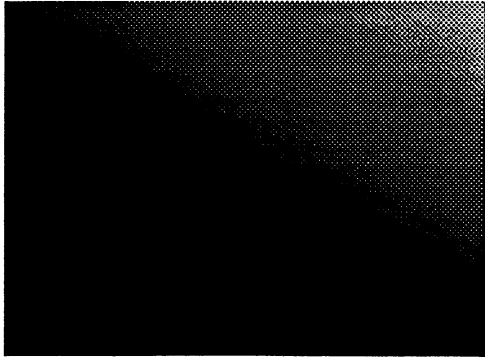

When the knob is turned to the left:

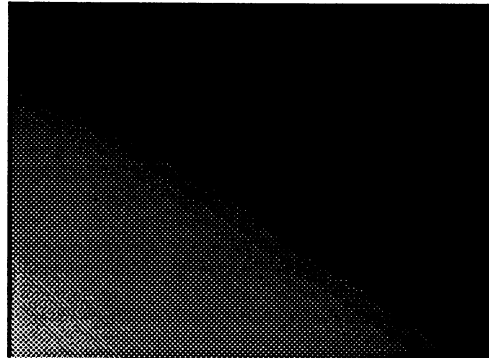

Pressing knob④

When the knob is turned to the right:

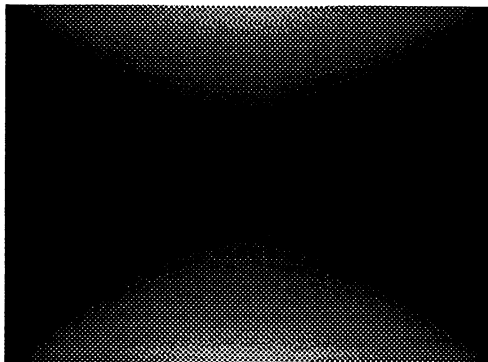

When the knob is turned to the left:

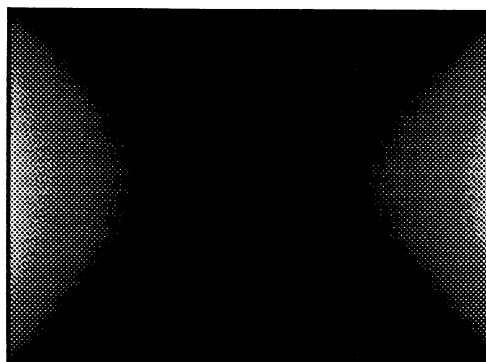

Video Inverter (NEGA)

The intensity of the image can be reversed, so that it appears like a film negative. This function can be selected whenever appropriate to the application.

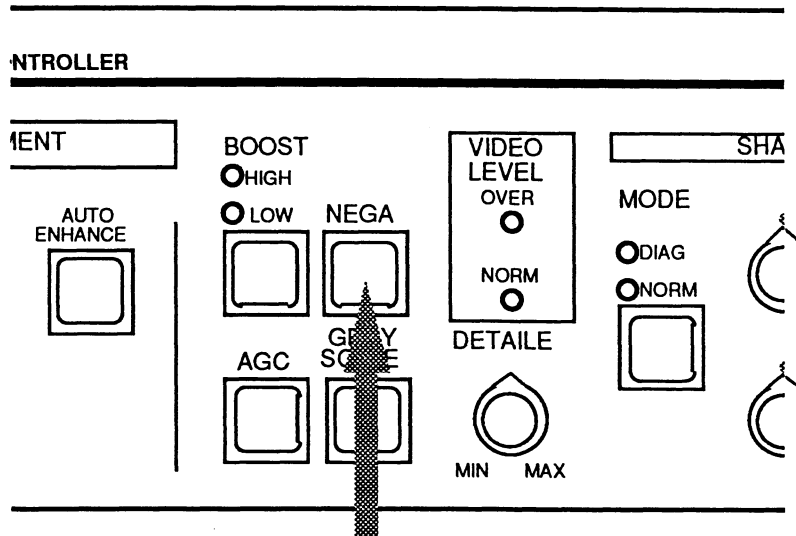

Pressing the NEGA switch on the front panel causes the switch to light and reverses the image on the monitor. If the switch is pressed once more, the image returns to its normal display.

Further enhancing the contrast while the image is reversed allows images with dark sections to be produced in finer detail.

Example:

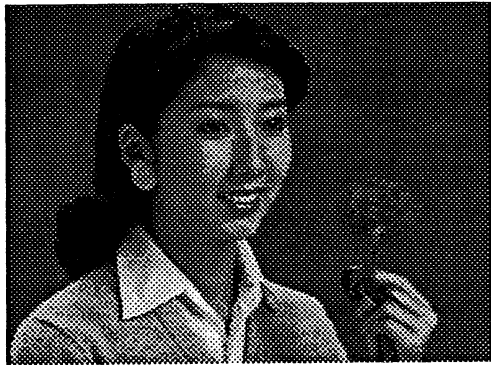

Normal image

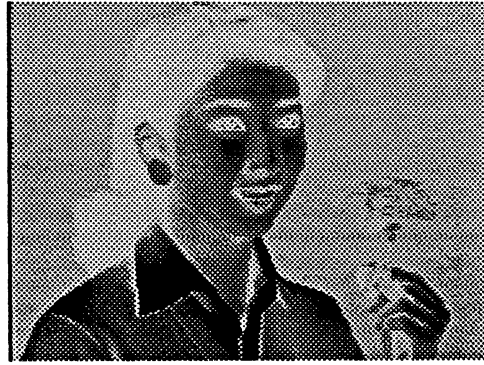

Reversed image

Video Booster (BOOST)

The video booster can be used to change the intensity of the image (change the brightness of the video signal to a different brightness) in order to enhance sections of the image with a low intensity level. The intensity conversion characteristic should be set to $\gamma = 0.75$ (LOW) , 0.45 (HIGH)

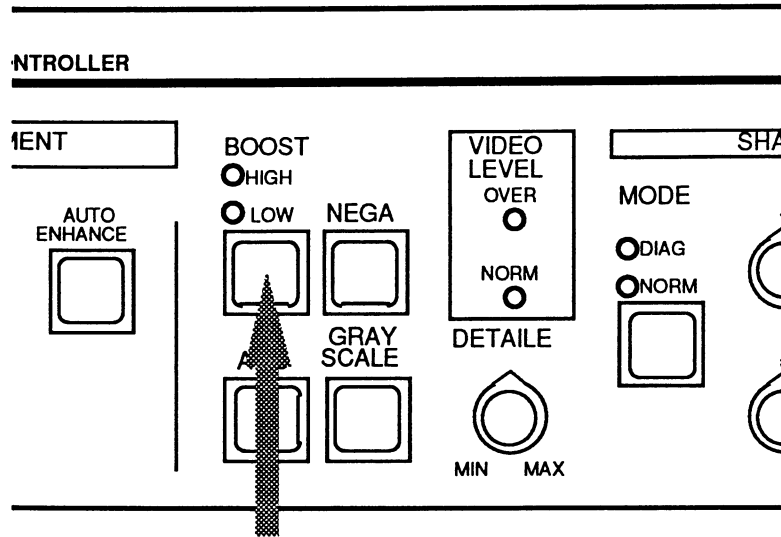

Pressing the BOOST switch on the front panel once causes the LOW lamp to light and sets the intensity conversion characteristic to $\gamma = 0.75$. Pressing the switch once more causes the HIGH lamp to light and sets the intensity conversion characteristic to $\gamma = 0.45$. For a normal image (when the BOOST switch is off), the intensity conversion characteristic is $\gamma = 1$.

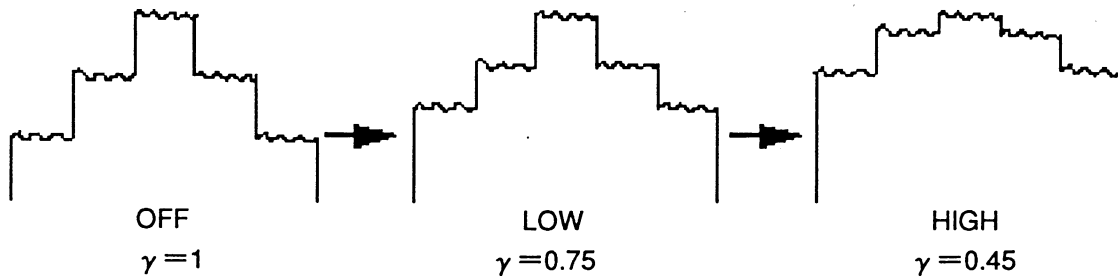

Auto Gain Control (AGC)

This function allows the output video signals to be maintained at a uniform level despite fluctuation in the amount of incident light.

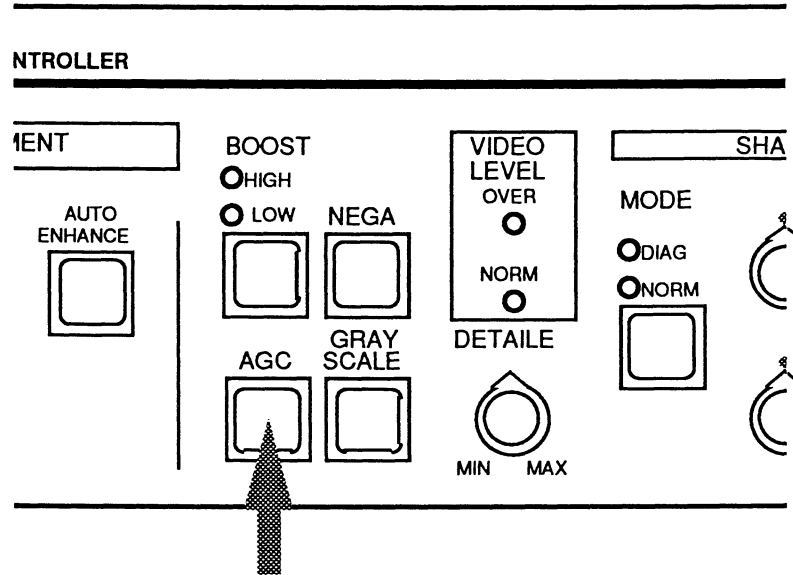

Under standard conditions (with the Auto Gain Control function off), the volume of light or the lens aperture is adjusted so that the green VIDEO LEVEL lamp on the front panel lights. When the AGC switch on the front panel is pressed, the switch lights and the Auto Gain Control function is activated. When this function is on, the amplifier gain is adjusted automatically, and uniform video signals are output.

CAUTION

If there is no incident light, or if the level of incident light is too low, the amplifier gain will be set at the maximum level. This results in a poor S/N ratio. If the red VIDEO LEVEL lamp is lighted, the amount of incident light is excessive. Close the lens aperture or reduce the amount of light on the object being photographed.

Detail Enhancement (DETAIL)

This function makes it possible to enhance the contour of the image. The contour can be enhanced within a range of 0 to 2 times the original level, in order to make the image easier to see.

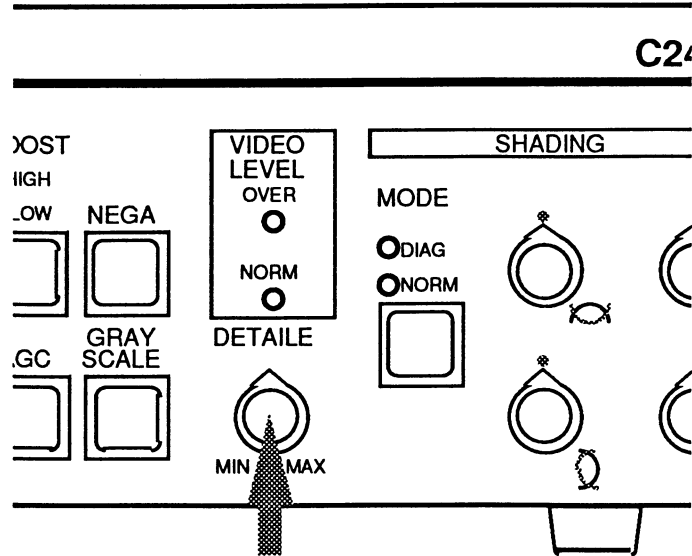

Turning the DETAIL knob on the front panel to the right increases the contour enhancement. Turning the knob to the left returns the image to its normal display.

Example:



Normal image



Image with enhanced contour

Gray Scale (GRAY SCALE)

This function displays the gray scale at the right edge of the monitor screen.

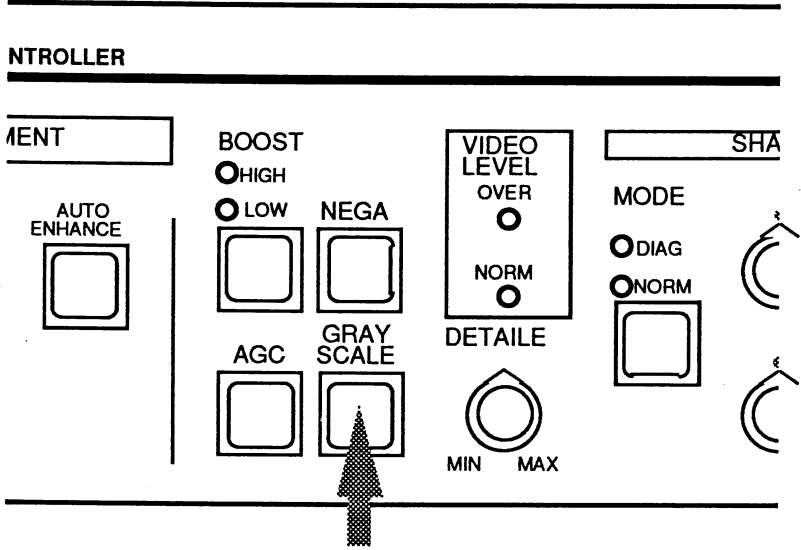

Pressing the GRAYSCALE switch on the front panel causes the switch to light and displays the gray scale at the right edge of the monitor. Pressing it once more turns off the display and returns the screen to its normal status.



External Synchronization (VS IN/VD OUT)

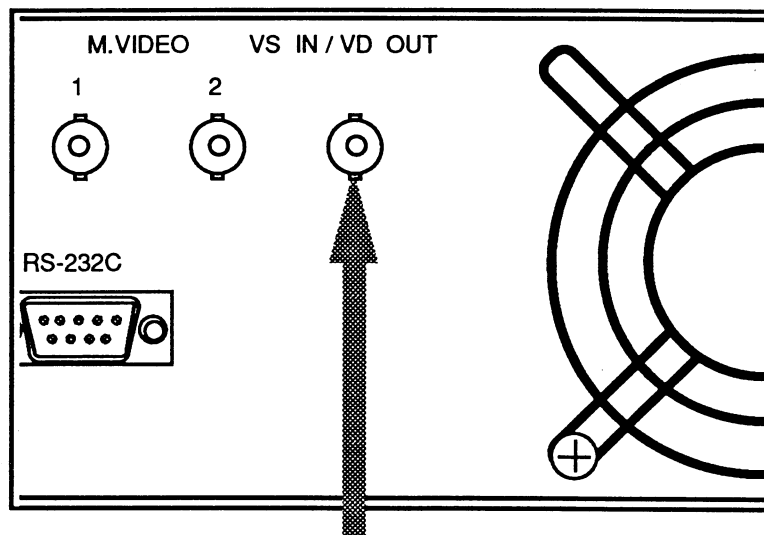

With this camera control unit, there is no sync signal generating circuit. Instead, signals are synchronized to composite video signals input from an external source. Therefore, as a condition when external synchronization is applied, the external synchronization must be received on the camera side.

When external synchronization is applied, SYNC signals (negative logic) or VBS signals should be input from the VS IN/VD OUT jack on the rear panel. When the camera control unit is shipped from the factory, however, VD signals (negative logic) synchronized to the camera are output. Therefore, internal jumpers have to be changed before external synchronization can be used. To use external synchronization, please contact HAMAMATSU.

9. External Control Command Specifications

Communications Interface

The various functions of the C2400-60 Camera Control Unit (contrast enhancement, video booster, auto gain control, video inverter, gray scale, and shading corrector) can be controlled externally, from a host computer, through a serial interface. The settings for the serial interface are listed below.

Baud rate	9600
Bit length	8
Parity check	NON
Stop bit	1

These settings are fixed and cannot be changed. Please change the settings on the host computer to match.

Command Format

1 Basic Format

External commands for the C2400-60 are output from the host computer in the following format:

Command _ Parameter CR (CR: Carriage Return)

Commands are output with the <CR> code appended as the last data in the command.

When the command requires a parameter, a space is used to separate the command from the parameter.

2 Interpreting Commands

Commands sent from the host computer to the camera are accumulated in the internal buffer in sequential order. Once the contents of the commands have been interpreted, the commands are executed while the camera is in the vertical blanking phase.

Camera responses to commands

1 Specifying whether a response is to be sent

The camera responds to commands sent from the host computer. The RESponse command can be used to specify whether or not there is to be a response from the camera when a command is sent. For status commands, however, it is not possible to instruct the camera not to respond.

Command:	RES (RESponse)
Function:	Specifies whether or not there is to be a response from
Parameter:	O/F
O:	The camera responds to each individual command.
F:	The camera does not respond to each individual command.

If the RES command specifies that there is to be a response, the camera sends its response at the point at which the received command has actually been executed. Therefore, the response varies depending on the type of command sent.

2 Response to executed commands and setting commands

When the command has been executed normally, the camera returns the executed command (with its parameters) to the host computer.

```

X X X _ P P      C R   X X X : Executed command
                    P P : Parameter
    
```

If there is an error in the command sent from the host computer (an undefined command or an error in a parameter), the following character string is sent back as an error.

```

E 3   C R
    
```

3 Response to status commands

(This is always output, regardless of the RES command setting.)

If the camera interprets the command to be correct, it sends back the required status in response to a status command from the host computer. Therefore, if the status command is executed normally, the status is sent back to the host computer as the response.

```

X X X _ P P   C R   X X X :   Command name (3 characters excluding the ? symbol)
                P P :   Status of command
    
```

If there is an error in the command sent from the host computer (an undefined command, etc.), the following character string is sent back as an error, in the same way as described above.

```

E 3   C R
    
```

4 If an error occurs when a command is received

If there is any problem in the received command, the following two possibilities should be considered: one is that there is a framing, parity, or overrun error, and the other is that there is an overflow in the reception buffer. If any of these errors occur, the following character string is sent back to the computer at the point where the error occurs.

```

E n   C R
    
```

Here, "n" indicates the type of error, and the subsequent number indicates the specific contents.

n = 1: Framing, parity, or overrun error

n = 2: Reception buffer overflow

If either of the above two types of errors occurs, the command in which the error occurred is cancelled from the reception buffer in the camera.

An outline of the commands

External control commands are divided into the two types listed below.

- Setting commands
- Status command group

With status commands, a response is sent back from the camera side after a command is output from the host computer. All status commands begin with a question mark, and consist of the pertinent setting command with a question mark at the beginning.

1 Setting commands

These are used to specify the initial values for the knobs and switches on the front panel, as well as initial system values.

C E C : Selects the switch for the contrast enhancement function.

C E G : Specifies the gain level when the contrast is being enhanced through external control.

C E O : Specifies the offset level when the contrast is being enhanced through external control.

S H C : Selects the switch for the shading correction function.

A G C : Selects the switch for the auto gain control function.

I N V : Selects the switch for the video inverter function.

G R Y : Selects the switch for the gray scale function.

G M A : Selects the switch for the video booster function.

I N I : Initializes the values set for various camera conditions.

R E S : Selects whether or not a response is to be sent when a command is output.

R M T : Sets and cancels the external control mode.

2 Status commands

- ? V E R : Returns the ROM version in the camera.
- ? C E C : Returns the value set for the contrast enhancement function switch.
- ? C E G : Returns the value set for the gain level when the contrast is being enhanced through external control.
- ? C E O : Returns the value set for the offset level when the contrast is being enhanced through external control.
- ? C V G : Returns the value set for the gain level when the contrast is being enhanced using the knob on the front panel.
- ? C V O : Returns the value set for the offset level when the contrast is being enhanced using the knob on the front panel.
- ? S H C : Returns the value set for the shading correction function switch.
- ? A G C : Returns the value set for the auto gain control function switch.
- ? I N V : Returns the value set for the video inverter function switch.
- ? G R Y : Returns the value set for the gray scale function switch.
- ? G M A : Returns the value set for the video booster function switch.
- ? V T P : Returns the maximum value for the video signal.
- ? V B T : Returns the minimum value for the video signal.
- ? R E S : Returns the setting for the command response.
- ? R M T : Returns the setting for the remote operation mode.

Command Communications

1 Setting commands

Command : C E C (Contrast Enhance Control)

Parameter : Volume / External / Auto

Function : Selects the contrast enhancement function.

(Example)

C E C__V . . . Control is handled using the knob on the C2400-60 controller.

C E C__E . . . Control is handled using the CEG and CEO commands.

C E C__A . . . Activates the auto gain control function.

Command : C E G (Contrast Enhance Gain)

Parameter : n (0 - 100)

Function : Sets the gain level when the contrast is being enhanced through external control.

(Example)

C E G__50 . . . Sets the gain to 5.0.

C E G__100 . . . Sets the gain to 10.

Comment: The display on the front panel shows figures from 0.0 to 10, but the actual value is the display value multiplied by 10.

Command : C E O (Contrast Enhance Offset)

Parameter : n (0 - 100)

Function : Sets the offset level when the contrast is being enhanced through external control.

(Example)

C E O__50 . . . Sets the offset to 5.0.

C E O__100 . . . Sets the offset to 10.

Comment: The display on the front panel shows figures from 0.0 to 10, but the actual value is the display value multiplied by 10.

Command : S H C (S Hading Control)

Parameter : Normal / Diagonal / o F f

Function : Selects the shading correction function.

(Example)

S H C __ N . . . The shading correction knob on the front panel is effective. This is for standard or normal shading correction.

S H C __ D . . . The shading correction knob on the front panel is effective. This is for diagonal shading correction.

S H C __ F . . . - The shading correction knob on the front panel is not effective.

Command : A G C (Auto Gain Control)

Parameter : On / o F f

Function : Selects the auto gain control function.

(Example)

A G C __ O . . . Turns on the auto gain control function.

A G C __ F . . . Turns off the auto gain control function.

Command : I N V (video I N Verter)

Parameter : On / o F f

Function : Selects the video inverter function.

(Example)

I N V __ O . . . Turns on the video inverter function.

I N V __ F . . . Turns off the video inverter function.

Command : G R Y (G R a Y scale)

Parameter : On / o F f

Function : Selects the gray scale function.

(Example)

G R Y __ O . . . Turns on the gray scale function.

G R Y __ F . . . Turns off the gray scale function.

Command : GMA (GaMmA corrector)
 Parameter : High/Low/oFf
 Function : Selects the video booster function.

(Example)

GMA__H . . . Turns on the video booster function. $\gamma = 0.45$.
 GMA__L . . . Turns on the video booster function. $\gamma = 0.75$.
 GMA__F . . . Turns on the video booster function. $\gamma = 1.0$.

Command : I N I (I N I tialize)
 Parameter : None
 Function : Initializes the contents of the backup RAM in the camera control buffer.

Command : R E S (R E S ponse)
 Parameter : On/oFf
 Function : Specifies whether or not a response is to be sent each time a command is executed.

(Example)

R E S__O . . . A response is sent each time a command is executed.
 R E S__F . . . No response is sent when a command is executed.

Command : R M T (R e M o T e)
 Parameter : On/oFf
 Function : Specifies whether control is to be handled through the external control mode, or using the knobs and switches on the front panel.

(Example)

R M T__O . . . The external control mode is accessed, and the knobs and switches on the front panel become ineffective.
 R M T__F . . . The external control mode is cancelled, and the knobs and switches on the front panel become effective.

2 Status commands

Status commands return the currently specified value.

Command	: ? V E R (read V E R sion)
Function	: Returns the ROM version in the camera.
Returned value	: X . X
Command	: ? C E C (read Contrast Enhance Control)
Function	: Returns the status of the contrast enhancement function.
Returned value	: V / E / A
Command	: ? C E G (read Contrast Enhance Gain)
Function	: Returns the value for the external gain level of the contrast enhancement function.
Returned value	: n (0 - 1 0 0)
Command	: ? C E O (read Contrast Enhance Offset)
Function	: Returns the value for the external offset level of the contrast enhancement function.
Returned value	: n (0 - 1 0 0)
Command	: ? C V G (read Contrast enhance Volume Gain)
Function	: Returns the value for the gain level of the contrast enhancement function set using the front panel knob.
Returned value	: n (0 - 1 0 0)
Command	: ? C V O (read Contrast enhance Volume Offset)
Function	: Returns the value for the offset level of the contrast enhancement function set using the front panel knob.
Returned value	: n (0 - 1 0 0)
Command	: ? S H C (read S Hading Control)
Function	: Returns the status of the shading correction function.
Returned value	: N / D / F
Command	: ? A G C (read Auto Gain Control)
Function	: Returns the status of the auto gain control function.
Returned value	: O / F
Command	: ? I N V (read video I N V ertter)
Function	: Returns the status of the video booster function.
Returned value	: O / F

Command : ? G R Y (read G R a Y scale)
Function : Returns the status of the gray scale function.
Returned value : O / F

Command : ? G M A (read G a M m A corrector)
Function : Returns the status of the video booster function.
Returned value : H / L / F

Command : ? V T P (read Video To P)
Function : Returns the maximum value for the video signal.
Returned value : n (0 - 1 0 0)

Command : ? V B T (read Video Bo T tom)
Function : Returns the minimum value for the video signal.
Returned value : n (0 - 1 0 0)

Command : ? R M T (read Re Mo Te)
Function : Returns the status of the remote control function.
Returned value : O / F

Command : ? R E S (read R E Sponse)
Function : Returns the status of the response.
Returned value : O / F

10. Maintenance

1. Cleaning

Any dirt on the control unit should be lightly wiped off with a dry cloth. If the control unit is extremely dirty, dip a cloth lightly in a neutral cleaning solvent, wring it out, and wipe the control unit. Then wipe the unit with a dry cloth.

2. If a breakdown occurs

In the event that you notice any unusual noise, odor, or smoke coming from the control unit, immediately turn off the power supply, unplug the power supply cord from the wall outlet, and contact HAMAMATSU or a HAMAMATSU sales representative.

If any other problems occur, such as no image being produced on the television monitor, or poor image quality, please check the items listed on the following page. If the problem cannot be corrected by following the steps listed here, please contact HAMAMATSU or a HAMAMATSU sales representative and describe the symptoms in detail.

11. Before Requesting Repair

If the equipment does not work properly, or there is some problem with operation, please check the following items before consulting a HAMAMATSU sales representative.

Symptom	Check Item
No image appears on the television monitor.	<ul style="list-style-type: none"> · Are the pilot lamps on the camera control unit and the television monitor lighted? · Has a cable been disconnected from its plug? · Have the camera control unit and the camera head been connected properly? · Has the OFFSET knob on the front panel been turned all the way to the right? · Has the GAIN knob on the front panel been turned all the way to the left? · Has the light path between the camera head and the object being photographed been obstructed? · Is there too little incident light on the object being photographed, so that the green VIDEO LEVEL lamp on the front panel has gone out? · Is there too much incident light on the object being photographed, so that the red VIDEO LEVEL lamp on the front panel has lighted?
The image does not appear clearly, in detail.	<ul style="list-style-type: none"> · Is there too little incident light on the object being photographed, so that the green VIDEO LEVEL lamp on the front panel has gone out? · Has the contrast level for the television monitor been adjusted properly? · Has the optics system focus been adjusted properly? · Is there a problem with the resolution of the optics system? · Is there a problem with the chromatic aberration of the optics system? · Is the optics system or the photographing plate of the camera dirty?
There is noise in the image.	<ul style="list-style-type: none"> · Is there too little incident light on the object being photographed, so that the green VIDEO LEVEL lamp on the front panel has gone out? (If the GAIN knob on the front panel is used for adjustment when photographing a dark object, noise can result. Rather than using the GAIN knob, increase the amount of incident light on the target.) · Is there too little incident light on the object being photographed, so that the AGC function has gone on? · Is the terminus (75 Ω) of the television monitor on? (Under normal usage conditions, this is on.) · Have the camera head and the optics system been connected correctly, and is electricity being conducted? · Is there any external source which is generating noise?
The image is distorted.	<ul style="list-style-type: none"> · Is there any problem with optics system distortion? · Have the H-HOLD and V-HOLD knobs on the television monitor been adjusted correctly? · Has the contrast level been set too high?
There is too much shading.	<ul style="list-style-type: none"> · Has the shading correction value been adjusted to the appropriate value? · Is there any problem with the optics system?

- | | | |
|--------------------------------|--|--|
| 14. Power supply | NTSC B/W | AC100V/117V $\pm 10\%$ 50/60Hz
(internal switching of tap possible) |
| | CCIR SYSTEM-B | AC220V/240V $\pm 10\%$ 50/60Hz
(internal switching of tap possible) |
| 15. Power consumption | 45VA (when C3077 is used) | |
| 16. Storage temperature | -10°C ~ +50°C | |
| 17. Operating temperature | 0°C ~ +40°C | |
| 18. Storage/operating humidity | 90% max. (with no condensation) | |
| 19. External dimensions | 232(W) \times 74(H) \times 308(D) mm | |
| 20. Weight | Approx. 4 kg | |

