

Site Preparation
for SGI™ 2000-Series, Origin™ Family,
Onyx2®, Octane®, and O2®

Document Number 007-3452-004

CONTRIBUTORS

Written by Eric Zamost

Illustrated by Cheri Brown and Dan Young

Production by Glen Traefald

Additional contributions by Charles Alexander, Dave Alexander, Dilip Amin, Jim Ammon, Karen Andrews, Mark Aubin, Judy Bergwerk, Bob Cook, Steve Dean, Dan Farmer, Steve Hawley, Bob Hoehn, Lauro Manalac, Ed Massey, Tom Mitchell, Ali Mira, Phil Montalban, Richard Nagel, Ron Naminski, David North, Bob Riccomini, Tony Roaque, Joan Roy, Greg Schaem, Richard Singer, Jeff Smith, Carl Strasen, Jim Tennesen, Ting-Yu Tsang, Ted Wong, and Linda Zupic

Cover design by Sarah Bolles, Sarah Bolles Design, and Danny Galgani, SGI Technical Publications.

© 2000, Silicon Graphics, Inc. All rights reserved.

The contents of this document may not be copied or duplicated in any manner, in whole or in part, without the prior written permission of Silicon Graphics, Inc.

LIMITED AND RESTRICTED RIGHTS LEGEND

Use, duplication, or disclosure by the Government is subject to restrictions as set forth in the Rights in Data clause at FAR 52.227-14 and/or in similar or successor clauses in the FAR, or in the DOD, DOE or NASA FAR Supplements. Unpublished rights reserved under the Copyright Laws of the United States.

Contractor/manufacturer is Silicon Graphics, Inc., 1600 Amphitheatre Pkwy., Mountain View, CA 94043-1351.

Silicon Graphics, Challenge, InfiniteReality, O2, Octane, Onyx, Onyx2, Onyx2 InfiniteReality, and RealityMonster are registered trademarks and SGI, the SGI logo, Onyx2 Reality, and Origin are trademarks of Silicon Graphics, Inc. Indy is a registered trademark used under license in the U.S. and owned by Silicon Graphics, Inc. in other countries worldwide.

CrayLink is a trademark of Cray, Inc. MIPS is a registered trademark of MIPS Technologies, Inc. PS/2 is a registered trademark of IBM.

Disclaimer and Use Warning

This Site Preparation Guide (the "Guide") is intended for use by Silicon Graphics, Inc. ("SGI") employees, customers, and other business partners only.

Warning: Certain information in this Guide pertains to (i) preparation of site power circuitry for the installation of the Silicon Graphics product(s) covered by this Guide, and (ii) installation of safety and fire and other protection equipment and mechanisms related to the use of Silicon Graphics products. THIS INFORMATION SHOULD BE USED ONLY BY AN APPROPRIATELY LICENSED AND EXPERIENCED TECHNICIAN IN ACCORDANCE WITH APPLICABLE GOVERNMENTAL RULES, REGULATIONS, AND CODES.

You may not distribute or modify the information in this Guide in whole or in part without the prior written permission of Silicon Graphics. You may print, reproduce, and use the information in this Guide for your internal use only, provided that you (i) do not modify any of such information, and (ii) include this notice in all such copies.

The information and data included in this Guide are subject to change without notice from Silicon Graphics Inc. SILICON GRAPHICS SPECIFICALLY DISCLAIMS ALL WARRANTIES WITH RESPECT TO THE INFORMATION IN THIS GUIDE OR YOUR USE HEREOF, EXPRESS, IMPLIED, OR OTHERWISE, INCLUDING WITHOUT LIMITATION, ALL WARRANTIES OF MERCHANTABILITY AND FITNESS FOR A PARTICULAR PURPOSE. SILICON GRAPHICS SHALL NOT BE LIABLE FOR ANY SPECIAL, INCIDENTAL, OR CONSEQUENTIAL DAMAGES, INCLUDING, WITHOUT LIMITATION, LOST REVENUES, LOST PROFITS, OR LOSS OF PROSPECTIVE ECONOMIC ADVANTAGE, RESULTING FROM THE USE OR MISUSE OF THIS GUIDE, OR THE INFORMATION HEREIN.

FCC Warning

This equipment has been tested and found compliant with the limits for a Class A digital device, pursuant to Part 15 of the FCC rules. These limits are designed to provide reasonable protection against harmful interference when the equipment is operated in a commercial environment. This equipment generates, uses, and can radiate radio frequency energy and, if not installed and used in accordance with the instruction manual, may cause harmful interference to radio communications. Operation of this equipment in a residential area is likely to cause harmful interference, in which case the user will be required to correct the interference at his or her own expense.

Attention

This product requires the use of external shielded cables in order to maintain compliance pursuant to Part 15 of the FCC Rules.

Site Preparation for SGI™ 2000-Series, Origin™ Family, Onyx2®, Octane®, and O2®
Document Number 007-3452-004

Contents

List of Figures xi

List of Tables xv

About This Guide xvii

Guide Organization xvii

The SGI Product Line xviii

Additional Documentation xix

Reader Comments xix

- 1. Planning the Installation** 1
 - Organizing Activities 2
 - Site Preparation Checklist 3
 - Site Preparation Checklist Details 4
 - Verify Intended Site 4
 - Install Power and Air Conditioning 5
 - Prepare Physical Location 5
 - Prepare to Receive Shipment 6
 - Prepare for External Cabling 7
- 2. Site Preparation Concepts** 9
 - Physical Location 10
 - Selecting a Delivery Route 10
 - Selecting a Final Location 11

- Electrical Requirements 13
 - Voltage Requirements 13
 - Power Requirements 14
 - Grounding Requirements 15
 - Power Factor 15
 - Inrush Current 15
 - Total Harmonic Distortion 16
- Thermal Requirements 17
 - Heat Output 17
 - Air Conditioner Terminology 17
 - Calculating Thermal Load 18
 - Thermal Gradient 19
 - Cooling In Mission-Critical Installations 19
- Environmental Requirements 20
 - Electromagnetic Interference 20
 - Electrostatic Discharge 20
 - Vibration 21
 - Humidity 21
 - Humidity Gradient 21
- Ergonomic Requirements 22
 - Acoustics 22
- Local Regulations 23
- Planning for the Future 23
- Converting Between U.S. Customary Measure and Metric Measure 24
- 3. Site Preparation for O2 Systems 27**
 - Selecting a Location for an O2 System 28
 - O2 Site Requirements 30
 - O2 Specifications 30
 - O2 Power and Cooling Requirements 31
 - O2 External Peripherals 32
 - O2 Cabling Issues 32

4.	Site Preparation for Octane	33
	Selecting a Location for an Octane System	34
	Octane Site Requirements	37
	Octane Specifications	37
	Octane Power and Cooling Requirements	38
	Octane External Peripherals	39
	Octane Cabling Issues	39
5.	Site Preparation for Origin200 and Origin Vault	41
	Selecting a Location for an Origin200 or Origin Vault System	42
	Feet on Origin200 and Origin Vault Systems	42
	Clearances for Origin200 and Origin Vault Systems	44
	Airflow in Origin200 and Origin Vault Systems	45
	Wiring and Grounding Requirements for Origin200 and Origin Vault Systems	46
	Origin200 Site Requirements	47
	Origin200 Specifications	47
	Origin200 Power and Cooling Requirements	48
	Origin200 External Peripherals	49
	Origin200 Cabling Issues	50
	Origin Vault Site Requirements	51
	Origin Vault Specifications	51
	Origin Vault Power and Cooling Requirements	52
	Origin Vault SCSI-Cable Considerations	53
6.	Site Preparation for SGI 2000-Series and Onyx2 Base Modules and Deskside Systems	55
	SGI 2000-Series Deskside and Onyx2 Deskside Shipping Crate	56
	Selecting a Location for an SGI 2000-Series Deskside or Onyx2 Deskside System	57
	Airflow Clearance for SGI 2000-Series Deskside and Onyx2 Deskside Systems	58
	Service Clearance for SGI 2000-Series and Onyx2 Deskside Systems	58
	Airflow in SGI 2000-Series Deskside and Onyx2 Deskside Systems	59
	Casters on SGI 2000-Series Deskside and Onyx2 Deskside Systems	60

- SGI 2000-Series Base Module Site Requirements 61
 - SGI 2000-Series Base Module Specifications 61
 - SGI 2000-Series Base Module Power and Cooling Requirements 62
 - SGI 2000-Series Base Module External Peripherals 64
 - SGI 2000-Series Base Module Cabling Issues 64
- Onyx2 Deskside System Site Requirements 65
 - Onyx2 Deskside System Specifications 65
 - Onyx2 Deskside System Power and Cooling Requirements 66
 - Onyx2 Deskside System External Peripherals 68
 - Onyx2 Deskside System Cabling Issues 69
- 7. Site Preparation for Onyx2 Graphics Insert Modules 71**
 - Selecting a Location for an Onyx2 Graphics Insert Module 72
 - Airflow in Onyx2 Graphics Insert Modules 73
 - Onyx2 Graphics Insert Module Site Requirements 74
 - Onyx2 Graphics Insert Module Specifications 74
 - Onyx2 Graphics Insert Module Power and Cooling Requirements 75
 - Onyx2 Graphics Insert Module External Peripherals 76
 - Onyx2 Graphics Insert Module Cabling Issues 77
- 8. Site Preparation for SGI 2000-series, Origin Peripherals, and Onyx2 Rack Chassis 79**
 - SGI 2000-Series, Origin Peripherals, and Onyx2 Rack System Shipping Crate 80
 - Selecting a Location for an SGI 2000-Series, Origin Peripherals, or Onyx2 Rack System 81
 - Selecting a Location for a Single SGI 2000-Series, Origin Peripherals, or Onyx2 Rack System 82
 - Clearances for SGI 2000-Series, Origin Peripherals, or Onyx2 Rack Systems 82
 - Floor Loading for SGI 2000-Series, Origin Peripherals, and Onyx2 Rack Systems 84
 - Airflow for SGI 2000-Series, Origin Peripherals, and Onyx2 Rack Systems 85
 - Cable Routing for SGI 2000-Series, Origin Peripherals, and Onyx2 Rack Systems 90

Selecting a Location for Multiple SGI 2000-Series, Origin Peripherals, or Onyx2 Rack Systems	92
Grounding Multiple SGI 2000-Series or Onyx2 Rack Systems	92
CrayLink Cabling Multiple SGI 2000-Series or Onyx2 Rack Systems	92
Multiple SGI 2000-Series or Onyx2 Rack System Recommended Clearances	92
SGI 2000-Series, Origin Peripherals, and Onyx2 Rack Chassis Internal Wiring	96
SGI 2000-Series Rack Chassis Site Requirements	97
SGI 2000-Series Rack Chassis Specifications	97
SGI 2000-Series Rack Chassis Power and Cooling Requirements	98
SGI 2000-Series Rack Chassis External Peripherals	100
SGI 2000-Series Rack Chassis Cabling Requirements	100
Origin Peripherals Rack Chassis Site Requirements	101
Origin Peripherals Rack Chassis Specifications	101
Origin Peripherals Rack Chassis Power and Cooling Requirements	102
Origin Peripherals Rack Chassis External Peripherals	104
Origin Peripherals Rack Chassis Cabling Requirements	104
Onyx2 Rack Chassis Site Requirements	105
Onyx2 Rack Chassis Specifications	105
Onyx2 Rack Chassis Power and Cooling Requirements	106
Onyx2 Rack Chassis External Peripherals	108
Onyx2 Rack Chassis Cabling Requirements	108
A. Site Preparation for External Peripherals	109
Monitors	109
Keyboards	112
Mice	112
External SCSI Devices	112
ASCII Terminals	113

- B. Site Power and Power Cables 115**
 - Installing Site Power Circuits 116
 - Reviewing the Site's Physical Requirements 116
 - Wiring the Main Circuit 117
 - Wiring Chassis Branch Circuits 119
 - Phase Balancing 119
 - Chassis Branch Circuit Grounding 119
 - Wiring O2, Octane, Origin200, and Origin Vault Chassis Branch Circuits 121
 - Wiring SGI 2000-Series Deskside and Onyx2 Deskside Chassis Branch Circuits 123
 - Wiring Rack Chassis Branch Circuits 126
 - Power Cables and Connectors 129
 - O2, Octane, Origin200, Origin Vault, and Peripheral Power Cables 130
 - SGI 2000-Series Deskside and Onyx2 Deskside Power Cables 133
 - Onyx2 Graphics Insert Module Power Cables 137
 - SGI 2000-Series, Origin Peripherals, and Onyx2 Rack Power Distribution Units (PDUs) 139
- C. Safety and Protection Equipment 145**
 - Installing Cable-Management Equipment 145
 - Emergency Power-Off Switch 146
 - Fire-Fighting Equipment With an Electrical Rating 146
 - Lightning Protection 147
 - Power-Line Treatment 147
- Index 149**

List of Figures

- Figure 3-1** O2 Typical Configuration 28
- Figure 3-2** O2 Airflow 29
- Figure 4-1** Octane Typical Desktop Configuration 34
- Figure 4-2** Octane Typical Deskside Configuration 35
- Figure 4-3** Octane Airflow 36
- Figure 5-1** Origin200 and Origin Vault Deskside (Tower) Configuration (With Skins) 42
- Figure 5-2** Origin200 and Origin Vault Rack-Mount Configuration and Mounting Hardware 43
- Figure 5-3** Origin200 and Origin Vault Rack Shelf and Mounting Hardware 43
- Figure 5-4** Origin200 and Origin Vault Chassis Clearances 44
- Figure 5-5** Origin200 and Origin Vault Airflow 45
- Figure 6-1** SGI 2000-Series Deskside and Onyx2 Deskside Shipping Crate 56
- Figure 6-2** SGI 2000-Series Deskside Typical Installation, With Terminal (Onyx2 Similar) 57
- Figure 6-3** SGI 2000-Series Deskside and Onyx2 Deskside Airflow 59
- Figure 6-4** SGI 2000-Series Deskside and Onyx2 Deskside Caster Positions 60
- Figure 7-1** Onyx2 Graphics Insert Module, Rear View 72
- Figure 7-2** Onyx2 Graphics Insert Module Airflow 73
- Figure 8-1** SGI 2000-Series, Origin Peripherals, and Onyx2 Rack Chassis Shipping Crate 80
- Figure 8-2** SGI 2000-Series Rack System (Origin Peripherals and Onyx2 Racks Similar, Not Shown) 81
- Figure 8-3** SGI 2000-Series, Origin Peripherals, and Onyx2 Rack Chassis Recommended Clearances 83
- Figure 8-4** SGI 2000-Series Origin2000, Origin Peripherals, and Onyx2 Rack Chassis Caster and Leveler Locations 85
- Figure 8-5** SGI 2000-Series Rack-Chassis Airflow (Shown With Two Base Modules and One Origin Vault) 87

Figure 8-6	Onyx2 Rack-Chassis Airflow (Shown With One Base Module, One Onyx2 Graphics Insert Module, and One Origin Vault) 88
Figure 8-7	Origin Peripherals Rack-Chassis Airflow (Shown With the Maximum of Nine Origin200 or Origin Vault Units) 89
Figure 8-8	SGI 2000-Series, Origin Peripherals, and Onyx2 Rack-Chassis Cable Opening, Raised-Floor Cutout, and Perforated Tile 91
Figure 8-9	Two-Chassis SGI 2000-Series, Origin Peripherals, or Onyx2 Rack Recommended Clearances 93
Figure 8-10	Four-Chassis SGI 2000-Series, Origin Peripherals, or Onyx2 Rack Recommended Clearances 94
Figure 8-11	Nine-Chassis SGI 2000-Series or Onyx2 Rack Recommended Clearances (Center Chassis is a Meta-Router) 95
Figure A-1	Sony 24" "Superwide" Monitor (Shown With Keyboard and Mouse) 111
Figure B-1	Main Circuit Wiring 118
Figure B-2	Correct and Incorrect Chassis Grounding Examples (Origin200 Systems Shown, Other Systems Similar) 120
Figure B-3	Chassis Branch Circuit Diagram for 120 VAC, 15 amp, 3-wire, 1-phase (U.S., Canada, and Japan) 121
Figure B-4	Chassis Branch Circuit Diagram for 230 VAC, 10 amp, 3-wire, 1-phase (International) 122
Figure B-5	Chassis Branch Circuit Diagram for 120 VAC, 20 amp, 3-wire, 1-phase (U.S. and Canada) 123
Figure B-6	Chassis Branch Circuit Diagram for 208 VAC, 20 amp, 3-wire, 1-phase (U.S., Canada, and Japan) 124
Figure B-7	Chassis Branch Circuit Diagram for 230 VAC, 16 amp, 3-wire, 1-phase (International) 125
Figure B-8	Chassis Branch Circuit Diagram for 208 VAC, 30 amp, 3-wire, 1-phase (U.S., Canada, and Japan) 127
Figure B-9	Chassis Branch Circuit Diagram for 230 VAC, 32 amp, 3-wire, 1-phase (International) 128
Figure B-10	O2, Octane, Origin200, Origin Vault, and Peripheral Power Cable, 125 VAC, 15 A (U.S., Canada, and Japan) 130
Figure B-11	O2, Octane, Origin200, Origin Vault, and Peripheral Power Cable, 250 VAC, 10 A (International) 131

- Figure B-12** Origin200 and Origin Vault Power Cable, 250 VAC, 15 A (For Rack PDU) 132
- Figure B-13** SGI 2000-Series Deskside and Onyx2 Deskside Power Cable, 125 VAC, 20 A (U.S. and Canada) 133
- Figure B-14** SGI 2000-Series Deskside and Onyx2 Deskside Power Cable, 250 VAC, 20 A (U.S., Canada, and Japan) 134
- Figure B-15** SGI 2000-Series Deskside and Onyx2 Deskside Power Cable, 250 VAC, 16 A (International) 135
- Figure B-16** SGI 2000-Series Base Module Power Cable, 250 VAC, 20 A (For Rack PDU) 136
- Figure B-17** Graphics Insert Module Power Cable, 250 VAC, 30 A (U.S., Canada, and Japan) 137
- Figure B-18** Graphics Insert Module Power Cable, 250 VAC, 32 A (International) 138
- Figure B-19** SGI 2000-Series and Onyx2 Rack Power Cable, 250 VAC, 30 A (U.S., Canada, and Japan) 140
- Figure B-20** SGI 2000-Series and Onyx2 Rack Power Cable, 250 VAC, 32 A (International) 141
- Figure B-21** Origin200 and Origin Vault Rack Power Cable, 250 VAC, 30 A (U.S., Canada, and Japan) 142
- Figure B-22** Origin200 and Origin Vault Rack Power Cable, 250 VAC, 32 A (International) 143

List of Tables

Table 1-1	Site Preparation Checklist	3
Table 1-2	Tools Useful for Receiving and Installing Systems	6
Table 2-1	U.S. Customary to Metric Conversions	24
Table 3-1	O2 Chassis Physical Specifications	30
Table 3-2	O2 Power and Cooling Specifications	31
Table 4-1	Octane Chassis Physical Specifications	37
Table 4-2	Octane Power and Cooling Specifications	38
Table 5-1	Origin200 Chassis Physical Specifications	47
Table 5-2	Origin200 Power and Cooling Specifications	48
Table 5-3	Origin Vault Physical Specifications	51
Table 5-4	Origin Vault Power and Cooling Specifications	52
Table 6-1	SGI 2000-Series Deskside and Onyx2 Deskside Minimum Airflow Clearances	58
Table 6-2	SGI 2000-Series Deskside and Onyx2 Deskside Recommended Minimum Service Clearances	58
Table 6-3	SGI 2000-Series Base Module Physical Specifications	61
Table 6-4	Minimum Voltage Requirements for SGI 2000-Series Deskside Systems	63
Table 6-5	SGI 2000-Series Base Module Power and Cooling Specifications	63
Table 6-6	Onyx2 Deskside System Physical Specifications	65
Table 6-7	Minimum Voltage Requirements for Onyx2 Deskside Systems	67
Table 6-8	Onyx2 Deskside System Power and Cooling Specifications	68
Table 7-1	Onyx2 Graphics Insert Module Physical Specifications	74
Table 7-2	Onyx2 Graphics Insert Module Power and Cooling Specifications	76
Table 8-1	SGI 2000-Series Rack Physical Specifications	97
Table 8-2	SGI 2000-Series Rack Power and Cooling Specifications	99
Table 8-3	Origin Peripherals Rack Physical Specifications	101
Table 8-4	Origin Peripherals Rack Power and Cooling Specifications	103

Table 8-5	Onyx2 Rack Physical Specifications	105
Table 8-6	Onyx2 Rack Power and Cooling Specifications	107
Table A-1	Monitor Physical Specifications	110
Table B-1	Power Cable and Connector Specifications	129
Table B-2	O2, Octane, Origin200, Origin Vault, and Peripheral Power Cable, 125 VAC, 15 A (U.S., Canada, and Japan)	130
Table B-3	O2, Octane, Origin200, Origin Vault, and Peripheral Power Cable, 250 VAC, 10 A (International)	131
Table B-4	Origin200 and Origin Vault Power Cable, 250 VAC, 15 A (For Rack PDU)	132
Table B-5	SGI 2000-Series Deskside and Onyx2 Deskside Power Cable, 125 VAC, 20 A (U.S. and Canada)	133
Table B-6	SGI 2000-Series Deskside and Onyx2 Deskside Power Cable, 250 VAC, 20 A (U.S., Canada, and Japan)	134
Table B-7	SGI 2000-Series Deskside and Onyx2 Deskside Power Cable, 250 VAC, 16 A (International)	135
Table B-8	SGI 2000-Series Base Module Power Cable, 250 VAC, 20 A (For Rack PDU)	136
Table B-9	Graphics Insert Module Power Cable, 250 VAC, 30 A (U.S., Canada, and Japan)	137
Table B-10	Graphics Insert Module Power Cable, 250 VAC, 32 A (International)	138
Table B-11	SGI 2000-Series and Onyx2 Rack Power Cable, 250 VAC, 30 A (U.S., Canada, and Japan)	140
Table B-12	SGI 2000-Series and Onyx2 Rack Power Cable, 250 VAC, 32 A (International)	141
Table B-13	Origin200 and Origin Vault Rack Power Cable, 250 VAC, 30 A (U.S., Canada, and Japan)	142
Table B-14	Origin200 and Origin Vault Rack Power Cable, 250 VAC, 32 A (International)	143

About This Guide

This guide presents the information system support engineers (SSEs), site personnel, and other interested parties need to know in order to prepare a customer site for the arrival of a Silicon Graphics O2 or Octane workstation, an SGI Origin200 server, Origin Vault expansion unit, Origin2000 server, or SGI 2000-series server, or a Silicon Graphics Onyx2 system.

In this guide, the term “SGI 2000-series” is used to refer to SGI Origin2000, SGI 2100, SGI 2200, SGI 2400, and SGI 2800 server systems.

Guide Organization

This guide contains the following sections:

- This section, “About This Guide,” describes the purpose of the guide, gives an overview of the guide’s structure, outlines the SGI product line, tells where to find related documents that may be helpful during site preparation and system installation, and gives contact information.
- Chapter 1, “Planning the Installation,” details the planning process recommended to ensure a smooth system installation and provides a checklist to ensure that essential tasks are completed.
- Chapter 2, “Site Preparation Concepts,” provides background information helpful in the planning process and addresses issues common to all SGI chassis.
- Chapter 3, “Site Preparation for O2 Systems,” contains information about selecting a location for a Silicon Graphics O2 system and provides detailed specifications for the chassis.
- Chapter 4, “Site Preparation for Octane,” contains information about selecting a location for a Silicon Graphics Octane system and provides detailed specifications for the chassis.

- Chapter 5, “Site Preparation for Origin200 and Origin Vault,” contains information about selecting a location for an SGI Origin200 system or Origin Vault peripheral unit and provides detailed specifications for both chassis.
- Chapter 6, “Site Preparation for SGI 2000-Series and Onyx2 Base Modules and Deskside Systems,” contains information about selecting a location for an SGI 2000-series or Onyx2 base module or deskside and provides detailed specifications for both chassis.
- Chapter 7, “Site Preparation for Onyx2 Graphics Insert Modules,” contains information about selecting a location for a Silicon Graphics Onyx2 Graphics Insert Module (an expansion chassis used only in Onyx2 rack systems) and provides detailed specifications for the module.
- Chapter 8, “Site Preparation for SGI 2000-series, Origin Peripherals, and Onyx2 Rack Chassis,” contains information about selecting a location for an SGI 2000-series, Origin Peripheral, or Onyx2 rack-chassis system and provides detailed specifications for single- and multi-rack installations.
- Appendix A, “Site Preparation for External Peripherals,” details the site-preparation considerations for the external peripherals used with the systems described in this guide.
- Appendix B, “Site Power and Power Cables,” provides information about site wiring and chassis power cables for the systems described in this guide.
- Appendix C, “Safety and Protection Equipment,” provides information and recommendations about safety and protection equipment for use with systems described in this guide.
- An index completes this guide.

The SGI Product Line

This book addresses SGI 2000-series, Origin Peripheral, and Onyx2 rack systems, SGI 2000-series and Onyx2 deskside systems, Origin200 and Origin Vault tower systems, Octane workstations, and O2 workstations, each in its own chapter. The beginning of each of these chapters contains information common to all chassis within that family. The subsequent subsections provide information for each variant of that chassis.

Use the information in the chassis-specific chapters in conjunction with that in Chapter 2 and in the appendices.

This document covers the following SGI chassis families:

- SGI 2000-series and Onyx2 rack chassis—These systems use the SGI 2000-series base modules and the Onyx2 graphics insert modules, both described below. Available in configurations containing from one rack to eight or more racks, these are highly powerful, highly expandable systems.
- SGI 2000-series and Onyx2 base module—Sometimes called the deskside chassis, this is the “little sibling” to the rack systems. While using the same powerful subsystems as the rack chassis, the deskside chassis is smaller, lighter, easier to transport, and lower in cost.
- Onyx2 graphics insert module—A rack-mounted expansion chassis designed to hold graphics boards and to be connected to an SGI 2000-series base module.
- Origin200—A server system optimized for small- to medium-sized enterprise file-serving, compute-serving, and Web-serving tasks. The Origin200 chassis is also used for the Origin Vault, a storage expansion unit.
- Octane—A powerful, graphics-intensive workstation, the Octane is designed for the most complex graphics tasks.
- O2—An affordable, high-performance workstation, suitable for many of today’s demanding tasks.

Additional Documentation

Additional documentation, which may be helpful during and after the installation process, is available from the SGI Technical Publications Library:

<http://techpubs.sgi.com/>

Reader Comments

If you have comments about the technical accuracy, content, or organization of this document, please tell us. Be sure to include the title and document number of the manual with your comments. (Online, the document number is located in the frontmatter of the manual. In printed manuals, the document number can be found on the back cover.)

You can contact us in any of the following ways:

- Send e-mail to the following address:
techpubs@sgi.com
- Use the Feedback option on the Technical Publications Library World Wide Web page:
<http://techpubs.sgi.com>
- Contact your customer service representative and ask that an incident be filed in the SGI incident tracking system.
- Send mail to the following address:
Technical Publications
SGI
1600 Amphitheatre Pkwy., M/S 535
Mountain View, California 94043-1351
- Send a fax to the attention of "Technical Publications" at +1 650 932 0801.

We value your comments and will respond to them promptly.

Planning the Installation

This chapter contains a checklist of the activities required to prepare for the arrival and installation of an SGI computer system, followed by details of the checklist items.

Some installations are simple enough that it isn't necessary to explicitly go through all the actions in the checklist. In other installations, the checklist can help you to organize the many tasks that need attention. Those responsible for the installation must decide into which category their particular installation fits.

For a detailed discussion of most of the items mentioned in this chapter, refer to Chapter 2, "Site Preparation Concepts," and to the chassis-specific chapters (chapters 3 through 8).

Organizing Activities

This chapter provides a step-by-step process to help you organize complex installations.

Read this chapter for an overview of site preparation activities, and then use Table 1-1 to track progress for your particular location and system. The rest of this guide provides specific details, many of which are relevant to the installation.

The extent of site preparation tasks depends on the size and complexity of the system. A few small systems are easily installed with little or no modification to the existing site. Large systems, or numerous small systems, require more preparation, with their greater requirements for power, air conditioning, and so on. When installing a system, keep in mind how it fits in with the rest of the equipment installed at that site.

Some sites require that you have specialized knowledge to plan and install services such as power, air conditioning, and safety equipment. Always follow local and regional codes and recommendations while performing activities under regulation. When using consultants, verify that they are licensed and knowledgeable about local regulations.

Site preparation also involves thinking about the future. As configurations grow, site requirements change. While planning a site, consider how and when the site will need modification, and plan accordingly. Make sure the infrastructure being installed (power, air conditioning, and so on) can support future expansion plans.

To minimize mistakes and unforeseen situations for complex sites, assign one person as a coordinator to read this guide and assign tasks. Table 1-1 is only a guideline and cannot cover all circumstances involved in site preparation. Also, many activities are interdependent and involve compromises. After the coordinator evaluates the dependencies and compromises, this guide can be divided among several people so that multiple activities can be performed at the same time.

Start with the activities that take the longest time. Pay particular attention to activities that involve dependency on others, such as having an electrician install power circuits, and to items that are expensive to change in the future.

When you have completed the activities outlined in Table 1-1, the site is prepared and is ready to receive the system. To proceed, refer to the installation instructions provided for the system. See "Additional Documentation" on page xix for the source of additional documents.

Site Preparation Checklist

See "Site Preparation Checklist Details" on page 4 for details about these items.

Table 1-1 Site Preparation Checklist

Activities	Date Completed	Notes
Verify intended site	__/__/__	
Physical	__/__/__	
EMI, ESD, vibration, acoustics	__/__/__	
Install power and air conditioning	__/__/__	
Determine power requirements	__/__/__	
Read grounding section (page 119)	__/__/__	
Install power circuits (if required)	__/__/__	
Install safety and protection equipment	__/__/__	
Determine thermal load	__/__/__	
Install air conditioning (if required)	__/__/__	
Prepare physical location	__/__/__	
System chassis	__/__/__	
Terminal, monitor, keyboard, mouse	__/__/__	
Prepare to receive shipment	__/__/__	
Determine size & weight of items	__/__/__	
Locate required tools (see Table 1-2)	__/__/__	
Arrange assistance to move large items	__/__/__	
Prepare for external cabling	__/__/__	
CrayLink	__/__/__	
Serial terminals and/or video monitors	__/__/__	
Keyboards and mice	__/__/__	

Table 1-1 (continued) Site Preparation Checklist

Activities	Date Completed	Notes
SCSI devices	__/__/__	
External networks	__/__/__	
Serial devices	__/__/__	
Parallel devices	__/__/__	

Site Preparation Checklist Details

This section provides additional details about the items in Table 1-1, and gives references to sources of further information.

Verify Intended Site

- Make sure the system can be safely transported to the intended site, and that it will fit once it gets there. Refer to “Physical Location” on page 10 and the individual chassis chapters (chapters 3 through 8) for detailed site requirements.
- Make sure the intended site does not have any unusual EMI or ESD problems. See “Electromagnetic Interference” and “Electrostatic Discharge” on page 20 for more information.
- Make sure that the intended site falls within the vibration limits for the system to be installed. Refer to the tables in the individual chassis chapters (chapters 3 through 8) to determine these limits. If the intended site exceeds these limits, take corrective action.
- Make sure the acoustic output of the planned installation does not present a problem. Refer to “Acoustics” on page 22 and the individual chassis chapters (chapters 3 through 8) to determine the acoustic output of the planned systems. If these totals present a problem, take corrective action.

Install Power and Air Conditioning

- Determine the power and wiring requirements of the site using the information supplied in “Electrical Requirements” on page 13, the individual chassis chapters (chapters 3 through 8), and Appendix B, “Site Power and Power Cables.”
- Read “Chassis Branch Circuit Grounding” on page 119 to ensure that the site fully meets the very important requirements described there.
- If the existing site wiring does not support the planned installation, arrange for the wiring to be upgraded.
- Read Appendix C, “Safety and Protection Equipment,” and install any necessary upgrades.
- Determine the air conditioning requirements (thermal load) for the site using the information supplied in “Thermal Requirements” on page 17 and in the individual chassis chapters (chapters 3 through 8).
- If the existing site air conditioning does not support the planned installation, arrange for the air conditioning to be upgraded.

Prepare Physical Location

- Arrange adequate space for the delivery and installation of the systems using the information supplied in “Physical Location” on page 10 and the shipping dimensions listed in the individual chassis chapters (chapters 3 through 8).
- Arrange for any required external peripherals, such as terminals, monitors, keyboards, mice, SCSI devices, and so on, using the information supplied in Appendix A, “Site Preparation for External Peripherals.”

Prepare to Receive Shipment

- Consider the size and weight of the shipping cartons listed in the individual chassis chapters (chapters 3 through 8), and make any necessary preparations to receive them. Also read “Physical Location” on page 10.
- Refer to Table 1-2 to determine the tools needed for each listed activity.

Table 1-2 Tools Useful for Receiving and Installing Systems

Activity	Chassis	Tools Required
Unloading crates	Deskside	Pallet jack with 22" fork spacing (up to 200 lb).
	Rack	Forklift (can require up to a 1,000-lb capacity).
Opening shipping cartons or crates	Deskside	Knife (to cut strapping bands).
	Rack	Gloves (protection from crate splinters). Wrench, 7/16" or adjustable.
	Monitor, destination kit	Knife (to cut packing tape).
Moving system		Low-profile dolly that keeps chassis vertical; moving blankets or wraps.
Installing chassis		Usually no tools are required. Addition of optional components may require 7/64" allen wrench or medium slothead and cross-recess screwdrivers.
Stabilizing chassis (seismic protection)	Deskside	Stabilizers to screw into 1/4"-20 UNC threads on chassis underside.
	Rack	Stabilizers to replace leveler feet in M12 x 1.75 threads on chassis underside.
Connecting cables		Small slothead and cross-recess screwdrivers.

- Arrange for assistance moving large items. In particular, assistance is recommended when
 - receiving a large shipment
 - uncrating a rack chassis
 - moving a rack chassis.

Caution: Always use assistance when moving equipment up or down ramps. For rack systems, use a minimum of three individuals. On fully configured systems, up to five people may be required to move the chassis safely. Avoid ramps that exceed a 20° angle.

Prepare for External Cabling

Read the individual chassis chapters (chapters 3 through 8) to determine which local devices may be installed, then make any necessary arrangements. Also see Appendix A, “Site Preparation for External Peripherals.”

Site Preparation Concepts

This chapter provides a general overview of the planning process, and provides a more detailed discussion of the issues involved in the site preparation than is provided in the individual chassis chapters (chapters 3 through 8).

Not all of the items listed here apply to every installation. For example, if the system being installed is a single small workstation, the delivery route probably does not present a problem. However, it is a good idea to at least briefly consider each question for any system installation.

Chapter 1 of this guide provides a checklist for site preparation. Chapters 3 through 8 provide detailed specifications for each chassis described. This chapter provides the theory behind the checklist and system specifications. It explains what the specifications mean, and why they are important.

Physical Location

This section addresses the issues to consider when choosing a physical location for a new system.

Selecting a Delivery Route

The best final location is no good if you can't get the system there. Answer the following questions before planning a delivery route for the new system:

- Will the packing crate fit through doorways and hallways and on elevators?

The relevant dimensions can be found in chapters 3 through 8. Just measuring the width of the halls, for example, is not enough. Look for corners where the system might get stuck, check width and height of doorways and elevators, and so on.

- If the packing crate can't be transported to the final destination, can you unpack the system somewhere else?

Often it is possible to unpack the system in a hallway or on a loading dock, then roll the system to its final destination.

- Is the floor strong enough?

The rack systems can be very heavy. Look up the floor loading figures in chapters 3 through 8 and verify that the floor along the delivery route can handle the weight.

- Is the elevator capable of lifting the system?

If the intended delivery route includes an elevator, check its weight capacity and size against the system specifications detailed in chapters 3 through 8. If they are available, use freight blankets on elevator sides. Use straps to keep the chassis from shifting while being moved in an elevator.

- Are there any steep angles, bumps, sharp changes in level, or thick carpeting along the delivery route?

The large systems are equipped with wheels. However, the wheels are designed only for relatively smooth, level surfaces. Ramps, sliding door channels, rough flooring, and even thick carpeting may present difficulty. If in doubt, arrange for additional assistance.

- Did you check that the leveling feet are fully retracted?

Caution: Some systems have screw-in leveling feet. Moving the system with these feet extended can cause severe damage to the chassis. These feet sometimes unscrew during shipment. Before unpacking or moving a system, ensure that the leveling feet are fully retracted.

Selecting a Final Location

There are a number of issues to consider when selecting a location for the system. Answer the following questions before selecting a final location for the new system.

- Will the system interfere with normal traffic through aisles, hallways, or entranceways in the intended location?
- Will the intended location allow the convenient performance of routine operations, such as loading and unloading tapes or other media, attaching cables, and so on?
- Is the floor of the intended site strong enough to support the system, and any planned future expansions?

Large systems are often installed in machine rooms with raised floors. Pay particular attention to floor-loading and weight distribution in this case.

The floor loadings listed in the tables in chapters 6 and 8 are total chassis weights averaged over the chassis's entire footprint. Since the chassis typically sit on four casters or four levelers, the point loading is drastically higher.

- Will the system fit in its intended location?

Refer to the relevant section of chapters 3 through 8 for system dimensions.

- Will the systems be maintainable?

Even if it fits, the system must still be maintainable. Using the measurements provided in chapters 3 through 8, make sure you will have enough room to open the doors, remove boards, and accomplish other routine tasks.

- How does the intended location fit with future expansion plans for the site?

- Is the location subject to flooding, extremes of humidity or temperature, or any other factor making it inappropriate for sensitive electronic equipment?

Generally speaking, SGI systems are designed for use in typical office computing environments: the air temperature should not be too high and should not fluctuate dramatically, air should circulate freely, and it should be relatively dust-free, and the system should not be exposed to any caustic or corrosive chemicals or vapors. Refer to the environmental specifications listed in the appropriate tables in chapters 3 through 8 for details.

Electrical Requirements

Some SGI systems require electrical resources beyond what may be found in a typical office environment. The following sections describe those requirements in general. These sections, along with the data presented in chapters 3 through 8, can help to determine the exact requirements for the new system.

Voltage Requirements

- What voltage does the system require?

SGI systems may be shipped with many different voltage configurations. Even some of the smaller systems may require 208 volts, which may need to be specially installed at the site. Refer to the “Power and Cooling” table in the relevant section of chapters 3 through 8 for the voltage requirements of the chassis in question.

- Is the required voltage available?

Make sure that the required voltage is available, and is within a reasonable distance of the intended location. If it is not, the site will need to be wired for the required voltage.

Different voltages are available in different countries. Japan uses a low voltage of 100 volts and a high voltage of 200 volts. The United States and Canada use a low voltage of 120 volts and high voltages of either 208 volts or 240 volts. Some other countries use 220 volts or 240 volts, but many have now switched to a 230-volt standard.

In this book, “120 volts” is used to refer to the low range (and, except where otherwise indicated, includes Japan’s 100 volts), and 208 is used to refer to the high range (and, except where otherwise indicated, includes Japan’s 200 volts, as well as the 220 volts, 230 volts, and 240 volts used in various other countries).

Power Requirements

- Is there enough power for the system?

Even one SGI system can require more power than is routinely available in an office environment. A roomful of them will almost certainly require some specially installed electrical circuits. Refer to the “Power and Cooling” table in the relevant section of chapters 3 through 8 for the power requirements of the chassis in question.

Note: Most configurations will never draw the wattages listed as “maximum” in this guide. However, it is generally a good practice to install wiring capable of supporting the system’s maximum potential wattage. If you need power figures for your specific configuration, ask your SGI representative.

Power is measured in volt-amps (VA) and in watts. Both numbers are important in preparing wiring, power conditioning, and cooling.

A system’s VA rating is a function of the voltage and amperage of a system. A system’s watt rating is that system’s VA rating multiplied by its power factor (see “Power Factor” on page 15). You can convert among amps, volts, VA, power factor, and watts using the following formulas:

$$\begin{aligned} \text{VA} &= \text{amps} \times \text{volts} \\ \text{VA} &= \text{watts} \div \text{power factor} \\ \text{watts} &= \text{VA} \times \text{power factor} \\ \text{amps} &= \text{watts} \div (\text{volts} \times \text{power factor}) \end{aligned}$$

Using this information and the information provided in the “Power and Cooling” tables in the relevant sections of chapters 3 through 8, you can determine the site power requirements.

If, after adding up the power requirements of all the devices in the room, you find that the total is even close to the limit of what the existing wiring can support, you should probably install additional power circuits to support the systems.

Grounding Requirements

- Will all the chassis be at the same ground potential?



Warning: Any difference in ground potential greater than 500 millivolts (0.5 volts) between two chassis connected with CrayLink or XTown cables can cause severe equipment damage. For further information, see “Chassis Branch Circuit Grounding” on page 119.

Power Factor

The “Power and Cooling” tables in chapters 3 through 8 include a listing for power factor. “Power factor” is a number between zero and one representing the portion of the power drawn by a system that actually delivers energy to the system. A system with a power factor of one (sometimes called “unity” power factor) is making full use of the energy it draws. A system with a power factor of 0.75 is effectively using only three-quarters of the energy it draws.

Many SGI systems are power-factor corrected, and thus have a power-factor of one, or very close to one. Some SGI systems and peripherals do not have this correction built in.

Caution: It is very important when selecting an uninterruptible power supply (UPS) or standby power supply (SPS) to take the system’s power factor into account. For more information, refer to “Power-Line Treatment” on page 147.

Inrush Current

The “Power and Cooling” tables in chapters 3 through 8 include a listing for inrush current. “Inrush current” is the peak current that flows into a power supply as AC power is applied. The inrush current is usually much higher than the nominal current. This temporary increase is due to the charging of the input filter capacitors in the power supply, and is limited only by the input impedance of the power supply and the wiring supplying power to the system.

The inrush current often far exceeds the rating of the electrical outlet to which the system is connected. If the system is connected directly to “wall power” (that is, it is not on a UPS or SPS), this is typically not a problem. The peak inrush current lasts for only a part of one AC cycle (that is, less than 1/60 of a second). This is not long enough to damage wiring, and in most cases will not trip a circuit breaker (though this depends on the delay curves of the circuit breaker).

Caution: It is very important when selecting a UPS or SPS to take the system’s inrush current into account. Unlike power-company lines, these power-protection devices may not be able to supply the current required during power-on, even if they are sized appropriately for nominal current loads. For more information, refer to “Power-Line Treatment” on page 147.

It is possible for the inrush current drawn by a device to cause a slight drop in the line voltage. Though it is very brief, this drop can, in unusual situations, be enough to cause problems in other devices on the same line.

Inrush current is a characteristic of the power supply (or supplies) in a system. The inrush current values listed in the “Power and Cooling” tables in chapters 3 through 8 apply whether the system is heavily or lightly loaded. Therefore, though a lightly loaded system may draw less power while it is running, it may still draw a very large inrush current at the moment it is powered on.

Total Harmonic Distortion

The “Power and Cooling” tables in chapters 3 through 8 include a listing for total harmonic distortion (THD). Total harmonic distortion (sometimes also called harmonic factor) is a measure of the extent to which a waveform is distorted by harmonic content. This rating tells how much the power supply in the system affects the quality of power delivered to other systems supplied by the same transformer.

While the term total harmonic distortion can be applied to either voltage or current, the figures listed in this guide all apply to current.

Thermal Requirements

It is important that SGI systems be kept within their rated thermal range.

- Will the ambient air temperature surrounding the system be within the required range?

Refer to the “Power and Cooling” table in the relevant section of chapters 3 through 8 for temperature ranges for the chassis in question. Typically, the upper limit of the temperature range is more likely to be an issue than the lower limit.

Heat Output

All of the systems detailed in this guide have a maximum rated operating temperature. Exceeding this temperature greatly increases the rate of hardware failure, and in many cases causes the system to simply shut itself down.

All the electrical power consumed by a computer system must end up somewhere. For ordinary air-cooled systems, the place it ends up is in the surrounding air, in the form of heat. Every watt drawn by a system is eventually dissipated as heat. This tends to raise the temperature of the air in the room that houses the system. Some method is therefore needed to keep the temperature within the required range. The typical method is to install additional air conditioning capacity.

Air Conditioner Terminology

Air conditioner capacity is generally measured in Btu per hour (Btu/hr), in tons, or in KiloJoules per hour (KJoule/hr).

A Btu, or British thermal unit, is the amount of energy needed to change the temperature of one pound of water by one degree Fahrenheit.

One ton of air conditioning removes 12,000 Btu of heat energy per hour.

One KJoule is the amount of work or energy equal to 1×10^{10} ergs, or one watt-second.

The more systems installed in a given area, the larger the air conditioning capacity required. It is important to calculate the total thermal load of the computer systems you will be installing and determine if the existing air conditioning system can handle the additional load. If not, you must provide additional cooling capacity.

Calculating Thermal Load

The thermal load can be determined as follows:

- Add up the wattages of all the items in the room.
- Calculate Btu/hour by multiplying the total wattage by 3.41.
- Calculate the KJoules/hour by multiplying the total wattage by 3.23.
- Calculate tons of air conditioner load by multiplying wattage by 0.000285
1 KBtu/hr = 1000 Btu/hr
12,000 Btu/hr = 1 ton of air conditioning load

Caution: The calculations described here give results that represent the equipment's theoretical maximum thermal output. These calculations, and the "maximum" thermal figures given in the individual chassis chapters (chapters 3 through 8), are based on maximum rated wattage. Even if a system approaches this maximum rated wattage occasionally, it is highly unlikely it will do so for very long. For these reasons, **the "maximum" thermal figures quoted in this guide are truly worst-case figures.**

Some sources quote "typical" thermal outputs, which may be significantly lower than the numbers listed in this guide. Sizing the air conditioning system for "worst-case" thermal output, however, helps to minimize system problems later. If these maximum thermal figures represent a problem for your site, or if you have any other concerns about these figures, talk to your SGI representative.

When calculating required air conditioner capacity be sure to take into account not only the heat load from computer equipment already installed at the site, but also the non-computer equipment already installed or to be installed, and other factors, such as solar gain, outside ambient air temperatures, and even the number of people. Besides the computer equipment being added to a site

Thermal Gradient

The “Specifications” tables in chapters 3 through 8 include a maximum thermal gradient for each system. The thermal gradient is the rate at which the temperature changes, typically given in degrees per hour. Temperature changes that are more rapid than the given rating can cause damage to some of the components used in the systems.

Where not otherwise indicated, the thermal gradients listed apply whether or not the system is operating.

Cooling In Mission-Critical Installations

In mission-critical installations it is important to consider what would happen in the event of an air conditioner failure. Complete consideration of this topic is beyond the scope of this book. It would be a good idea, however, to consider the following:

- Should the site have multiple air conditioning units, each able to maintain a safe temperature?
- How long can the site run in the event of an air conditioner failure before the systems get too warm, and must be shut off?

Can the air conditioner be repaired within this time?

Environmental Requirements

Electromagnetic interference (EMI), electrostatic discharge (ESD), vibration, and humidity can cause problems for computer systems.

Electromagnetic Interference

Electromagnetic interference (EMI) is caused by malfunctioning, incorrectly manufactured, or incorrectly installed devices that radiate electrical signals. Common sources of EMI include electronic, telephone, and communications equipment. EMI transmissions can be conducted or emitted.

Use properly shielded connectors and cables throughout the site to prevent the new systems from generating EMI.

Caution: Failure to use shielded cables where appropriate may violate FCC regulations and void the manufacturer's warranty.

Electrostatic Discharge

SGI designs and tests its products to be resistant to the effects of electrostatic discharge (ESD). However, it is still possible for ESD to cause problems ranging from data errors and lockups to permanent component damage. To protect the systems from ESD, use these precautions:

- Minimize the use of carpeting at computer locations (or consider special static-reducing carpet).
- Verify that all electronic devices are properly grounded.
- Keep all chassis doors and access panels closed while the system is in operation.
- Keep all screws, thumbnail-fasteners, and slide-locks fastened securely.
- Use a grounded static wrist strap whenever working with the chassis or components.
- Use antistatic packing material for storage and transportation.
- Clear the site of all devices that create static electricity or are possible sources of EMI.

Vibration

The SGI product line is designed for use in a typical office computing environment, requiring no special modifications or protection. If a system is to be installed at an industrial site, ensure that vibration does not exceed the limits given in the relevant “Specifications” table in chapters 3 through 8.

Humidity

The “Specifications” tables in chapters 3 through 8 include a listing for maximum humidity levels for each system, both operating and non-operating. Exposure to humidity levels above the rated maximums, or exposure to condensation, can cause equipment damage.

Humidity Gradient

The tables in chapters 5 through 8 include a maximum humidity gradient for each system. The humidity gradient is the rate at which the humidity changes, typically listed in percent relative humidity per hour. Humidity changes that are more rapid than the given rating can cause damage to some of the components used in the systems.

Where not otherwise indicated, the humidity gradients listed apply whether or not the system is operating.

Ergonomic Requirements

In selecting a physical location, pay attention to ergonomic considerations. The location of a system often puts constraints on the location of the devices attached to it, such as monitors, keyboards, and so on. In this way, decisions made during the installation process can affect workers much later.

In addition to attached devices, consider issues of noise, temperature, air quality, and so on, some of which may be affected by the addition of the new system.

Acoustics

All of the acoustic measurements provided in this book are in dBa (decibels absolute) rather than dB (decibels). This is a measurement of weighted absolute noise power, and includes frequency corrections.

The acoustic measurements listed in chapters 5 through 8 are approximate. Acoustic values depend on many factors outside the control of the manufacturer. Room characteristics such as carpeting and wall coverings affect the noise levels at an installation.

If a site exceeds desirable noise levels, try these remedies:

- Try alternate orientations of the systems (for example, point the fan away from people).
- Reduce the quantity of flat reflective surfaces, such as glass, tile, or metal.
- Add sound-absorbing carpet, wall coverings, and drapes.
- Add sound baffles in critical locations (being careful not to block airflow).
- Install ceiling tiles with sound-absorbing properties.
- Modify office space to separate operators from hardware.

Local Regulations

Before installing a system, make sure to become familiar with any applicable local regulations. Since these vary dramatically by country and state, it is impossible to provide a complete list of such regulations. These regulations, however, might involve

- power
- emissions
- other safety issues
- ergonomic and health issues
- telecommunications regulations.

Planning for the Future

- Will additional systems be added to the site in the future?

Even if the infrastructure in place can handle the site's immediate needs, what are the future plans? It is always much easier to provide enough space, power, air conditioning capacity, and so on, in advance than it is to add them later.

Converting Between U.S. Customary Measure and Metric Measure

Table 2-1 contains a list of conversions between U.S. Customary measure and Metric measure.

Table 2-1 U.S. Customary to Metric Conversions

U.S. Customary	Metric
1 inch (")	2.54 cm
1 foot (')	30.48 cm
1 square foot (ft ²)	0.093 m ²
1 pound (lb)	0.4536 kg
1 lb/ft ²	4.88 kg/m ²
1 cfm	0.00047 m ³ /s
1 Btu	1055 Joules
1 Btu	1.055 KJoules
0.3937"	1 cm
39.37"	1 m
10.76 ft ²	1 m ²
2.205 lbs	1 kg
0.205 lb/ft ²	1 kg/m ²
2127.66 cfm	1 m ³ /s
0.00095 Btu	1 Joule
0.95 Btu	1 KJoule

Fahrenheit to Celsius conversion

$$(F^{\circ} - 32^{\circ}) \times 5/9 = C^{\circ}$$

Start with the temperature in Fahrenheit, subtract 32 degrees, multiply by 5, and divide by 9. The result is the temperature in Celsius.

Celsius to Fahrenheit conversion

$$(C^{\circ} \times 9/5) + 32^{\circ} = F^{\circ}$$

Start with the temperature in Celsius, multiply by 9, divide by 5, and add 32 degrees. The result is the temperature in Fahrenheit.

Site Preparation for O2 Systems

The O2 chassis provides an affordable, high-performance graphic workstation, suitable for many of today's most demanding tasks.

Selecting a Location for an O2 System

Silicon Graphics O2 systems are designed to be located on a desktop. Figure 3-1 shows an O2 system in a typical configuration.

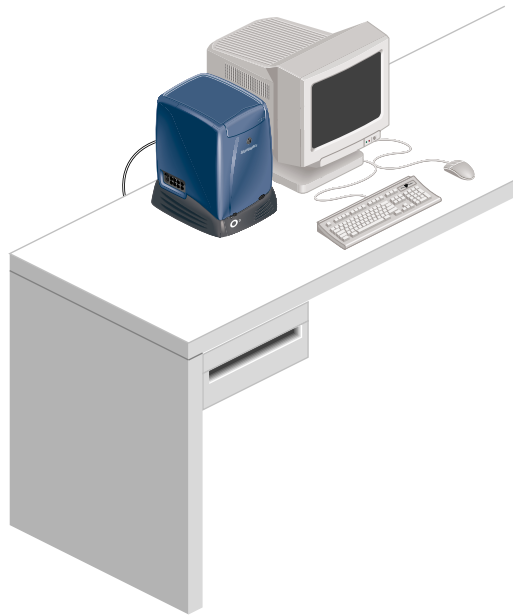

Figure 3-1 O2 Typical Configuration

Figure 3-2 shows the airflow path in O2 systems. The white arrows show the air intake areas on both sides of the system. The side with three arrows has more airflow than the side with one arrow. The darker arrows show the air exhaust area at the rear of the system. Be sure that the location selected allows free flow of air to and from the areas shown.

O2 systems are designed for use in typical office computing environments: The air temperature should not fluctuate dramatically, air should circulate freely, and the location should be relatively dust free.

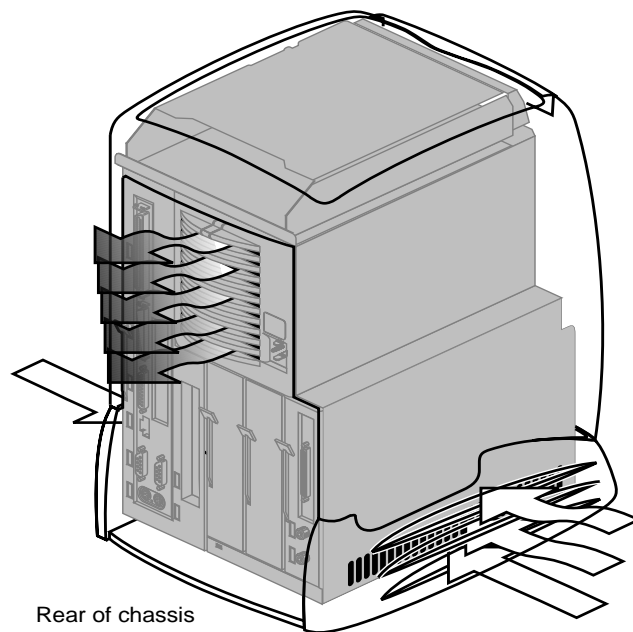

Figure 3-2 O2 Airflow

O2 Site Requirements

For information about selecting a physical location for an O2 system, see “Selecting a Location for an O2 System” on page 28.

O2 Specifications

Table 3-1 lists the physical specifications of the O2 chassis.

Table 3-1 O2 Chassis Physical Specifications

Dimensions		
Installed:	length	11.5" (29.2 cm)
	width	9" (22.9 cm)
	height	12.7" (32.3 cm)
In Packaging:	length	20.2" (51.3 cm)
	width	16.2" (41.2 cm)
	height	18.3" (46.5 cm)
Weight:	installed	20 lbs (9.1 kg)
	in packaging	30 lbs (13.6 kg)
Air Temperature:	operating	50° to 95° F (10° to 35° C)
	in packaging	-40° to 149° F (-40° to 65° C)
Thermal Gradient:	operating	18° F (10° C) per hour (maximum)
	in packaging	108° F (60° C) per hour (maximum)
Altitude:	operating	10,000 ft (3,048 m) MSL (maximum)
	in packaging	40,000 ft (12,192 m) MSL (maximum)

Table 3-1 (continued) O2 Chassis Physical Specifications

Relative Humidity:	operating	10-80% (non-condensing)
	in packaging	5-95% (non-condensing)
Vibration:	operating	0.02", 5-19Hz; 0.25 G, 19-100 Hz (maximum)
	in packaging	0.1", 5-19Hz; 0.5 G, 19-500 Hz (maximum)

O2 Power and Cooling Requirements

Table 3-2 provides power consumption and required cooling capacity information for the O2 system. For formulas, descriptions, and general information about power and cooling, refer to "Electrical Requirements" on page 13 and "Thermal Requirements" on page 17.

Caution: The power and cooling figures listed in Table 3-2 are maximums. Actual power and cooling requirements will vary, depending on configuration and load. Ask your SGI representative about particular configurations.

Table 3-2 O2 Power and Cooling Specifications

Volts:		100-120 volts AC, 1-phase 200-240 volts AC, 1-phase
Watts (from-the-wall):	maximum	245 watts (see "Caution," above)
Power Factor:	minimum	0.96
Total Harmonic Dist.:	at 120 volts	5% maximum
Inrush Current:	maximum	40 amps
Frequency:		47-63 Hz

Table 3-2 (continued) O2 Power and Cooling Specifications

Cooling Requirements: (Also see "Caution" on page 18)	maximum	835 Btu/hr (0.07-ton AC load) (see "Caution," above)
Airflow Volume:	maximum	37 cfm (0.017 m ³ /s)

See Appendix B, "Site Power and Power Cables," for information about O2 chassis site-wiring and power cables.

O2 External Peripherals

An O2 system typically has a monitor, a keyboard, and a mouse. For more information, see "Monitors" on page 109, "Keyboards" on page 112, and "Mice" on page 112.

An O2 system may also have one or more external SCSI devices attached to it. For small SCSI devices, see "External SCSI Devices" on page 112. Also see information about Origin Vault systems in "Origin Vault Site Requirements" on page 51.

O2 Cabling Issues

Besides power cables and external peripherals (mentioned above), O2 systems are typically wired to network cables, serial and parallel devices, and so on. For details of the ports found on an O2 workstation, see the *O2 Workstation Hardware Reference Guide*.

See Appendix B, "Site Power and Power Cables," for information about O2 chassis site-wiring and power cables.

Site Preparation for Octane

The Octane system is a powerful, graphics-intensive workstation, designed for the most complex of graphics tasks.

Octane systems are available with either single or dual MIPS processors.

Selecting a Location for an Octane System

Silicon Graphics Octane systems are designed to be located either on a desktop or beside a desk. Figure 4-1 shows an Octane system in a typical desktop configuration, and Figure 4-2 shows an Octane system in a typical deskside configuration.



Figure 4-1 Octane Typical Desktop Configuration

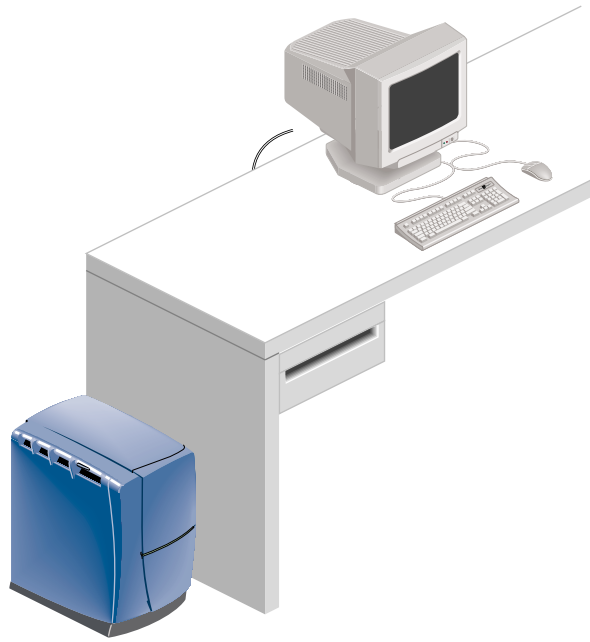

Figure 4-2 Octane Typical Deskside Configuration

Figure 4-3 shows the airflow path in Octane systems. The white arrows show the air intake areas on the top left, top right, top rear, and the front of the system. The darker arrow shows the air exhaust area at the rear of the system. Be sure that the location selected allows free flow of air to and from the areas shown.

Octane systems are designed for use in typical office computing environments: The air temperature should not fluctuate dramatically, air should circulate freely, and the location should be relatively dust free.

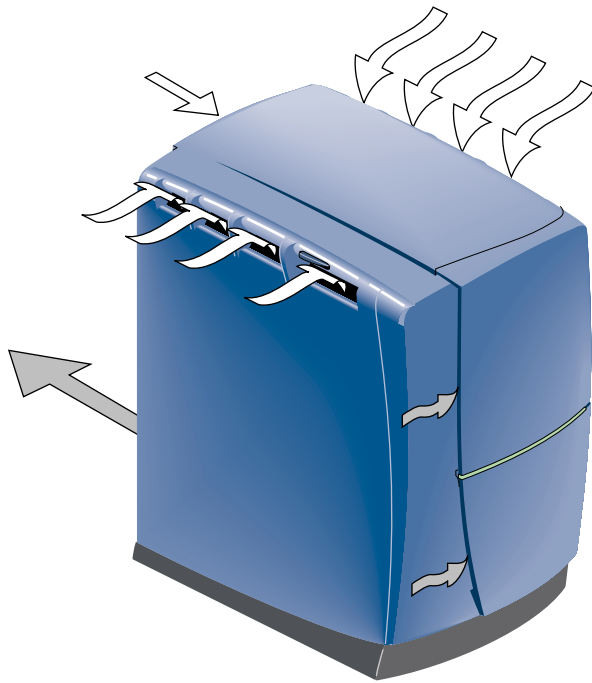

Figure 4-3 Octane Airflow

Octane Site Requirements

For information about selecting a physical location for an Octane system, see “Selecting a Location for an Octane System” on page 34.

Octane Specifications

Table 4-1 lists the physical specifications of the Octane chassis.

Table 4-1 Octane Chassis Physical Specifications

Dimensions		
Installed:	length	16.2" (41.2 cm)
	width	11.0" (28 cm)
	height	16.3" (41.4 cm)
In Packaging^a:	length	29.6" (75.2 cm)
	width	21.3" (54.1 cm)
	height	25.4" (64.5 cm)
Weight:	installed	72 lbs (32.7 kg)
	in packaging ^a	82 lbs (37.2 kg)
Air Temperature:	operating	50° to 95° F (10° to 35° C)
	in packaging ^a	14° to 149° F (-10° to 65° C)
Thermal Gradient:	operating	18° F (10° C) per hour (maximum)
	in packaging ^a	108° F (60° C) per hour (maximum)
Altitude:	operating	10,000 ft (3,048 m) MSL (maximum)
	in packaging ^a	40,000 ft (12,192 m) MSL (maximum)
Relative Humidity:	operating	10-80% (non-condensing)
	in packaging ^a	10-95% (non-condensing)
Vibration:	maximum	0.02", 5-19Hz; 0.35 G, 19-500 Hz

a. It is important that Octane systems be shipped only in their complete packaging, including the pallet.

Octane Power and Cooling Requirements

Table 4-2 provides power consumption and required cooling capacity information for the Octane system. For formulas, descriptions, and general information about power and cooling, refer to “Electrical Requirements” on page 13 and “Thermal Requirements” on page 17.

Caution: The power and cooling figures listed in Table 4-2 are maximums. Actual power and cooling requirements will vary, depending on configuration and load. Ask your SGI representative about particular configurations.

Table 4-2 Octane Power and Cooling Specifications

Volts:		100-120 volts AC, 1-phase 200-240 volts AC, 1-phase
Watts (from the wall):	maximum	850 watts (see “Caution,” above)
Power Factor:	minimum	0.98
Total Harmonic Dist.:	at 120 volts	5% maximum
Inrush Current:	peak	60 amps
Frequency:		47-63 Hz
Cooling Requirements: (Also see “Caution” on page 18)	maximum	2,899 Btu/hr (0.24-ton AC load) (see “Caution,” above)
Airflow Volume:	maximum	60 cfm (0.028 m ³ /s)

See Appendix B, “Site Power and Power Cables,” for information about Octane chassis site-wiring and power cables.

Octane External Peripherals

An Octane system typically has a one or more monitors, a keyboard, and a mouse. For more information, see “Monitors” on page 109, “Keyboards” on page 112, and “Mice” on page 112.

An Octane system may also have one or more external SCSI devices attached to it. For small SCSI devices, see “External SCSI Devices” on page 112. Also see information about Origin Vault systems in “Origin Vault Site Requirements” on page 51.

Octane Cabling Issues

Besides power cables and external peripherals (mentioned above), Octane systems are typically wired to network cables, serial and parallel devices, and so on. For details of the ports found on an Octane workstation, see the *Octane Workstation Owner’s Guide*.

See Appendix B, “Site Power and Power Cables,” for information about Octane chassis site-wiring and power cables.

Site Preparation for Origin200 and Origin Vault

The Origin200 and Origin Vault chassis provide a very high-performance computer system or peripherals expansion chassis in a compact tower-style or rack-mountable package.

A brief overview of these systems follows. While these descriptions are current as of the date of publication, please refer to the most recent SGI price book for the latest information.

- Origin200—A floor-standing or rack-mountable server offering from one to four processors in one or two chassis (one or two processors per chassis).
- Origin Vault—A floor-standing or rack-mountable SCSI peripherals module that may be used with O2, Octane, Origin200, Origin2000, or Onyx2 systems. It is included in this chapter due to its strong similarity to the Origin200 server chassis.

Note: For site preparation information about Origin 200 systems or Origin Vault modules mounted in an SGI Peripherals rack, see Chapter 8, “Site Preparation for SGI 2000-series, Origin Peripherals, and Onyx2 Rack Chassis.”

Selecting a Location for an Origin200 or Origin Vault System

SGI Origin200 and Origin Vault systems are designed to be located either upright (for example, beside a desk) or mounted in a 19-inch rack. The deskside configuration of the Origin200 and Origin Vault is sometimes called a tower configuration. Figure 5-1 and Figure 5-2 show the Origin200 or Origin Vault system in its deskside and rack-mountable configurations, respectively.

Feet on Origin200 and Origin Vault Systems

Origin200 and Origin Vault systems are shipped with feet, as shown in Figure 5-1. For use in a rack, the feet and skins are removed, as shown in Figure 5-2. To avoid tipping over the system, it is recommended that these feet be installed for any configuration in which the system is placed vertically.

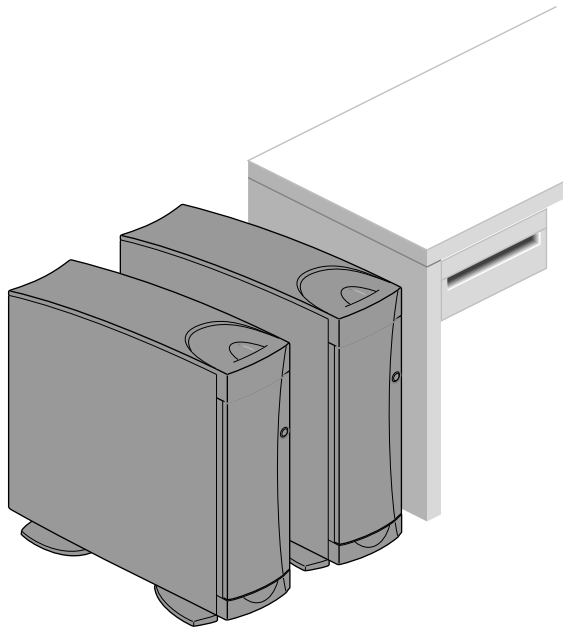

Figure 5-1 Origin200 and Origin Vault Deskside (Tower) Configuration (With Skins)

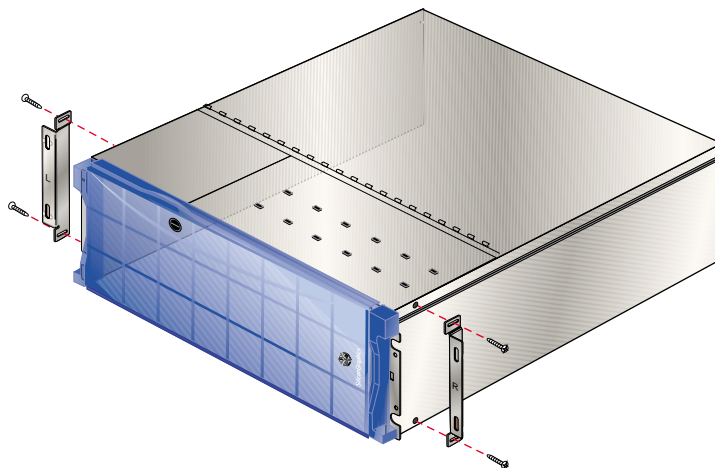

Figure 5-2 Origin200 and Origin Vault Rack-Mount Configuration and Mounting Hardware

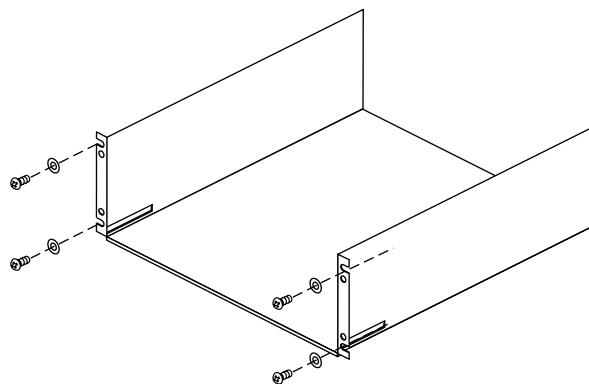

Figure 5-3 Origin200 and Origin Vault Rack Shelf and Mounting Hardware

Clearances for Origin200 and Origin Vault Systems

Figure 5-4 shows the required clearances for the Origin200 and Origin Vault chassis, both singly and in pairs. Clearance requirements on single chassis installations are for airflow.

Origin200 systems are designed to be connected with CrayLink cables, and an Origin200 system often has a companion Origin Vault chassis, which is connected with a SCSI cable. Clearance requirements for multiple chassis are thus based both on cabling and airflow issues.

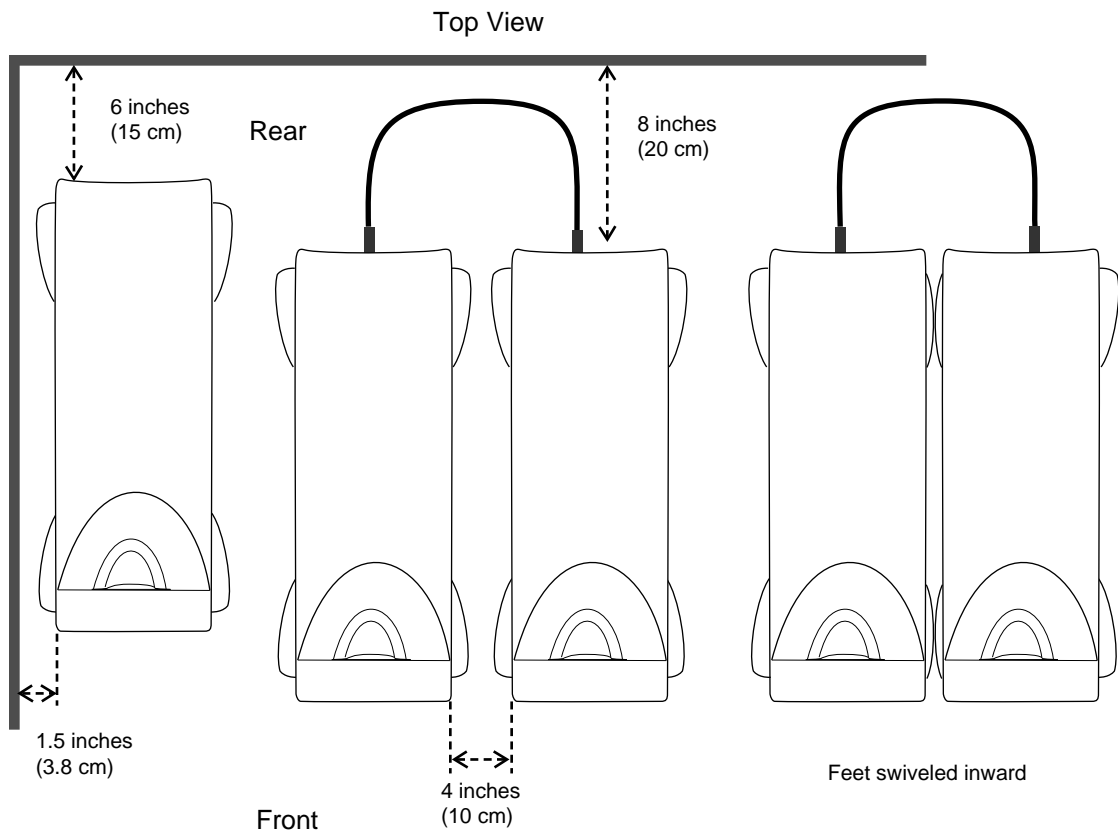

Figure 5-4 Origin200 and Origin Vault Chassis Clearances

Airflow in Origin200 and Origin Vault Systems

Figure 5-5 shows the airflow path in Origin200 and Origin Vault chassis. Be sure that the location selected allows free flow of air to and from the areas shown.

For an illustration of airflow in Origin200 or Origin Vault systems mounted in a rack chassis, see Figure 8-7.

Origin200 systems are designed for use in typical office computing environments. The air temperature should not fluctuate dramatically, air should circulate freely, and the location should be relatively dust free.

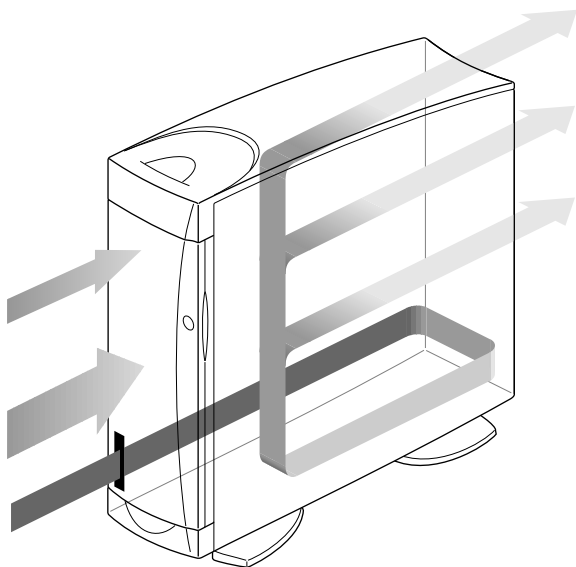

Figure 5-5 Origin200 and Origin Vault Airflow

Wiring and Grounding Requirements for Origin200 and Origin Vault Systems

Specific information about power requirements is provided in “Origin200 Power and Cooling Requirements” on page 48 and “Origin Vault Power and Cooling Requirements” on page 52.

Besides providing enough power for the systems, in the case of multiple Origin200 systems joined with CrayLink cables, there is an additional requirement: the ground potentials must be unusually close.



Warning: Any difference in ground potential greater than 500 millivolts (0.5 volts) between two chassis connected with CrayLink or XTown cables can cause severe equipment damage. For further information, see “Chassis Branch Circuit Grounding” on page 119.

Origin200 Site Requirements

For information about selecting a physical location for an Origin200 system, see “Selecting a Location for an Origin200 or Origin Vault System” on page 42.

Origin200 Specifications

Table 5-1 lists the physical specifications of the Origin200 chassis.

Table 5-1 Origin200 Chassis Physical Specifications

Dimensions

With skins: (Vertical, tower config.)	length	26" (66 cm)
	width (without feet)	7.5" (19.1 cm)
	height	22.4" (56.9 cm)

Without skins: (Horizontal, rack config.)	length	24.3" (61.7 cm)
	width	18.9" (48 cm)
	height	6.8" (17.3 cm)

Shipping:	length	31.5" (80 cm)
	width	27.5" (69.9 cm)
	height	23" (58.4 cm)

Weight:	minimum	59 lbs (26.8 kg)
	maximum	67 lbs (30.4 kg)
	shipping (max.)	77 lbs (35 kg)
	drive modules (up to 8)	1 to 5 lbs (0.45 to 2.3 kg) each

Air Temperature

Operating:	0-5,000 ft	41° to 95° F (5° to 35° C)
	5,000-10,000 ft	41° to 86° F (5° to 30° C)

Non-Operating:	-4° to 140° F (-20° to 60° C)
-----------------------	-------------------------------

Thermal Gradient:	maximum	18° F (10° C) per hour
--------------------------	---------	------------------------

Table 5-1 (continued) Origin200 Chassis Physical Specifications

Altitude:	operating non-operating	10,000 ft (3,048 m) MSL, maximum 40,000 ft (12,192 m) MSL, maximum
Relative Humidity:	operating non-operating	10-90% (non-condensing) 10-95% (non-condensing)
Humidity Gradient:	maximum	10% relative humidity per hour
Acoustics:	typical	50 dBa
Vibration:	maximum, sustained maximum, peak sensitive frequency	0.01", 5-10 Hz; 0.1 G 10-500 Hz (operating) 0.02", 5-10 Hz; 0.1 G 10-500 Hz (operating) 8-33 Hz (varies with configuration)

Origin200 Power and Cooling Requirements

Table 5-2 provides power consumption and required cooling capacity information for the Origin200 system. For formulas, descriptions, and general information about power and cooling, refer to “Electrical Requirements” on page 13 and “Thermal Requirements” on page 17.

Caution: Origin200 systems are highly configurable, and different configurations can have a wide range of power and cooling requirements. It is uncommon for an Origin200 system to reach the “maximum” power and cooling requirements listed in Table 5-2. Ask your SGI representative about particular configurations.

Table 5-2 Origin200 Power and Cooling Specifications

Volts:		100-120 volts AC, 1-phase 200-240 volts AC, 1-phase
Watts (from-the-wall):	typical maximum	350 watts 600 watts (see “Caution,” above)
Power Factor:	minimum	0.98

Table 5-2 (continued) Origin200 Power and Cooling Specifications

Total Harmonic Dist.:	at 120 volts	5% maximum
Inrush Current:	peak	140 amps
Frequency:		47-63 Hz
Cooling Requirements: (Also see "Caution" on page 18)	typical maximum	1,194 Btu/hr (0.10-ton AC load) 2,046 Btu/hr (0.17-ton AC load) (see "Caution," above)
Airflow Volume:	maximum	100 cfm (0.047 m ³ /s)

See Appendix B, "Site Power and Power Cables," for information about Origin200 chassis site-wiring and power cables.

Origin200 External Peripherals

Origin200 systems usually use a standard serial ASCII terminal as a console. See "ASCII Terminals" on page 113 for more information.

An Origin200 system may also have one or more external SCSI devices attached to it. For small SCSI devices, see "External SCSI Devices" on page 112. Also see information on Origin Vault systems in "Origin Vault Site Requirements" on page 51.

Origin200 Cabling Issues

Besides power cables and external SCSI peripherals (mentioned above), Origin200 systems are typically wired to network cables, serial and parallel devices, and so on. For details of the ports found on an Origin200 system, see the *Origin200 Owner's Guide*.

An Origin200 system may also be connected to another Origin200 system with a CrayLink cable (as shown in Figure 5-4).



Warning: Any difference in ground potential greater than 500 millivolts (0.5 volts) between two chassis connected with CrayLink or XTown cables can cause severe equipment damage. For further information, see “Chassis Branch Circuit Grounding” on page 119.

Origin Vault Site Requirements

For information about selecting a physical location for an Origin Vault system, see “Selecting a Location for an Origin200 or Origin Vault System” on page 42.

Origin Vault Specifications

Table 5-3 lists the physical specifications of the Origin Vault chassis.

Table 5-3 Origin Vault Physical Specifications

Dimensions		
With skins:	length	26" (66 cm)
	width (without feet)	7.5" (19.1 cm)
	height	22.4" (56.9 cm)
Without skins:	length	24.3" (61.7 cm)
	width	18.9" (48 cm)
	height	6.8" (17.3 cm)
Shipping:	length	31.5" (80 cm)
	width	27.5" (69.9 cm)
	height	23" (58.4 cm)
Weight:	minimum	30 lbs (13.6 kg)
	maximum	55 lbs (25 kg)
	shipping (max.)	65 lbs (29.5 kg)
	drive modules (up to 8)	1 to 5 lbs (0.45 to 2.3 kg) each
Air Temperature		
Operating:	0-5,000 ft	41° to 95° F (5° to 35° C)
	5,000-10,000 ft	41° to 86° F (5° to 30° C)
Non-Operating:		-4° to 140° F (-20° to 60° C)
Thermal Gradient:	maximum	18° F (10° C) per hour

Table 5-3 (continued) Origin Vault Physical Specifications

Altitude:	operating non-operating	10,000 ft (3,048 m) MSL, maximum 40,000 ft (12,192 m) MSL, maximum
Relative Humidity:	operating non-operating	10-90% (non-condensing) 10-95% (non-condensing)
Humidity Gradient:	maximum	10% relative humidity per hour
Acoustics:	typical	50 dBa
Vibration:	maximum, sustained maximum, peak sensitive frequency	0.01", 5-10 Hz; 0.1 G 10-500 Hz (operating) 0.02", 5-10 Hz; 0.1 G 10-500 Hz (operating) 8-33 Hz (varies with configuration)

Origin Vault Power and Cooling Requirements

Table 5-4 provides power consumption and required cooling capacity information for the Origin Vault chassis. For formulas, descriptions, and general information about power and cooling, refer to “Electrical Requirements” on page 13 and “Thermal Requirements” on page 17.

Caution: The power and cooling requirements for an Origin Vault chassis vary significantly based on the quantity and type of peripheral devices installed in that chassis. It is rare for an Origin Vault chassis to reach the “maximum” power and cooling requirements listed in Table 5-4. Ask your SGI representative about particular configurations.

Table 5-4 Origin Vault Power and Cooling Specifications

Volts:		100-120 volts AC, 1-phase 200-240 volts AC, 1-phase
Watts (from-the-wall):	typical maximum	100 watts 200 watts (see “Caution,” above)

Table 5-4 (continued) Origin Vault Power and Cooling Specifications

Power Factor:	minimum	0.98
Total Harmonic Dist.:	at 120 volts	5% maximum
Inrush Current:	peak	140 amps
Frequency:		47-63 Hz
Cooling Requirements: (Also see "Caution" on page 18)	typical maximum	341 Btu/hr (0.03-ton AC load) 682 Btu/hr (0.06-ton AC load) (see "Caution," above)
Airflow Volume:	maximum	100 cfm (0.047 m ³ /s)

See Appendix B, "Site Power and Power Cables," for information about Origin200 chassis site-wiring and power cables.

Origin Vault SCSI-Cable Considerations

The Origin Vault chassis is available with either a single-ended or differential SCSI interface. Single-ended SCSI has a maximum bus-length of 3 meters. Differential SCSI has a maximum bus-length of 25 meters. These lengths, however, include all portions of the SCSI cable, both inside and outside the chassis. Where possible, it is best to keep SCSI buses well below these rated maximum lengths.

The cables will probably not run in a straight line from the host system's SCSI port to the Origin Vault chassis. Instead, they may run under a floor, or around systems. In this way, systems with a straight-line distance that is well within the limitations of the SCSI bus may, in fact, be too far apart.

Consider all of these factors when choosing a site for an Origin Vault chassis.

Site Preparation for SGI 2000-Series and Onyx2 Base Modules and Deskside Systems

The SGI 2000-series and Silicon Graphics Onyx2 family is made up entirely of base modules. These may be used alone (as SGI 2100, SGI 2200, or Silicon Graphics Onyx2 deskside systems) or in various combinations (as SGI 2400, SGI 2800, or Silicon Graphics Onyx2 rack systems).

This chapter details the base modules. Considerations involving multiple base modules assembled into racks are addressed in Chapter 8, “Site Preparation for SGI 2000-series, Origin Peripherals, and Onyx2 Rack Chassis.”

A brief overview of these systems follows. While these descriptions are current as of the date of publication, please refer to the most recent price book for the latest information.

- SGI 2100, SGI 2200—Compute-oriented multiprocessor systems containing between one and eight MIPS CPUs (previously called “Origin2000 deskside”).
- Onyx2—High-performance graphics workstations containing between one and four MIPS CPUs.

Note: In this guide, the term “SGI 2000-series” is used to refer to SGI Origin2000, SGI 2100, SGI 2200, SGI 2400, and SGI 2800 server systems.

SGI 2000-Series Deskside and Onyx2 Deskside Shipping Crate

Figure 6-1 illustrates and lists the dimensions of the shipping crate used for the SGI 2000-series deskside and Silicon Graphics Onyx2 deskside chassis.

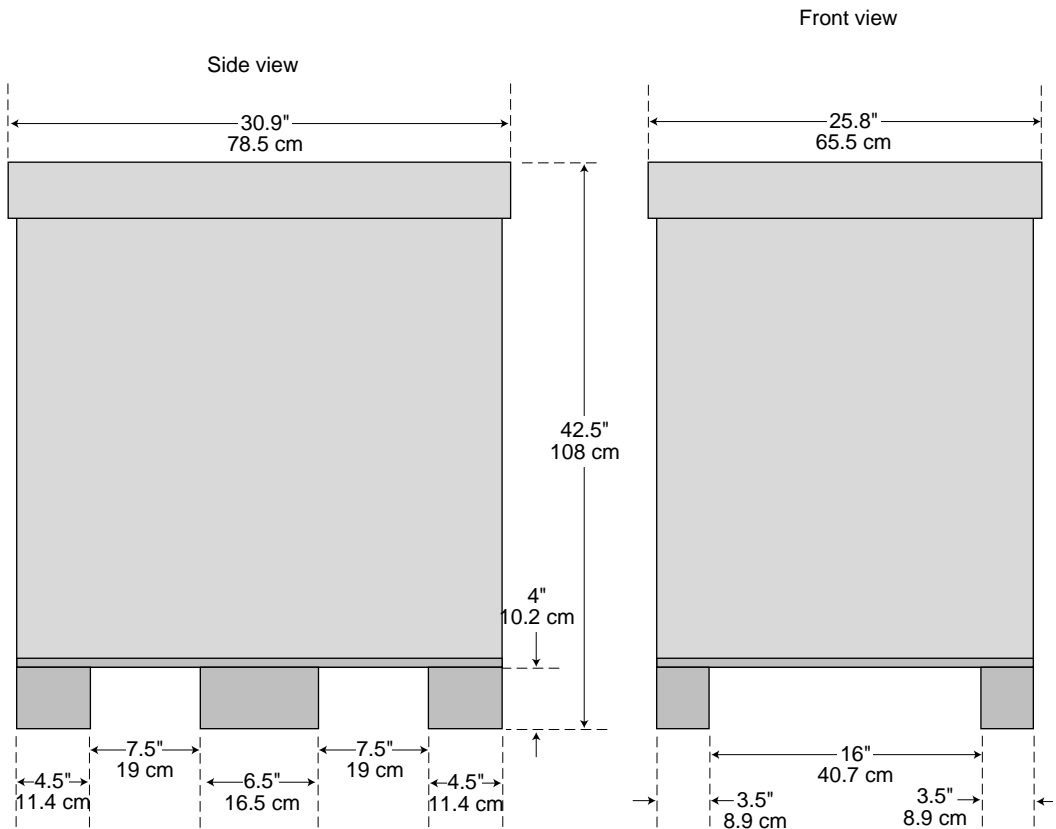

Figure 6-1 SGI 2000-Series Deskside and Onyx2 Deskside Shipping Crate

Selecting a Location for an SGI 2000-Series Deskside or Onyx2 Deskside System

Figure 6-2 shows a typical SGI 2000-series deskside system installation, along with an optional terminal. The Silicon Graphics Onyx2 deskside system looks similar, but is typically connected to a large monitor, keyboard, and mouse (rather than a terminal).

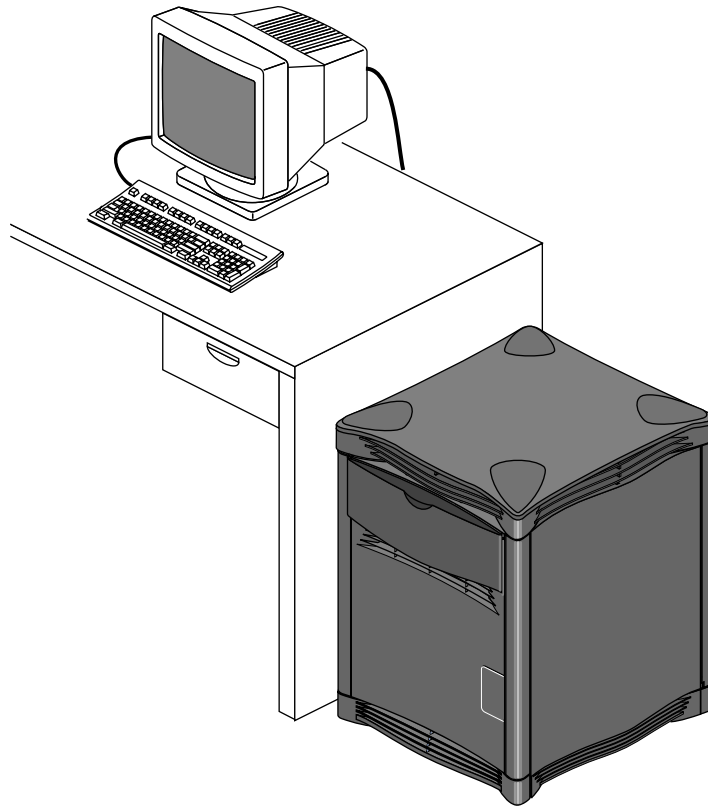

Figure 6-2 SGI 2000-Series Deskside Typical Installation, With Terminal (Onyx2 Similar)

Airflow Clearance for SGI 2000-Series Deskside and Onyx2 Deskside Systems

Table 6-1 lists the minimum clearances for airflow to the SGI 2000-series deskside and Silicon Graphics Onyx2 deskside chassis. The clearances are listed in two groups: The first group applies if the chassis has 6" or less of unobstructed air space above it. The second group applies if the chassis has more than 6" of unobstructed air space above it.

Table 6-1 SGI 2000-Series Deskside and Onyx2 Deskside Minimum Airflow Clearances

Top Clearance	Left Side	Right Side	Front	Back
6" (15 cm) or less	6" (15 cm)	6" (15 cm)	8" (20 cm)	8" (20 cm)
More than 6" (15 cm)	1" (2.5 cm)	1" (2.5 cm)	8" (20 cm)	8" (20 cm)

Service Clearance for SGI 2000-Series and Onyx2 Deskside Systems

Service clearances are typically not an issue for the deskside chassis, since the chassis is on casters and is light enough to be moved for service. For permanent installations, or in locations where service clearance is an issue, Table 6-2 lists suggested minimum service clearances.

Table 6-2 SGI 2000-Series Deskside and Onyx2 Deskside Recommended Minimum Service Clearances

Top	Left Side	Right Side	Front	Back
-	-	-	30" (76 cm)	30" (76 cm)

Caution: Do not place more than 25 lbs (11.5 kg) on top of an SGI 2000-series deskside or Silicon Graphics Onyx2 deskside chassis. Though there is no airflow through the top, it is not designed to support heavy loads.

Airflow in SGI 2000-Series Deskside and Onyx2 Deskside Systems

Position the chassis so that it receives proper air circulation. Figure 6-3 illustrates the airflow path through the SGI 2000-series deskside and Silicon Graphics Onyx2 deskside chassis. It is important that nothing block the areas shown by arrows.

SGI 2000-series deskside and Silicon Graphics Onyx2 deskside systems are designed for use in typical office computing environments: The air temperature should not fluctuate dramatically, air should circulate freely, and the location should be relatively dust-free.

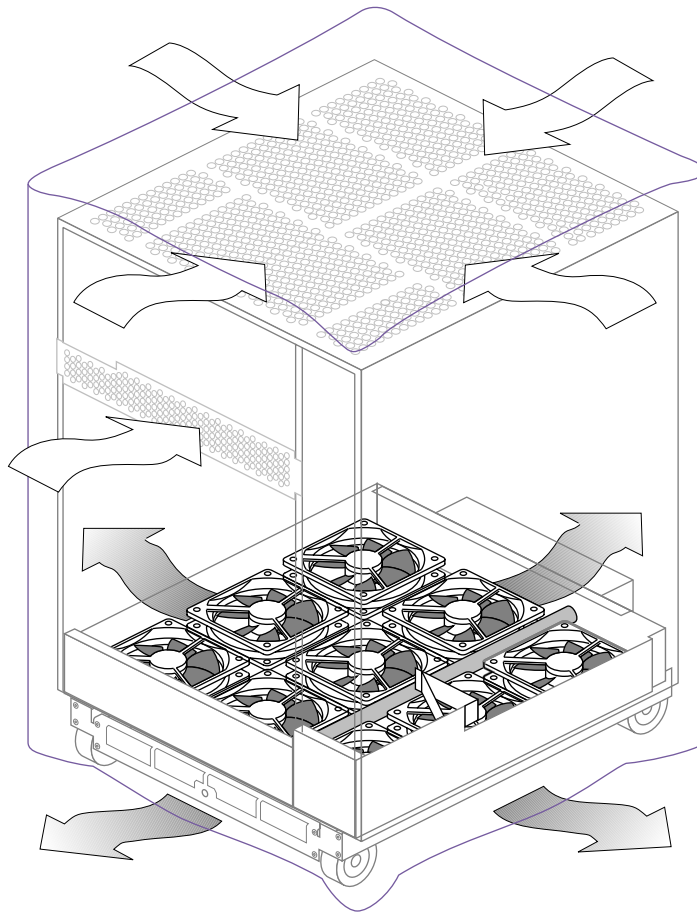

Figure 6-3 SGI 2000-Series Deskside and Onyx2 Deskside Airflow

Casters on SGI 2000-Series Deskside and Onyx2 Deskside Systems

Figure 6-4 shows the approximate caster positions for the SGI 2000-series deskside and Silicon Graphics Onyx2 deskside systems. Ensure that these do not present a problem at the intended site.

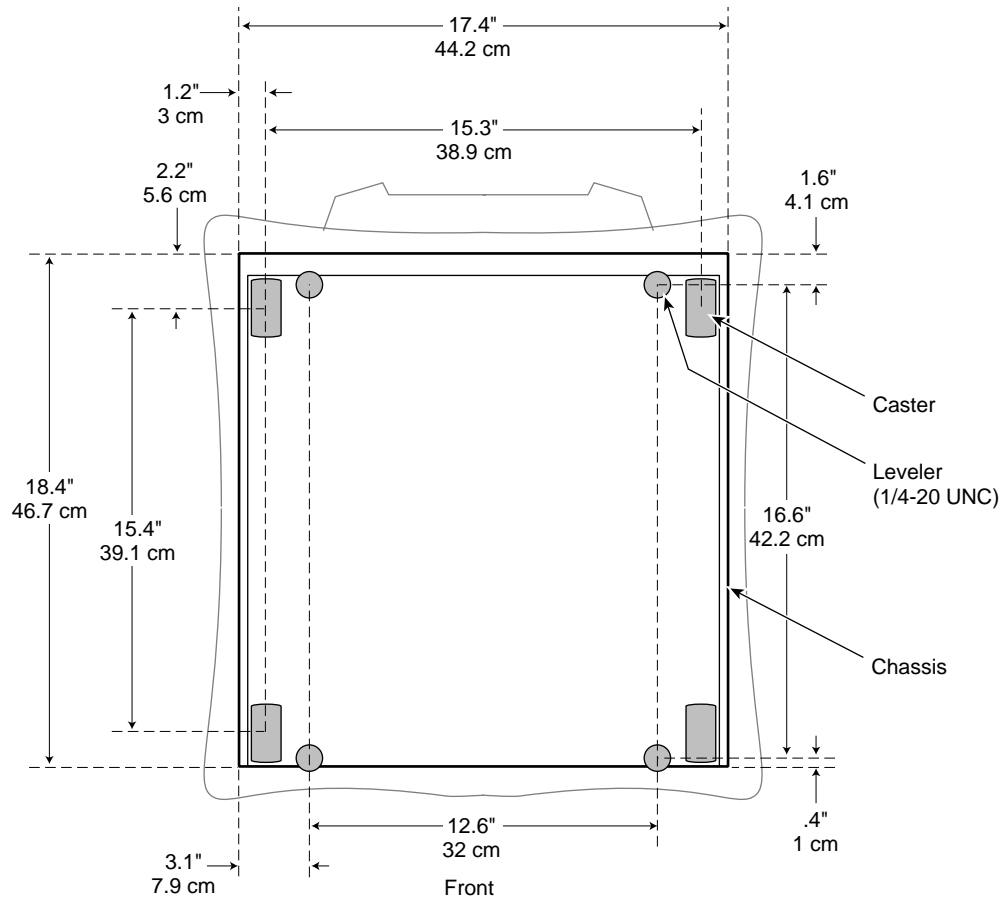

Figure 6-4 SGI 2000-Series Deskside and Onyx2 Deskside Caster Positions

SGI 2000-Series Base Module Site Requirements

For information about selecting a location for an SGI 2000-series deskside system, see “Selecting a Location for an SGI 2000-Series Deskside or Onyx2 Deskside System” on page 57.

Note: All references in this section to “base modules” also apply to deskside systems, unless otherwise specified

Note: All references in this section to SGI 2000-series systems also apply to Origin2000 systems.

SGI 2000-Series Base Module Specifications

Table 6-3 lists the physical specifications of the SGI 2000-series base modules.

Table 6-3 SGI 2000-Series Base Module Physical Specifications

Dimensions

With skins:	length	24" (61 cm)
	width	19.8" (50.3 cm)
	height	26.5" (67.3 cm)
Without skins:	length	21" (53.3 cm)
	width	17.7" (45 cm)
	height	23.9" (60.7 cm)
Shipping:	length	30.9" (78.5 cm)
	width	25.8" (65.5 cm)
	height	42.5" (108 cm)

Weight:	minimum	120 lbs (54.4 kg)
	maximum	170 lbs (77 kg)
	shipping (max.)	190 lbs (86.2 kg)

Floor Loading (average):	minimum	36 lb/ft ² (175 kg/m ²)
	maximum	51 lb/ft ² (250 kg/m ²)

Air Temperature

Table 6-3 (continued) SGI 2000-Series Base Module Physical Specifications

Operating:	0-5,000 ft	41° to 95° F (5° to 35° C)
	5,000-10,000 ft	41° to 86° F (5° to 30° C)
Non-Operating:		-4° to 140° F (-20° to 60° C)
Thermal Gradient:	maximum	18° F (10° C) per hour
Altitude:	operating	10,000 ft (3,048 m) MSL, maximum
	non-operating	40,000 ft (12,192 m) MSL, maximum
Relative Humidity:	operating	10-90% (non-condensing)
	non-operating	10-95% (non-condensing)
Humidity Gradient:	maximum	10% relative humidity per hour
Acoustics:	typical	50 dBa
Vibration:	maximum, sustained	0.01", 5-10 Hz; 0.1 G 10-500 Hz (operating)
	maximum, peak	0.02", 5-10 Hz; 0.1 G 10-500 Hz (operating)
	sensitive frequency	8-33 Hz (varies with configuration)

SGI 2000-Series Base Module Power and Cooling Requirements

SGI 2000-series base modules are designed to run on 120 volts or 208 volts (see "Voltage Requirements" on page 13). Although the power supply automatically switches voltages, certain configurations do not work when the system is connected to a 120-volt power source. Table 6-4 lists the minimum voltage requirements for various SGI 2000-series deskside configurations.

Modules contained in racks (i.e., in SGI 2400, SGI 2800, and Origin2000 rack systems) are designed to run only on 208-volt power.

It is much easier to install ample power during initial site preparation than it is to upgrade power later when wiring is in place and a site is in operation. For this reason, if the system might require 208 volts in the future, it is a good idea to install it now.

Table 6-4 Minimum Voltage Requirements for SGI 2000-Series Deskside Systems

System Type	Configuration	Minimum Nominal Voltage
SGI 2000-Series Deskside:	1 or 2 node boards	120 volts
	3 or 4 node boards	208 volts

Note: SGI 2000-series deskside systems, regardless of configuration, are not designed to run on Japanese 100-volt power. This is because the 120-volt configurations listed in Table 6-4 require a minimum of 100 volts, and Japanese 100-volt power, while nominally 100 volts, may drop to as low as 90 volts. All SGI 2000-series systems in Japan should thus be supplied with 200-volt power. All SGI 2000-series configurations are designed to function properly on Japanese 200-volt power.

Table 6-5 provides power consumption and required cooling capacity information for SGI 2000-series base modules. For formulas, descriptions, and general information about power and cooling, refer to “Electrical Requirements” on page 13 and “Thermal Requirements” on page 17.

Caution: SGI 2000-series base modules are highly configurable, and different configurations can have a wide range of power and cooling requirements. It is very rare for an SGI 2000-series base module to reach the “maximum” power and cooling requirements listed in Table 6-5. Ask your SGI representative about particular configurations.

Table 6-5 SGI 2000-Series Base Module Power and Cooling Specifications

Volts:		100-120 volts AC, 1-phase 200-240 volts AC, 1-phase
Watts (from-the-wall):	typical maximum	850 watts 1,850 watts (see “Caution,” above)
Power Factor:	minimum	0.98

Table 6-5 (continued) SGI 2000-Series Base Module Power and Cooling Specifications

Total Harmonic Dist.:	maximum at 120 volts	5%
Inrush Current:	peak	140 amps
Frequency:		47-63 Hertz
Cooling Requirements: (Also see "Caution" on page 18)	typical maximum	2,899 Btu/hr (0.24-ton AC load) 6,309 Btu/hr (0.53-ton AC load (see "Caution," above))
Airflow Volume:	maximum	350 cfm (0.1645 m ³ /s)

See Appendix B, "Site Power and Power Cables," for information about SGI 2000-series base module site-wiring and power cables.

SGI 2000-Series Base Module External Peripherals

SGI 2000-series base modules usually use a standard serial ASCII terminal as a console. See "ASCII Terminals" on page 113 for more information.

An SGI 2000-series base module may also have one or more external SCSI devices attached to it. For small SCSI devices, see "External SCSI Devices" on page 112. Also see information about Origin Vault systems in "Origin Vault Site Requirements" on page 51.

SGI 2000-Series Base Module Cabling Issues

Besides connecting to power cables and external SCSI peripherals, SGI 2000-series base modules are typically wired to network cables, serial devices, and so on. For details of the ports found on an SGI 2000-series base module, see the *SGI 2100 Owner's Guide*.

Onyx2 Deskside System Site Requirements

There are two variations of the Silicon Graphics Onyx2 graphics subsystem: Onyx2 Reality and Onyx2 InfiniteReality. Places where these differ from a site-preparation standpoint are pointed out in the text.

For information about selecting a physical location for a Silicon Graphics Onyx2 deskside system, see "Selecting a Location for an SGI 2000-Series Deskside or Onyx2 Deskside System" on page 57.

Onyx2 Deskside System Specifications

Table 6-6 lists the physical specifications of the Silicon Graphics Onyx2 deskside system.

Table 6-6 Onyx2 Deskside System Physical Specifications

Dimensions		
With skins:	length	24" (61 cm)
	width	19.8" (50.3 cm)
	height	26.5" (67.3 cm)
Without skins:	length	21" (53.3 cm)
	width	17.7" (45 cm)
	height	23.9" (60.7 cm)
Shipping:	length	30.9" (78.5 cm)
	width	25.8" (65.5 cm)
	height	42.5" (108 cm)
Weight:	minimum	120 lbs (54.4 kg)
	maximum	170 lbs (77 kg)
	shipping (max.)	190 lbs (86.2 kg)
Floor Loading:	minimum	36 lb/ft ² (175 kg/m ²)
	maximum	51 lb/ft ² (250 kg/m ²)
Air Temperature		
Operating:	0-5,000 ft	41° to 95° F (5° to 35° C)
	5,000-10,000 ft	41° to 86° F (5° to 30° C)

Table 6-6 (continued) Onyx2 Deskside System Physical Specifications

Non-Operating:		-4° to 140° F (-20° to 60° C)
Thermal Gradient:	maximum	18° F (10° C) per hour
Altitude:	operating non-operating	10,000 ft (3,048 m) MSL, maximum 40,000 ft (12,192 m) MSL, maximum
Relative Humidity:	operating non-operating	10-90% (non-condensing) 10-95% (non-condensing)
Humidity Gradient:	maximum	10% relative humidity per hour
Acoustics:	typical	50 dBa
Vibration:	maximum, sustained maximum, peak sensitive frequency	0.01", 5-10 Hz; 0.1 G 10-500 Hz (operating) 0.02", 5-10 Hz; 0.1 G 10-500 Hz (operating) 8-33 Hz (varies with configuration)

Onyx2 Deskside System Power and Cooling Requirements

Silicon Graphics Onyx2 deskside systems are designed to run on 120 volts or 208 volts (see "Voltage Requirements" on page 13). Although the power supply automatically switches voltages, certain configurations do not work when the system is connected to a 120-VAC power source. Table 6-7 lists the minimum voltage requirements for various Silicon Graphics Onyx2 deskside system types and configurations.

It is much easier to install ample power during initial site preparation than it is to upgrade power later when wiring is in place and a site is in operation. For this reason, if the system might require 208 volts in the future, it is a good idea to install it now.

Table 6-7 Minimum Voltage Requirements for Onyx2 Deskside Systems

System Type	Configuration	Minimum Nominal Voltage
Onyx2 Reality	1 node board, 1 RM8	120 volts
	1 node board, 2 RM8s	120 volts
	2 node boards, 1 RM8	120 volts
	2 node boards, 2 RM8s	208 volts
Onyx2 InfiniteReality or Onyx2 InfiniteReality2	1 node board, 1 RM7 or RM9	120 volts
	1 node board, 2 RM7s or RM9s	208 volts
	2 node boards, 1 RM7 or RM9	208 volts
	2 node boards, 2 RM7s or RM9s	208 volts

Note: Silicon Graphics Onyx2 deskside systems, regardless of configuration, are not designed to run on Japanese 100-volt power. This is because the 120-volt configurations listed in Table 6-7 require a minimum of 100 volts, and Japanese 100-volt power, while nominally 100 volts, may drop to as low as 90 volts. All Silicon Graphics Onyx2 deskside systems in Japan must therefore be supplied with 200-volt power. All Silicon Graphics Onyx2 deskside configurations are designed to function properly on Japanese 200-volt power.

Table 6-8 provides power consumption and required cooling capacity information for Silicon Graphics Onyx2 deskside systems. For formulas, descriptions, and general information about power and cooling, refer to “Electrical Requirements” on page 13 and “Thermal Requirements” on page 17.

Caution: Silicon Graphics Onyx2 deskside systems are highly configurable, and different configurations can have a wide range of power and cooling requirements. It is very rare for a Silicon Graphics Onyx2 deskside system to reach the “maximum” power and cooling requirements listed in Table 6-8. Ask your SGI representative about particular configurations.

Table 6-8 Onyx2 Deskside System Power and Cooling Specifications

Volts:		100-120 volts AC, 1-phase 200-240 volts AC, 1-phase
Watts (from the wall):	typical maximum	850 watts 2,000 watts (see “Caution,” above)
Power Factor:	minimum	0.98
Total Harmonic Dist.:	at 120 volts	5% maximum
Inrush Current:	peak	140 amps
Frequency:		47-63 Hertz
Cooling Requirements: (Also see “Caution” on page 18)	typical maximum	2,899 Btu/hr (0.24-ton AC load) 6,820 Btu/hr (0.57-ton AC load (see “Caution,” above)
Airflow Volume:	maximum	350 cfm (0.1645 m ³ /s)

See Appendix B, “Site Power and Power Cables,” for information about Silicon Graphics Onyx2 deskside system site-wiring and power cables.

Onyx2 Deskside System External Peripherals

A Silicon Graphics Onyx2 deskside system typically has one or more monitors, keyboards, and mice. See “Monitors” on page 109, “Keyboards” on page 112, and “Mice” on page 112 for more information.

A Silicon Graphics Onyx2 deskside system may also have one or more external SCSI devices attached to it. For small SCSI devices, see “External SCSI Devices” on page 112. Also see information about Origin Vault systems in “Origin Vault Site Requirements” on page 51.

Onyx2 Deskside System Cabling Issues

Besides connecting to power cables and external SCSI peripherals, Silicon Graphics Onyx2 deskside systems are typically wired to network cables, serial and parallel devices, and so on. For details of the ports found on a Silicon Graphics Onyx2 deskside systems, see the *Onyx2 Deskside Workstation Owner's Guide*.

Site Preparation for Onyx2 Graphics Insert Modules

The Onyx2 product line includes a rack version. The rack systems use one or more SGI 2000-series base modules (see “SGI 2000-Series Base Module Site Requirements” on page 61) and one or more Onyx2 graphics insert modules (described in this chapter).

The Onyx2 graphics insert module (GIM), unlike the SGI 2000-series modules, may be used *only* in a rack chassis.

Selecting a Location for an Onyx2 Graphics Insert Module

The Onyx2 graphics insert module is always mounted in a rack alone, with another Onyx2 graphics insert module, or with an SGI 2000-series base module.

Figure 7-1 shows a rear view of an Onyx2 graphics insert module.

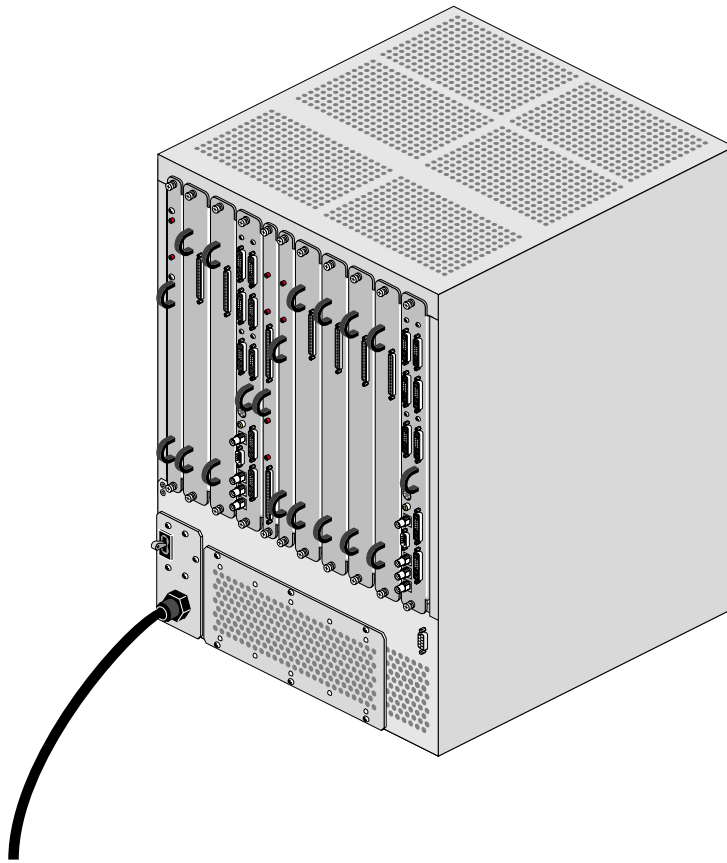

Figure 7-1 Onyx2 Graphics Insert Module, Rear View

Airflow in Onyx2 Graphics Insert Modules

Position the Onyx2 graphics insert module so that it receives proper air circulation. The airflow is in at the top of the chassis and out the fan at the bottom rear of the chassis, as shown in Figure 7-2. It is important that nothing block the areas shown by arrows. Onyx2 graphics insert modules are always installed in rack chassis. To see the airflow in an Onyx2 rack chassis, refer to Figure 8-6.

Onyx2 graphics insert modules are designed for use in typical office computing environments: The air temperature should not fluctuate dramatically, air should circulate freely, and the location should be relatively dust free.

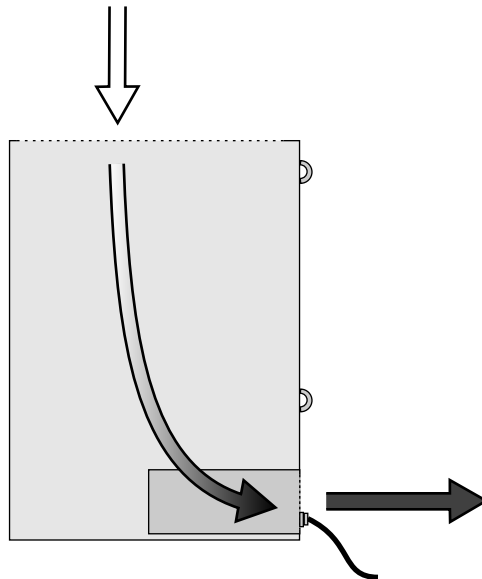

Figure 7-2 Onyx2 Graphics Insert Module Airflow

Onyx2 Graphics Insert Module Site Requirements

The Onyx2 graphics insert module is an insert chassis that is used only in rack systems. An Onyx2 graphics insert module may share a rack with another Onyx2 graphics insert module or with an SGI 2000-series base module, or may be alone in a rack.

For information about selecting a physical location for a rack system containing an Onyx2 graphics insert module, see “Selecting a Location for an SGI 2000-Series, Origin Peripherals, or Onyx2 Rack System” on page 81.

Onyx2 Graphics Insert Module Specifications

Table 7-1 lists the physical specifications of the Onyx2 graphics insert module.

Table 7-1 Onyx2 Graphics Insert Module Physical Specifications

Dimensions		
Installed:	length	19.9" (50.5 cm)
	width	17.4" (44.2 cm)
	height	26" (66 cm)
Shipping:	length	30.9" (80 cm)
	width	25.8" (61 cm)
	height	42.5" (104.1 cm)
Weight:	minimum	125 lbs (56.7 kg)
	maximum	175 lbs (79.4 kg)
	shipping (max.)	195 lbs (88.5 kg)
Air Temperature		
Operating:	0-5,000 ft	41° to 95° F (5° to 35° C)
	5,000-10,000 ft	41° to 86° F (5° to 30° C)
Non-Operating:		-4° to 140° F (-20° to 60° C)
Thermal Gradient:	maximum	18° F (10° C) per hour

Table 7-1 (continued) Onyx2 Graphics Insert Module Physical Specifications

Altitude:	operating	10,000 ft (3,048 m) MSL, maximum
	non-operating	40,000 ft (12,192 m) MSL, maximum
Relative Humidity:	operating	10-90% (non-condensing)
	non-operating	10-95% (non-condensing)
Humidity Gradient:	maximum	10% relative humidity per hour
Acoustics:	typical	65 dBa

Onyx2 Graphics Insert Module Power and Cooling Requirements

Onyx2 graphics insert modules require 208 volt power (see “Voltage Requirements” on page 13) and have a fixed power cable that plugs directly into wall power, rather than plugging into the rack PDU. This is different from Onyx2 and Origin2000 modules, which plug into the rack PDU.



Warning: Any difference in ground potential greater than 500 millivolts (0.5 volts) between two chassis connected with CrayLink or XTown cables can cause a range of problems, from poor system operation to severe equipment damage. See “Chassis Branch Circuit Grounding” on page 119 for further information.

Table 7-2 provides power consumption and required cooling capacity information for the Onyx2 graphics insert modules. For formulas, descriptions, and general information about power and cooling, refer to “Electrical Requirements” on page 13 and “Thermal Requirements” on page 17.

Caution: Onyx2 systems are highly configurable, and therefore have a wide range of power and cooling requirements. It is very rare for an Onyx2 graphics insert module to reach the “maximum” power and cooling requirements listed in Table 7-2. Ask your SGI representative about particular configurations.

Table 7-2 Onyx2 Graphics Insert Module Power and Cooling Specifications

Volts:		200-240 volts AC, 1-phase
Watts (from the wall):	typical maximum	1,200 watts 2,000 watts (see “Caution,” above)
Power Factor:	minimum	0.98
Total Harmonic Dist.:	maximum	5%
Inrush Current:	peak	80 amps
Frequency:		47-53 Hertz 57-63 Hertz
Cooling Requirements: (Also see “Caution” on page 18)	typical maximum	4,092 Btu/hr (0.34-ton AC load) 6,820 Btu/hr (0.57-ton AC load) (see “Caution,” above)
Airflow Volume:	maximum	400 cfm (0.188 m ³ /s)

See Appendix B, “Site Power and Power Cables,” for information about graphics insert module site-wiring and power cables.

Onyx2 Graphics Insert Module External Peripherals

Onyx2 graphics insert modules are typically connected to one or more monitors. See “Monitors” on page 109 for more information.

Onyx2 Graphics Insert Module Cabling Issues

Besides power cables, Onyx2 graphics insert modules have one or two XTown cables connecting them to one or two SGI 2000-series base modules, either in the same rack or in one or two nearby racks.

Site Preparation for SGI 2000-series, Origin Peripherals, and Onyx2 Rack Chassis

The SGI 2000-series and Onyx2 rack chassis is formed of one or more basic units mounted in a custom rack. The SGI 2000-series base module is detailed in Chapter 6, and the Onyx2 graphics insert module (GIM) is detailed in Chapter 7.

These basic units may be placed into special SGI 2000-series or Onyx2 racks. Each rack may contain zero, one, or two of the above basic units, and a number of optional expansion modules, such as Origin Vault.

These racks, in turn, may be joined to form multi-rack systems. These systems are highly integrated, and, in effect, form one large computer system.

Many of these combinations use CrayLink, a custom, high-performance interconnection fabric designed specifically for this purpose.

In addition, Origin200 servers and Origin Vault peripheral chassis may be mounted in a very similar custom rack, called the Origin Peripherals Rack. The custom rack is detailed in this chapter, and the individual Origin200 and Origin Vault chassis are detailed in Chapter 5.

Note: In this guide, the term “SGI 2000-series” is used to refer to SGI Origin2000, SGI 2100, SGI 2200, SGI 2400, and SGI 2800 server systems.

SGI 2000-Series, Origin Peripherals, and Onyx2 Rack System Shipping Crate

Figure 8-1 illustrates and lists the dimensions of the shipping crate used for the SGI 2000-series, Origin Peripherals, and Onyx2 racks.

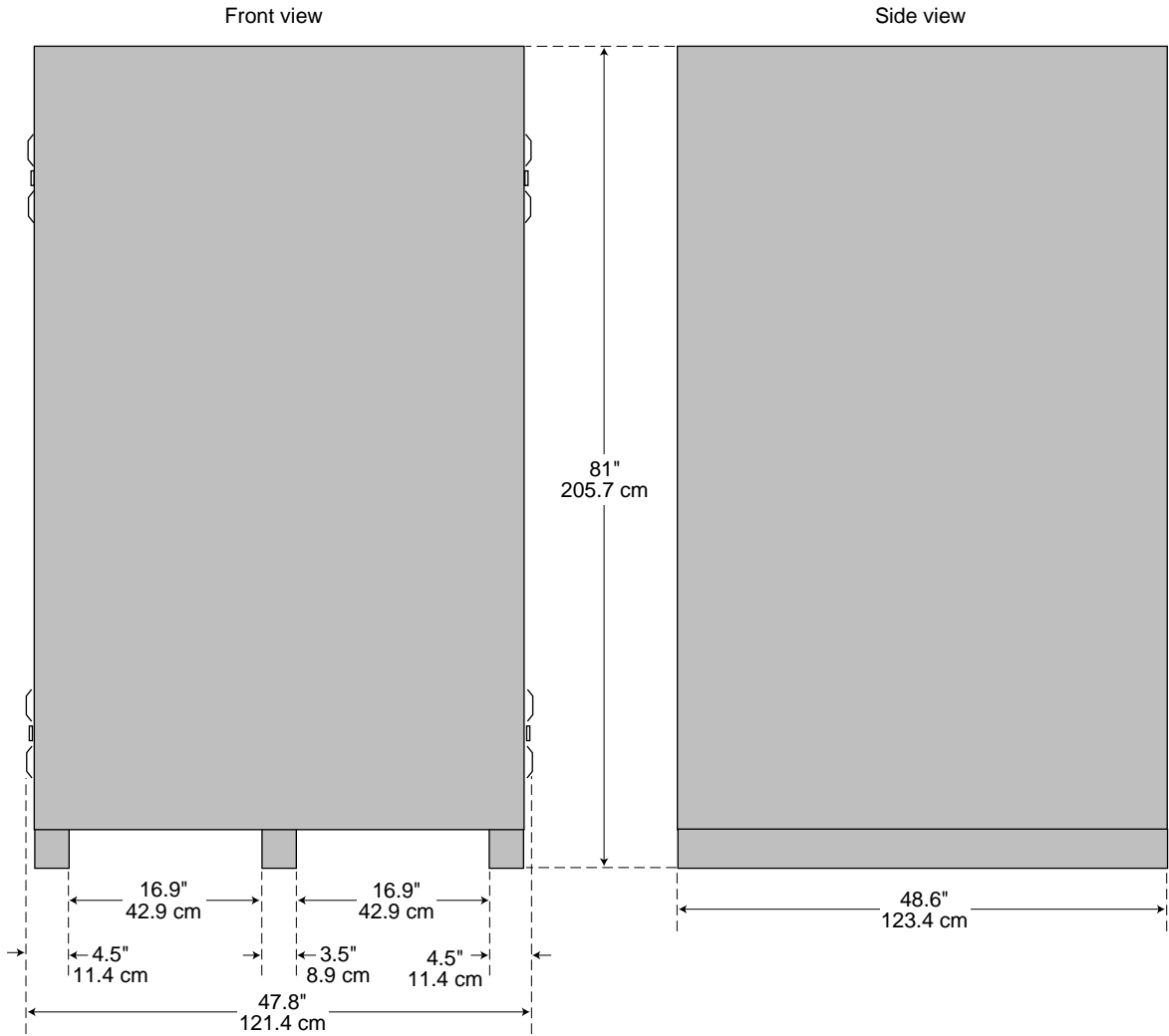

Figure 8-1 SGI 2000-Series, Origin Peripherals, and Onyx2 Rack Chassis Shipping Crate

Selecting a Location for an SGI 2000-Series, Origin Peripherals, or Onyx2 Rack System

SGI 2000-Series, Origin Peripherals, and Onyx2 rack systems are large, heavy units. Serious consideration must be given to choosing an appropriate location. Figure 8-2 shows an SGI 2000-series rack system (the doorway is shown for scale).

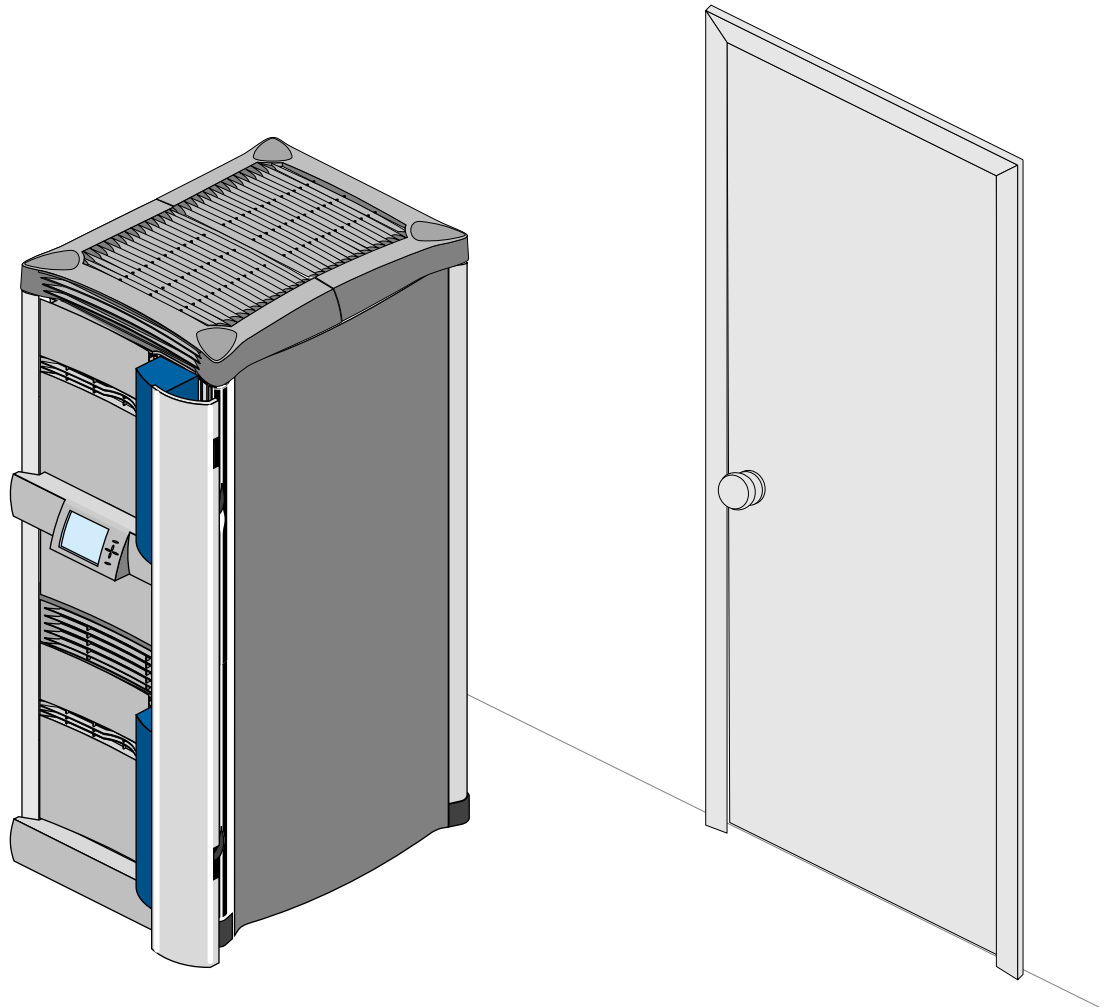

Figure 8-2 SGI 2000-Series Rack System (Origin Peripherals and Onyx2 Racks Similar, Not Shown)

Selecting a Location for a Single SGI 2000-Series, Origin Peripherals, or Onyx2 Rack System

This section details the things which must be considered when selecting a location for an SGI 2000-Series, Origin Peripherals, or Onyx2 rack system.

Clearances for SGI 2000-Series, Origin Peripherals, or Onyx2 Rack Systems

An SGI 2000-Series, Origin Peripherals or Onyx2 rack system requires enough space for the front doors to open, for the cable cover to swing to the side of the chassis, and for base modules to be lifted into place and mounted in the rack. It is also important that there be room to access the rear of the system, since most of the cables are routed to the back of the chassis. See Figure 8-3 for details.

In order to install and remove base modules, attach cables, and so on, there should be at least three feet of space at the front and rear of the system, or it should be possible to move the system to make space.

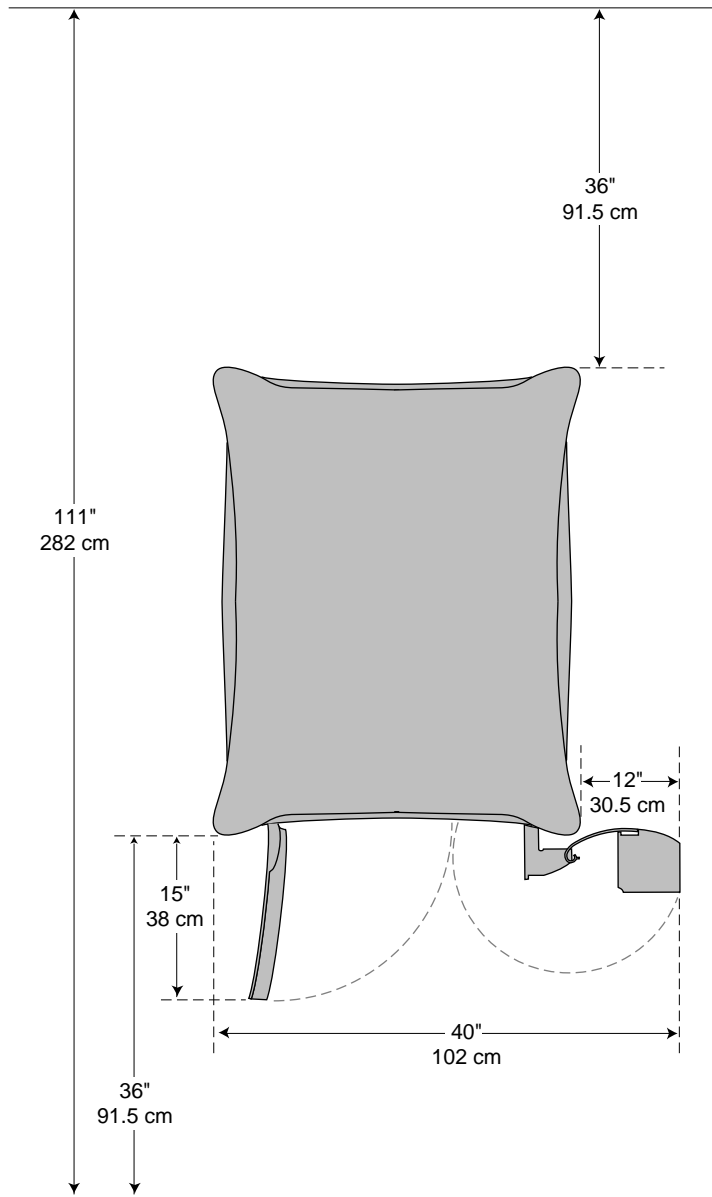

Figure 8-3 SGI 2000-Series, Origin Peripherals, and Onyx2 Rack Chassis Recommended Clearances

Floor Loading for SGI 2000-Series, Origin Peripherals, and Onyx2 Rack Systems

Ensure that the floor-load rating of the intended site meets the requirements for the system in question. Floor loadings for SGI 2000-Series, Origin Peripherals, and Onyx2 rack systems are listed in Table 8-1 (on page 97), Table 8-3 (on page 101), and Table 8-5 (on page 105).

Note: SGI 2000-series, Origin Peripherals, and Onyx2 rack systems are very heavy, and some sites do not have a floor-load rating capable of handling them.

For installations on raised floors, check that the construction can properly support the distribution of the weight. SGI 2000-series, Origin Peripherals, and Onyx2 rack systems use four casters or four stabilizing levelers that distribute the weight load to the site floor. See Figure 8-4 for the caster and leveler locations. If a floor has been modified, such as by cutting new access panels in computer-floor tiles, determine if additional reinforcement is required.

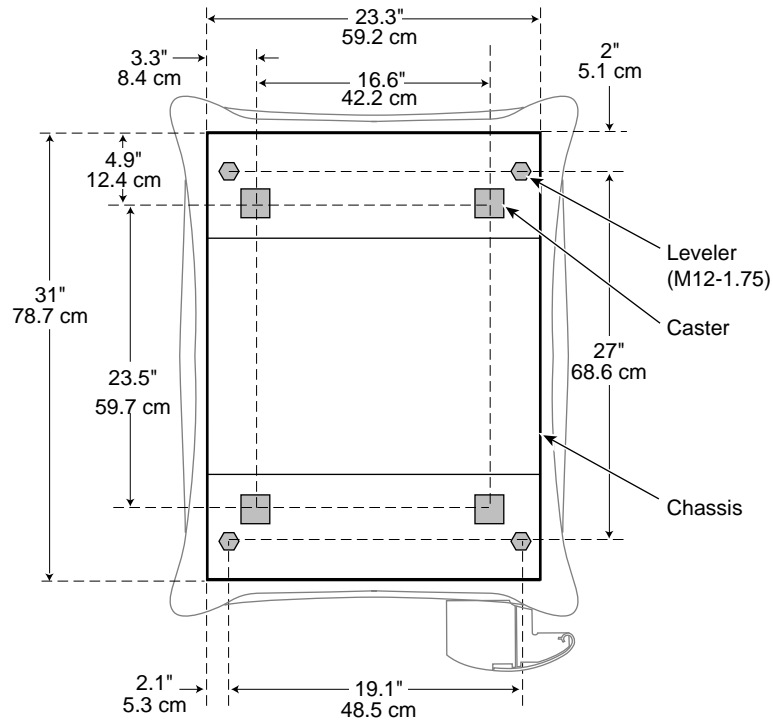

Figure 8-4 SGI 2000-Series Origin2000, Origin Peripherals, and Onyx2 Rack Chassis Caster and Leveler Locations

Airflow for SGI 2000-Series, Origin Peripherals, and Onyx2 Rack Systems

Position the chassis so that it receives proper air circulation. The airflow in the rack systems is in from the front and top, and out the back, as shown in Figure 8-5 (SGI 2000-series rack), Figure 8-6 (Onyx2 rack), and Figure 8-7 (Origin Peripherals rack). An ideal location provides cool air near the chassis air-intake vents and removes warm air from the area of the chassis air outlets.

SGI 2000-series, Origin Peripherals, and Onyx2 systems are designed for use in typical office computing environments: the air temperature should not fluctuate dramatically, air should circulate freely, and the location should be relatively dust free.

In installations with raised floors, it is a good idea to install perforated tiles for additional airflow to the systems. The additional airflow helps to keep systems cool, especially in crowded machine rooms. While perforated tiles are not strictly necessary, cooler equipment is more reliable. The ideal arrangement is to have one perforated tile in front of each rack system, as illustrated in Figure 8-8.

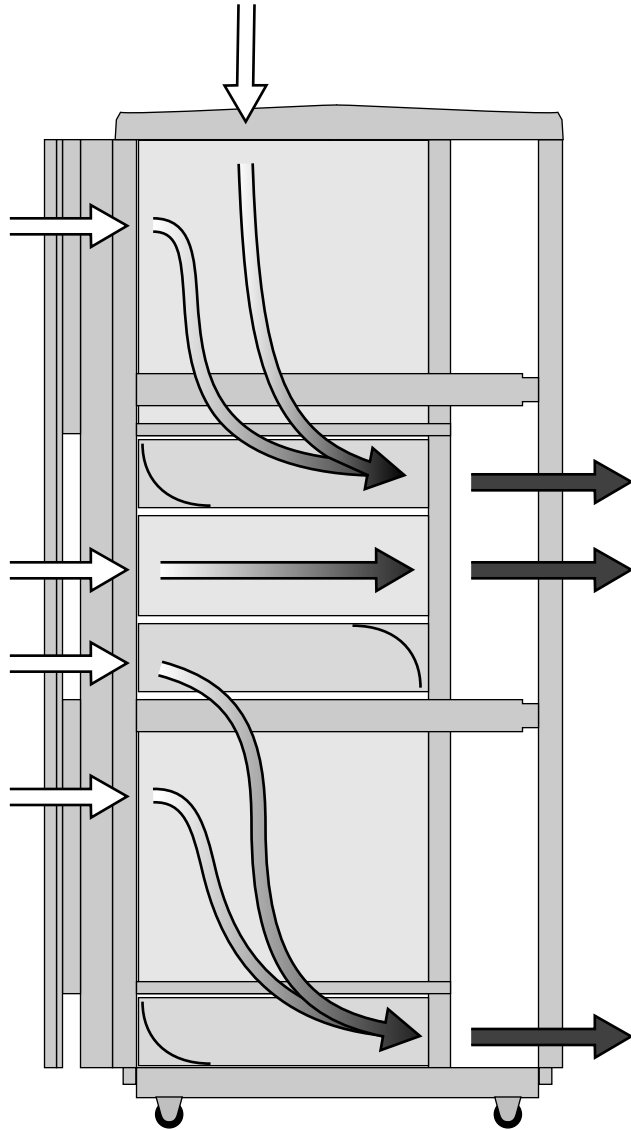

Figure 8-5 SGI 2000-Series Rack-Chassis Airflow (Shown With Two Base Modules and One Origin Vault)

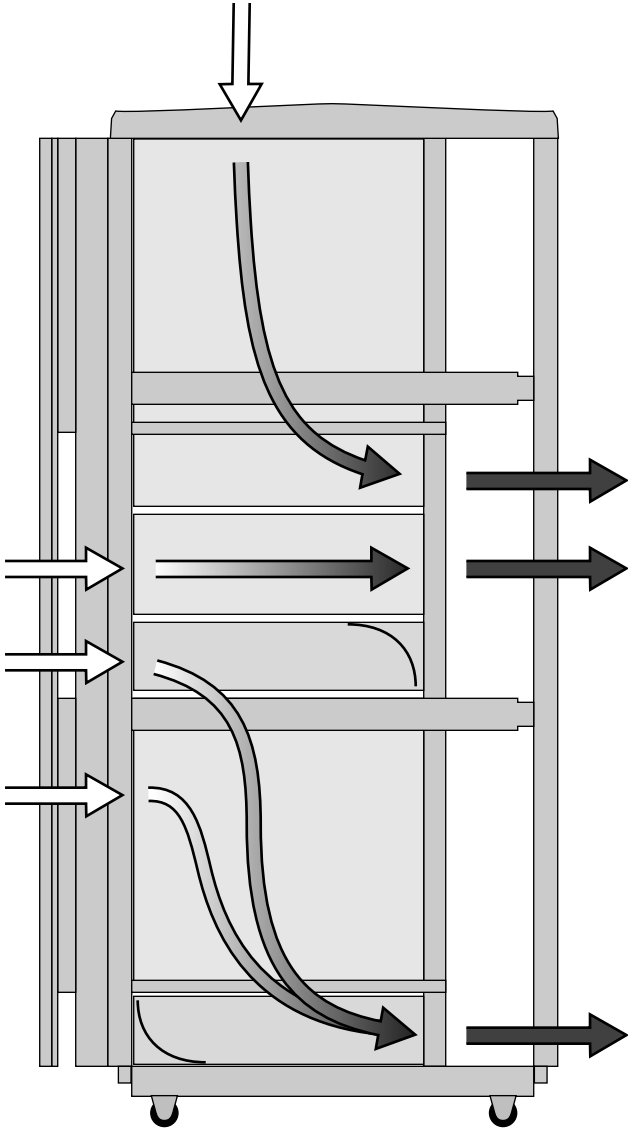

Figure 8-6 Onyx2 Rack-Chassis Airflow (Shown With One Base Module, One Onyx2 Graphics Insert Module, and One Origin Vault)

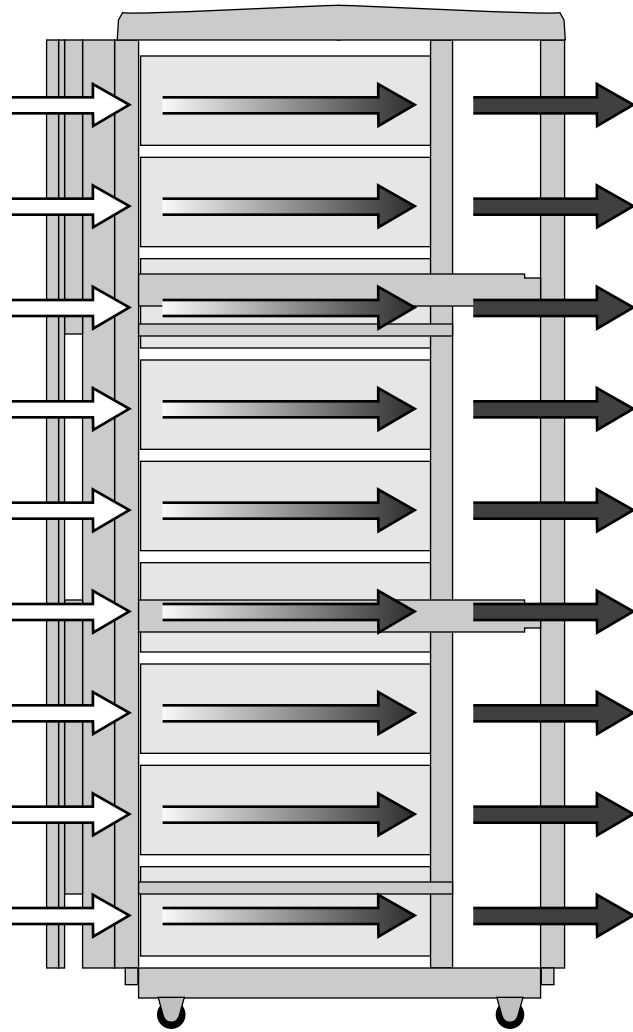

Figure 8-7 Origin Peripherals Rack-Chassis Airflow (Shown With the Maximum of Nine Origin200 or Origin Vault Units)

Cable Routing for SGI 2000-Series, Origin Peripherals, and Onyx2 Rack Systems

SGI 2000-series, Origin Peripherals, and Onyx2 rack chassis have an area at the bottom rear of the chassis through which cables may be routed. Figure 8-8 shows the dimensions of the opening and its location relative to the edges of the chassis. In installations with raised floors, it may be desirable to have a hole in the tile below the cutout. Figure 8-8 shows such a hole.

There are some important precautions, however:

- Make sure that the edges of any such hole are not sharp or rough, and will not damage the cables.
- Be careful that the hole in the tile does not reduce the strength of the raised floor.
- Since the casters are very close to the cutout, ensure that none of the casters fall into the hole, potentially causing the system to tip.

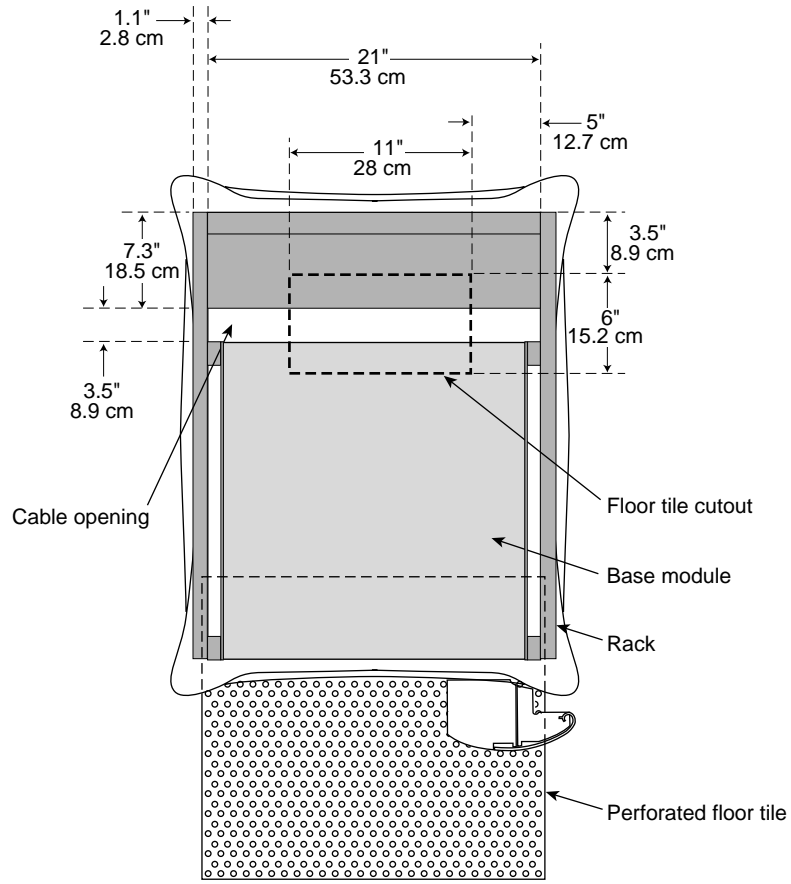

Figure 8-8 SGI 2000-Series, Origin Peripherals, and Onyx2 Rack-Chassis Cable Opening, Raised-Floor Cutout, and Perforated Tile

Selecting a Location for Multiple SGI 2000-Series, Origin Peripherals, or Onyx2 Rack Systems

In selecting a location for multiple SGI 2000-series, Origin Peripherals, or Onyx2 rack systems, first read the information in “Selecting a Location for a Single SGI 2000-Series, Origin Peripherals, or Onyx2 Rack System” on page 82. The information in that section applies to each of the racks in a multi-rack installation.

When multiple SGI 2000-series or Onyx2 rack chassis are installed in the same location, and are connected with CrayLink or XTown cables, there are some additional requirements, which are detailed in this section.

Grounding Multiple SGI 2000-Series or Onyx2 Rack Systems

Multiple SGI 2000-series or Onyx2 rack systems must be connected with special grounding straps supplied by SGI for this purpose. These ensure that the chassis maintain the same chassis ground, a factor that is very important for systems connected with CrayLink or XTown cables.

Consult with your system support engineer (SSE) for further information about chassis-to-chassis grounding.



Warning: Any difference in ground potential greater than 500 millivolts (0.5 volts) between two chassis connected with CrayLink or XTown cables can cause a range of problems, from poor system operation to severe equipment damage. For further information, see “Chassis Branch Circuit Grounding” on page 119.

CrayLink Cabling Multiple SGI 2000-Series or Onyx2 Rack Systems

SGI 2000-series or Onyx2 rack systems connected with CrayLink cables not only must be grounded to each other, they also must be located exactly in the relative positions planned by the cable designers.

Multiple SGI 2000-Series or Onyx2 Rack System Recommended Clearances

Approved multiple rack-chassis configurations are illustrated in Figure 8-9 through Figure 8-11. Other layouts may be acceptable. For information, consult your SSE.

Note: Large multi-rack configurations typically require a meta-router chassis, as shown in Figure 8-11. Consult your SSE for details.

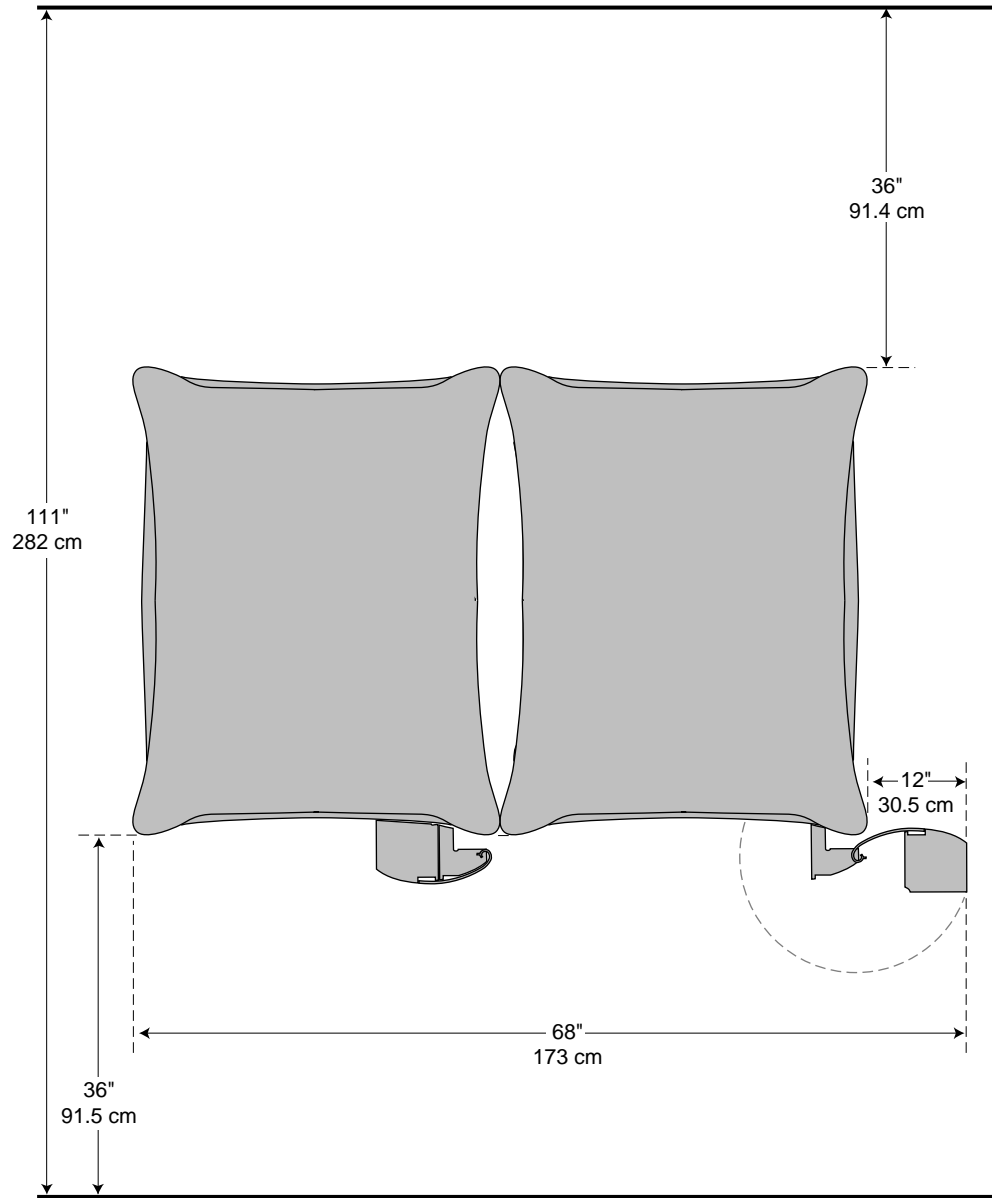

Figure 8-9 Two-Chassis SGI 2000-Series, Origin Peripherals, or Onyx2 Rack Recommended Clearances

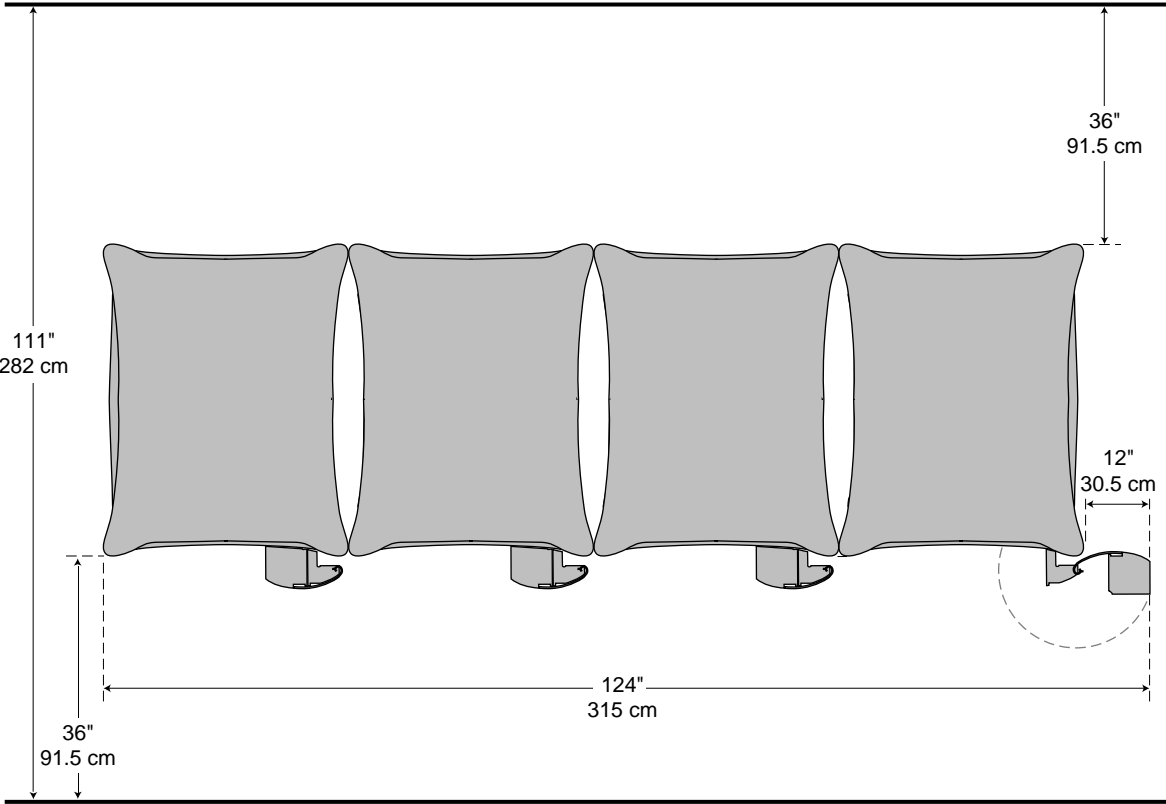

Figure 8-10 Four-Chassis SGI 2000-Series, Origin Peripherals, or Onyx2 Rack Recommended Clearances

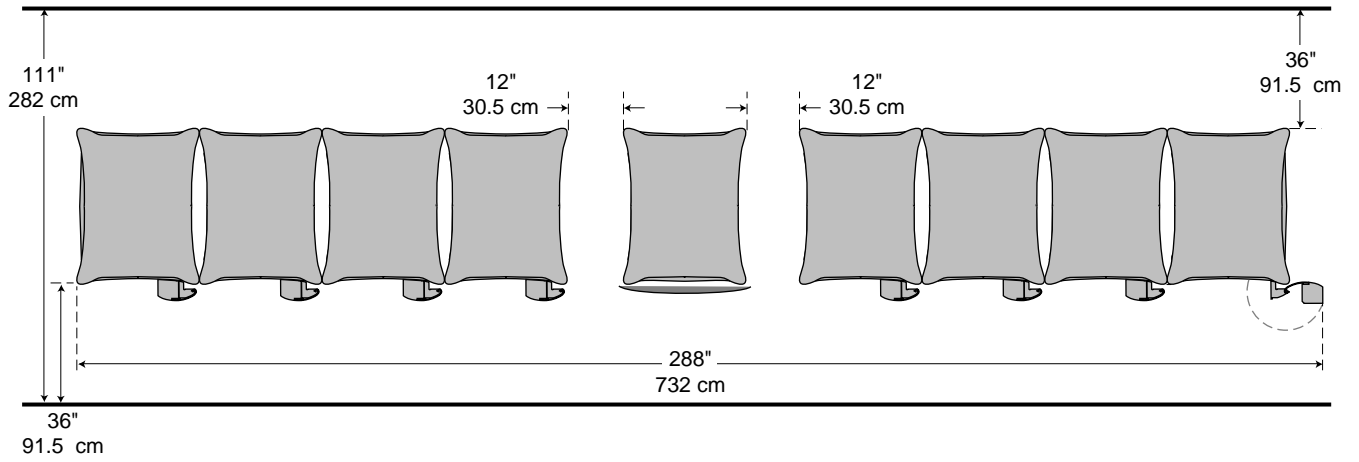

Figure 8-11 Nine-Chassis SGI 2000-Series or Onyx2 Rack Recommended Clearances (Center Chassis is a Meta-Router)

SGI 2000-Series, Origin Peripherals, and Onyx2 Rack Chassis Internal Wiring

SGI 2000-series, Onyx2, Origin200, and Origin Vault rack-chassis systems contain a power distribution unit (PDU) which looks much like a common power strip, only larger. The PDUs in racks designed for SGI 2000-series and Onyx2 modules have two 20-amp receptacles and six 15-amp receptacles. The PDUs in racks designed for Origin200 and Origin Vault units have nine 15-amp receptacles. The various types of PDUs are illustrated in “SGI 2000-Series, Origin Peripherals, and Onyx2 Rack Power Distribution Units (PDUs)” on page 139.



Warning: Any difference in ground potential greater than 500 millivolts (0.5 volts) between two chassis connected with CrayLink or XTown cables can cause a range of problems, from poor system operation to severe equipment damage. For further information, see “Chassis Branch Circuit Grounding” on page 119.

Note: All SGI 2000-series, Onyx2, Origin200, and Origin Vault racks are designed to run on 208 volts (nominal), single-phase power (see “Voltage Requirements” on page 13).

The power distribution unit in each rack then supplies power to the base modules contained within that rack. For additional details about the power requirements of these modules, see “SGI 2000-Series Base Module Power and Cooling Requirements” on page 62 and “Onyx2 Deskside System Power and Cooling Requirements” on page 66.

Onyx2 graphics insert modules used in rack Onyx2 systems have their own power cable which connects directly to a 30-amp receptacle rather than going through the PDU in the rack.

The rack PDUs are illustrated and described in “Power Cables and Connectors” on page 129.

SGI 2000-Series Rack Chassis Site Requirements

For information about selecting a physical location for an SGI 2000-series rack system, see "Selecting a Location for an SGI 2000-Series, Origin Peripherals, or Onyx2 Rack System" on page 81.

SGI 2000-Series Rack Chassis Specifications

Table 8-1 lists the physical specifications of the SGI 2000-series rack chassis.

Table 8-1 SGI 2000-Series Rack Physical Specifications

Dimensions		
Installed:	length	38.5" (97.8 cm)
	width	28" (71.1 cm)
	height	73" (185 cm)
Shipping:	length	48.6" (124 cm)
	width	47.6" (121 cm)
	height	81" (206 cm)
Weight:	minimum (empty rack)	300 lbs (136 kg)
	maximum (full rack)	750 lbs (340 kg)
	shipping (maximum)	900 lbs (408 kg)
Floor Loading:	minimum	38 lb/ft ² (185 kg/m ²)
	maximum	95 lb/ft ² (466 kg/m ²)
Air Temperature		
Operating:	0-5,000 ft	41° to 95° F (5° to 35° C)
	5,000-10,000 ft	41° to 86° F (5° to 30° C)
Non-Operating:		-4° to 140° F (-20° to 60° C)
Thermal Gradient:	maximum	18° F (10° C) per hour

Table 8-1 (continued) SGI 2000-Series Rack Physical Specifications

Altitude:	operating	10,000 ft (3,048 m) MSL (maximum)
	non-operating	40,000 ft (12,192 m) MSL (maximum)
Relative Humidity:	operating	10-90% (non-condensing)
	non-operating	10-95% (non-condensing)
Humidity Gradient	maximum	10% relative humidity per hour
Acoustics:	typical	55 dBa
Vibration:	maximum, sustained	0.01", 5-10 Hz; 0.1 G 10-500 Hz (operating)
	maximum, peak	0.02", 5-10 Hz; 0.1 G 10-500 Hz (operating)
	sensitive frequency	8-33 Hz (varies with configuration)

SGI 2000-Series Rack Chassis Power and Cooling Requirements

Table 8-2 provides power consumption and cooling requirements for the SGI 2000-series rack chassis. For formulas, descriptions, and general information about power and cooling, refer to "Electrical Requirements" on page 13 and "Thermal Requirements" on page 17.

The SGI 2000-series rack chassis are highly configurable systems, and it is not possible to list the power and cooling requirements for each configuration. For this reason Table 8-2 lists both typical and maximum figures. Note that some systems will draw even less than the "typical" figures listed.

The recommended method of determining power and cooling needs for an SGI 2000-series rack is to use the power and cooling information in "Electrical Requirements" on page 13 and "Thermal Requirements" on page 17, along with the specific information in the following sections:

- "Origin Vault Power and Cooling Requirements" on page 52.
- "SGI 2000-Series Base Module Power and Cooling Requirements" on page 62.

Then calculate the system's requirements.

Caution: SGI 2000-series rack systems are highly configurable, and therefore have an extremely wide range of power and cooling requirements. It is very rare for an SGI 2000-series rack system to reach the “maximum” power and cooling requirements listed in Table 8-2. Ask your SGI representative about particular configurations.

Table 8-2 SGI 2000-Series Rack Power and Cooling Specifications

Volts:		200-240 volts AC, 1-phase
Watts (from-the-wall):	typical maximum	1,900 watts 4,000 watts (see “Caution,” above)
Power Factor:	minimum	0.98
Total Harmonic Dist.:		Varies with configuration
Inrush Current:	peak	420 amps
Frequency:		47-63 Hertz
Cooling Requirements: (Also see “Caution” on page 18)	typical maximum	6,479 Btu/hr (0.54-ton AC load) 13,640 Btu/hr (1.14-ton AC load) (see “Caution,” above)
Airflow Volume:	maximum	800 cfm (0.38 m ³ /s)

See “SGI 2000-Series, Origin Peripherals, and Onyx2 Rack Chassis Internal Wiring” on page 96 for information about the internal wiring for an SGI 2000-series rack.

See Appendix B, “Site Power and Power Cables,” for information about SGI 2000-series site-wiring and power cables.

SGI 2000-Series Rack Chassis External Peripherals

SGI 2000-series rack system have the same external peripheral requirements as the SGI 2000-series and Origin Vault base modules from which they are assembled. See “SGI 2000-Series Base Module External Peripherals” on page 64 and “Origin200 External Peripherals” on page 49 for more information.

SGI 2000-Series Rack Chassis Cabling Requirements

Besides power cables and external SCSI peripherals, SGI 2000-series rack systems are typically connected to network cables, serial devices, and so on. For details of the ports found on an SGI 2000-series rack system, see the *Origin2000 Rackmount Owner’s Guide*.

In addition, SGI 2000-series rack chassis with more than one base module contain CrayLink connections.

Origin Peripherals Rack Chassis Site Requirements

For information about selecting a physical location for an Origin Peripherals rack chassis, see "Selecting a Location for an SGI 2000-Series, Origin Peripherals, or Onyx2 Rack System" on page 81.

Origin Peripherals Rack Chassis Specifications

Table 8-3 lists the physical specifications of the Origin Peripherals rack chassis.

Table 8-3 Origin Peripherals Rack Physical Specifications

Dimensions		
Installed:	length	38.5" (97.8 cm)
	width	28" (71.1 cm)
	height	73" (185 cm)
Shipping:	length	48.6" (124 cm)
	width	47.6" (121 cm)
	height	81" (206 cm)
Weight:	minimum (empty rack)	300 lbs (136 kg)
	maximum (full rack)	750 lbs (340 kg)
	shipping (maximum)	900 lbs (408 kg)
Floor Loading:	minimum	38 lb/ft ² (185 kg/m ²)
	maximum	95 lb/ft ² (466 kg/m ²)
Air Temperature		
Operating:	0-5,000 ft	41° to 95° F (5° to 35° C)
	5,000-10,000 ft	41° to 86° F (5° to 30° C)
Non-Operating:		-4° to 140° F (-20° to 60° C)
Thermal Gradient:	maximum	18° F (10° C) per hour

Table 8-3 (continued) Origin Peripherals Rack Physical Specifications

Altitude:	operating	10,000 ft (3,048 m) MSL (maximum)
	non-operating	40,000 ft (12,192 m) MSL (maximum)
Relative Humidity:	operating	10-90% (non-condensing)
	non-operating	10-95% (non-condensing)
Humidity Gradient	maximum	10% relative humidity per hour
Acoustics:	typical	55 dBa
Vibration:	maximum, sustained	0.01", 5-10 Hz; 0.1 G 10-500 Hz (operating)
	maximum, peak	0.02", 5-10 Hz; 0.1 G 10-500 Hz (operating)
	sensitive frequency	8-33 Hz (varies with configuration)

Origin Peripherals Rack Chassis Power and Cooling Requirements

Table 8-4 provides power consumption and cooling requirements for the Origin Peripherals rack chassis. For formulas, descriptions, and general information about power and cooling, refer to “Electrical Requirements” on page 13 and “Thermal Requirements” on page 17.

The Origin Peripherals rack chassis are highly configurable systems, and it is not possible to list the power requirements for each configuration. For this reason Table 8-2 lists only maximum figures.

The recommended method of determining power and cooling needs for an Origin Peripherals rack is to use the power and cooling information in “Electrical Requirements” on page 13 and “Thermal Requirements” on page 17, along with the specific information in the following sections:

- “Origin200 Power and Cooling Requirements” on page 48.
- “Origin Vault Power and Cooling Requirements” on page 52.

Then calculate the system’s requirements.

Caution: Origin Peripherals rack chassis are highly configurable, and therefore have an extremely wide range of power and cooling requirements. It is very rare for an Origin Peripherals rack chassis to reach the power and cooling requirements listed under “maximum” in Table 8-4. **SGI strongly recommends that you calculate the power requirements for your particular system, as described above.** You may also ask your SGI representative about particular configurations.

Table 8-4 Origin Peripherals Rack Power and Cooling Specifications

Volts:		200-240 volts AC, 1-phase
Watts (from-the-wall):	typical maximum	Depends on configuration 5,400 watts maximum (see “Caution,” above)
Power Factor:	minimum	0.98
Total Harmonic Dist.:		Varies with configuration
Inrush Current:		Varies with configuration, but can reach 1260 amps peak (see “Caution,” above)
Frequency:		47-63 Hertz
Cooling Requirements: (Also see “Caution” on page 18)	typical maximum	Depends on configuration 18,414 Btu/hr (1.53-ton AC load) (see “Caution,” above)
Airflow Volume:	maximum	900 cfm (0.42 m ³ /s)

See “SGI 2000-Series, Origin Peripherals, and Onyx2 Rack Chassis Internal Wiring” on page 96 for information about the internal wiring for an Origin Peripherals rack.

See Appendix B, “Site Power and Power Cables,” for information about Origin Peripherals rack site-wiring and power cables.

Origin Peripherals Rack Chassis External Peripherals

Origin Peripherals rack system have the same external peripheral requirements as the Origin200 modules from which they are assembled. See “Origin200 External Peripherals” on page 49 for more information.

Origin Peripherals Rack Chassis Cabling Requirements

Besides power cables and external SCSI peripherals, Origin Peripheral rack chassis containing Origin200 systems are typically connected to network cables, serial and parallel devices, and so on. For more information, see “Origin200 Cabling Issues” on page 50.

In addition, Origin Peripheral rack chassis containing Origin200 systems may contain CrayLink connections. For more information, see “Origin200 Cabling Issues” on page 50.

Besides power cables, Origin Peripheral rack chassis containing Origin Vault units will typically be connected via SCSI cables to one or more nearby computer systems. For more information, see “Origin Vault SCSI-Cable Considerations” on page 53.

Onyx2 Rack Chassis Site Requirements

For information about selecting a physical location for a Silicon Graphics Onyx2 rack system, see "Selecting a Location for an SGI 2000-Series, Origin Peripherals, or Onyx2 Rack System" on page 81.

Onyx2 Rack Chassis Specifications

Table 8-5 lists the physical specifications of the Silicon Graphics Onyx2 rack chassis.

Table 8-5 Onyx2 Rack Physical Specifications

Dimensions		
Installed:	length	38.5" (97.8 cm)
	width	28" (71.1 cm)
	height	73" (185 cm)
Shipping:	length	48.6" (124 cm)
	width	47.6" (121 cm)
	height	81" (206 cm)
Weight:	minimum (empty rack)	300 lbs (136 kg)
	maximum (full rack)	750 lbs (340 kg)
	shipping (maximum)	900 lbs (408 kg)
Floor Loading:	minimum	38 lb/ft ² (185 kg/m ²)
	maximum	95 lb/ft ² (466 kg/m ²)
Air Temperature		
Operating:	0-5,000 ft	41° to 95° F (5° to 35° C)
	5,000-10,000 ft	41° to 86° F (5° to 30° C)
Non-Operating:		-4° to 140° F (-20° to 60° C)
Thermal Gradient:	maximum	18° F (10° C) per hour

Table 8-5 (continued) Onyx2 Rack Physical Specifications

Altitude:	operating	10,000 ft (3,048 m) MSL (maximum)
	non-operating	40,000 ft (12,192 m) MSL (maximum)
Relative Humidity:	operating	10-90% (non-condensing)
	non-operating	10-95% (non-condensing)
Humidity Gradient:	maximum	10% relative humidity per hour
Acoustics:	typical	55 dBa
Vibration:	maximum, sustained	0.01", 5-10 Hz; 0.1 G 10-500 Hz (operating)
	maximum, peak	0.02", 5-10 Hz; 0.1 G 10-500 Hz (operating)
	sensitive frequency	8-33 Hz (varies with configuration)

Onyx2 Rack Chassis Power and Cooling Requirements

Table 8-6 provides power consumption and cooling requirements for the Silicon Graphics Onyx2 rack chassis. For formulas, descriptions, and general information about power and cooling, refer to “Electrical Requirements” on page 13 and “Thermal Requirements” on page 17.

The Silicon Graphics Onyx2 rack chassis are highly configurable systems, and it is not possible to list the power and cooling requirements for each configuration. For this reason Table 8-6 lists both typical and maximum figures. Note that some systems will draw even less than the “typical” figures listed.

The recommended method of determining power and cooling needs for a Silicon Graphics Onyx2 rack is to use the power and cooling information in “Electrical Requirements” on page 13 and “Thermal Requirements” on page 17, along with the specific information in the following sections:

- “Origin Vault Power and Cooling Requirements” on page 52.
- “SGI 2000-Series Base Module Power and Cooling Requirements” on page 62.
- “Onyx2 Graphics Insert Module Power and Cooling Requirements” on page 75.

Then calculate the system’s requirements.

Caution: Silicon Graphics Onyx2 rack systems are highly configurable, and therefore have an extremely wide range of power and cooling requirements. It is very rare for a Silicon Graphics Onyx2 rack system to reach the power and cooling requirements listed under “maximum” in Table 8-6. Ask your SGI representative about particular configurations.

Table 8-6 Onyx2 Rack Power and Cooling Specifications

Volts:		200-240 volts, 1-phase
Watts (from-the-wall):	typical maximum	2,250 watts 4,300 watts (see “Caution,” above)
Power Factor:	minimum	0.98
Total Harmonic Dist.:		Varies with configuration
Inrush Current:	peak	420 amps
Frequency:		47-63 Hertz
Cooling Requirements: (Also see “Caution” on page 18)	typical maximum	7,673 Btu/hr (0.64-ton AC load) 14,663 Btu/hr (1.22-ton AC load) (see “Caution,” above)
Airflow Volume:	maximum	900 cfm (0.42 m ³ /s)

See “SGI 2000-Series, Origin Peripherals, and Onyx2 Rack Chassis Internal Wiring” on page 96 for information about the internal wiring for a Silicon Graphics Onyx2 rack.

See Appendix B, “Site Power and Power Cables,” for information about Silicon graphics Onyx2 site-wiring and power cables.

Onyx2 Rack Chassis External Peripherals

Silicon Graphics Onyx2 rack systems have the same external peripheral requirements as Silicon Graphics Onyx2 base modules. See “Onyx2 Deskside System External Peripherals” on page 68 for more information.

Onyx2 Rack Chassis Cabling Requirements

Besides power cables and external SCSI peripherals, Silicon Graphics Onyx2 rack systems are typically connected to network cables, serial and parallel devices, and so on. For details of the ports found on a Silicon Graphics Onyx2 rack system, see the *Onyx2 Rackmount Owner's Guide*.

In addition, Silicon Graphics Onyx2 rack chassis with more than one base module contain CrayLink connections, and each Silicon Graphics Onyx2 graphics insert module connects to an SGI 2000-series base module with an XTown cable.

Site Preparation for External Peripherals

This appendix provides information about external peripherals used with SGI 2000-series, Onyx2, Origin200, Octane, and O2 systems.

Monitors

SGI workstations, and some SGI servers, connect to a video monitor. With Onyx2, SGI has introduced a new monitor, quite different from previous designs (see Figure A-1). Since SGI workstations are compatible with a wide range of monitors, specifications are also included here for some commonly used sizes: 16-inch, 19-inch, and 21-inch.

The monitor(s) must be located within cabling distance of the main chassis. The length of the standard monitor cable depends on the system being installed. The desktop systems typically ship with a 6-foot cable, while the deskside and rack systems may come with a cable of up to 30 feet in length. In either case, longer cables may be available.

If a keyboard (or other input device) will be associated with the monitor, the length of the cable from the main chassis to that device may present more of a distance limitation than the monitor cable itself.

If several monitors will be positioned in one area, maintain a minimum distance of three feet between monitors to eliminate visual artifacts on the monitor screens caused by electromagnetic interference (EMI).

Allow sufficient space to connect a cable to the monitor, particularly when using a cable with a DB13W3 connector and EMI filters. To reduce the possibility of signal reflection in a monitor cable, keep all bends in the cable to less than 90 degrees. If a cable must be bent at 90 degrees, keep the inside radius of the bend to a minimum of 3 inches.

Note: It is important that monitor placement conform to ergonomic standards. Check local regulations to ensure that the site complies with ergonomic, worksite, and related codes.

Table A-1 summarizes the monitor physical characteristics.

Table A-1 Monitor Physical Specifications

		17" Monitor	20" Monitor	21" Monitor	24" Monitor
Dimensions:					
Installed:	length	17.7" (45 cm)	19.7" (50 cm)	21.4" (54.3 cm)	21.3" (54 cm)
	width	15.7" (39.9 cm)	18.5" (47 cm)	19.7" (50 cm)	22.8" (58 cm)
	height	16.1" (40.9 cm)	18.5" (47 cm)	18.4" (46.7 cm)	19.7" (50 cm)
Shipping:	length	22.1" (56.2 cm)	27" (68.6 cm)	25" (63.5 cm)	29.9" (76 cm)
	width	23.2" (59 cm)	25" (63.5 cm)	27.8" (70.6 cm)	31.1" (79 cm)
	height	24" (61 cm)	25" (63.5 cm)	25.5" (65 cm)	30.5" (77.5 cm)
Weight:	installed	50 lbs (23 kg)	69 lbs (31 kg)	79 lbs (36 kg)	90 lbs (41 kg)
	shipping	60 lbs (27 kg))	80 lbs (36 kg)	90 lbs (41 kg)	102 lbs (46 kg)
Power:		127 watts	120 watts	109 watts	175 watts
Inrush Current:					< 80 amps
Cooling:		433 Btu/hr	410 Btu/hr	371 Btu/hr	597 Btu/hr
Altitude (maximum):	operating		10,000 ft (3080 m) MSL		
	non-operating		40,000 ft (12320 m) MSL		
Humidity:	operating		10-90% (non-condensing)		
	non-operating		10-95% (non-condensing)		
Vibration (operating):	max. sustained		0.01", 5-10 Hz; 0.1 G 10-500 Hz (operating)		
	max. peak		0.02", 5-10 Hz; 0.1 G 10-500 Hz (operating)		
	sensitive freq.		8-33 Hz (varies with configuration)		

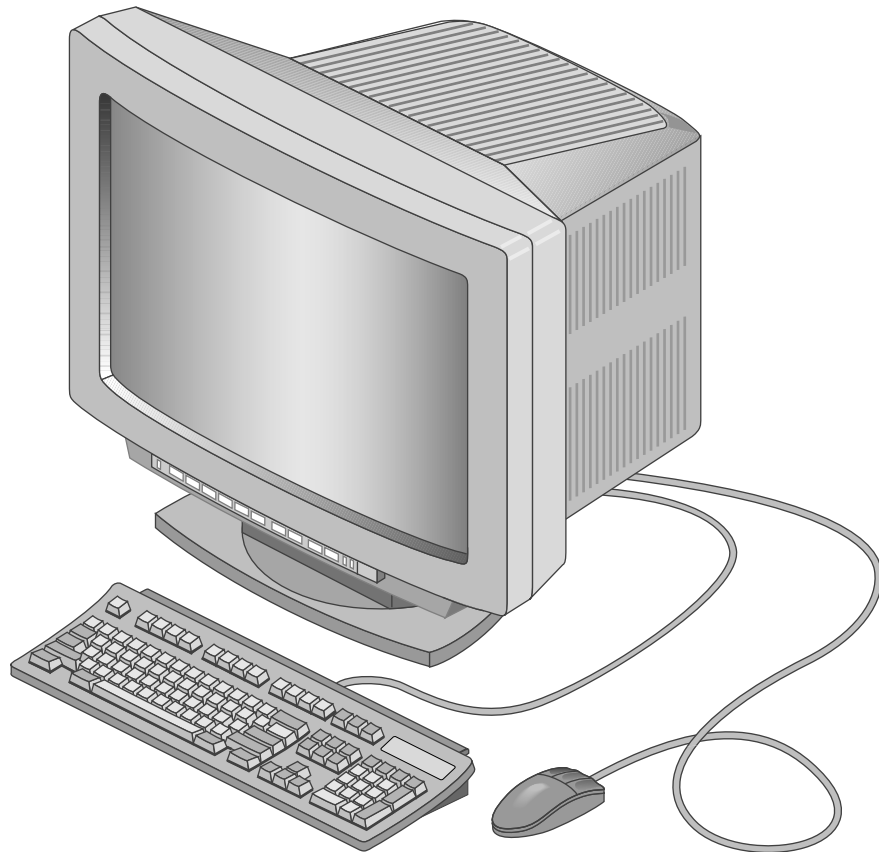

Figure A-1 Sony 24" "Superwide" Monitor (Shown With Keyboard and Mouse)



Warning: The Sony D-M24G superwide monitor is very heavy. You need two people to move it.

Keyboards

SGI workstations use keyboards for input. O2, Octane, and Onyx2 computer systems use an industry-standard PS/2 style keyboard.

The keyboard must be located within cabling distance of the chassis.

PS/2 style keyboards typically have a permanently connected 6-foot cable. Extension cables are commercially available, typically in the 6- to 10-foot range.

Note: It is important that keyboard placement conform to ergonomic standards. Check local regulations to ensure that the site complies with ergonomic, worksite, and related codes.

Mice

SGI workstations use mice as pointing devices. O2, Octane, and Onyx2 computer systems use an industry-standard PS/2 style mouse.

The mouse must be located within cabling distance of the chassis. PS/2 style mice typically have a permanently connected 6-foot cable. Extension cables are commercially available, typically in the 6- to 10-foot range.

Note: It is important that mouse placement conform to ergonomic standards. Check local regulations to ensure that the site complies with ergonomic, worksite, and related codes.

External SCSI Devices

SGI computer systems may be connected to many different types of external SCSI devices, such as disks, tape drives, CD-ROM drives, RAID devices, tape libraries, printers, scanners, and modem servers.

In addition to the SCSI devices listed above, the systems described in this guide can be connected to an Origin Vault chassis. For further information, see "Origin Vault Site Requirements" on page 51.

The systems described in this document may have either single-ended or differential SCSI buses. Single-ended SCSI has a maximum bus length of 3 meters, and differential SCSI has a maximum bus-length of 25 meters. These lengths, however, include all portions of the SCSI cable, both inside and outside the chassis. Where possible, it is best to keep SCSI buses well below these rated maximum lengths.

The SCSI cables will probably not run in a straight line from the host system's SCSI port to the external SCSI device. Instead, they may run under a floor, or around systems. In this way, systems with a straight-line distance that is well within the limitations of the SCSI bus may, in fact, be too far apart.

Consider all of these factors when choosing a site for an external SCSI peripheral.

ASCII Terminals

SGI servers are typically operated via an industry-standard serial ASCII terminal. In some cases, serial ASCII terminals are connected to workstations.

The terminal is typically connected with a standard serial cable. Serial cables are available in various lengths, up to several hundred feet. It is convenient, however, to have the terminal near the server.

In some cases, one terminal may be used for a number of servers. In these cases, a serial switchbox saves the trouble of recabling every time you need to change servers.

SGI servers work with a large variety of serial ASCII terminals. It would be impossible to list the physical specifications of all of them here.

It is also common to use a laptop computer running a terminal-emulation program in place of a serial ASCII terminal.

Note: Unlike the CHALLENGE and Onyx product line, the O2, Octane, Origin200, SGI 2000-series, and Onyx2 products have industry-standard (PC-style) 9-pin serial connectors. This means that to connect a serial ASCII terminal, you need a standard 9-pin to 25-pin serial cable. The cables used with older SGI products do not work.

Site Power and Power Cables

This appendix contains site-wiring requirements and power-cord specifications for SGI 2000-series, Onyx2, Origin200, Origin Vault, Octane, and O2 systems.

To determine the power requirements of a particular system, refer to the appropriate chapter in the main body of this guide. Once you know the system configuration and power requirements, use this appendix to determine the wiring details needed by a licensed electrician.

This appendix is separated into two main sections:

- site wiring
- power cords.



Warning: Any chassis connected with CrayLink or XTown cables must have ground potentials within 500 millivolts (0.5 volts) of each other. Grounding variations larger than 500 millivolts will damage the CrayLink or XTown cables and/or the network boards.



Warning: A licensed electrician should perform all wiring to ensure that the installation meets local and country electrical codes.

Installing Site Power Circuits

This section describes how to install the site's power wiring by performing these tasks:

- Reviewing the site's physical requirements
- Wiring the main circuit
- Wiring the chassis branch circuits.

Reviewing the Site's Physical Requirements

Ensure that power outlets are within the maximum cabling distance from the chassis and monitors. Monitors require their own power outlet, since the chassis do not provide any peripheral power outlets. The typical power cable length is 10 feet. See "Power Cables and Connectors" on page 129 for more details on power cables.

Maximum cable lengths are based on the wire gauge of the standard power cables. Consult a licensed electrician to determine the wire gauge for custom power cables.

Make sure that power cables are properly routed and protected from damage, particularly in areas frequented by people. Check the cabling plans to verify that sufficient length is allowed for proper slack through all routing, especially for indirect routing that runs cables under floors, along walls, or in ceiling cable trays.

If an existing main power circuit is selected for the new equipment, check the circuit for any electrical noise-generating equipment, such as motors, calculators, and typewriters, and transfer these devices to a circuit other than ones servicing computer equipment.

For all but the simplest installations, create a power budget and wiring scheme that considers both existing equipment and future expansion. Considerations include:

- an emergency power off (EPO) switch for disconnecting power to the main circuitry, with the controls located near the primary exit doors (see "Emergency Power-Off Switch" on page 146 for more information).
- convenience outlets for test and auxiliary devices
- equipment and safety ground conductors sized on the basis of the ampere rating of the overcurrent device protecting the circuit conductors.
- on critical production equipment, the installation of UPS or SPS power protection (see "Power-Line Treatment" on page 147 for more information).

Wiring the Main Circuit

Evaluate the quality of the power supplied by the local power company. Reliable computer operation requires power that is mostly free of fluctuations, transients, surges and spikes, and noise. If the local power quality is questionable, line conditioning equipment may be required (see “Power-Line Treatment” on page 147 for further information).

Install a main circuit panel with properly rated circuit breakers for each branch circuit. Consider adding an emergency power shutdown control to this main panel, as discussed in “Emergency Power-Off Switch” on page 146. Figure B-1 shows the wiring for a main circuit panel.



Warning: A licensed electrician should perform all wiring to ensure that the installation meets local and country electrical codes.

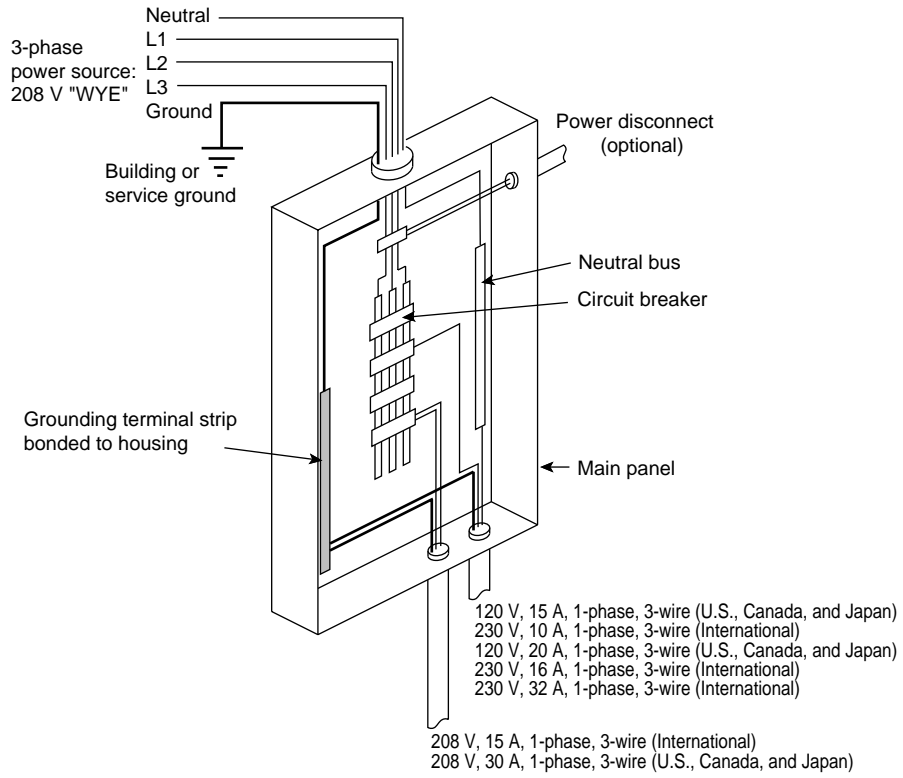

Figure B-1 Main Circuit Wiring

Wiring Chassis Branch Circuits

All chassis connected with CrayLink or XTown cables should be powered from the same electrical distribution panel to minimize differences in ground potential. The individual branch circuits should be equipped with their own circuit breaker, and should be wired according to the diagrams in Figures B-3 through B-9.

Phase Balancing

As shown in Figures B-3 through B-9, the power receptacles on the individual branch circuits may be distributed across the three phases of the AC power to more equally balance the electrical load.

Chassis Branch Circuit Grounding

Grounding requirements are very important in SGI 2000-series and Onyx2 systems. Each chassis must be well grounded, from the electrical power receptacle, through the electrical distribution panel, all the way back to the electrical service ground electrode. All chassis connected with CrayLink or XTown must share the same transformer and must be connected to the same grounding electrodes. See Figure B-2 for correct and incorrect chassis-grounding examples.

If you have any doubts about the quality of the ground connection, it is important that you consult with a qualified electrician.



Warning: Any difference in ground potential greater than 500 millivolts (0.5 volts) between two chassis connected with CrayLink or XTown cables can cause a range of problems, from poor system operation to severe equipment damage.

The branch circuit wiring should have an insulated grounding conductor that is identical in size, insulation material, and thickness to the earthed and unearthed branch-circuit supply conductors. The grounding conductor should be green, with or without one or more yellow stripes. This grounding, or earthing, conductor should be connected to earth at the service equipment or, if the power is supplied by a separately derived system, it should be connected to earth at the supply transformer or at the motor-generator.

All installed power receptacles for these systems should be of an earthing type, and the grounding, or earthing, conductors serving these receptacles should be connected to earth at the service equipment.

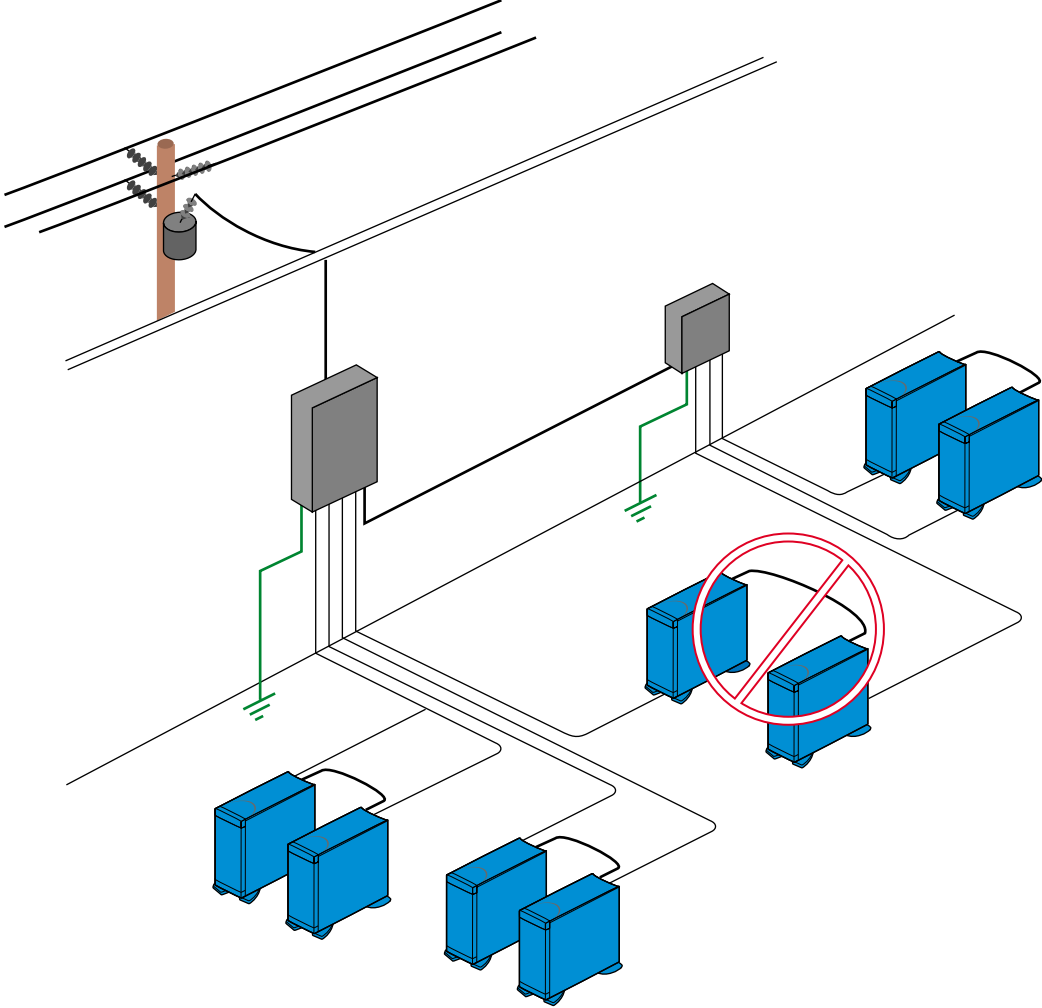

Figure B-2 Correct and Incorrect Chassis Grounding Examples (Origin200 Systems Shown, Other Systems Similar)

Wiring O2, Octane, Origin200, and Origin Vault Chassis Branch Circuits

Chassis branch circuits for O2, Octane, Origin200, and Origin Vault systems should be wired as shown in Figure B-3 (U.S., Canada, and Japan) or Figure B-4 (International).

Note: O2, Octane, Origin200, and Origin Vault systems in the U.S., Canada, and Japan only need 120-volt power at 15 amps (as shown in Figure B-3). However, chassis branch circuits for these systems may also be wired for 120-volt power at 20 amps (as shown in Figure B-5) or 208-volt power at 20 amps (as shown in Figure B-6), in which case, it would be necessary to use a different power cord.

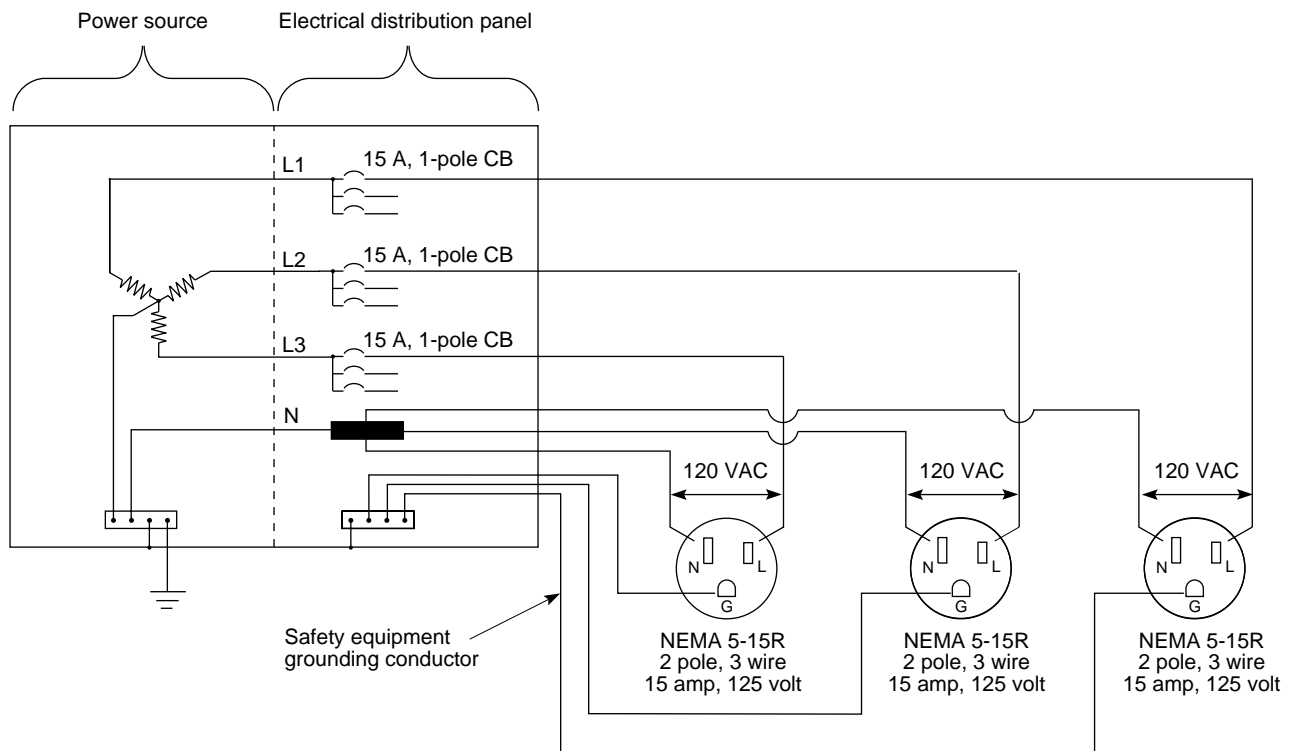

Figure B-3 Chassis Branch Circuit Diagram for 120 VAC, 15 amp, 3-wire, 1-phase (U.S., Canada, and Japan)

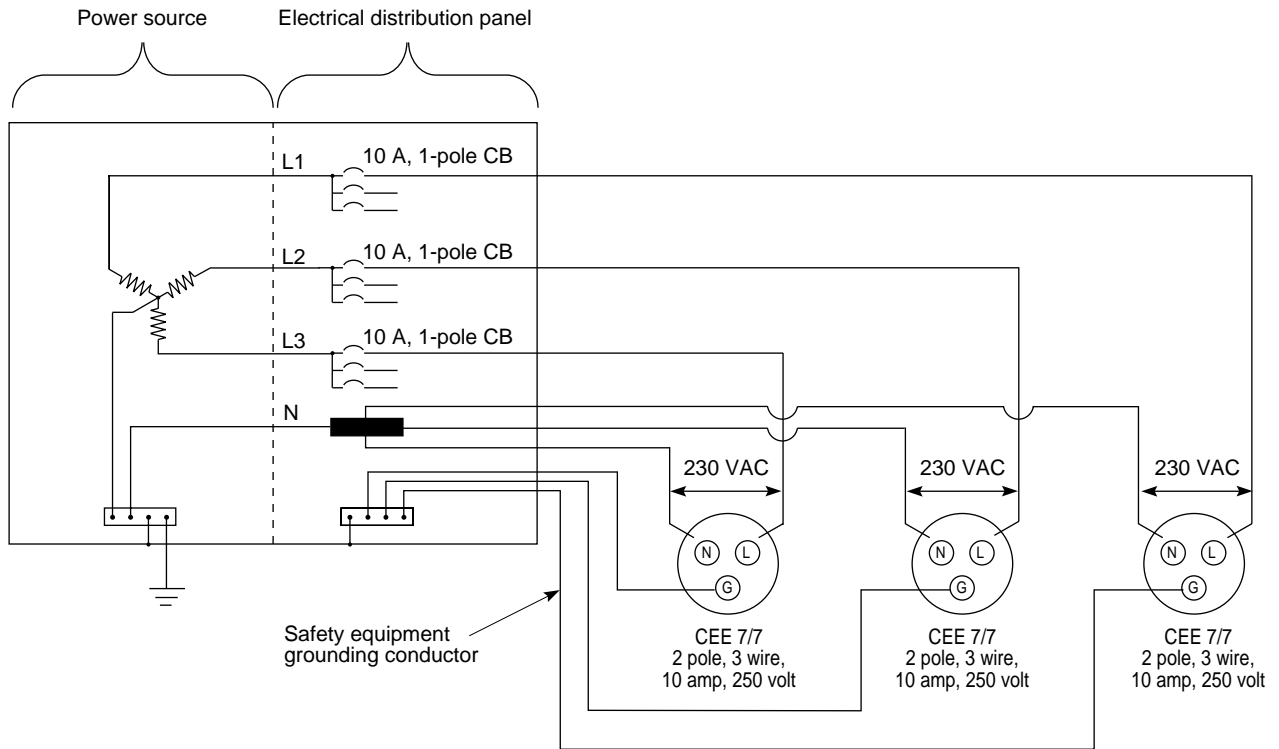

Figure B-4 Chassis Branch Circuit Diagram for 230 VAC, 10 amp, 3-wire, 1-phase (International)

Wiring SGI 2000-Series Deskside and Onyx2 Deskside Chassis Branch Circuits

Chassis branch circuits for SGI 2000-series deskside and Onyx2 deskside 120-volt systems should be wired as shown in Figure B-5 (U.S. and Canada). SGI 2000-series deskside and Onyx2 deskside systems in Japan must use 208-volt power, as shown in Figure B-6.

Note: O2, Octane, Origin200, and Origin Vault systems in the U.S., Canada, and Japan only need 120-volt power at 15 amps (as shown in Figure B-3). However, chassis branch circuits for these systems may also be wired for 120-volt power at 20 amps (as shown in Figure B-5) or 208-volt power at 20 amps (as shown in Figure B-6), in which case, it would be necessary to use a different power cord.

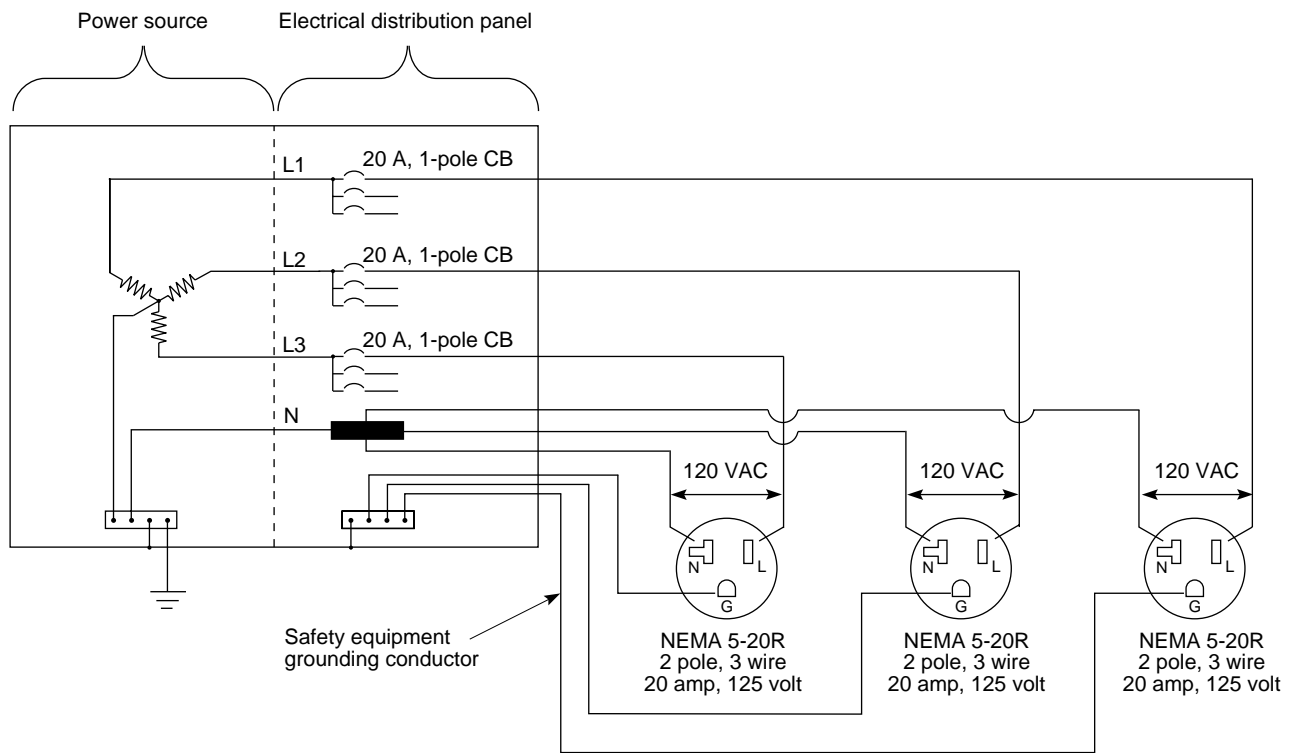

Figure B-5 Chassis Branch Circuit Diagram for 120 VAC, 20 amp, 3-wire, 1-phase (U.S. and Canada)

Chassis branch circuits for SGI 2000-series desktside and Onyx2 desktside 220-volt systems should be wired as shown in Figure B-6 (U.S., Canada, and Japan) or Figure B-7 (International).

Note: O2, Octane, Origin200, and Origin Vault systems in the U.S., Canada, and Japan only need 120-volt power at 15 amps (as shown in Figure B-3). However, chassis branch circuits for these systems may also be wired for 120-volt power at 20 amps (as shown in Figure B-5) or 208-volt power at 20 amps (as shown in Figure B-6), in which case, it would be necessary to use a different power cord.

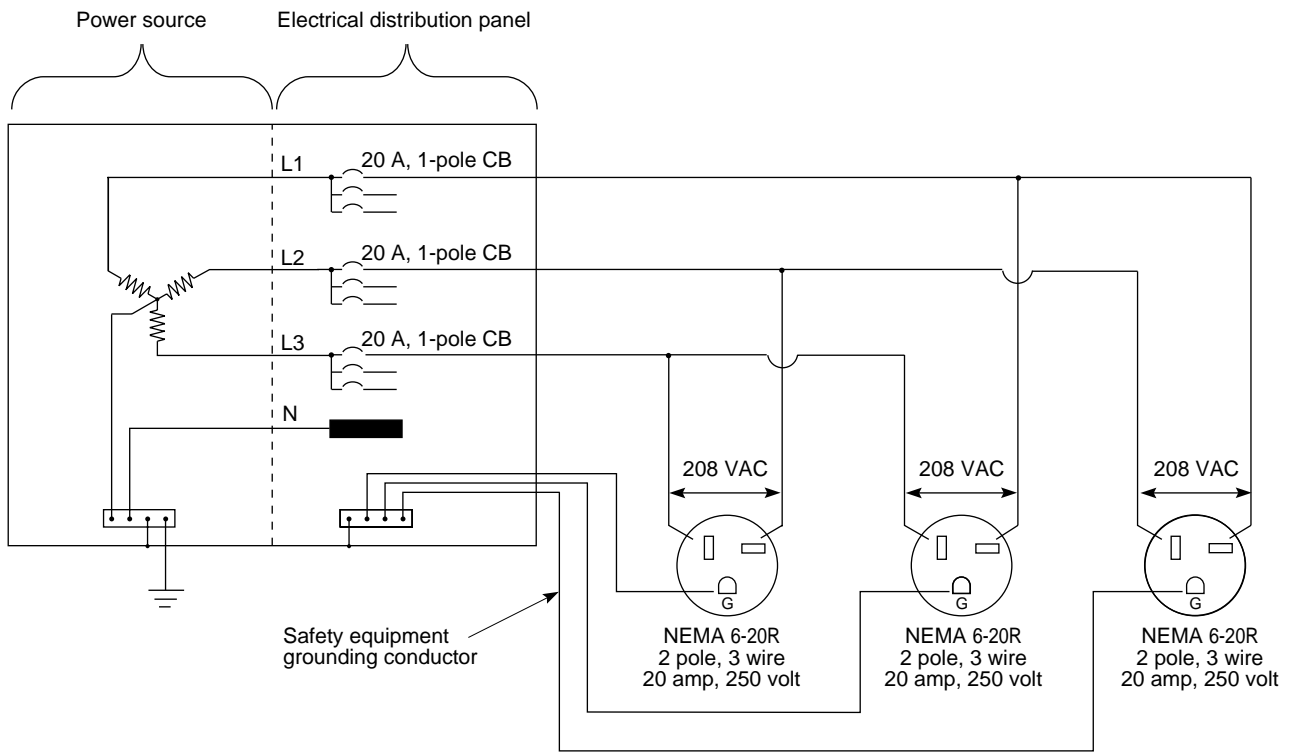

Figure B-6 Chassis Branch Circuit Diagram for 208 VAC, 20 amp, 3-wire, 1-phase (U.S., Canada, and Japan)

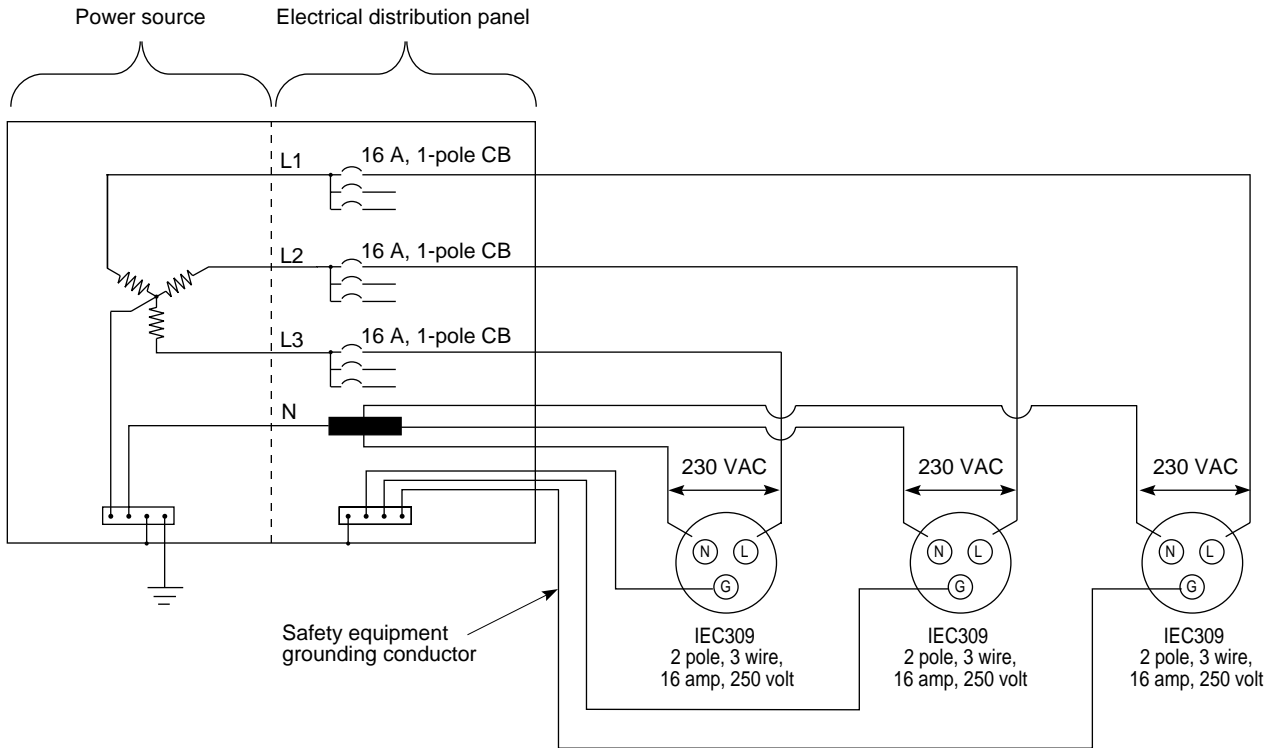

Figure B-7 Chassis Branch Circuit Diagram for 230 VAC, 16 amp, 3-wire, 1-phase (International)

Wiring Rack Chassis Branch Circuits

Chassis branch circuits for SGI 2000-series, Origin200, Origin Vault, and Onyx2 rack systems should be wired as shown in Figure B-8 (U.S., Canada, and Japan) or Figure B-9 (International).

Rack systems draw a large amount of power in a small space. A site for multiple Origin-family rack systems should have one 30- or 32-amp receptacle for each rack (that is, about every two feet). A site for multiple Silicon Graphics Onyx2 rack systems should have two 30- or 32-amp receptacles for each rack (that is, about every foot). This is much denser than the existing wiring at many sites.

If the existing circuit breaker box does not supply enough power, it is important that the site not simply install another circuit breaker box and power some chassis from the original box and some from the new box. Rack chassis in the same system (that is, chassis that are connected with CrayLink or XTown cables) **must** be plugged into branch circuits fed from the same circuit breaker box. It is therefore important that if the existing wiring does not support the expected load, a new circuit breaker box with sufficient capacity for the *entire* multi-rack system be installed.

Note: See the section on grounding requirements, “Chassis Branch Circuit Grounding” on page 119.

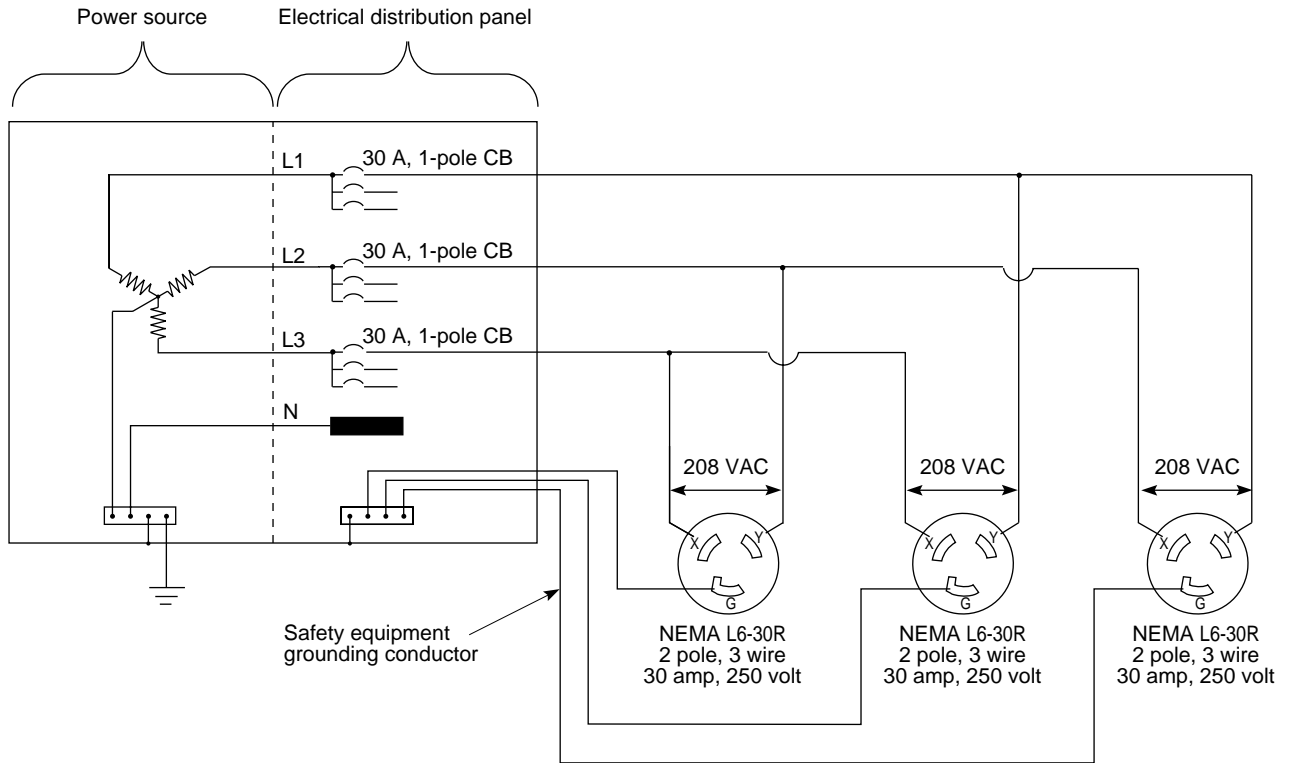

Figure B-8 Chassis Branch Circuit Diagram for 208 VAC, 30 amp, 3-wire, 1-phase (U.S., Canada, and Japan)

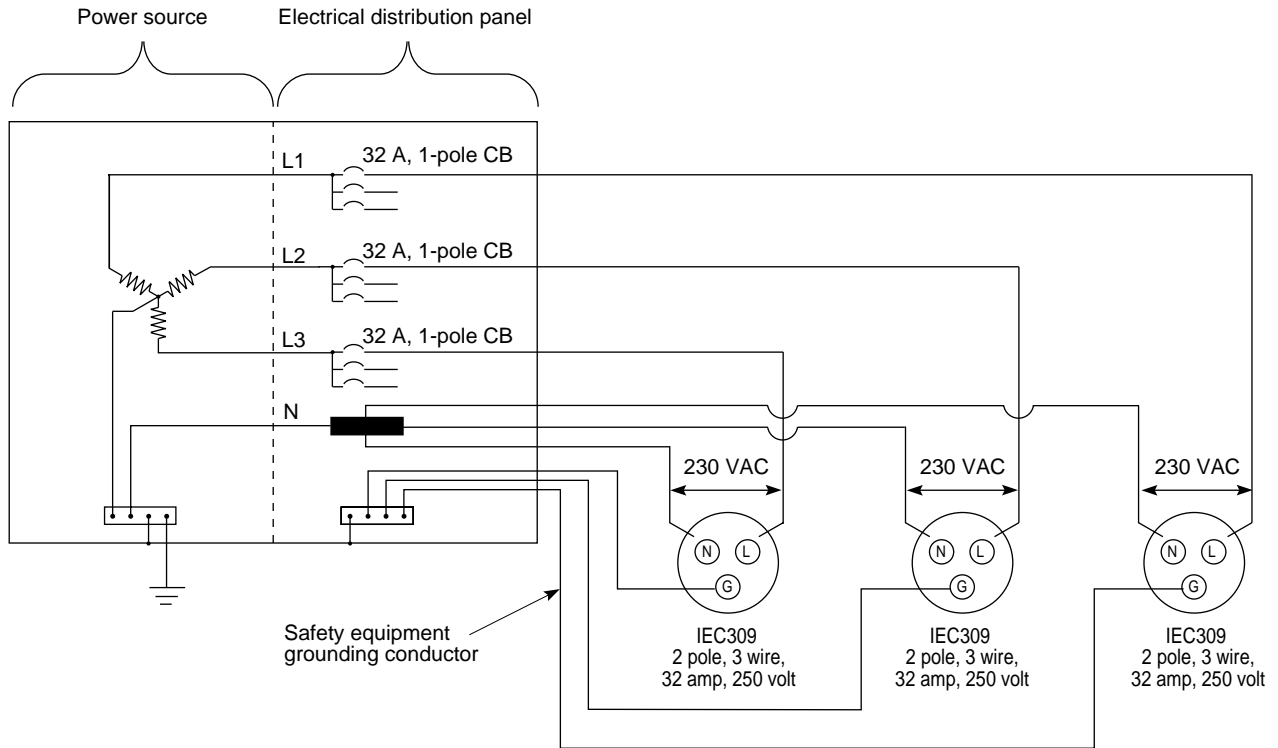

Figure B-9 Chassis Branch Circuit Diagram for 230 VAC, 32 amp, 3-wire, 1-phase (International)

Power Cables and Connectors

Table B-1 summarizes the power cables and connectors for each power configuration, Tables B-2 through B-14 describe the power cables, and Figures B-10 through B-22 show the approximate physical appearance of each standard cable.

Table B-1 Power Cable and Connector Specifications

Description (Cable Part Number)	Cable Connector, Chassis End	Cable Connector, Source End	Cable Type	Power Source (Wall Plug)
O2/Octane/Origin200/ Origin Vault				
U.S., Canada, and Japan (9350102)	IEC320-C13	NEMA 5-15P	UL/CSA	NEMA 5-15R
International (9350018)	IEC320-C13	CEE 7/7, 2-P, 3-W, 10A, 240V	HAR	CEE 7/7, 2-P, 3-W, 10A, 240V
SGI 2000-series/Onyx2 Desk 120 V				
U.S. and Canada (not Japan) (9350050 or 9350807)	IEC320-C19	NEMA 5-20P	UL/CSA	NEMA 5-20R
SGI 2000-series/Onyx2 Desk 208 V				
U.S., Canada, and Japan (9350051 or 9350814)	IEC320-C19	NEMA 6-20P	UL/CSA	NEMA 6-20R
International (9350049 or 9350809)	IEC320-C19	IEC309, 2-P, 3-W, 16 A, 250 V	HAR	IEC309, 2-P, 3-W, 16 A, 250 V
Onyx2 Graph. Ins. Mod. 208 V				
U.S., Canada, and Japan	Fixed cable	NEMA L6-30P	UL/CSA	NEMA L6-30R
International	Fixed cable	IEC309, 2-P, 3-W, 32 A, 250 V	HAR	IEC309, 2-P, 3-W, 32 A, 250 V
Rack Chassis				
U.S., Canada, and Japan (013-2075-001, 013-2080-001)	Fixed cable with PDU	NEMA L6-30P	UL/CSA	NEMA L6-30R
International (013-1911-001, 013-1911-001)	Fixed cable with PDU	IEC309, 2-P, 3-W, 32 A, 250 V	HAR	IEC309, 2-P, 3-W, 32 A, 250 V

O2, Octane, Origin200, Origin Vault, and Peripheral Power Cables

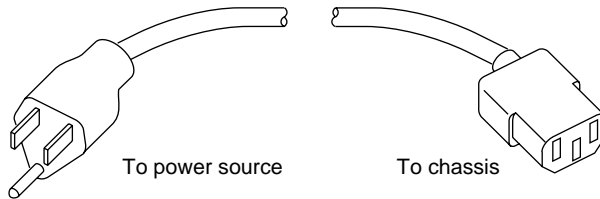

Figure B-10 O2, Octane, Origin200, Origin Vault, and Peripheral Power Cable, 125 VAC, 15 A (U.S., Canada, and Japan)

Table B-2 O2, Octane, Origin200, Origin Vault, and Peripheral Power Cable, 125 VAC, 15 A (U.S., Canada, and Japan)

Part Number	Description
9350102	Power cable, 125 VAC, 15 amp (U.S., Canada, and Japan) Round UL/CSA cable, 8.2' (2.5 m) length NEMA 5-15P plug at source end, IEC320-C13 receptacle at chassis end Used for O2, Octane, Origin200, Origin Vault, and peripherals See Figure B-10

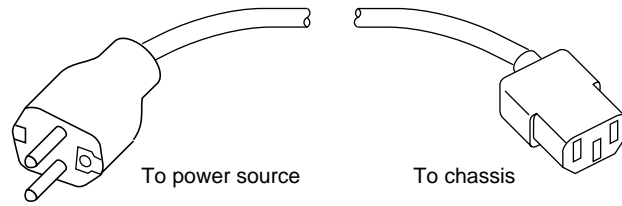

Figure B-11 O2, Octane, Origin200, Origin Vault, and Peripheral Power Cable, 250 VAC, 10 A (International)

Table B-3 O2, Octane, Origin200, Origin Vault, and Peripheral Power Cable, 250 VAC, 10 A (International)

Part Number	Description
9350018	Power cable, 250 VAC, 10 amp (International) Round HAR cable, 8.2' (2.5 m) length CEE 7/7 plug at source end, IEC320-C13 receptacle at chassis end Used for O2, Octane, Origin200, Origin Vault, and peripherals See Figure B-11

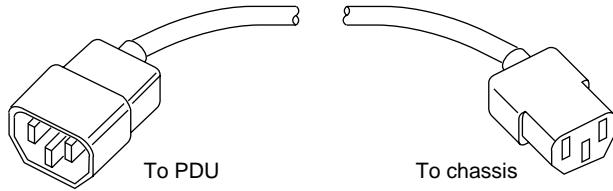

Figure B-12 Origin200 and Origin Vault Power Cable, 250 VAC, 15 A (For Rack PDU)

Table B-4 Origin200 and Origin Vault Power Cable, 250 VAC, 15 A (For Rack PDU)

Part Number	Description
9350818	Power cable, 250 VAC, 15 amp (for rack PDU) Round HAR cable, 3.25' (1 m) length IEC320-C13 plug at source end, IEC320-C13 receptacle at chassis end Used for MMSC, and for Origin200 and Origin Vault connected to a rack PDU See Figure B-12

SGI 2000-Series Deskside and Onyx2 Deskside Power Cables

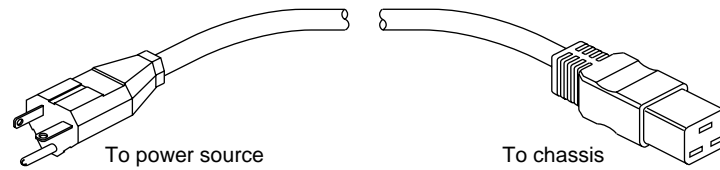

Figure B-13 SGI 2000-Series Deskside and Onyx2 Deskside Power Cable, 125 VAC, 20 A (U.S. and Canada)

Table B-5 SGI 2000-Series Deskside and Onyx2 Deskside Power Cable, 125 VAC, 20 A (U.S. and Canada)

Part Number	Description
9350050 or 9350807	Power cable, 125 VAC, 20 amp (U.S. and Canada) Round UL/CSA cable, 10' (3.05 m) length NEMA 5-20P plug at source end, IEC320-C19 receptacle at chassis end Used for SGI 2000-series deskside and Onyx2 deskside systems See Figure B-13

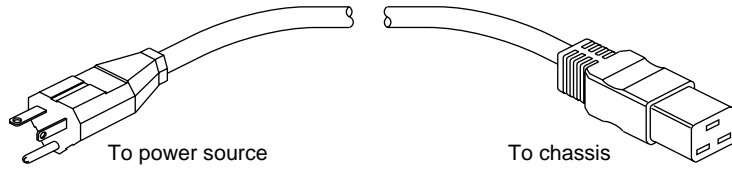

Figure B-14 SGI 2000-Series Deskside and Onyx2 Deskside Power Cable, 250 VAC, 20 A (U.S., Canada, and Japan)

Table B-6 SGI 2000-Series Deskside and Onyx2 Deskside Power Cable, 250 VAC, 20 A (U.S., Canada, and Japan)

Part Number	Description
9350051 or 9350814	Power cable, 250 VAC, 20 amp (U.S., Canada, and Japan) Round UL/CSA cable, 8.2' (2.5 m) length NEMA 6-20P plug at source end, IEC320-C19 receptacle at chassis end Used for SGI 2000-series deskside and Onyx2 deskside systems See Figure B-14

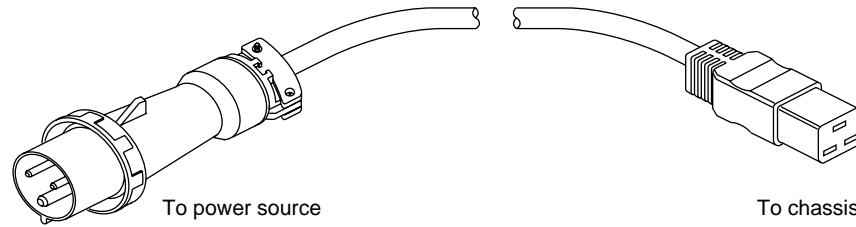

Figure B-15 SGI 2000-Series Deskside and Onyx2 Deskside Power Cable, 250 VAC, 16 A (International)

Table B-7 SGI 2000-Series Deskside and Onyx2 Deskside Power Cable, 250 VAC, 16 A (International)

Part Number	Description
9350049 or 9350809	Power cable, 250 VAC, 16 amp (International) Round HAR cable, 10' (3.05 m) length IEC309 16 amp plug at source end, IEC320-C19 receptacle at chassis end Used for SGI 2000-series deskside and Onyx2 deskside systems See Figure B-15

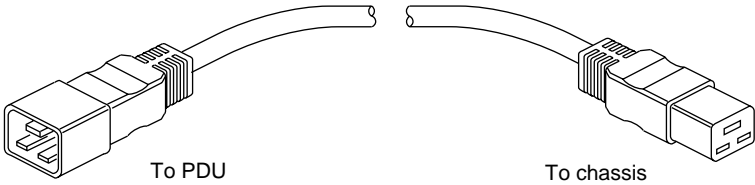

Figure B-16 SGI 2000-Series Base Module Power Cable, 250 VAC, 20 A (For Rack PDU)

Table B-8 SGI 2000-Series Base Module Power Cable, 250 VAC, 20 A (For Rack PDU)

Part Number	Description
9350816	Power cable, 250 VAC, 20 amp (for rack PDU) Round UL/CSA cable, 8.2' (2.5 m) length IEC320-C19 plug at source end, IEC320-C19 receptacle at chassis end Used for SGI 2000-series base modules connected to a rack PDU See Figure B-16

Onyx2 Graphics Insert Module Power Cables

This section shows the power cables used on the Silicon Graphics Onyx2 rack-mounted graphics insert module (GIM). These power cables are fixed into the chassis. Replacement should only be performed by a licensed electrician.

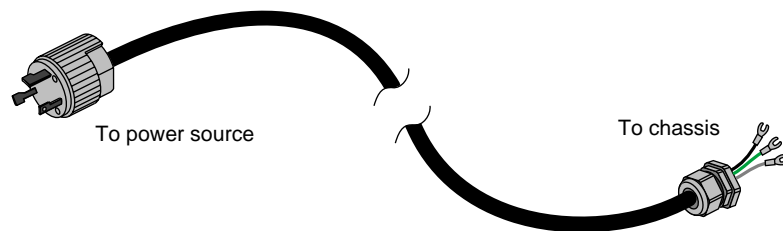

Figure B-17 Graphics Insert Module Power Cable, 250 VAC, 30 A (U.S., Canada, and Japan)

Table B-9 Graphics Insert Module Power Cable, 250 VAC, 30 A (U.S., Canada, and Japan)

Description

Power cable, 250 VAC, 30 amp (U.S., Canada, and Japan)
Round UL/CSA cable, 8' (2.4 m) length, 12 AWG
L6-30P plug at source end, #10 spring fork lugs fixed at chassis end
Used for Onyx2 Graphics Insert Module
See Figure B-17

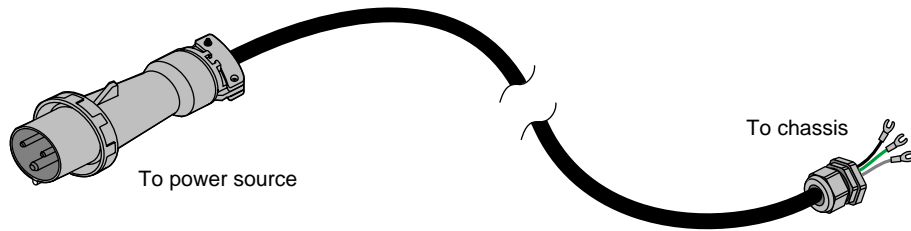

Figure B-18 Graphics Insert Module Power Cable, 250 VAC, 32 A (International)

Table B-10 Graphics Insert Module Power Cable, 250 VAC, 32 A (International)

Description

Power cable, 250 VAC, 32 amp (International)
Round HAR cable, 8' (2.4 m) length, 12 AWG
IEC309 32 amp plug at source end, #10 spring fork lugs fixed at chassis end
Used for Onyx2 Graphics Insert Module
See Figure B-18

SGI 2000-Series, Origin Peripherals, and Onyx2 Rack Power Distribution Units (PDUs)

This section shows the PDUs (power distribution units) used on the Origin200, Origin Vault, SGI 2000-series, and Onyx2 rack systems.

Note: Early version of the rack chassis came with a different style PDU. The older style PDUs are larger, and the power cords plug into them from the inside of the chassis rather than from the back of the chassis (as on the newer style PDUs). Only the newer style is shown in this book.

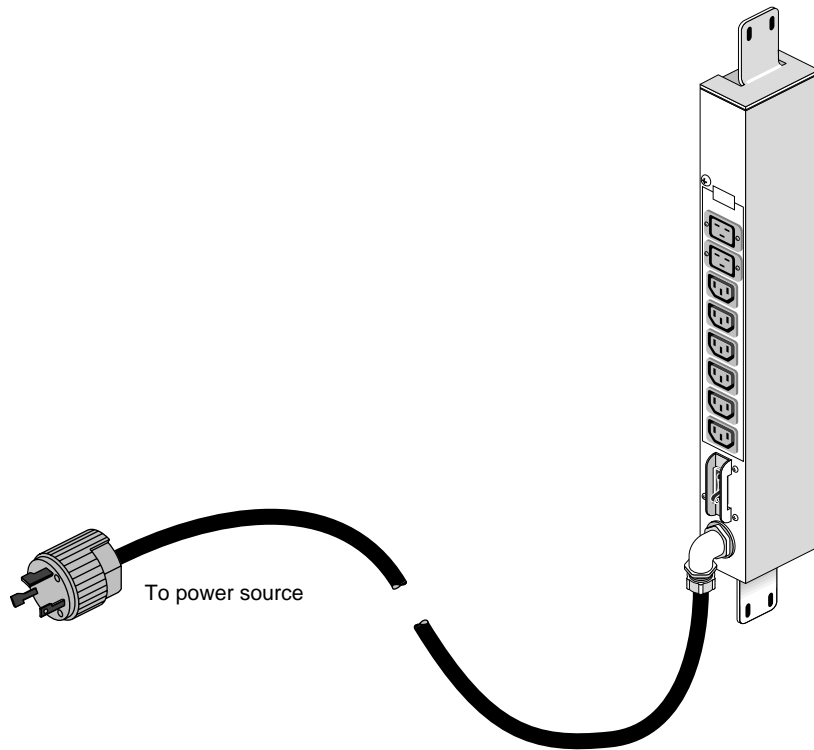

Figure B-19 SGI 2000-Series and Onyx2 Rack Power Cable, 250 VAC, 30 A (U.S., Canada, and Japan)

Table B-11 SGI 2000-Series and Onyx2 Rack Power Cable, 250 VAC, 30 A (U.S., Canada, and Japan)

Part Number	Description
013-2075-001	Power cable, 250 VAC, 30 amp (U.S., Canada, and Japan) Round UL/CSA cable, 10' (3.05 m) length NEMA L6-30P plug at source end, multiple-outlet PDU at chassis end PDU has two IEC320-C19, and six IEC320-C13 receptacles Used for SGI 2000-series and Onyx2 rack systems See Figure B-19

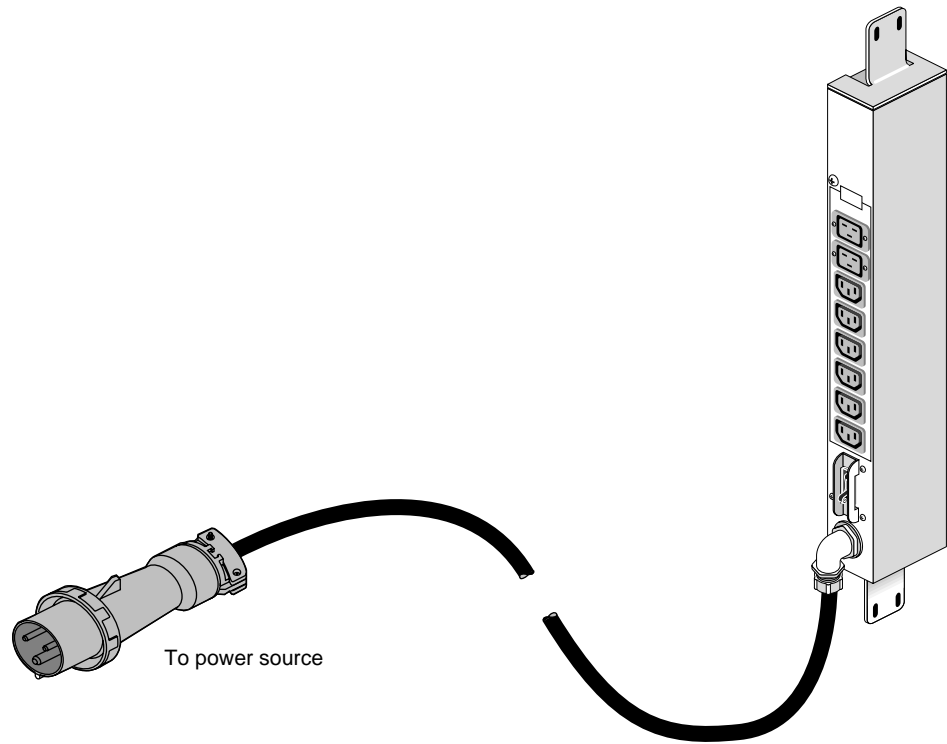

Figure B-20 SGI 2000-Series and Onyx2 Rack Power Cable, 250 VAC, 32 A (International)

Table B-12 SGI 2000-Series and Onyx2 Rack Power Cable, 250 VAC, 32 A (International)

Part Number	Description
013-1910-001	Power cable, 250 VAC, 32 amp (International) Round HAR cable, 10' (3.05 m) length IEC309 32 amp plug at source end, multiple-outlet PDU at chassis end PDU has two IEC320-C19, and six IEC320-C13 receptacles Used for SGI 2000-series and Onyx2 rack systems See Figure B-20

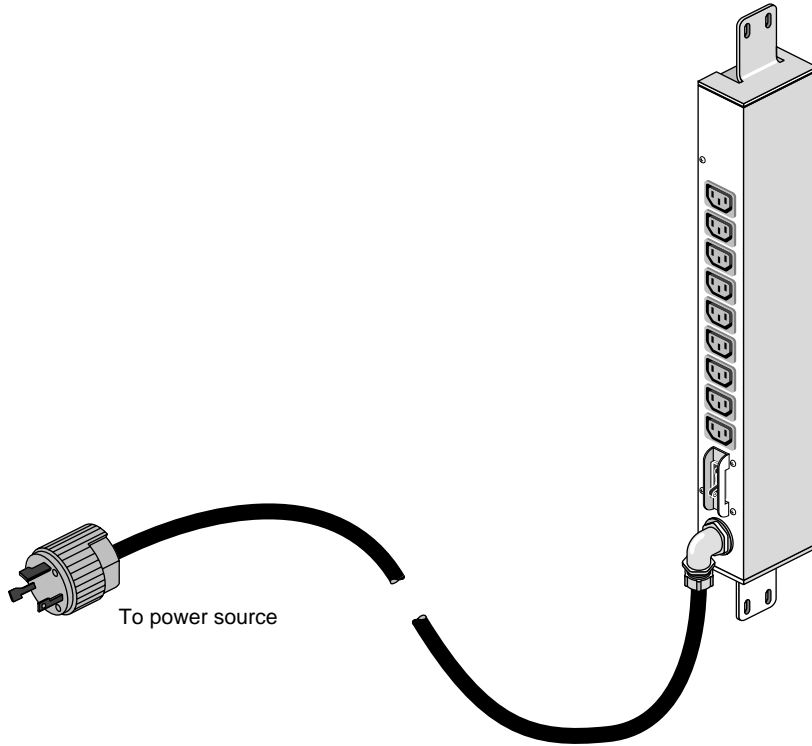

Figure B-21 Origin200 and Origin Vault Rack Power Cable, 250 VAC, 30 A (U.S., Canada, and Japan)

Table B-13 Origin200 and Origin Vault Rack Power Cable, 250 VAC, 30 A (U.S., Canada, and Japan)

Part Number	Description
013-2080-001	Power cable, 250 VAC, 30 amp (U.S., Canada, and Japan) Round UL/CSA cable, 10' (3.05 m) length NEMA L6-30P plug at source end, multiple-outlet PDU at chassis end PDU has nine IEC320-C13 receptacles Used for Origin200 and Origin Vault rack systems See Figure B-21

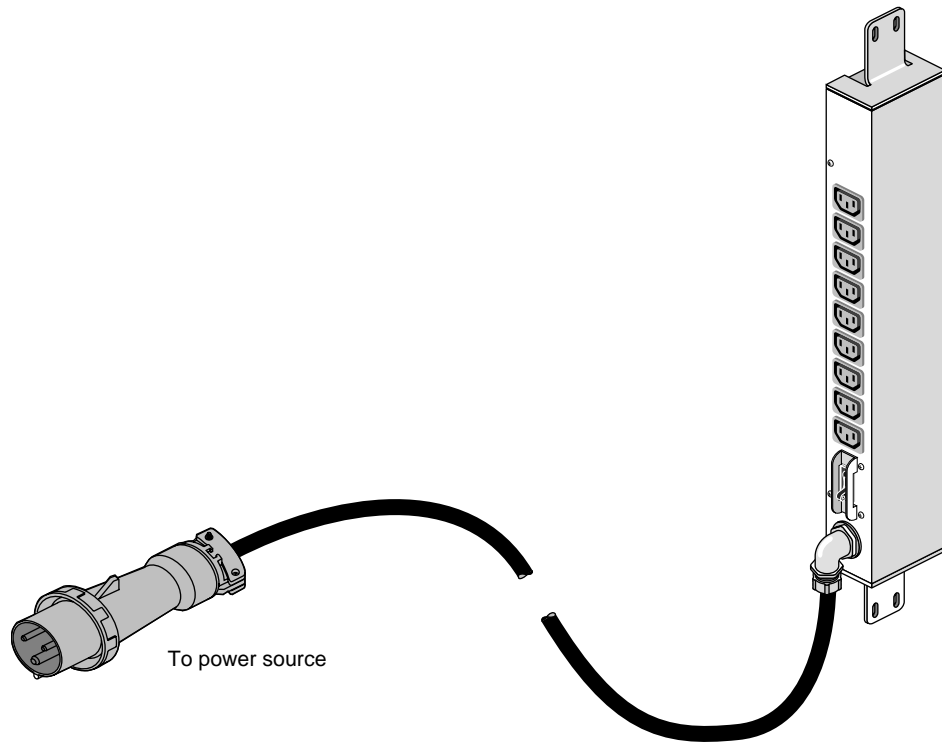

Figure B-22 Origin200 and Origin Vault Rack Power Cable, 250 VAC, 32 A (International)

Table B-14 Origin200 and Origin Vault Rack Power Cable, 250 VAC, 32 A (International)

Part Number	Description
013-1911-001	Power cable, 250 VAC, 32 amp (International) Round HAR cable, 10' (3.05 m) length IEC309 32 amp plug at source end, multiple-outlet PDU at chassis end PDU has nine IEC320-C13 receptacles Used for Origin200 and Origin Vault rack systems See Figure B-22

Safety and Protection Equipment

Depending on the location and size of an installation site, consider the following for safety and protection:

- Cable-management equipment
- An emergency power shutdown control
- Fire fighting equipment with an electrical rating
- Lightning protection
- Power-line treatment, such as an uninterruptible power supply (UPS).

Installing Cable-Management Equipment

Cable-management equipment protects people against electrical accidents and equipment against premature wear and accidental loss of power. The equipment includes cable routing guides and trays, walkway guards, and plug restraints.

Install cable-management equipment if:

- People require access to locations with power cables or connections
- Power cables could become disconnected
- Power cables pass across aisles or other paths.

Always isolate power cables from signal cables to minimize the transmission of noise from the power to the signal cables.



Warning: Check the cable-management equipment specifications for power cable limitations. Improperly installed cable-management equipment can cause unsafe working conditions.

Emergency Power-Off Switch

An emergency power-off (EPO) switch is a safety feature that protects people and equipment from these hazardous electrical situations:

- Personnel are exposed to or in contact with electrical sources
- Large installations have many components to power off quickly during emergencies
- Site is subject to power outages, drop-outs, and surges.

Install an emergency power-off switch at the main entries to the computer location. For large installations, place an additional switch within easy reach of the main administrator's station. The switch must be wired to the main circuit panel to disconnect power to all computer equipment at the location.



Warning: A licensed electrician should perform all wiring to ensure that the installation meets local and country electrical codes.

Fire-Fighting Equipment With an Electrical Rating

Check the site for adequate fire-fighting equipment for the new computer devices. Place an adequate number of small fire extinguishers (rated for electrical fires) at entrances, exits, and other obvious locations. Bear in mind that some fire-extinguishing equipment leaves no residue, while other equipment can destroy sensitive components and surfaces.

Note: While Halon fire-protection systems are ideal for suppressing fire without damaging computer equipment, Halon systems are being phased out because of their deleterious effects on the environment. If a site already uses Halon, check the national and local environmental codes and guidelines and plan accordingly.

For larger installations involving several system chassis, consider isolating all computers in one room and providing room-level fire protection.



Warning: Use licensed professionals to install extensive fire-protection systems. Room-level fire protection typically relies on gas evacuation within an enclosed area. In addition, adequate warnings, overrides, and training must be provided to ensure people's safety.

Lightning Protection

Install lightning protection at the site if:

- the site is in an electrical storm area
- the local utility company uses lightning protection on the primary power source
- overhead power lines provide the site's primary power.

Lightning protection also helps prevent damage at locations with large power surges, such as in some industrial settings and at locations with older or overburdened power grids.

Consult with a licensed professional or appropriate organization for assistance with lightning protection systems at the installation site.

Power-Line Treatment

Power-line treatment may be required if the site uses unreliable power, with problems such as fluctuating voltage, transients, surges and spikes, and noise. Common causes of unreliable power are old wiring, load-switching equipment (such as welding and plating devices), and variable-speed motors or motors that start and stop frequently.

A variety of devices are available to improve power-line quality, including:

- line conditioners
- line regulators
- isolation transformers
- uninterruptible power supplies (UPS) and standby power supplies (SPS).

Caution: When selecting a UPS or SPS, it is important to consider the inrush current of the systems to be powered. Failure to do so could result in equipment damage or even personal injury. See "Electrical Requirements" on page 13 and the power sections in chapters 3 through 8 for help in selecting a UPS or SPS.

The size of a UPS or SPS should take into account both the wattage and the VA rating of the systems it will power. Since many SGI systems are power-factor corrected, the watt and VA ratings may be very similar. However, not all systems are power-factor corrected. Additionally, basing the size of a UPS or SPS on the VA rating alone is not sufficient. In some cases a UPS may be rated to handle the VA loading of a particular system, but will not be able to handle the watt loading of the same system.

SGI strongly recommends that UPS or SPS power sources used with SGI systems produce a sine wave output. In no event should SGI systems be used with power sources producing a square wave output.

Consult a licensed professional or an appropriate organization for assistance with selecting and installing power-line treatment equipment.

Index

Numbers

- 100-volt power
 - Japan, 63, 67
- 13W3 connector, 109
- 220 volt chassis branch circuits
 - rack, 126

A

- acoustics, 22
- additional documentation, xix
- air conditioning, 17
 - failure, 19
 - terminology, 17
- airflow
 - O2, 29
 - Octane, 36
 - Onyx2 deskside, 59
 - Onyx2 Graphics Expansion Module, 73
 - Onyx2 rack, 85
 - Origin200, 45
 - Origin Vault, 45
 - SGI 2000-series deskside, 59
 - SGI 2000-series rack, 85
- amps, defined, 14
- antistatic packaging, 20
- ASCII terminal, 49, 57, 64, 113

B

- base modules, 55
- branch circuit grounding, 119
- Btu, defined, 17
- Btu/hr, defined, 17

C

- cable-management equipment, 145
- cable opening
 - Onyx2 rack, 90
 - SGI 2000-series rack, 90
- cable routing, 116
- cables
 - power, 129, 145
 - signal, 145
- cabling distance for monitors, 109
- cabling issues
 - O2, 32
 - Octane, 39
 - Onyx2 deskside, 69
 - Onyx2 Graphics Expansion Module, 77
 - Onyx2 rack, 108
 - Origin200, 50
 - Origin Peripherals rack, 104
 - Origin Vault, 53
 - SGI 2000-series deskside, 64
 - SGI 2000-series rack, 100

- carpeting
 - and acoustics, 22
 - and ESD, 20
- caster positions
 - Onyx2 deskside, 60
 - Onyx2 rack, 84
 - SGI 2000-series deskside, 60
 - SGI 2000-series rack, 84
- ceiling tiles, 22
- Celsius to Fahrenheit conversion, 25
- chassis branch circuits
 - deskside, 123
 - O2, Octane, Origin200, and Origin Vault, 121
- chassis-to-chassis grounding, 92
- checklist for site preparation, 3
- circuit breaker, 119
- circuit breakers, 16, 117
- clearances
 - Onyx2 deskside, 58
 - Onyx2 rack, 82
 - Origin200, 44
 - Origin Peripherals rack, 82
 - Origin Vault, 44
 - SGI 2000-series deskside, 58
 - SGI 2000-series rack, 82
- connectors, power, 129
- consultants, 2
- convenience outlets, 116
- coordinator, 2
- CrayLink, 15, 46, 50, 92, 96, 100, 104, 108, 115, 119, 126
 - defined, 79
- custom power cables, 116

D

- dB, 22
- DB13W3 connector, 109
- dBa, 22
- delivery route, 10
- differential SCSI, 113
- distribution panel, 119
- doorways, 10
- drapes
 - and acoustics, 22

E

- earthing, branch circuit, 119
- earthing straps
 - Onyx2 racks, 92
 - SGI 2000-series racks, 92
- earthing wrist strap, 20
- electrical codes, 115
- electrical distribution panel, 119
- electrical fires, 146
- electrical issues, 13
- electrical storms, 147
- electromagnetic interference, 109
 - defined, 20
- electrostatic discharge, defined, 20
- elevators, 10
- emergency power shutdown control, 146
- ergonomics, 22
- external peripherals
 - O2, 32
 - Octane, 39
 - Onyx2 deskside, 68
 - Onyx2 Graphics Expansion Module, 76
 - Onyx2 rack, 108
 - Origin200, 49

- Origin Peripherals rack, 104
- SGI 2000-series deskside, 64
- SGI 2000-series rack, 100

external SCSI devices, 112

F

- Fahrenheit to Celsius conversion, 25
- feet, Origin200 and Origin Vault, 42
- fire extinguishers, 146
- fire fighting equipment, 146
- flat reflective surfaces, 22
- floor loading
 - Onyx2 rack, 84
 - SGI 2000-series rack, 84
- fluctuating voltage, 147

G

- gas evacuation, 146
- graphics expansion module (GEM), 71
- grounding, branch circuit, 119
- grounding straps
 - Onyx2 racks, 92
 - SGI 2000-series racks, 92
- grounding wrist strap, 20
- ground potential, 119

H

- hallways, 10
- Halon, 146
- harmonic factor, 16
- heat output, in general, 17

- humidity, 21
- humidity gradient, 21

I

- input filter capacitors, 15
- input impedance, 15
- inrush current, defined, 15
- isolation transformers, 147

J

- Japan
 - and 100-volt power, 63, 67

K

- keyboards, 112

L

- laptop computer, using as terminal, 113
- leveling feet, 11
- licensed electrician, 115
- lightning protection, 147
- line conditioners, 147
- line regulators, 147
- local regulations, 23

M

- main circuit, 117
- metric measure, 24
- mice, 112

- mission-critical installations, 19
- monitors
 - cabling distance, 109
 - physical characteristics, 110
- motors, 116
- multiple Onyx2 racks
 - selecting a location, 92
- multiple Origin Peripherals racks
 - selecting a location, 92
- multiple SGI 2000-series racks
 - selecting a location, 92

N

- noise-generating equipment, 116
- noise levels, 22

O

- O2, 27
 - airflow, 29
 - cabling issues, 32
 - external peripherals, 32
 - physical characteristics, 30
 - power and cooling, 31
 - selecting a location, 28
- Octane, 33
 - airflow, 36
 - cabling issues, 39
 - external peripherals, 39
 - physical characteristics, 37
 - power and cooling, 38
 - selecting a location, 34
- Onyx2 deskside
 - airflow, 59
 - cabling issues, 69
 - caster positions, 60
 - clearances, 58

- external peripherals, 68
 - physical characteristics, 65
 - power and cooling, 66
 - selecting a location, 57
 - voltage requirements, 66
- Onyx2 Graphics Expansion Module, 71
 - airflow, 73
 - cabling issues, 77
 - external peripherals, 76
 - physical characteristics, 74
 - power and cooling, 75
 - power cable, 96
 - selecting a location, 72
- Onyx2 rack
 - airflow, 85
 - cable opening, 90
 - cabling issues, 108
 - caster positions, 84
 - clearances, 82
 - external peripherals, 108
 - floor loading, 84
 - grounding straps, 92
 - PDU (power distribution unit), 96
 - physical characteristics, 105
 - power and cooling, 106
 - selecting a location, 81
- operating temperature, 17
- Origin200, 41
 - airflow, 45
 - cabling issues, 50
 - external peripherals, 49
 - feet, 42
 - physical characteristics, 47
 - power and cooling, 48
 - selecting a location, 42
- Origin2000, xvii
- Origin200 rack, PDU (power distribution unit), 96
- Origin Peripherals rack
 - cabling issues, 104
 - clearances, 82

- external peripherals, 104
- physical characteristics, 101
- power and cooling, 102
- selecting a location, 81

Origin Vault, 41, 112

- cabling issues, 53
- feet, 42
- physical characteristics, 51
- power and cooling, 52
- SCSI cables, 53
- selecting a location, 42

Origin Vault rack, PDU (power distribution unit), 96

overhead power lines, 147

P

PDU (power distribution unit)

- Onyx2 rack, 96
- Origin200 rack, 96
- Origin Vault rack, 96
- SGI 2000-series rack, 96

peak current, 15

peak inrush current, 16

phase balancing, 119

physical characteristics

- monitors, 110
- O2, 30
- Octane, 37
- Onyx2 deskside, 65
- Onyx2 Graphics Expansion Module, 74
- Onyx2 rack, 105
- Origin200, 47
- Origin Peripherals rack, 101
- Origin Vault, 51
- SGI 2000-series deskside, 61
- SGI 2000-series rack, 97

power and cooling

- O2, 31
- Octane, 38

- Onyx2 deskside, 66
- Onyx2 Graphics Expansion Module, 75
- Onyx2 rack, 106
- Origin200, 48
- Origin Peripherals rack, 102
- Origin Vault, 52
- SGI 2000-series deskside, 62
- SGI 2000-series rack, 98

power cables, 129, 145

power-company lines, 16

power connectors, 129

power factor, 14

power factor, defined, 15

power-factor correction, 15, 148

power-line treatment, 147

protection equipment, 145

PS/2 keyboards, 112

PS/2 mice, 112

R

raised floors, 11

room-level fire protection, 146

S

safety equipment, 145

SCSI

- differential, 113
- single-ended, 113

SCSI devices, 112

selecting a location

- multiple Onyx2 racks, 92
- multiple Origin Peripherals racks, 92
- multiple SGI 2000-series racks, 92
- O2, 28
- Octane, 34

- Onyx2 deskside, 57
- Onyx2 Graphics Expansion Module, 72
- Onyx2 rack, 81
- Origin200, 42
- Origin Peripherals rack, 81
- Origin Vault, 42
- SGI 2000-series deskside, 57
- SGI 2000-series rack, 81
- serial ASCII terminal, 49, 57, 64, 113
- serial cable, 113
- serial connectors, 113
- serial switchbox, 113
- SGI 2000-series
 - defined, xvii
- SGI 2000-series deskside
 - airflow, 59
 - cablings issues, 64
 - caster positions, 60
 - clearances, 58
 - external peripherals, 64
 - physical characteristics, 61
 - power and cooling, 62
 - selecting a location, 57
 - voltage requirements, 62
- SGI 2000-series rack
 - airflow, 85
 - cable opening, 90
 - cablings issues, 100
 - caster positions, 84
 - clearances, 82
 - external peripherals, 100
 - floor loading, 84
 - grounding straps, 92
 - PDU (power distribution unit), 96
 - physical characteristics, 97
 - power and cooling, 98
 - selecting a location, 81
- SGI 2100, xvii
- SGI 2200, xvii

- SGI 2400, xvii
- SGI 2800, xvii
- signal cables, 145
- sine wave, 148
- single-ended SCSI, 113
- site personnel, xvii
- site preparation, overview, 2
- sound baffles, 22
- spikes, 147
- SPS (standby power supply), 15, 16, 147
- square wave, 148
- SSE, xvii, 92
- standby power supply (SPS), 15, 16, 147
- static electricity, 20
- superwide monitor, 111
- surges, 147
- system support engineers, xvii

T

- Technical Publications Library, xix
- THD (total harmonic distortion), defined, 16
- thermal gradient, 19
- thermal issues, 17
- thermal load, calculating, 18
- three phase power, 119
- tons of air conditioning, defined, 17
- tools, useful, 6
- total harmonic distortion (THD), defined, 16
- transformer, 119
- transients, 147

U

- uninterruptible power supply (UPS), 15, 16, 147

unreliable power, 147
UPS (uninterruptible power supply), 15, 16, 147
U.S. customary measure, 24

V

VA (volt-amps), 14, 148
vibration, 21
video monitors, 109
voltage requirements, 13
 Onyx2 deskside, 66
 SGI 2000-series deskside, 62
volts, defined, 14

W

wall coverings, and acoustics, 22
watts, defined, 14
wrist strap, 20

X

XTown, 15, 46, 50, 92, 96, 115, 119, 126

