

# Onyx2™ Rackmount Owner's Guide

Document Number 007-3457-003

## CONTRIBUTORS

Written by Mark Schwenden, Pablo Rozal, and Bruce Miles

Illustrated by Dan Young and Cheri Brown

Production by Linda Rae Sande

Engineering contributions by Bob Patel, Reuel Nash, Dan Farmer, Bob Murphy, Sam Sengupta, Mike Mackovitch, Mohsen Hosseini, Jeff Milo, Patrick Conway, Kirk Law, Suzanne Jones, and Bob Marinelli.

St Peter's Basilica image courtesy of ENEL SpA and InfoByte SpA. Disk Thrower image courtesy of Xavier Berenguer, Animatica.

© 1997, Silicon Graphics, Inc.— All Rights Reserved

The contents of this document may not be copied or duplicated in any form, in whole or in part, without the prior written permission of Silicon Graphics, Inc.

## RESTRICTED RIGHTS LEGEND

Use, duplication, or disclosure of the technical data contained in this document by the Government is subject to restrictions as set forth in subdivision (c) (1) (ii) of the Rights in Technical Data and Computer Software clause at DFARS 52.227-7013 and/or in similar or successor clauses in the FAR, or in the DOD or NASA FAR Supplement. Unpublished rights reserved under the Copyright Laws of the United States. Contractor/manufacturer is Silicon Graphics, Inc., 2011 N. Shoreline Blvd., Mountain View, CA 94043-1389.

## Shielded Cables

This product requires the use of external shielded cables in order to maintain compliance with Part 15 of the FCC rules.

## FCC Warning

This equipment has been tested and found compliant with the limits for a Class A digital device, pursuant to Part 15 of the FCC rules. These limits are designed to provide reasonable protection against harmful interference when the equipment is operated in a commercial environment. This equipment generates, uses, and can radiate radio frequency energy and if not installed and used in accordance with the instruction manual, may cause harmful interference to radio communications. This product requires the use of external shielded cables in order to maintain compliance. Changes or modification to this product not expressly approved by the party responsible for compliance could void the user's authority to operate the equipment. Operation of this equipment in a residential area is likely to cause harmful

interference, in which case users will be required to correct the interference at their own expense.

You may find the following booklet, prepared by the Federal Communications Commission, helpful: *Interference Handbook 1993 Edition*. This booklet is available from the U.S. Government Printing Office, Superintendent of Documents, Mail Stop: SSOP, Washington D.C. 20402-9328, ISBN 0-16-041736-8.

#### Canadian Department of Communications Statement

This digital apparatus does not exceed the Class A limits for radio noise emissions from digital apparatus as set out in the Radio Interference Regulations of the Canadian Department of Communications.

#### Attention

Le présent appareil numérique n'émet pas de perturbations radioélectriques dépassant les normes applicables aux appareils numériques de Classe A prescrites dans le Règlement sur les interférences radioélectriques établi par le Ministère des Communications du Canada.

#### Manufacturer's Regulatory Declarations

This workstation conforms to several national and international specifications and European directives as listed on the "Manufacturer's Declaration of Conformity," which is included with each computer system and peripheral. The CE insignia displayed on each device is an indication of conformity to the European requirements.

Your workstation has several governmental and third-party approvals, licenses, and permits. Do not modify this product in any way that is not expressly approved by Silicon Graphics, Inc. If you do, you may lose these approvals and your governmental agency authority to operate this device.

#### Canadian and European Compliance Insignia



## VCCI Class 1 Statement for Japan

この装置は、第一種情報装置（商工業地域において使用されるべき情報装置）で商工業地域での電波障害防止を目的とした情報処理装置等電波障害自主規制協議会（VCCI）基準に適合しております。

従って、住宅地域またはその隣接した地域で使用すると、ラジオ、テレビジョン受信機等に受信障害を与えることがあります。

取扱説明書に従って正しい取り扱いをして下さい。

Silicon Graphics and the Silicon Graphics logo, IRIS, and Onyx are registered trademarks of Silicon Graphics, Inc. and InfiniteReality, IRIX, Origin Vault, Onyx2, Onyx2 Reality, RealityMonster, and S2MP are trademarks of Silicon Graphics, Inc. SILICON SURF is a service mark of Silicon Graphics, Inc. CrayLink is a trademark of Cray Research, Inc. R10000 is a trademark of MIPS Technologies, Inc. ADAT is a registered trademark of Alesis Corporation. EXABYTE is a trademark of EXABYTE Corporation. StereoView is a trademark of StereoGraphic Corporation. UNIX is a registered trademark in the United States and other countries, licensed exclusively through X/Open Company, Ltd.

---

# Contents

**List of Figures** xi

**List of Tables** xv

**About This Guide** xvii

Finding Additional Information xix

    Online Reference (Manual) Pages xxi

    Release Notes xxi

    World Wide Web-Accessible Documentation xxii

Conventions xxii

1. **Introducing the Onyx2 Rackmount System** 1
  - Rackmount System Features and Options 1
    - Graphics Features 1
    - Additional System Features 2
  - Hardware Overview 2
    - The Single Rack Graphics System 3
    - The Multirack Onyx2 6
    - Graphics Subsystem Overview 13
    - Computing Subsystem Overview 13
    - Graphics BaseIO Subsystem 14
  - Onyx2 Graphics Rack Functional Overview 15
    - Linked Microprocessors 15
    - Multirack Interconnect Features 16
    - S2MP Architecture and Memory 17
    - The Node Boards 17
    - XIO Boards 19

- Compute Module Midplane 19
- Graphics Module Midplane 19
- System Location and Environment 22
- 2. Chassis Tour 25**
  - Graphics Rack Chassis 25
  - Graphics Module Components 31
  - Compute Module Components 33
    - Board Configurations 33
    - XIO Boards 36
    - BaseIO Panel 37
  - Node Boards 40
    - The R10000 Processor 42
    - Main Memory 42
    - HUB ASIC 42
    - The Node Board Status LEDs 42
  - Graphics Rack System Controllers 44
    - Module System Controller and Display 44
    - Multimodule Controller and Display 44
  - Router Boards 45
    - Null Router Board 46
    - Star Router Board 47
    - Rack Router 47
    - Module-to-Module Interconnects 47
      - Cautionary Guidelines 48
  - Optional PCI Board Carrier 48
- 3. System Configurations, Connections, and Cabling 51**
  - Rackmount Configurations 51
  - Graphics Interface Panels 56
    - DG5 Board Operation 59
    - Connectors on the DG5 Option Board 60
    - Connectors on the Optional GVO Daughterboard 61
    - Cabling Options 63

	The Graphics BaseIO Interface Panel	66
	10/100 BaseT Ethernet Port	67
	Parallel Port Connector	69
	Mouse and Keyboard Ports	72
	Analog Stereo In and Out (RCA-Type) Ports	75
	Serial Connectors	77
	Optical Digital Audio Interface Connectors	80
	Loopthrough and Digital Audio Connectors	82
	Standard SCSI Connector	84
	Speaker and Microphone Connections	87
<b>4.</b>	<b>Getting Started</b>	<b>91</b>
	Using Your Monitor	92
	Connecting a 24-Inch Monitor	92
	Keyboard and Mouse Connections	93
	SCSI Requirements and Configurations	94
	Connecting Your System to an Ethernet	95
	System Power-On Procedures	95
	Booting Your System	102
	Installing the Operating System	104
	Powering Off the System	105
<b>5.</b>	<b>Installing and Replacing Customer-Replaceable Units</b>	<b>107</b>
	General Safety Information	109
	Before Replacing Any Components	109
	Opening the Cable Cover Door	109
	Opening and Closing the Compute Module Drive Door	111
	CRU Remove and Replace Procedures	112
	Removing a Drive Module	112
	Removing a Module's Facade	115
	Removing the MSC and CD-ROM	118

- 6. **Using the System Controllers** 121
  - The MMSC 121
  - The MSC 123
  - Understanding the Controller's LEDs and Switches 127
    - Controller Features and Functions 128
    - MSC Status Messages 130
- 7. **Basic Troubleshooting** 133
  - General Guidelines 133
  - Operating Guidelines 134
  - Module Power Supply Problems 135
    - Amber (Yellow) LED 136
    - Green LED 136
    - Red LED 136
  - Crash Recovery 137
    - Rebooting the System 137
    - Restoring System Software 137
    - Restoring from Backup Tapes 138
    - Restoring a Filesystem From the System Maintenance Menu 138
- A. **System Specifications** 145
- B. **Drive Maintenance** 147
  - Cleaning the 4-mm DAT and 8-mm Tape Drives 147
  - 4-mm DAT Drive 148
    - Loading and Unloading Cassettes 148
    - Removing a Jammed 4-mm Cassette 148
    - Cleaning the 4-mm DAT Drive 149
    - Front Panel Lights 149
  - Care and Cleaning of the Exabyte 8-mm Tape Drive 150
    - Front Panel Lights 150
    - Removing a Jammed 8-mm Tape Cartridge 151



	CD-ROM Care and Maintenance	152
	CD-ROM Environmental Considerations	153
	CD-ROM Front Panel Operational Features	154
	Quarter-Inch Cartridge Tape Drive Preventive Maintenance	155
<b>C.</b>	<b>Module System Controller Messages</b>	157
<b>D.</b>	<b>Video Format Combiner Tutorial</b>	159
	Reinitializing Graphics	159
	Modifying Video Formats	161
	Performing Steps to Avoid a Reboot	161
	Selecting a Video Format for Channel 0	163
	Selecting a Video Format for Channel 1	164
	Saving Video Format Combinations to the GE Board's EEPROM	166
	Resizing a Single-Channel Combination	172
	Using Ircombine With GVO	175
	Defining a Video Format Combination using GVO	175
	Redisplaying Graphics	177
	Combiner Interface Summary	178
	<b>Index</b>	179



---

## List of Figures

<b>Figure i</b>	Rackmount System Owner's Guide	xix
<b>Figure ii</b>	Information Sources for the Onyx2 Rackmount System	xx
<b>Figure 1-1</b>	Onyx2 Rackmount Graphics System	4
<b>Figure 1-2</b>	Single Rack Graphics Block Diagram Example	5
<b>Figure 1-3</b>	Onyx2 Multirack Graphics System Configuration	7
<b>Figure 1-4</b>	Multirack Three-Pipe Diagram Example	8
<b>Figure 1-5</b>	Multirack Four-Pipe Diagram Example	9
<b>Figure 1-6</b>	RealityMonster Multirack Graphics System Configuration	10
<b>Figure 1-7</b>	RealityMonster Multirack 16P/8-Pipe Diagram Example	11
<b>Figure 1-8</b>	RealityMonster Multirack 16P/8-Pipe Configuration Example	12
<b>Figure 1-9</b>	Node Board Example	18
<b>Figure 1-10</b>	Processor Compute Module Midplane	20
<b>Figure 1-11</b>	Graphics Module Midplane	21
<b>Figure 2-1</b>	Onyx2 Rackmount System	26
<b>Figure 2-2</b>	Onyx2 Rack System (Rear View)	29
<b>Figure 2-3</b>	Graphics Module Pipes Diagram	31
<b>Figure 2-4</b>	Graphics Pipes in the Module	32
<b>Figure 2-5</b>	Block Diagram for the Compute Module (Single Rack)	34
<b>Figure 2-6</b>	Block Diagram for the Compute Modules (Multirack System)	35
<b>Figure 2-7</b>	Graphics BaseIO Panel (IO6G)	38
<b>Figure 2-8</b>	Node Board Positions in the Chassis	41
<b>Figure 2-9</b>	Node Board LEDs	43
<b>Figure 2-10</b>	MMSC Interface and Display Panel	45
<b>Figure 2-11</b>	Types of Router Boards	46
<b>Figure 2-12</b>	Crosstown and CrayLink Interconnect Cables	47
<b>Figure 2-13</b>	Optional PCI Board Carrier Assembly	49
<b>Figure 3-1</b>	Onyx2 Single-Rack System (8P and 2 Graphics Pipes)	52

<b>Figure 3-2</b>	Onyx2 Multirack System (16P and 4 Graphics Pipes)	53
<b>Figure 3-3</b>	Onyx2 Multirack System (24P and 2 Graphics Pipes)	54
<b>Figure 3-4</b>	Onyx2 RealityMonster Multirack System (16P and 8 Graphics Pipes)	55
<b>Figure 3-5</b>	DG5-8 Board Locations	57
<b>Figure 3-6</b>	DG5-2 Graphics Panel Connections (Without Options)	58
<b>Figure 3-7</b>	DG5-8 Board With Optional VIO5H	60
<b>Figure 3-8</b>	DG5/VIO5H 13W3 Connector Pinout	61
<b>Figure 3-9</b>	DG5 With Optional GVO Connectors	62
<b>Figure 3-10</b>	SuperWide Monitor	63
<b>Figure 3-11</b>	13W3 Monitor Cable and Adapters	64
<b>Figure 3-12</b>	Cable to Monitor Connection Example	65
<b>Figure 3-13</b>	BaseIO (IO6G) Assembly and Connectors	66
<b>Figure 3-14</b>	10/100 Base-T Ethernet Connector	68
<b>Figure 3-15</b>	Parallel Printer Port Location	70
<b>Figure 3-16</b>	Keyboard and Mouse Locations and Pinouts	73
<b>Figure 3-17</b>	Line In and Out Stereo Ports	76
<b>Figure 3-18</b>	RS-232/RS-422 Serial Connectors	78
<b>Figure 3-19</b>	Serial Port Connection Example	79
<b>Figure 3-20</b>	Optical Digital Audio Interface	81
<b>Figure 3-21</b>	Loopthrough and Digital Audio Connectors	83
<b>Figure 3-22</b>	68-Pin Single-Ended SCSI Connector	86
<b>Figure 3-23</b>	Cable Connection Locations on the Speakers	87
<b>Figure 3-24</b>	Speaker and Microphone Connections to the BaseIO	88
<b>Figure 4-1</b>	24-Inch SuperWide Monitor	93
<b>Figure 4-2</b>	Connecting a Graphics Module Power Cable	96
<b>Figure 4-3</b>	MSC Key Positions	97
<b>Figure 4-4</b>	Connecting the PDU Power Cable	98
<b>Figure 4-5</b>	Turning On the PDU	100
<b>Figure 4-6</b>	Powering On a Processor Compute Module	101
<b>Figure 4-7</b>	MMSC Power Up Selection	102
<b>Figure 4-8</b>	MMSC Interface	103
<b>Figure 4-9</b>	MMSC Interface	106
<b>Figure 5-1</b>	Onyx2 Rackmount Customer-Replaceable Units	108

---

<b>Figure 5-2</b>	Opening the Cable Cover Door	110
<b>Figure 5-3</b>	Opening the Compute Module's Door	111
<b>Figure 5-4</b>	Opening the SCA Disk Drive Units	113
<b>Figure 5-5</b>	Removing the Drive	114
<b>Figure 5-6</b>	Removing the Compute Module's Facade	116
<b>Figure 5-7</b>	Removing a Graphics Module Facade	117
<b>Figure 5-8</b>	Removing the MSC and CD-ROM	119
<b>Figure 6-1</b>	MMSC Display and Controls	121
<b>Figure 6-2</b>	MMSC Interface	122
<b>Figure 6-3</b>	MSC Status Panel and Switches	124
<b>Figure 6-4</b>	MSC Rear Serial Connector	126
<b>Figure B-1</b>	8-mm Tape Drive Front Panel	150
<b>Figure B-2</b>	Handling a Compact Disc	153
<b>Figure B-3</b>	CD-ROM Drive LED Status Indicators	154
<b>Figure B-4</b>	Tape Head Cleaning	156
<b>Figure D-1</b>	Combiner Main Window	160
<b>Figure D-2</b>	Combiner Main Window With Channels Selected	162
<b>Figure D-3</b>	Selecting a Channel Format	163
<b>Figure D-4</b>	Channel Attributes Window	165
<b>Figure D-5</b>	Combination Attributes Window	167
<b>Figure D-6</b>	Textport Error Message on the Main Window	168
<b>Figure D-7</b>	Combiner Main Window With Overlapping Channels	170
<b>Figure D-8</b>	Saving to Hardware Dialog Box	171
<b>Figure D-9</b>	Exit Warning Dialog Box	171
<b>Figure D-10</b>	Static Resize Selection	173
<b>Figure D-11</b>	Save a Combination	174
<b>Figure D-12</b>	GVO Attributes Window	176



---

## List of Tables

<b>Table 1-1</b>	Rack System Physical Specifications	22
<b>Table 2-1</b>	Major Components on the Front of the Graphics Rack	27
<b>Table 2-2</b>	Onyx2 Graphics Rack Rear Components	30
<b>Table 2-3</b>	Graphics Rack BaseIO Panel Connectors	39
<b>Table 3-1</b>	DG5 Configurations	56
<b>Table 3-2</b>	DG5-8/VIO5H Connectors	59
<b>Table 3-3</b>	Ethernet 10/100 Base-T Ethernet Port Pin Assignments	69
<b>Table 3-4</b>	Pinouts for the 36-Pin Parallel Port Connector	71
<b>Table 3-5</b>	Keyboard Port (6-Pin MINIDIN) Pin Assignments	74
<b>Table 3-6</b>	Mouse Port (6-Pin MINIDIN) Pin Assignments	74
<b>Table 3-7</b>	Analog Composite Video Port Pin Assignments	75
<b>Table 3-8</b>	68-Pin Single-Ended, High-Density SCSI Pinouts	84
<b>Table 6-1</b>	MSC Messages	130
<b>Table A-1</b>	Physical and Environmental Specifications	145
<b>Table A-2</b>	Electrical and Cooling Specifications	146
<b>Table B-1</b>	4-mm DAT Front Panel LED Status Indicators	149
<b>Table B-2</b>	LED States and Interpretations	151
<b>Table C-1</b>	MSC Alpha-Numeric Display Messages	157





---

## About This Guide

This guide is designed to help you understand, learn to use, manage, and troubleshoot your Onyx2™ rackmount graphics system. This document is organized as follows:

- Chapter 1 “Introducing the Onyx2 Rackmount System” describes the system and its capabilities and contrasts them with other graphics technology. A brief overview of the workstation’s compute and interface capabilities is provided.
- Chapter 2 “Chassis Tour” describes all of the system components and reviews all of the controls, indicators, and connectors.
- Chapter 3 “System Configurations, Connections, and Cabling” reviews hardware-specific configurations and connections. This chapter expands the information presented in the chassis tour to cover the optional expansion potential of the hardware. Connection of video, audio, Ethernet, serial, and fiber-based interfaces is discussed.
- Chapter 4 “Getting Started” covers the use of the graphics monitors. Power-up and power-down procedures are documented. Basic information on SCSI applications and IRIX operating system requirements is provided.
- Chapter 5 “Installing and Replacing Customer-Replaceable Units” describes installation and replacement procedures for the CD-ROM drive, System Controller, system disk, and data disks.
- Chapter 6 “Using the System Controllers” describes the multimodule System Controller and its interface panel. The module level System Controller sections cover controller uses and status messages.
- Chapter 7 “Basic Troubleshooting” offers information on tracking down and fixing simple hardware-related problems, checking the module power supplies, and using system recovery methods.
- Appendix A “Hardware Specifications” lists system specifications.
- Appendix B “Maintaining Drives” lists care and maintenance procedures for removable media drives.

- Appendix C “Module System Controller Messages” lists all the possible messages that can appear in the module System Controller’s display.
- Appendix D “Video Format Combiner Tutorial” consists of example exercises designed to demonstrate tasks you can perform using the video combiner utility with your InfiniteReality graphics system.

Start at the beginning to familiarize yourself with the features of your new system, or proceed directly to the information you need using the table of contents as your guide.

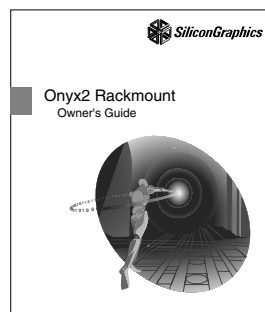
Software-specific information is found in the following software guides:

- *Personal System Administration Guide*
- *IRIX Admin: System Configuration and Operation*
- *IRIX Admin: Software Installation and Licensing*

## Finding Additional Information

The *Onyx2 Rackmount Owner's Guide* covers many basic and useful topics that are related to setting up, operating, and maintaining your rackmount graphics workstation. The following sections and illustrations describe multiple sources of information that you may find helpful or vital to your work with the Onyx2 rackmount.

Read the *Onyx2 Rackmount Owner's Guide* (this book) whenever you need help with the basic hardware aspects of your system, see Figure i. The system and the procedures in this guide are designed to help you maintain the system without the help of a trained technician. However, do not feel that you must work with the hardware yourself. You can always contact your maintenance provider to have an authorized service provider work with the hardware instead.



**Figure i** Rackmount System Owner's Guide

Figure ii illustrates various sources of information available for using the rackmount graphics system.

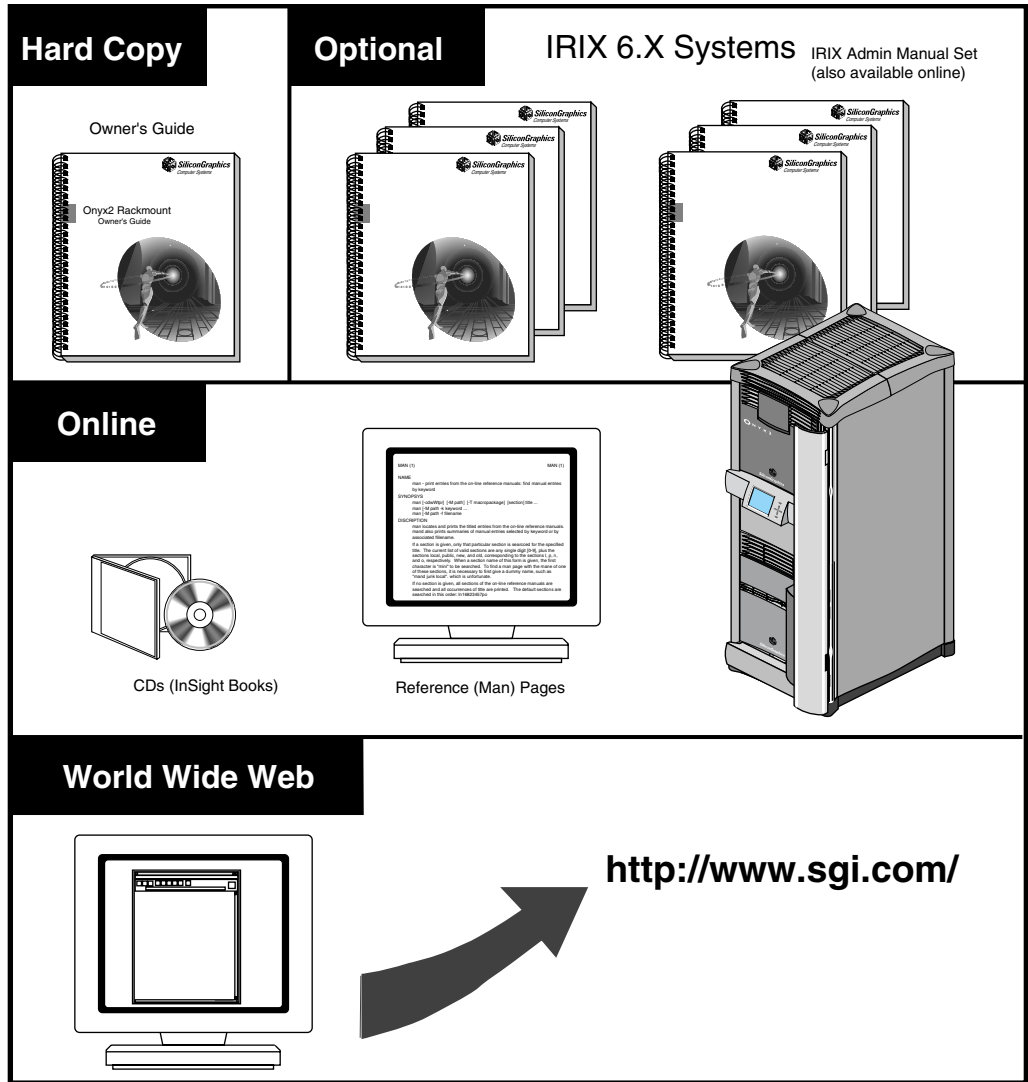


Figure ii Information Sources for the Onyx2 Rackmount System

## Online Reference (Manual) Pages

Your rackmount system comes with a set of IRIX™ reference (manual) pages, formatted in the standard UNIX® “man page” style. These are found online on the internal system disk (or CD-ROM) and are displayed using the *man* command. For example, to display the reference page for the *Add\_disk* command, enter the following command at a shell prompt:

```
man Add_disk
```

Important system configuration files as well as commands are documented on reference pages. References in the documentation to these reference pages include the name of the command and the section number in which the command is found. For example, “Add\_disk(1)” refers to the *Add\_disk* command and indicates that it is found in Section 1 of the IRIX reference.

For additional information about displaying reference pages using the *man* command, see *man(1)*.

In addition, the *apropos* command locates reference pages based on keywords. For example, to display a list of reference pages that describe disks, enter the following command at a shell prompt:

```
apropos disk
```

For information about setting up and using *apropos*, see *apropos(1)* and *makewhatis(1M)*.

## Release Notes

You can view the release notes for a variety of Silicon Graphics® products and software subsystems using one of two utilities:

*relnotes*           Text-based viewer for online release notes.

*grelnotes*         Graphical viewer for online release notes.

To see a list of available Release Notes, type the following at a shell prompt:

```
relnotes (or grelnotes)
```

For more information, see the *relnotes(1)* and *grelnotes(1)* reference pages.

## World Wide Web-Accessible Documentation

Silicon Graphics makes its manuals available in a variety of formats via the World Wide Web (WWW). Using your Web browser, open the following URL:

<http://www.sgi.com/>

- Click on the sales & support menu on the SILICON SURF<sup>SM</sup> page.
- Scroll down the SALES & SUPPORT page and click the category Technical Publications to access the Technical Publications Library.

## Conventions

The *Onyx2 Rackmount Owner's Guide* uses these content conventions:

- References to documents are in *italics*.
- References to other chapters and sections within this guide are in quotation marks.
- Names of IRIX commands that you type at the shell prompt are in *italics* as are IRIX file names.
- Steps to perform tasks are in numbered sentences. When a numbered step needs more explanation, the explanation follows the step.

---

## Introducing the Onyx2 Rackmount System

The Onyx2 rackmount system, model CMN A017, is a graphics supercomputer that is designed to meet the demanding requirements of multimedia, post-production virtual reality, and distributed computing environments. The Onyx2 rack comes in a highly configurable and flexible system architecture that is available in a single rackmount or multirack system. The single rackmount system consists of two to eight R10000™ microprocessors, 128 MB to 4 GB of main memory, a wide variety of I/O interfaces, and one or two individual graphics workstation “pipes” (see Figure 1-1). The Onyx2 multirack configuration can use 4 to 24 R10000 processors and support up to eight individual graphics pipes.

### Rackmount System Features and Options

This section lists the graphics, I/O, and supercomputing features of the Onyx2 rack system.

#### Graphics Features

The rackmount Onyx2 provides features such as

- one to eight graphics-pipe configurations
- optional support of up to eight monitors on each pipe
- a SuperWide (1920 x 1200) high-resolution monitor
- MIDI baud rate and driver
- beeping keyboard for support of “bell”

## **Additional System Features**

Other features of the Onyx2 rackmount system include

- lower entry system cost than Onyx®
- scalable growth of memory and I/O bandwidth as well as processor compute power
- support of a larger number of processors
- high-availability within a single Onyx2 rack system
- high bandwidth I/O connectivity
- high total memory bandwidth
- improved synchronization operations compared with Onyx InfiniteReality™
- large variety of peripheral connectivity options

## **Hardware Overview**

This section provides an overview of the Onyx2 graphics rack system. The block diagrams used generally divide the system in two major functional parts, the I/O compute side and the graphics side.

The graphics hardware subsystem (also known as the graphics module) is generally contained in the top half of the Onyx2 rack. All direct graphics connections to monitors and other video devices are made at the back of the graphics module.

The processor computing subsystem is contained in the bottom half of the Onyx2 rack. This “compute” module supplies processing power, system I/O, keyboard/mouse, and analog and digital audio connections.



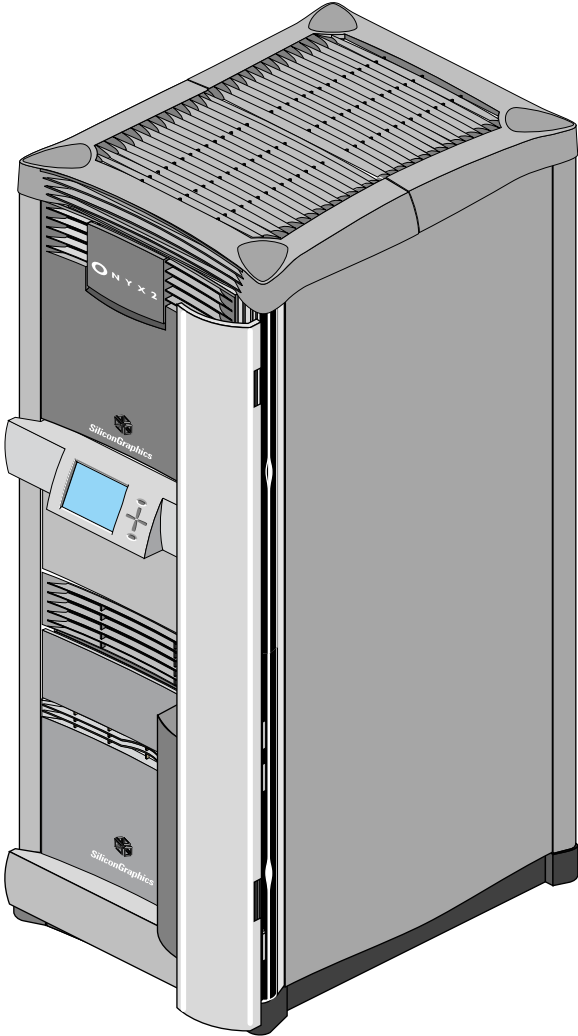
In an Onyx2 rack or multirack system each computing and graphics module has a dedicated module System Controller (MSC), which monitors module status. Each computing module can also have a separate set of hard disks, CPUs, I/O connections, and memory. Two or more computing modules can communicate using the high-speed (800 MBps) CrayLink™ Interconnect links. The CrayLink Interconnect (also known as the interconnection fabric) link consists of a set of high-speed routing switches and cabling that enables multiple connections to take place simultaneously. Using the CrayLink Interconnect, hardware resources (including main memory) can be shared and accessed by another compute module in multirack graphics system.

**Note:** Not all multirack graphics systems have two computing modules; some may have only one.

### **The Single Rack Graphics System**

The single graphics rack Onyx2 is illustrated in Figure 1-1. The rack holds one graphics module and one processor compute module.

Figure 1-2 shows a block diagram example of the graphics rack's potential processor and graphics pipe configurations. The example shows a configuration with four Node boards and two fully loaded InfiniteReality graphics pipes. Each system will vary based on the configuration ordered.



**Figure 1-1** Onyx2 Rackmount Graphics System

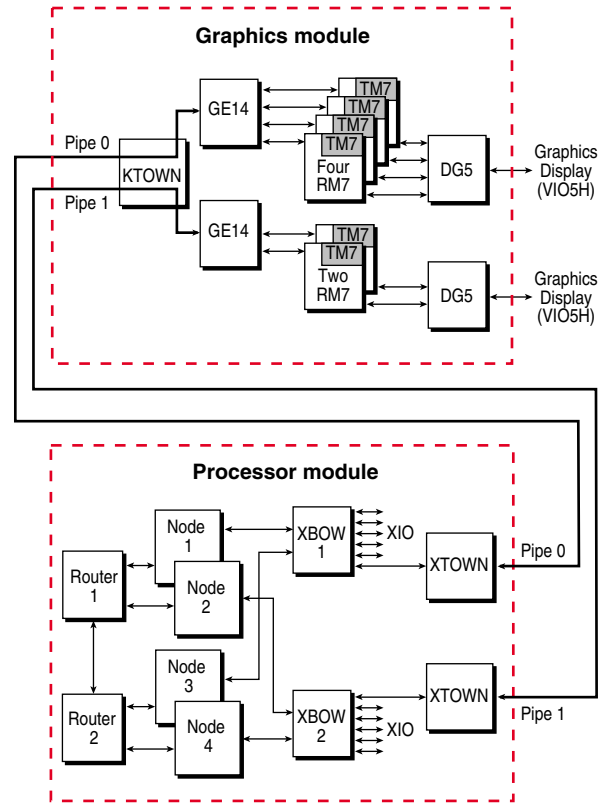
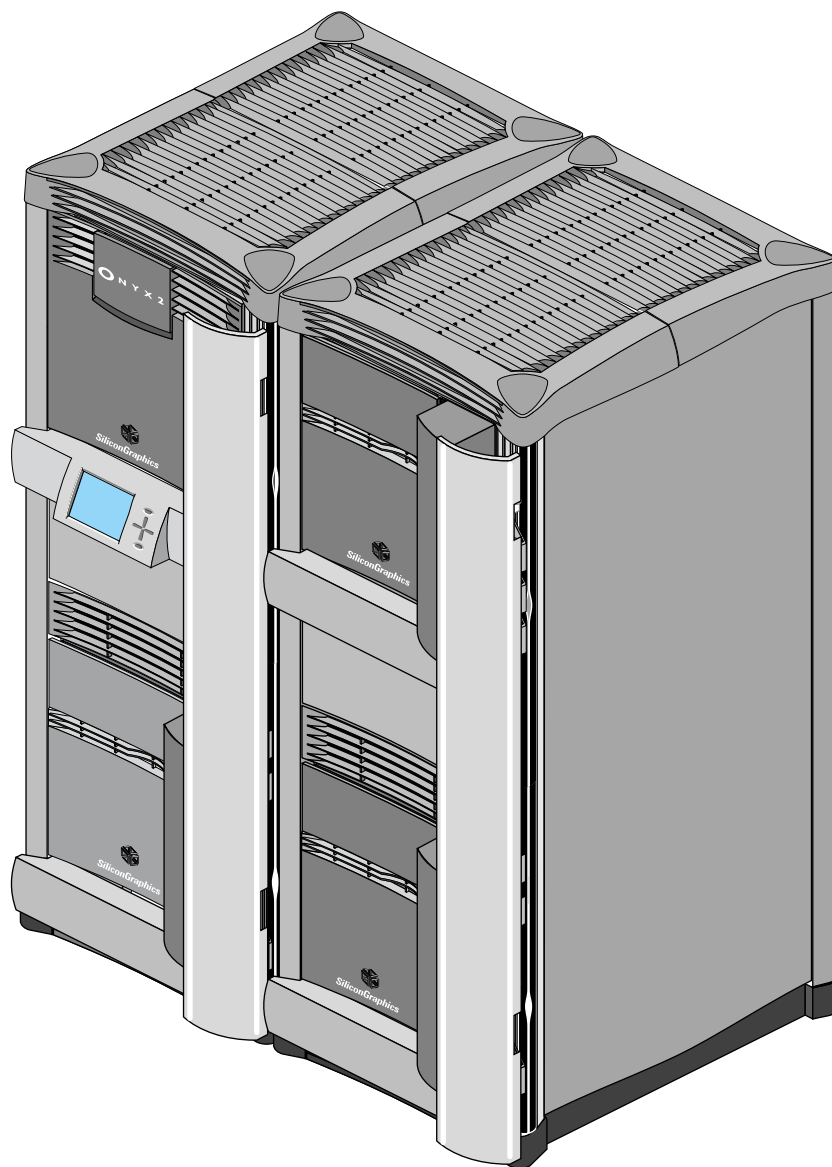


Figure 1-2 Single Rack Graphics Block Diagram Example

## **The Multirack Onyx2**

There are two types of multirack Onyx2 systems: dual rack and triple rack. The multirack Onyx2 system illustrated in Figure 1-3 is a dual rack system. This system can hold up to four modules. The example diagrams in Figure 1-4 and Figure 1-5 show the multirack system with a single compute module and three or four graphics pipes. The multirack Onyx2 system illustrated in Figure 1-6 is a triple rack system, also known as RealityMonster™. This system can hold up to six modules (two compute modules/four graphics modules) and is available in different configurations. The example diagrams in Figure 1-7 and Figure 1-8 show the RealityMonster maximum configuration of sixteen processors and eight graphics pipes. (A RealityMonster maximum configuration requires an Ethernet hub to connect the three multimodule System Controllers (MMSCs)).



**Figure 1-3** Onyx2 Multitrack Graphics System Configuration

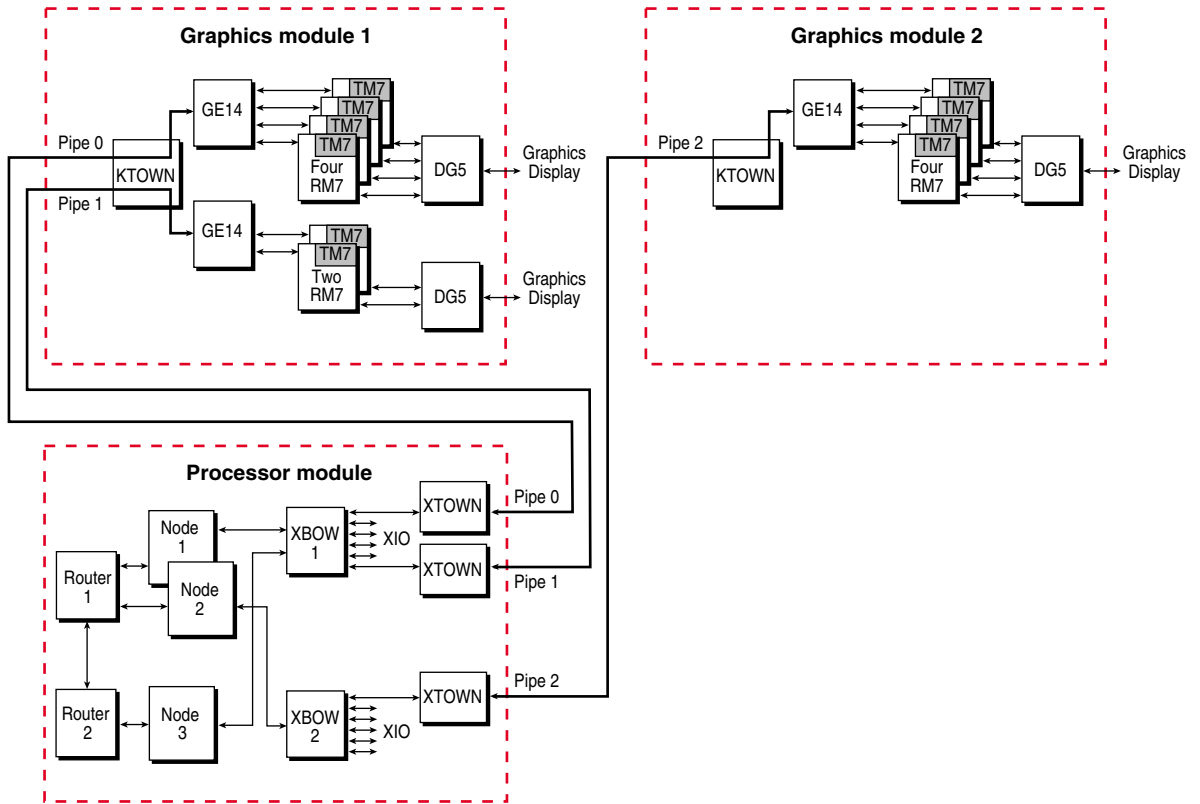


Figure 1-4 Multirack Three-Pipe Diagram Example

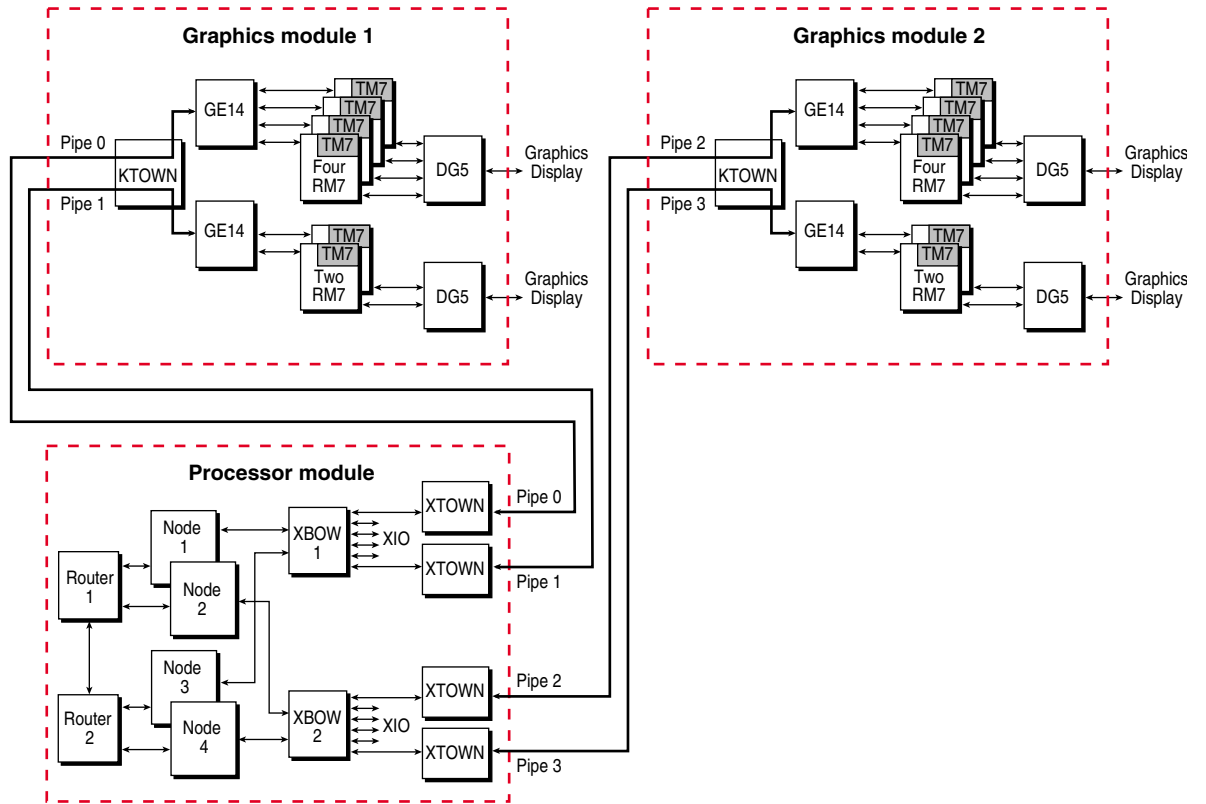
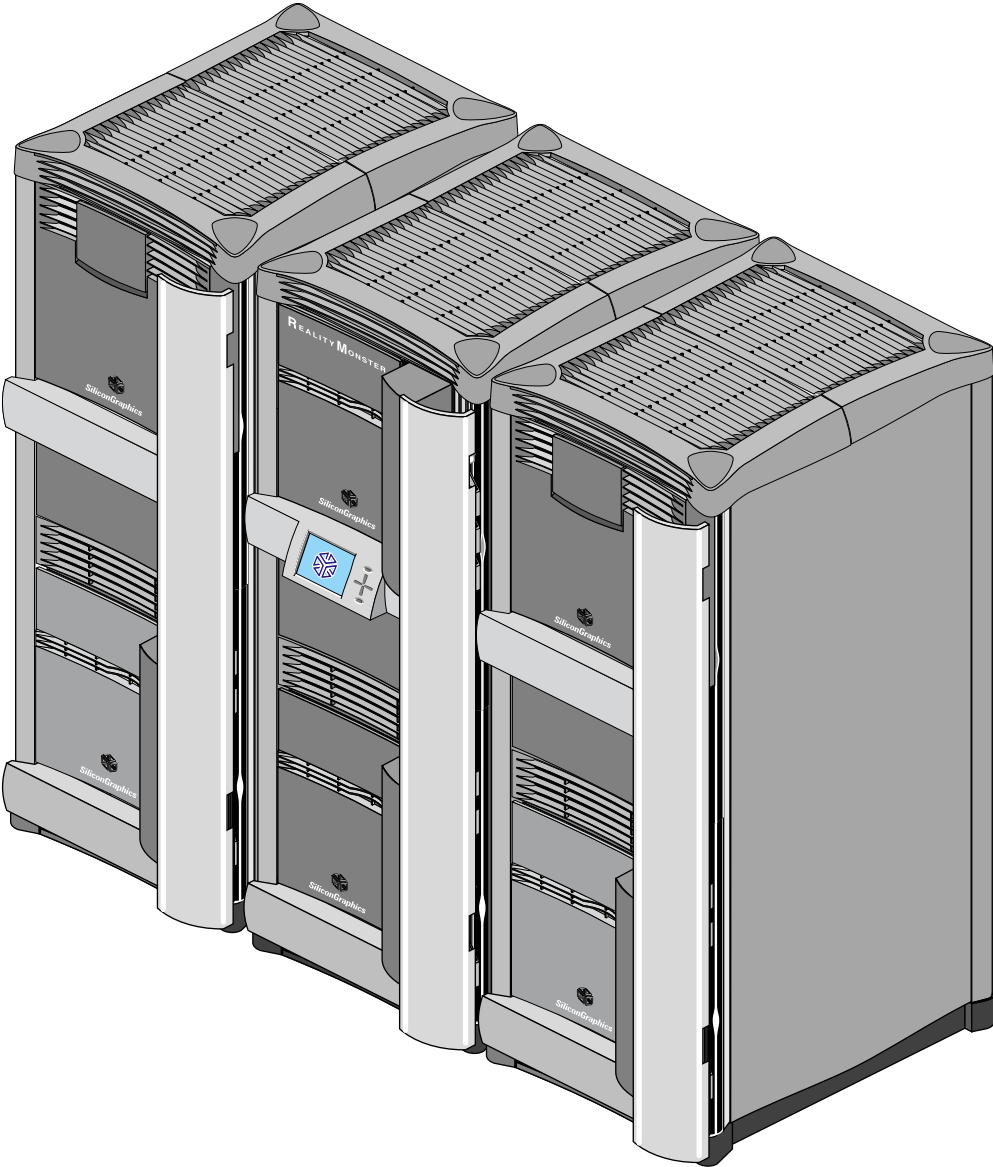


Figure 1-5 Multirack Four-Pipe Diagram Example



**Figure 1-6** RealityMonster Multitrack Graphics System Configuration



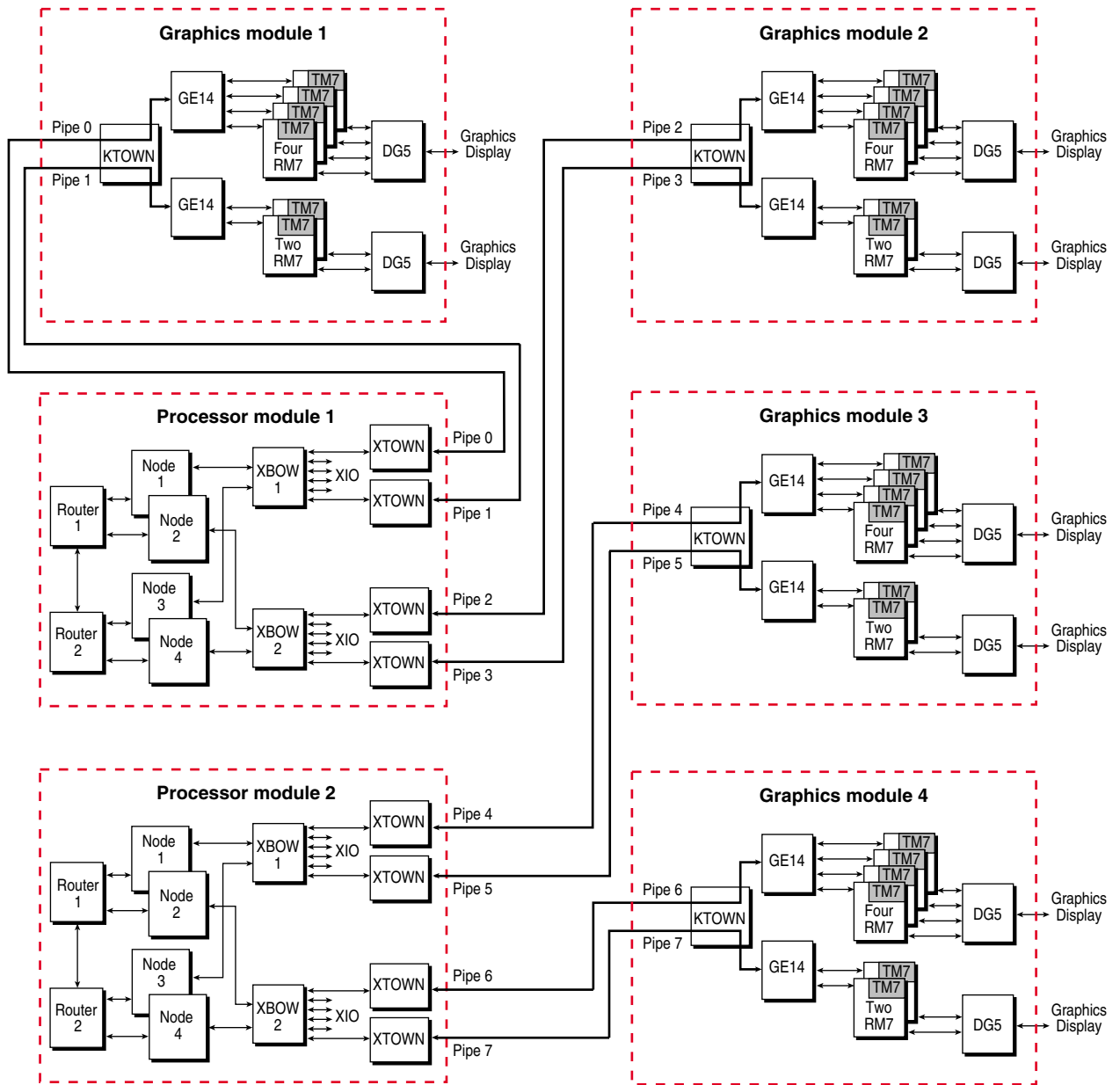


Figure 1-7 RealityMonster Multitrack 16P/8-Pipe Diagram Example

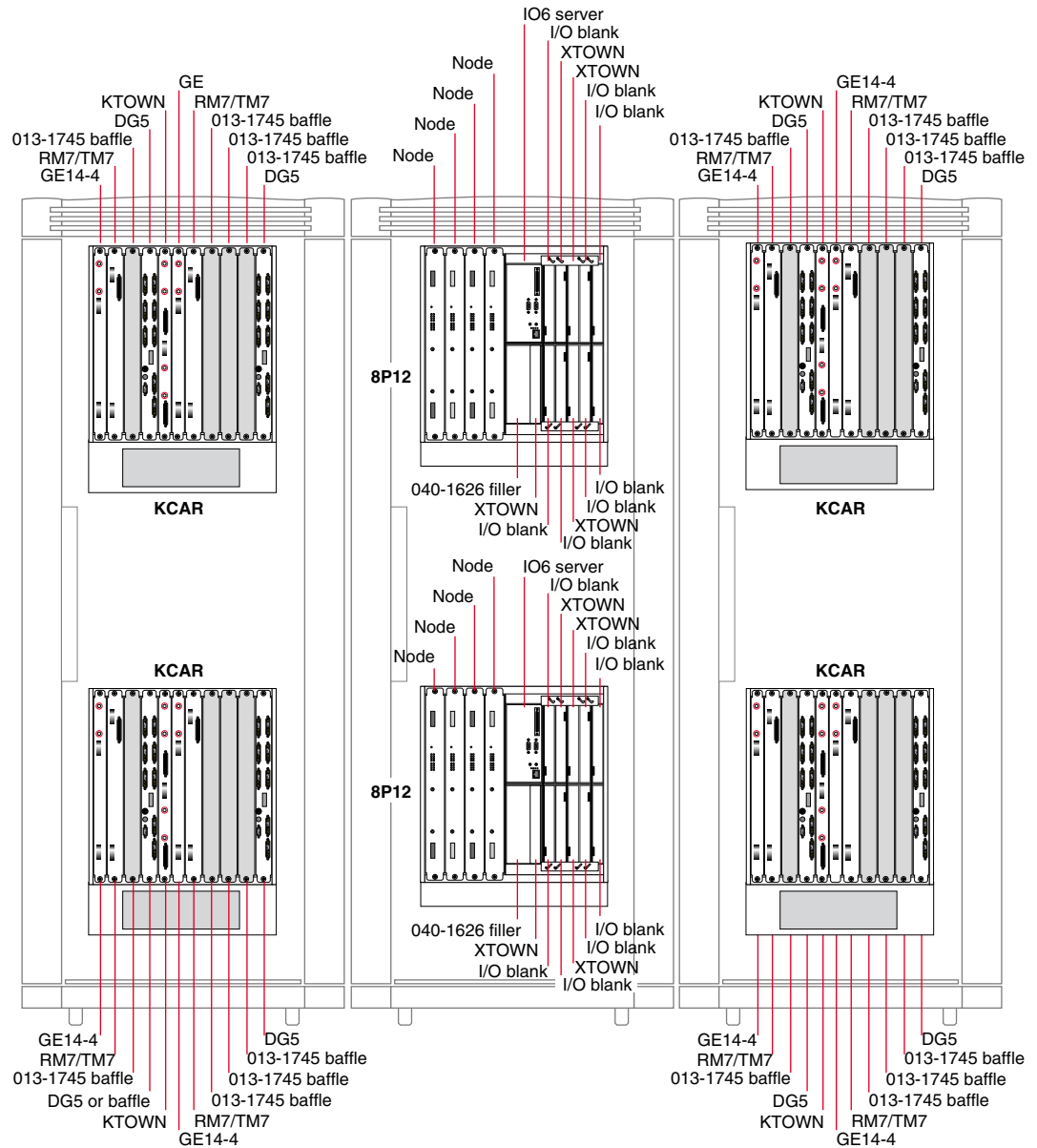


Figure 1-8 RealityMonster Multitrack 16P/8-Pipe Configuration Example

## Graphics Subsystem Overview

The Onyx2 rack system contains one or two InfiniteReality board sets or pipes. One pipe holds one, two, or four RM7/TM7 assemblies and the second uses one or two RM7/TM7 assemblies. The major components of the graphics subsystem are

- GE14
- RM7/TM7 assembly
- DG5
- VI05H (display daughterboard)
- KTOWN interface (for connection to the compute module's XTOWN cable)

## Computing Subsystem Overview

The major hardware components include the

- IP27 Node board(s)
- System disk, MSC, and CD-ROM drive
- Crossbow (XBOW) ASICs on the midplane
- Router board(s)
- BaseIO board (IO6G)
- XIO slots

Each of these components are standard in the computing module.

## Graphics BaseIO Subsystem

The standard I/O subsystem consists of a BaseIO board assembly (also known as IO6G) that supports:

- one 36-pin IEEE 1284-C compatible parallel port
- four 9-pin serial ports (each port software selects for RS-232 or RS-422 operation)
- one single-ended 68-pin Ultra SCSI and SCSI-2 compatible connector
- two 6-pin mini DIN mouse connectors
- two 6-pin mini DIN keyboard connectors
- a 10/100-Mbps Ethernet connection (10Base-T or 100Base-T is automatically selected)
- two analog stereo input 2.5 mm RCA-type jacks
- two analog stereo output 2.5 mm RCA-type jacks
- powered speaker 2.5 mm power jacks
- stereo headphone or powered speaker output 3.5 mm stereo jacks
- analog mono microphone input 3.5 mm jack
- digital audio stereo input (AES-3id-1995) 75-ohm BNC jack
- digital audio stereo output (AES-3id-1995) 75-ohm BNC jack
- optical digital stereo input connector (8-channel ADAT®)
- optical digital stereo output connector (8-channel ADAT)
- two loop-through video sync 75-ohm BNC inputs

Additional I/O connection capabilities are available with optional XIO boards.

## Onyx2 Graphics Rack Functional Overview

The compute module in the Onyx2 graphics rack uses a new concept in symmetric multiprocessing systems that has a distributed shared-memory architecture called S2MP™ Architecture. This is a revolutionary (rather than evolutionary) technology step for Silicon Graphics systems.

### Linked Microprocessors

The Node boards within the Onyx2 compute module use links that differ from bus technology. While a bus is a resource that can be used by only one processor at a time, the communications “fabric” in the Onyx2 rack makes connections from processor to processor as they are needed. Each Node board contains either one or two processors, a portion of main memory, a directory to maintain cache coherence, and two interfaces:

- The first interface connects to multiple I/O devices.
- The second interface connects to the second Node board through the S2MP interconnect.

This web of connections differs from a bus in the same way that multiple dimensions differ from a single dimension. You could describe a bus as a one-dimensional line while the Onyx2 uses a multidimensional mesh.

The multiple data paths used are constructed as they are needed by router ASICs, which act as switches. When you add a Node board, you add to and scale the system bandwidth.

## Multirack Interconnect Features

In the case of a multirack graphics system with more than one compute module, the CrayLink Interconnect links modules to one another. The CrayLink Interconnect may appear to be a type of super data bus, but it differs from a bus in several important ways. Basically, a bus is a resource that can be used only by one processor at a time. The CrayLink Interconnect is a mesh of multiple, simultaneous, dynamically allocable connections that are made from processor to processor in the connected compute modules.

This makes the Onyx2 multi-rack system very scalable because it can range in size from 4 to 24 processors. As you add Node boards or compute modules, you add to and scale the system bandwidth.

The CrayLink Interconnect uses a set of switches, called *routers*, that are linked by cables in various configurations, or *topologies*. Here are some key features:

- The CrayLink Interconnect is a mesh of multiple point-to-point links connected by the routing switches. These links and switches allow multiple transactions to occur simultaneously.
- The links permit extremely fast switching (a peak rate of 1600 MBps bidirectionally, 800 MBps in each direction).
- The CrayLink Interconnect does not require arbitration, nor is it limited by contention.
- More routers and links are added as nodes are added, increasing the CrayLink Interconnect's bandwidth.

The CrayLink Interconnect provides a minimum of two separate paths to any pair of compute modules. This redundancy allows the system to bypass failing routers or broken fabric links. Each fabric link is additionally protected by a CRC code and a link-level protocol, which retry any corrupted transmissions and provide fault tolerance for transient errors.

## S2MP Architecture and Memory

Main memory on each Node board in the system can be distributed and shared among the system microprocessors. This shared memory is accessible to all R10000 processors in a compute module through the S2MP architecture. The CrayLink interconnection fabric provides inter-module accesses with low latency.

Each Node board in the graphics rack system is an independent memory source, and each Node board is capable of optionally supporting up to 4 GB of memory. A directory memory keeps track of information necessary for hardware coherency and protection.

Each Node board uses a HUB ASIC that is the distributed shared-memory controller. This ASIC is responsible for providing all of the processors and I/O devices with transparent access to all of distributed memory in a cache-coherent manner. Cache coherence is the ability to keep data consistent throughout a system. In the Onyx2 system, data can be copied and shared amongst all the processors and their caches. Moving data into a cache may cause the cached copy to become inconsistent with the same data stored elsewhere. The cache coherence protocol is designed to keep data consistent and to disperse the most-recent version of data to wherever it is being used.

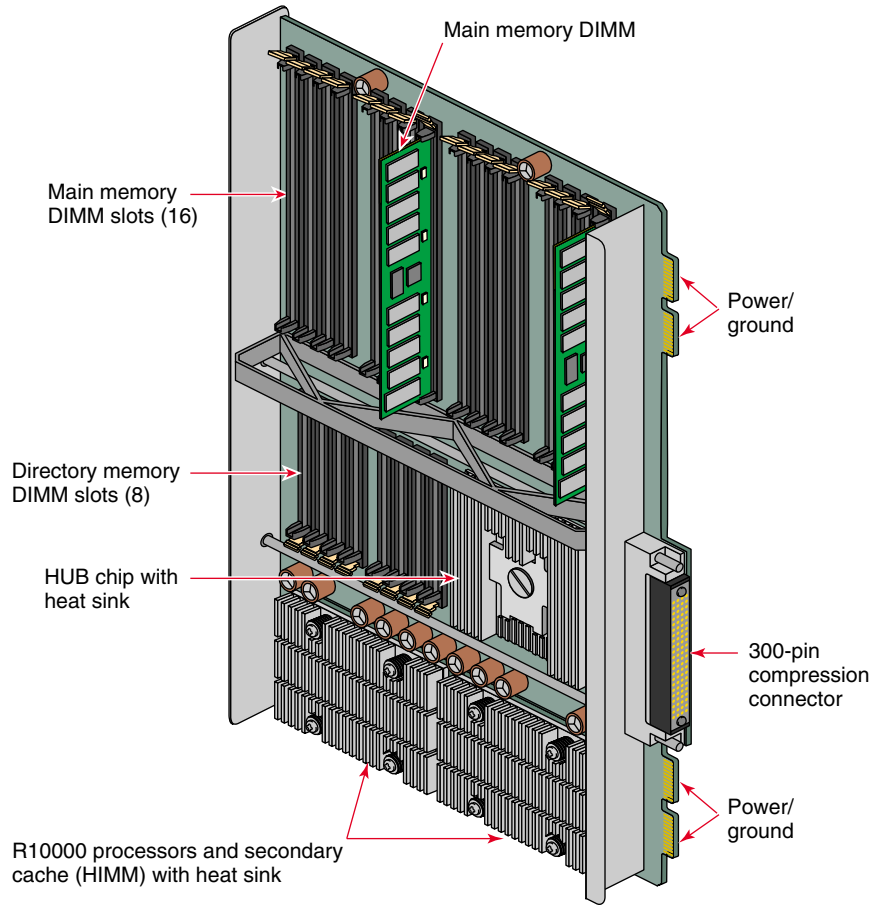
Although memory is physically dispersed across the system Node boards, special page migration hardware moves data into memory closer to a processor that frequently uses it. This page migration scheme reduces memory *latency*—the time it takes to retrieve data from memory. Although main memory is distributed, it is universally accessible and shared between all the processors in the system. Similarly, I/O devices are distributed among the Nodes, and each device is accessible to every processor in the system.

## The Node Boards

The Onyx2 graphics rack's microprocessor "brains" and primary memory are located on a processor board called a Node board. Each Node board in the Onyx2 graphics rack can house one or two R10000 microprocessors. Each 3.45-V R10000 uses a customized two-way interleaved data cache, and has dedicated second-level cache support. A high-performance bus interface links the CPU directly with supporting SRAM.

The Node board's main memory slots can be populated with 32 MB or 64 MB memory modules. See Figure 1-9 for an example Node board illustration.

Note that directory memory is used only in large scale multirack systems; there is no reason to use directory memory in a single-rack system.



**Figure 1-9** Node Board Example



## **XIO Boards**

XIO boards give the graphics rack system a wide range of optional interfaces in a manner similar to VME interfaces. Optional XIO boards can support communication interfaces such as

- FDDI
- Fibre Channel
- HIPPI
- Multiport Ultra (Fast-20) SCSI and SCSI-2
- ATM
- Multiport Ethernet

Check with your Silicon Graphics sales or support representative for information on these or other optional interfaces available on XIO boards.

## **Compute Module Midplane**

Each processor compute module in an Onyx2 graphics rack system uses a midplane. This means that boards, disk drives, and other devices can plug into both sides of the system. This allows for maximum functionality and expansion.

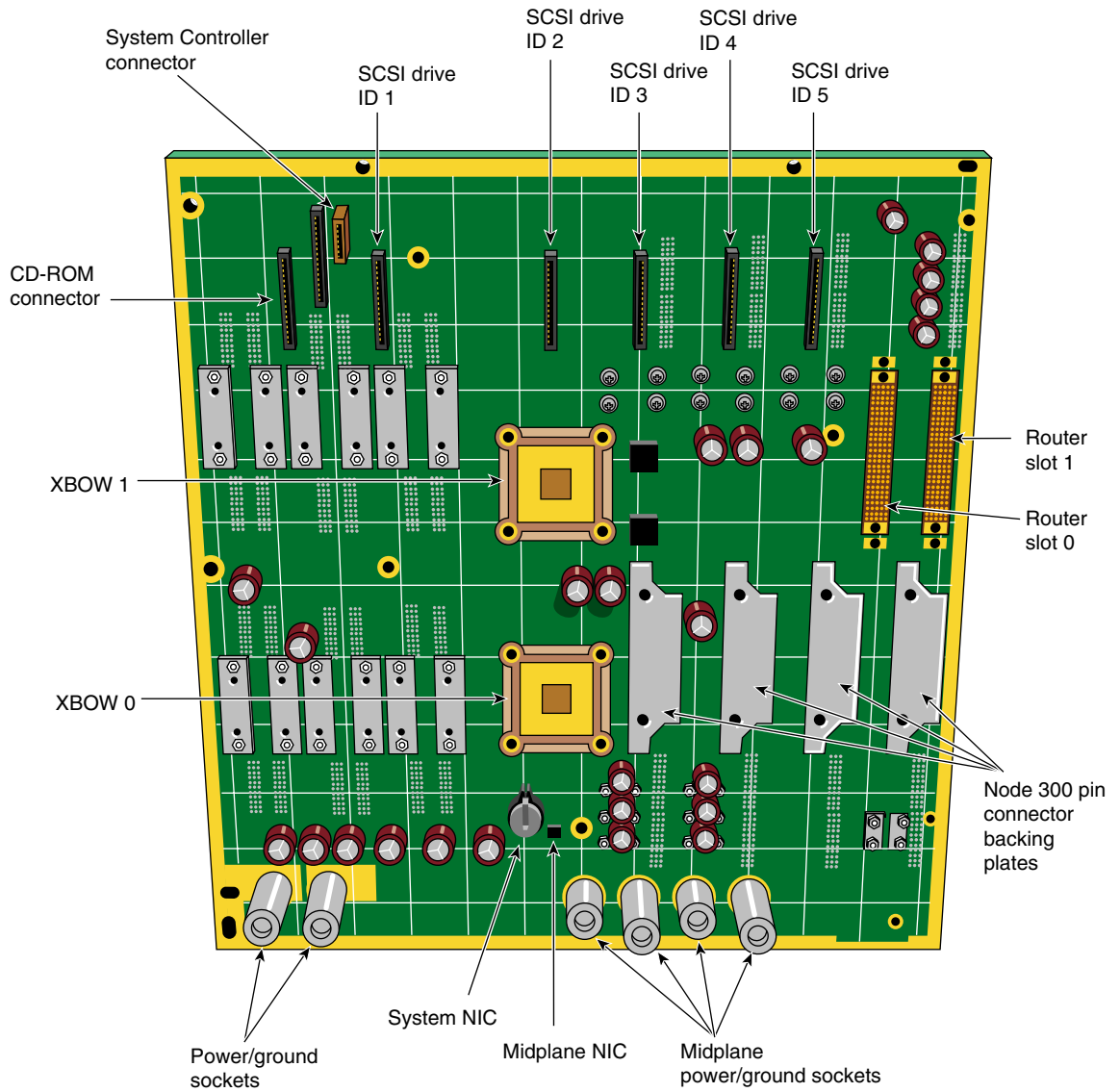
Single-ended Ultra SCSI and SCSI-2 disk, CD-ROM, and tape drives are the only devices internally supported by the Onyx2 graphics rack systems.

Figure 1-10 shows the front of the processor compute module's midplane.

## **Graphics Module Midplane**

The rack system's graphics module uses a midplane in a similar way to the processor compute module. However, it does not have any disks or CD-ROM connections on the front. Only the MSC and power supply connections are made in the front. All graphics and interface boards go in the rear of the module and connect to the back of the midplane.

Figure 1-11 shows a view of the graphics module midplane.



**Figure 1-10** Processor Compute Module Midplane

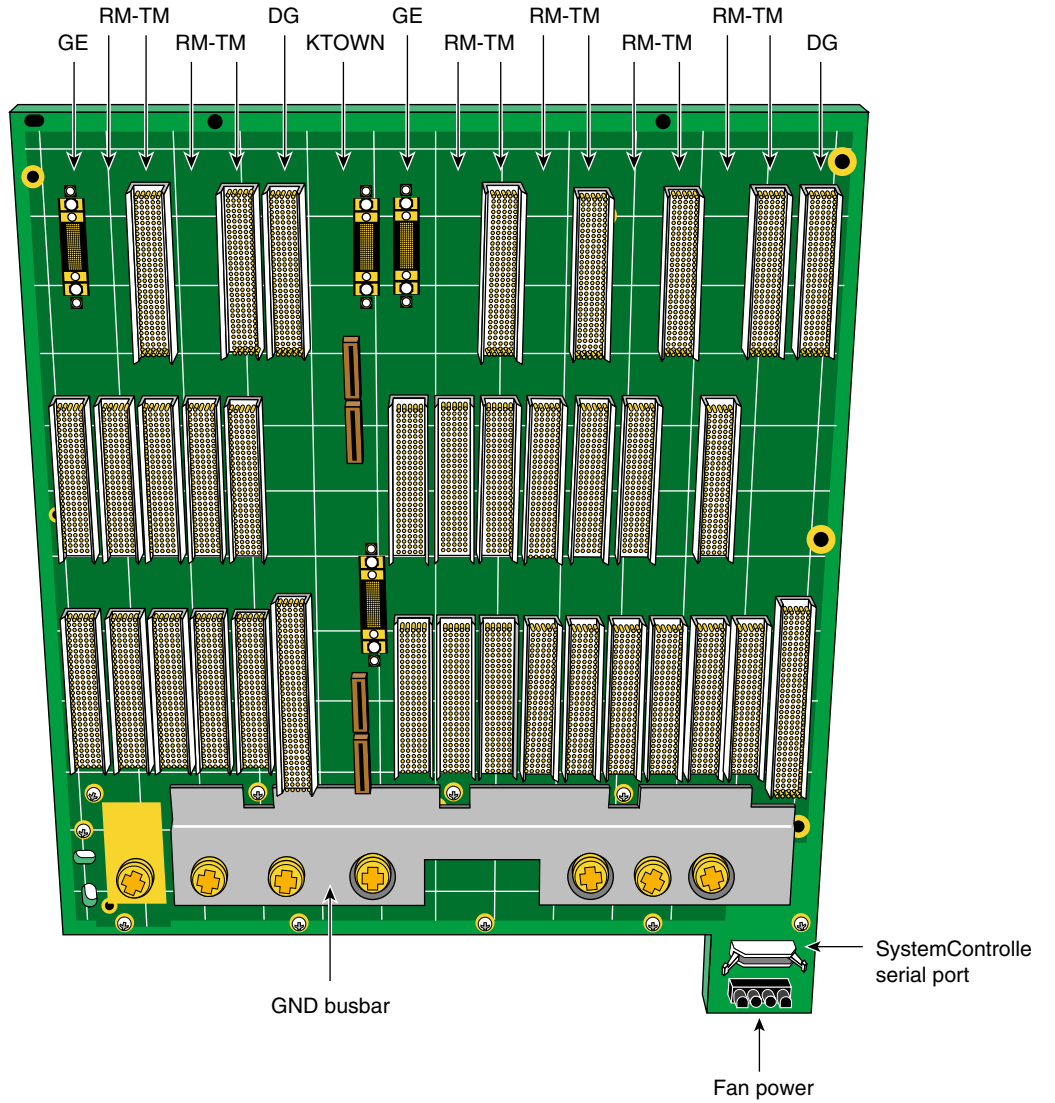


Figure 1-11 Graphics Module Midplane

## System Location and Environment

This section covers the basic requirements for physical location of the rack to ensure proper chassis operation.

As a general rule, the rack system is intended for a lab or “machine room” environment.

The rack(s) should be protected from harsh environments that produce excessive vibration, heat, and similar conditions.

The rack system should be kept in a clean, dust-free location to reduce maintenance problems.

For questions concerning physical location or site preparation, see the *Site Preparation for Origin Family and Onyx2* manual (P/N 007-3452-001 or later version). If you are unable to find the information you need, contact your Silicon Graphics System Support Engineer (SSE) or other authorized support organization representative.

Table 1-1 provides the basic physical specifications for the Onyx2 rack system.

**Table 1-1** Rack System Physical Specifications

Parameter		Specification
Dimensions:		
Installed:	length	39" (99 cm)
	width	29" (74 cm)
	height	73" (185 cm)
Shipping:	length	81" (206 cm)
	width	47" (120 cm)
	height	49" (125 cm)
Weight:	minimum (empty rack)	300 lbs (136 kg)
	maximum (full rack)	750 lbs (340 kg)
	shipping (maximum)	900 lbs (408 kg)
Floor Loading:	minimum	38 lb/ft <sup>2</sup> (185 kg/m <sup>2</sup> )
	maximum	95 lb/ft <sup>2</sup> (466 kg/m <sup>2</sup> )
Air Temperature:	operating (< 5000 ft)	41° to 95° F (5° to 35° C)
	operating (> 5000 ft)	41° to 86° F (5° to 30° C)
	non-operating	-4° to 140° F (-20° to 60° C)

**Table 1-1 (continued)** Rack System Physical Specifications

<b>Parameter</b>		<b>Specification</b>
Thermal Gradient:	maximum	18° F (10° C) per hour
Altitude:	operating	10,000 ft (3,048 m) MSL, maximum
	non-operating	40,000 ft (12,192 m) MSL, maximum
Humidity:	operating	10-90% (non-condensing)
	non-operating	10-95% (non-condensing)
Humidity Gradient:	maximum	10% relative humidity per hour
Acoustics:	typical	55 dBa
Vibration:	max. sustained, oper.	5-10 Hz @ .01" total excursion, 10-500 Hz @ 0.1g
	max. peak, operating	5-10 Hz @ .02" total excursion, 10-500 Hz @ 0.1g
	sensitive freq., oper.	8-33 Hz (varies with configuration)



## Chassis Tour

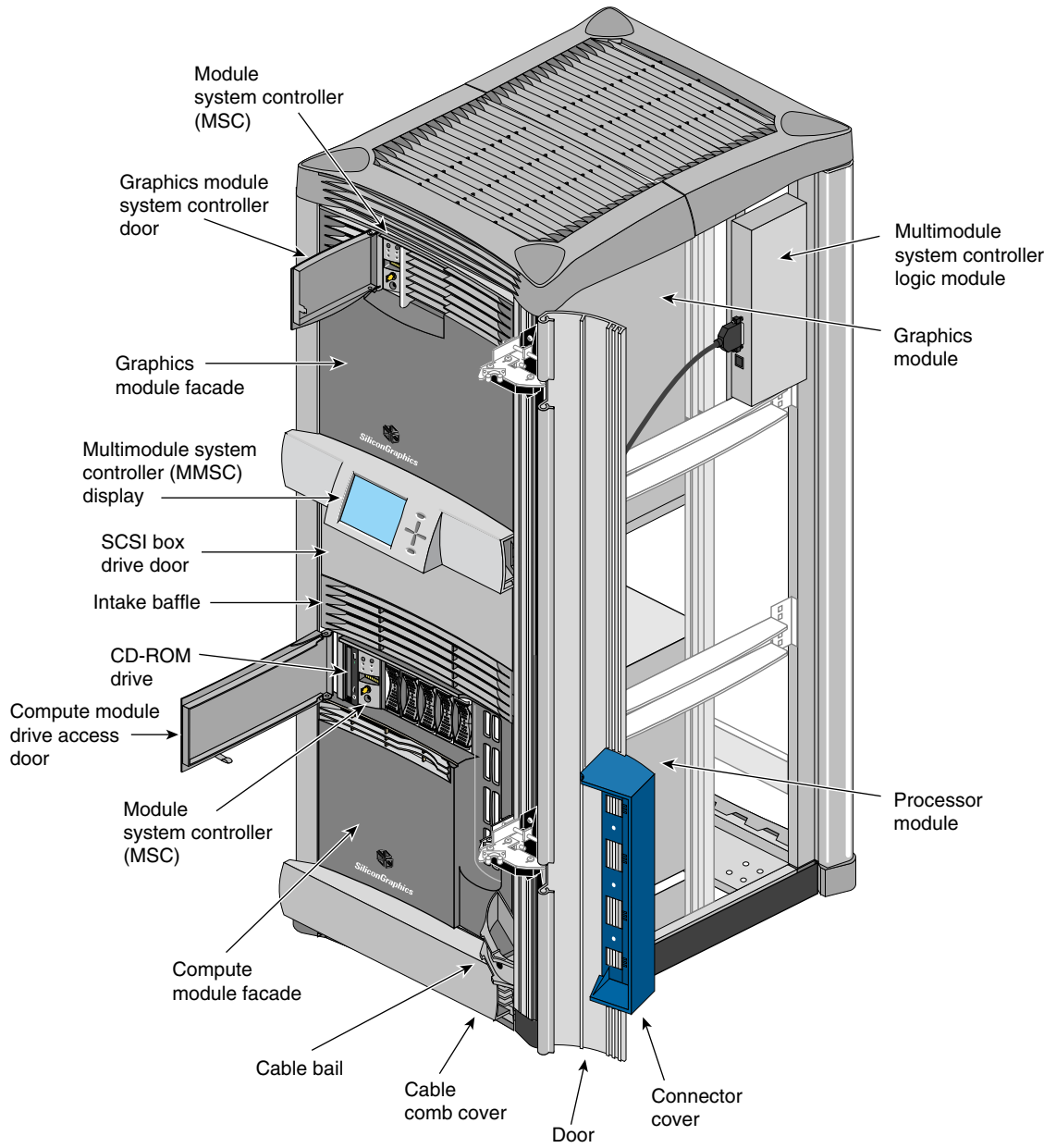
This chapter provides an overview of the rackmount system chassis and a description of the controls, connectors, and indicators.

System component topics covered include

- “Graphics Rack Chassis”
- “Graphics Module Components”
- “Compute Module Components”
- “Node Boards”
- “Graphics Rack System Controllers”
- “Router Boards”

### Graphics Rack Chassis

Figure 2-1 and Figure 2-2 show the major parts of the Onyx2 graphics rack system.



**Figure 2-1** Onyx2 Rackmount System



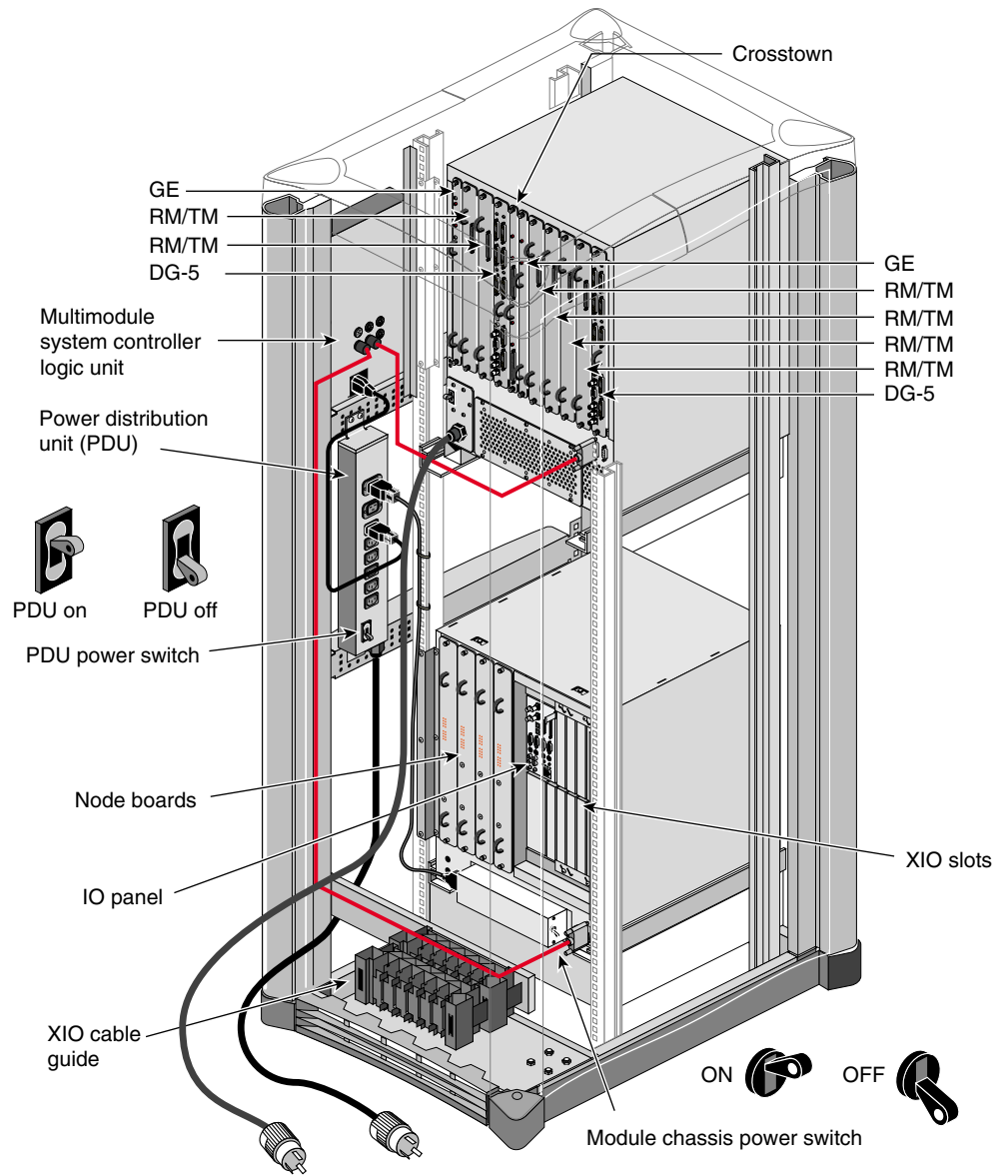
Table 2-1 provides a list of major components on the front of the graphics rack (from top to bottom). A brief functional description of each component is provided.

**Table 2-1** Major Components on the Front of the Graphics Rack

Component	Description
Graphics module and System Controller (MSC)	The graphics module(s) in the Onyx2 rack contains all the video interface and graphics boards. Each module supports one or two graphics pipes and a maximum of 16 monitors. The module's System Controller (MSC) is a part of each module. Its microprocessor reports module status information to the rack's multimodule System Controller (MMSC).
Graphics module System Controller access door	This door provides access to the graphics module System Controller.
Multimodule System Controller (MMSC) interface and display	The MMSC display is an intelligent keypad interface that can control all modules in a rack system. The MMSC display panel is a color screen. There is one MMSC display panel per Onyx2 rack configuration.
Origin Vault™ SCSI drive box	This drive box enclosure provides six 3.5-inch and two 5.25-inch half-height drive slots for single-ended SCSI drives.
Air intake baffle	This baffle helps proper airflow through the rack. Note that the top of the rack has a vent as well. Airflow is generally pulled in from the top and front of the rack and exhausted through the back of the rack.
Compute module System Controller CD-ROM and disk drives	One CD-ROM is standard with each graphics rack system. The MSC sits next to the CD drive. The system disk contains the operating system and other key software directories and is always installed to the right of the MSC. Up to five optional SCA (single-connector assembly) data disks install to the right of the system disk. All disks are single-ended, ultra SCSI, or SCSI-2 drives with a transfer rate of up to 40 MBps.
Compute (processor) module	Compute modules in Onyx2 graphics rack systems provide an independent computing subsystem with a separate set of CPUs, disks, a System Controller, audio, and I/O connections.
Facade	The removable facade covers the power supply and Router boards for each module in the rack chassis.

**Table 2-1 (continued)** Major Components on the Front of the Graphics Rack

<b>Component</b>	<b>Description</b>
CrayLink Interconnect cabling	This is the physical link that enables different compute modules in a multirack graphics system to communicate and share resources. The CrayLink Interconnect cable is made up of delicate copper strands. Be careful when handling this cable.
Cable bail	The cable bales hold any CrayLink Interconnect cables in place to prevent excessive cable bending, which can cause damage.
Cable comb cover	This removable cover hides any CrayLink Interconnect cables inside the rack chassis.
Cable comb	The comb holds the CrayLink Interconnect in place when the cable is tucked into the grooves.
Cable door	The cable door hides the CrayLink Interconnect routing between modules in a multirack system.
Connector cover	The connector cover protects the Router board ports and cabling.



**Figure 2-2** Onyx2 Rack System (Rear View)

Table 2-2 lists and describes the major components seen at the back of the Onyx2 rack.

**Table 2-2** Onyx2 Graphics Rack Rear Components

Component	Description
Graphics boards	The system graphics boards are located in the rear of the graphics module. All video connections are made at this location.
Multimodule System Controller (MMSC) logic unit	The MMSC located in the rear of the chassis is a separate microprocessor-controlled unit that interfaces the individual module's MSCs and with another MMSC in a multirack system.
Power distribution unit (PDU)	The PDU is the central power source for the rack. The compute module and Origin Vault peripherals box connect to the PDU. Note that the PDU has a separate on and off power switch.
PDU switch	The PDU switch is the main circuit breaker for the rack's compute module, Origin Vault drive box, and MMSC assembly.
Node board(s)	Node boards are the processing boards in the Onyx2 system. Each contains two R10000 CPUs, the HUB ASIC (which provides an interface to the I/O subsystem), the CrayLink Interconnect, a portion of main memory, and optional directory memory. Each Node board can support from 64 MB to 4 GB of memory. A single-rack system can have one to four Node boards. A multirack system can have up to 12 Node boards.
Graphics BaseIO board (I/O panel)	This board (also known as the IO6G) provides basic I/O functions for the graphics system, such as digital and analog audio ports, serial ports, 10/100BaseT Ethernet, and single-ended wide SCSI. A dedicated slot in the XIO cardcage houses the graphics BaseIO board. This board cannot be installed in any of the other XIO expansion slots.
XIO slot cardcage	The XIO cardcage allows you to install additional I/O boards into the processor compute module chassis.
XIO cable guide	The XIO cable guide management helps to ensure proper laying out of cables in the rear of the chassis.
Module chassis power switch (circuit breaker)	This switch powers the individual modules on and off.

## Graphics Module Components

The graphics module almost always sits in the top part of the rack system. Exceptions to this rule are found in certain multirack Onyx2 graphics systems configured for maximum graphics pipe support.

Each graphics module holds up to two sets of InfiniteReality graphics boards (two pipes). Each pipe supports up to eight monitors.

The pipe on the right of the graphics module (as seen from the back) supports one, two, or four RM/TM assemblies (see Figure 2-3). It is supported by the top KTOWN cable connection on the KTOWN board. The pipe on the left supports one or two RM/TM assemblies and connects to the bottom KTOWN board connector.

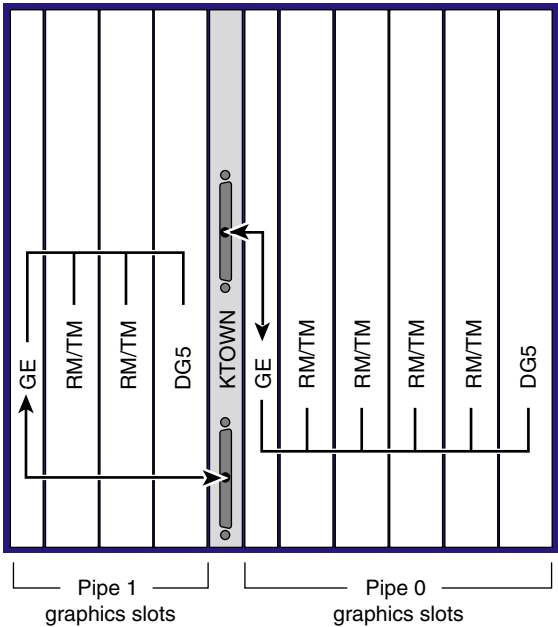
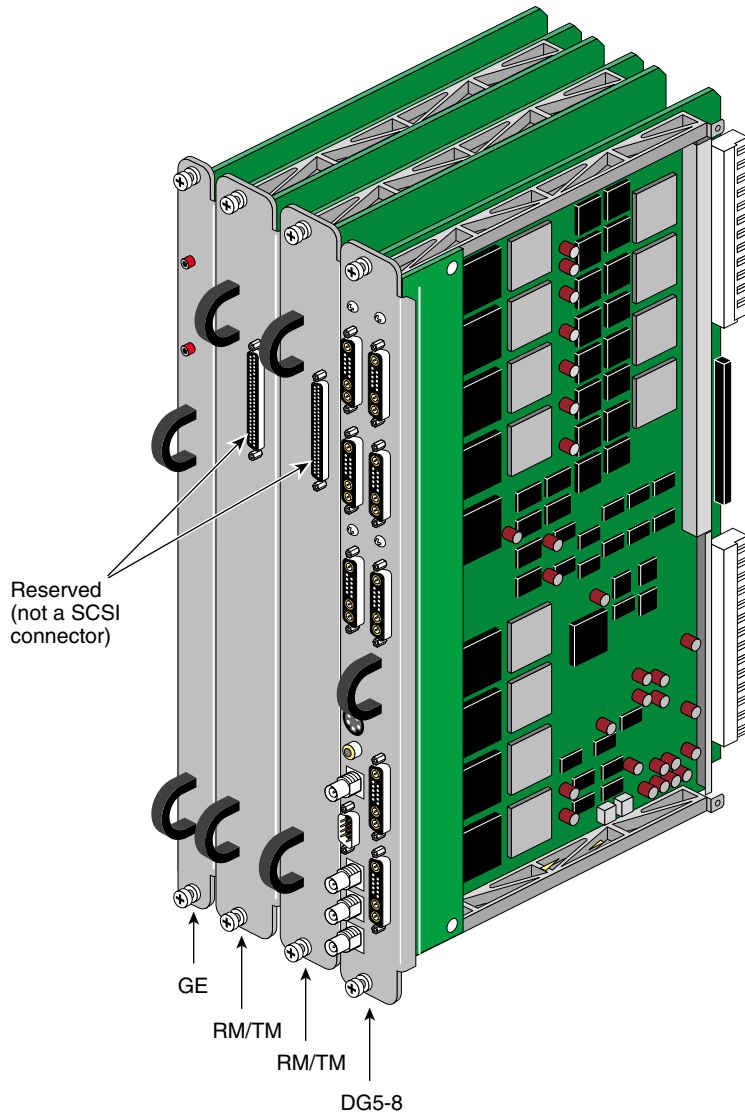


Figure 2-3 Graphics Module Pipes Diagram

Figure 2-4 shows an example of a two-RM InfiniteReality graphics board set that is supported by the rack's graphics module. Note that the 68-pin connectors on the RM/TM assemblies are reserved for caligraphics lights; they are *not* for SCSI drives.



**Figure 2-4** Graphics Pipes in the Module

## Compute Module Components

The following sections describe major hardware components specific to the Onyx2 graphics rack compute module.

### Board Configurations

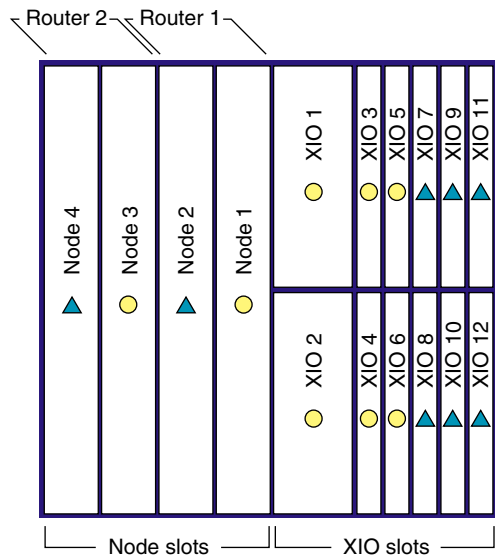
There is a direct correlation between the number of Node boards installed in the system's compute module and the number of XIO slots that can be activated.

If a system compute module has only one Node board, then only 6 of the 12 XIO slots are activated. When two Node boards are installed, all 12 of the XIO slots can be activated, *if* the Node boards are positioned in the correct slots.

Figure 2-5 diagrams the Node-board-to-XIO-board correlation. The Node boards and their corresponding XIO board slots are indicated with either a circle or triangle. When Node 1 is present, XIO slots 1 through 6 (designated by a circle) are activated. When Node 2 is also present, then XIO slots 7 through 12 (designated by a triangle) are activated.

Node boards 3 and 4 also have corresponding XIO slots indicated by a circle or a triangle. For example, if Node boards are installed in slot 1 and slot 3, then only the corresponding XIO slots (1 through 6) are activated.

Rear Chassis Diagram



Block Diagram

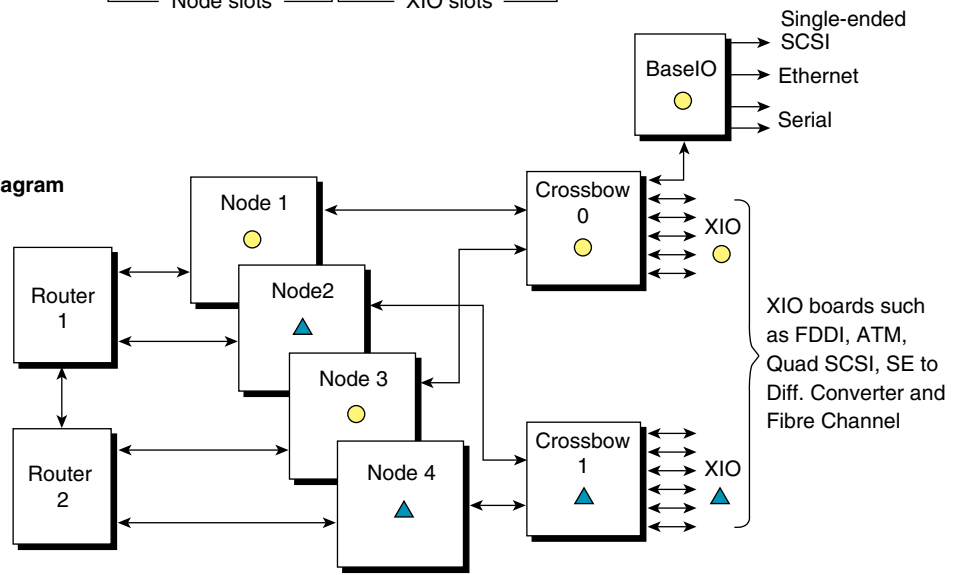
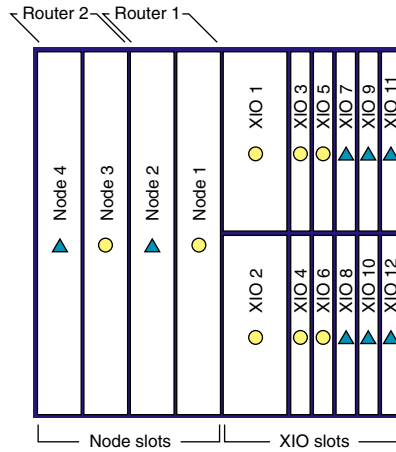


Figure 2-5 Block Diagram for the Compute Module (Single Rack)



Rear Module Diagram



Block Diagram

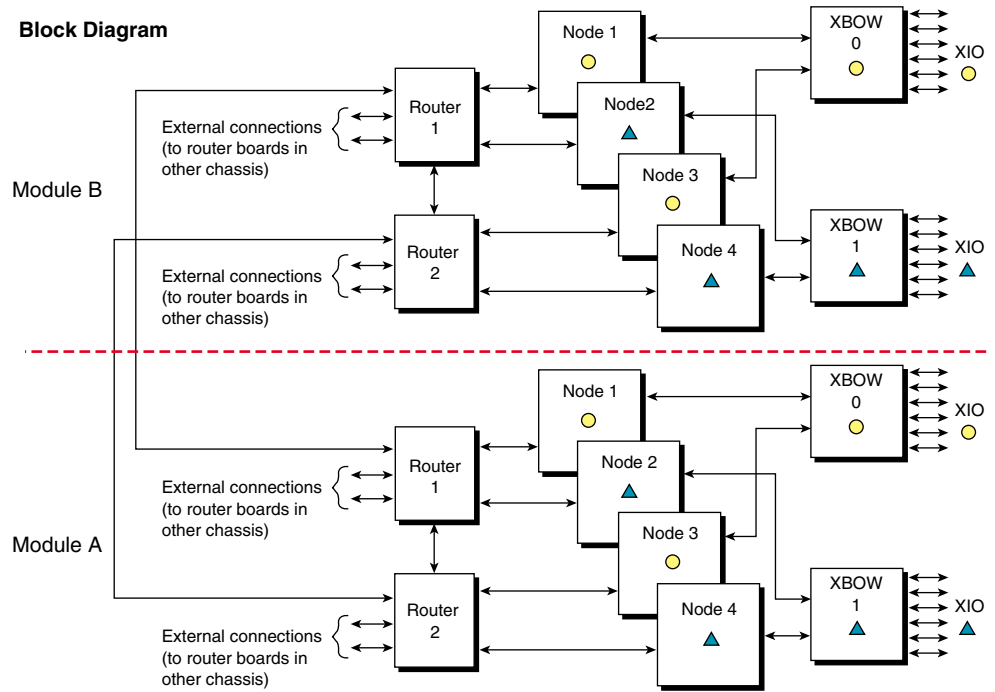


Figure 2-6 Block Diagram for the Compute Modules (Multitrack System)

## XIO Boards

Note that the graphics BaseIO interface board assembly uses one of the XIO slots. Various types of optional interface boards are supported in the XIO slots. These may include:

- Fibre Data Distributed Interface (FDDI)
- High-performance point-to-point interface (HIPPI)
- Multiple Ethernet board
- Multiple SCSI port board
- Digital I/O Video Option (DIVO) interface board

Certain installation restrictions must be followed when XIO boards are installed or removed. Failure to follow these configuration rules may result in system or peripheral malfunction.

Always ensure these XIO rules are followed:

- Keep the graphics BaseIO (IO6G) board assembly installed in XIO slot 1.
- Fill the top XIO slots first.
- The optional PCI module is installed in XIO slot 2.

Never allow any of these configurations:

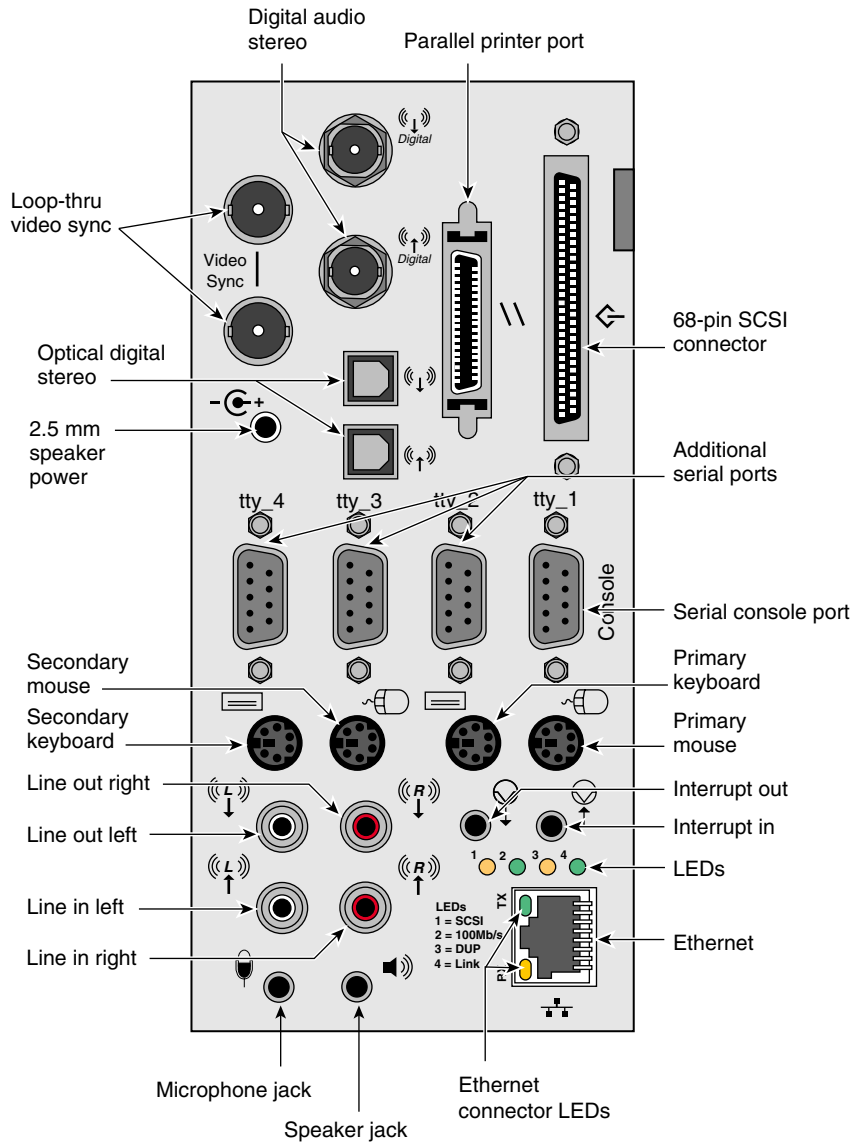
- Move the BaseIO (IO6G) board assembly to a slot other than XIO 1.
- Have a SCSI board installed in XIO slot 2.
- Have an XIO board installed in an unsupported slot.

Node board slots are counted from right to left. Router board and XIO board slots are counted from left to right. Refer back to Figure 2-5 for a diagram of the back of the compute module that differentiates the supported XIO slots. The circles and triangles represent the interdependence of the XIO slots and the Node boards that support them.

## BaseIO Panel

The graphics BaseIO panel assembly (also known as the IO6G) installs in XIO board slot one and is used to connect external devices to the system. These devices include keyboards, mice, SCSI devices, audio devices, ASCII terminals, printers, and modems. The I/O panel configuration is shown in Figure 2-7.

**Note:** If you disconnect a cable from a peripheral device, you should also disconnect it from the I/O connector on the I/O panel. This helps prevent the system from picking up external electrical noise. Connectors are listed in Table 2-3.



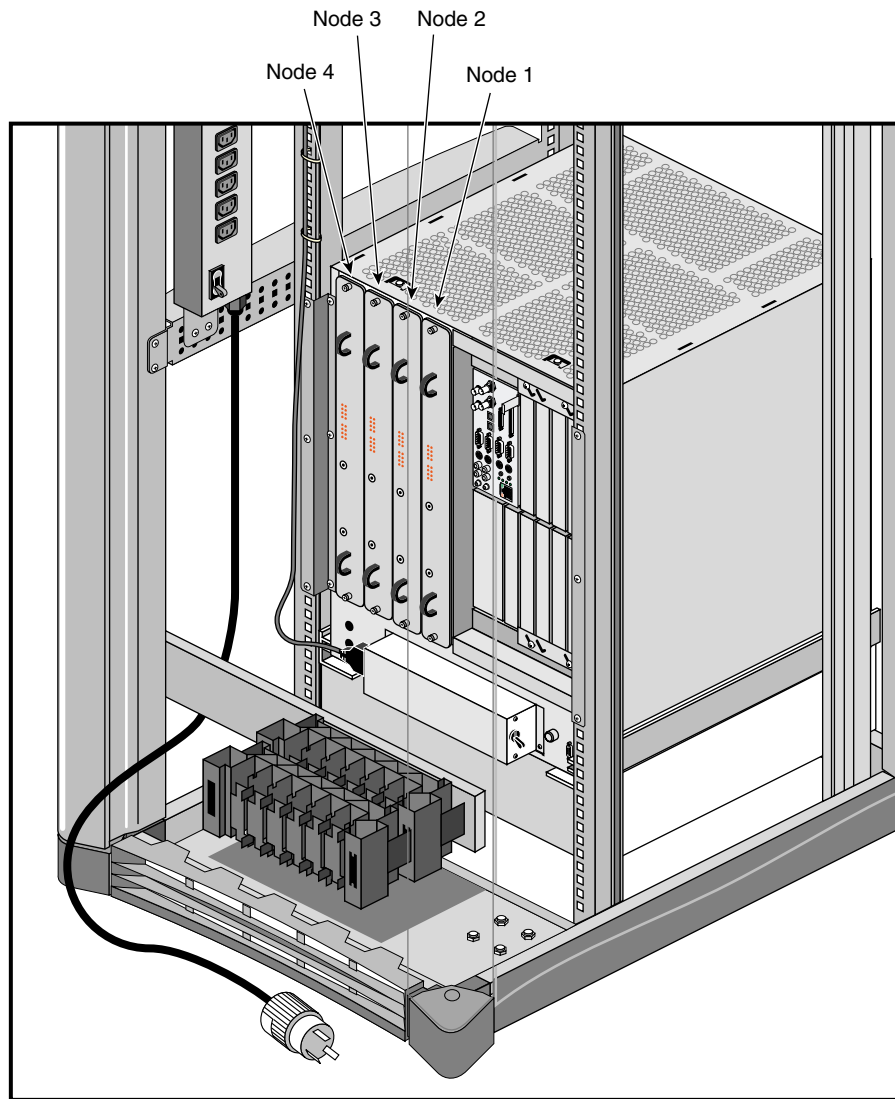
**Figure 2-7** Graphics BaseIO Panel (IO6G)

**Table 2-3** Graphics Rack BaseIO Panel Connectors

Connector Type	Connector Description	Connector Function
BNC 75 ohm jack	Digital audio out (DO)	Audio output to digital recorder
BNC 75 ohm jack	Digital audio in (DI)	Input to deskside from digital audio device
BNC 75 ohm jack	Video sync loopthrough	Video sync in/loopthrough
BNC 75 ohm jack	Video sync loopthrough	Video sync in/loopthrough
36-pin IEEE 1284-C	Parallel port	Parallel printer signals to and from external device
68-pin SCSI single-ended	Ultra (Fast-20) or SCSI-2	Single-ended SCSI
2.5 mm tip-sleeve speaker power jack	Single +10 V jack	Powered speaker output for supplied speakers
Optical	24-bit digital stereo input	Eight-channel ADAT input
Optical	24-bit digital stereo output	Eight-channel ADAT output
9-pin sub-D (1-4)	PC-compatible male serial ports	Serial RS-232 or 422 data transfer and receipt
6-pin mini-DIN (1-2)	Mouse connectors	Support mouse signals
6-pin mini-DIN (1-2)	Keyboard connectors	Support keyboard signals
2.5 mm RCA jacks (L & R)	Audio line in	Supports analog stereo inputs
2.5 mm RCA jacks (L & R)	Audio line out	Supports analog stereo outputs
3.5 mm tip-ring-sleeve jack	Single jack input	Interrupt in
3.5 mm tip-ring-sleeve jack	Single jack output	Interrupt out
3.5 mm tip-ring-sleeve jack	Single jack audio output	Analog headphone or supplied powered speakers
3.5 mm tip-ring-sleeve jack	Single jack audio input	Analog microphone input

## Node Boards

Figure 2-8 shows the location of the IP27 Node boards in the compute module. The Node board is the main processing board in the Onyx2 rack system. An individual system compute module may have up to four Node boards. Figure 2-8 also shows the required Node board slot positions in a module. The first Node board must be installed in the rightmost slot (as you face the rear of the chassis). Additional Node boards are added sequentially from right to left.



**Figure 2-8** Node Board Positions in the Chassis

The Node board consists of these major components:

- R10000 CPU
- sixteen slots of main memory
- eight slots of optional directory memory
- one or two R10000 processors (all Node boards installed in rack systems should have two R10000s)
- one HUB ASIC

### **The R10000 Processor**

The superscalar R10000 CPU is the main processor for the Onyx2 graphics rack system. There are two R10000 CPUs on each IP27 Node board. You may hear a module or rack system referred to as an “8P” or “16P” system. The *P* stands for R10000 processor. An 8P system has eight R10000 processors (four Node boards).

### **Main Memory**

The Node boards in the Onyx2 use SDRAMs mounted on dual-inline memory modules (DIMMs) for main memory. An IP27 Node board can have from 64 MB to 4 GB of main memory. Memory upgrades are available in 64, 128, and 512 MB increments.

### **HUB ASIC**

The HUB on the Node board is the primary communication link between the R10000 processor, the I/O subsystem, the main memory, and the CrayLink Interconnect. The HUB also interfaces with directory memory, which is responsible for maintaining cache coherence.

### **The Node Board Status LEDs**

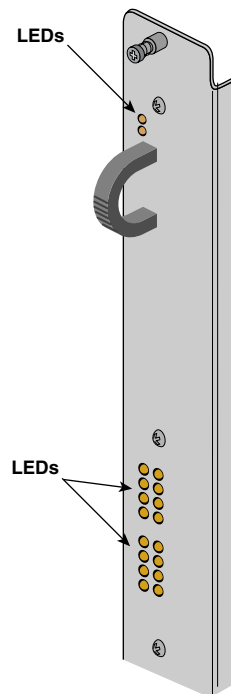
Figure 2-9 shows the outer panel on the Node board. The 18 LEDs provide status information for the individual boards. Two red LEDs are located near the top of the board and a set of 16 yellow ones are located near the middle of the board.



The two LEDs near the top of the board should light only when there is a voltage inconsistency or problem on the Node board. If these LEDs light up frequently, the board may need service. If all the top LEDs on all the Node boards in the system light up, it indicates a system wide power problem. In this case, call your service representative for assistance.

The LEDs grouped near the middle of the board are divided into two vertical sets of eight LEDs (16 total). Each vertical set of eight LEDs represents one of the R10000 microprocessors installed on the Node board. When only one R10000 is installed, you can expect to see LED activity on only one vertical set of LEDs.

As a general rule, the bottom LEDs should always show some activity while the system is powered on. The bottom LEDs serve as a kind of “heartbeat” that indicates when an R10000 is alive, even if the system is not generally active. The other seven LEDs light up as the processes that the R10000 runs increase. The more the R10000 is active, the more amber LED activity you see on the Node board.



**Figure 2-9** Node Board LEDs

## Graphics Rack System Controllers

There are two types of System Controllers for the Onyx2 rack systems—a single module System Controller (MSC) and a rack-mounted multimodule System Controller (MMSC) with a color display interface panel. The MSC does not have the same functional abilities as the MMSC. For more detailed information on operating the System Controllers, see Chapter 6, “Using the System Controllers.”

### Module System Controller and Display

The MSC and its LED display provide environmental and status monitoring for an individual compute module. Each compute and graphics module in a graphics rack system reports its information to the “multimodule” controller (also known as the MMSC).

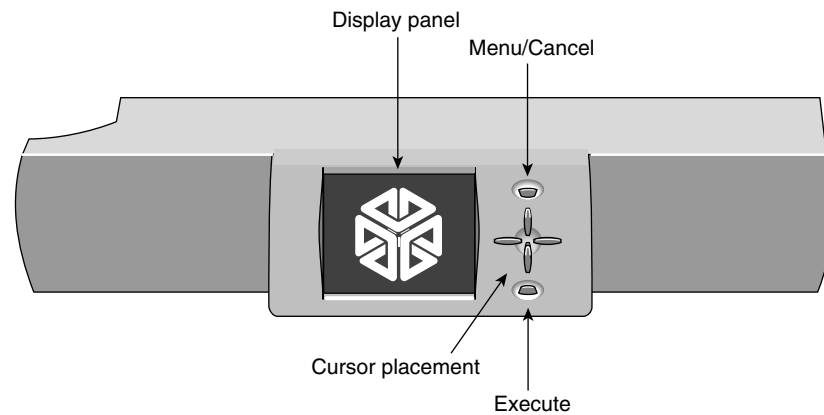
### Multimodule Controller and Display

The multimodule controller (MMSC) display (see Figure 2-10) is the single-point administration interface for the rackmount configuration. The individual module controllers are tied to the multimodule controller through a serial connection from the module to the multimodule controller board in the rack.

The MMSC color screen display interface and MMSC logic unit are two separate components.

There is only one MMSC display interface per rack system configuration. It acts as the single point of administration for all compute modules in the rack configuration. In addition, in a multirack configuration, the rack with the MMSC and display should always be placed in the leftmost position.

**Caution:** The MMSC front panel display provides a convenient method to power on, shut down, reset, and issue a nonmaskable interrupt (NMI) to the *entire* rack configuration. Use extreme care when issuing these commands from the display. Make sure that all affected users are notified before a system wide command is executed.



**Figure 2-10** MMSC Interface and Display Panel

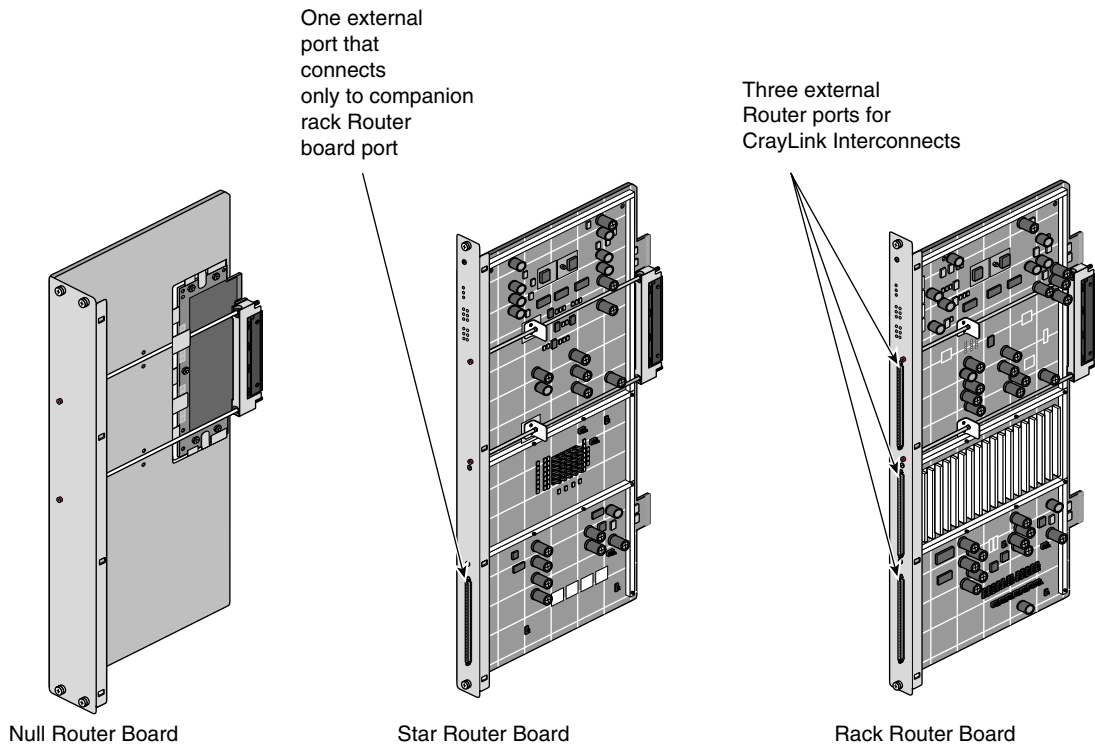
## Router Boards

The Router boards (see Figure 2-11) are multiported, bidirectional data packet controllers that can transport up to 800 MBps per port (in each direction). Each compute module can have one, two, or no Router boards (depending on the number of Node boards that are present). The Router interfaces with the HUB ASIC on Node boards and allows the R10000 processors on one Node board to directly access the main memory located on another Node board. There are three types of Router boards that can be used in the Onyx2 rack:

- Null Router
- Star Router
- Rack Router

If a compute module has only one Node board, no Router is required. A Router board is required only when there are two or more Node boards.

**Note:** The Null and Star Router boards are primarily used in deskside systems. The deskside is equivalent in size to an individual compute module in a rackmount system.



**Figure 2-11** Types of Router Boards

### **Null Router Board**

The Null router provides a low-cost method to connect two Node boards in a module. The Null Router board *cannot* be used for CrayLink Interconnect linking, and it does not have any external router connectors. The Null router board is generally used in deskside systems with only one or two Node boards.

### Star Router Board

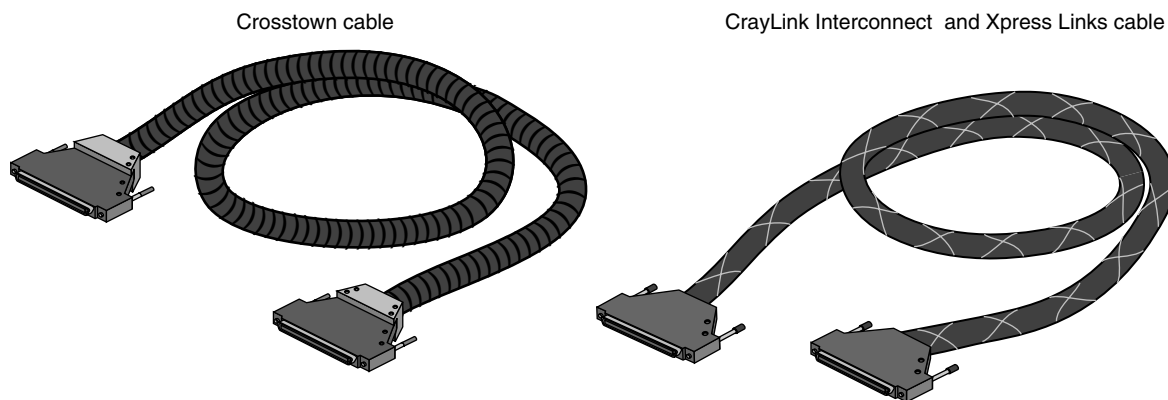
The Star Router is always paired with a Rack Router board for proper operation. This cost-effective router board provides connections with all the Node boards in a module but cannot be used for CrayLink Interconnect linking. The Star Router has one external connector which connects to a port on the companion CrayLink Interconnect router board through a jumper. The Star Router board is generally used in a single-rack Onyx2 graphics system that uses three or four Node boards and does not require connection to additional compute modules.

### Rack Router

The Rack Router boards provide CrayLink Interconnection in a multirack Onyx2 system that uses more than one compute module. This Router board can support configurations with up to 64 processors. The Rack Router has six ports that route data at up to 800 MBps (per port). Three of the ports connect internally. The fourth, fifth, and sixth ports can connect to external router ports on other compute modules.

### Module-to-Module Interconnects

The CrayLink Interconnect and the Xpress Links are the cabled interface that runs between rack Router boards (see Figure 2-12). These cables provide a high speed (800 MBps), scalable interconnection between different modules. These cables also supply physical link redundancy so that if a link fails, another link can take its place.



**Figure 2-12** Crosstown and CrayLink Interconnect Cables

The crosstown cables connect each graphics module's KTOWN interface board directly with the compute module. Each pipe in the graphics module must have its own crosstown cable connection coming from a crosstown XIO board in the compute module. The KTOWN board in the graphics module sits directly between the two board sets in the graphics module.

### Cautionary Guidelines

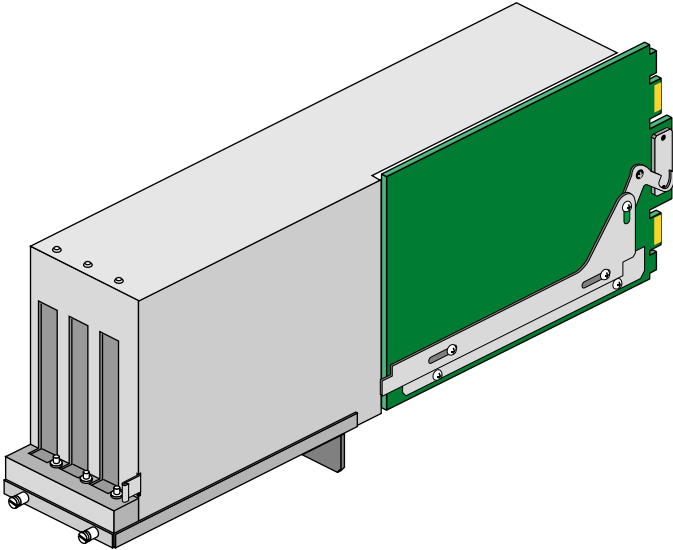
You generally should not handle these sensitive linking cables; they are very delicate. Observe the following guidelines if you need to move these cables:

- Avoid bending the cables tighter than a 1.25-inch radius.
- Avoid stepping on the cables.
- Avoid "hot plugging" in or removing cables while the system is up and running. This can *hang* or *crash* the entire graphics rack system.

**Caution:** Additional Router and crosstown cable connections should be performed only by Silicon Graphics-certified personnel.

## Optional PCI Board Carrier

Each compute module in an Onyx2 graphics rack system can support an optional peripheral connector interface (PCI) carrier assembly. The PCI assembly can house up to three third-party PCI boards (see Figure 2-13). Two of the PCI boards can be full-size boards. The third PCI slot accepts only half-size boards. The PCI carrier assembly provides up to 75 watts of power.



**Figure 2-13** Optional PCI Board Carrier Assembly

This chapter identified and explained the major components that make up a graphics rack system. For information on graphic rack configurations and getting started using your system, go on to the next chapters.





---

## System Configurations, Connections, and Cabling

The first part of this chapter describes the single rack and multirack system configurations. All configurations contain the following major hardware components:

- Node boards with R10000 (T5) processors and 64 MB to 4 GB of main memory
- a Router board
- a graphics Base I/O board that provides the system I/O ports such as serial, Ethernet, and SCSI interfaces, and analog or digital audio connections
- InfiniteReality board sets (graphics pipes)
- an Origin Vault drive box

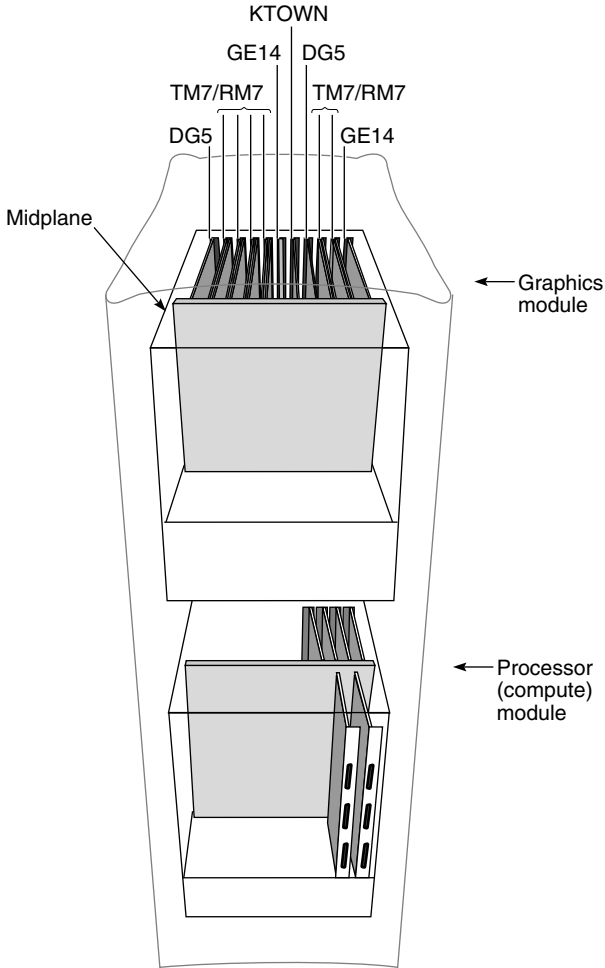
### Rackmount Configurations

The Onyx2 graphics rack (see Figure 3-1) is a standard 19-inch rack system that comes with a multimodule System Controller (MMSC) and provides cable management hardware for CrayLink Interconnect and XIO cables.

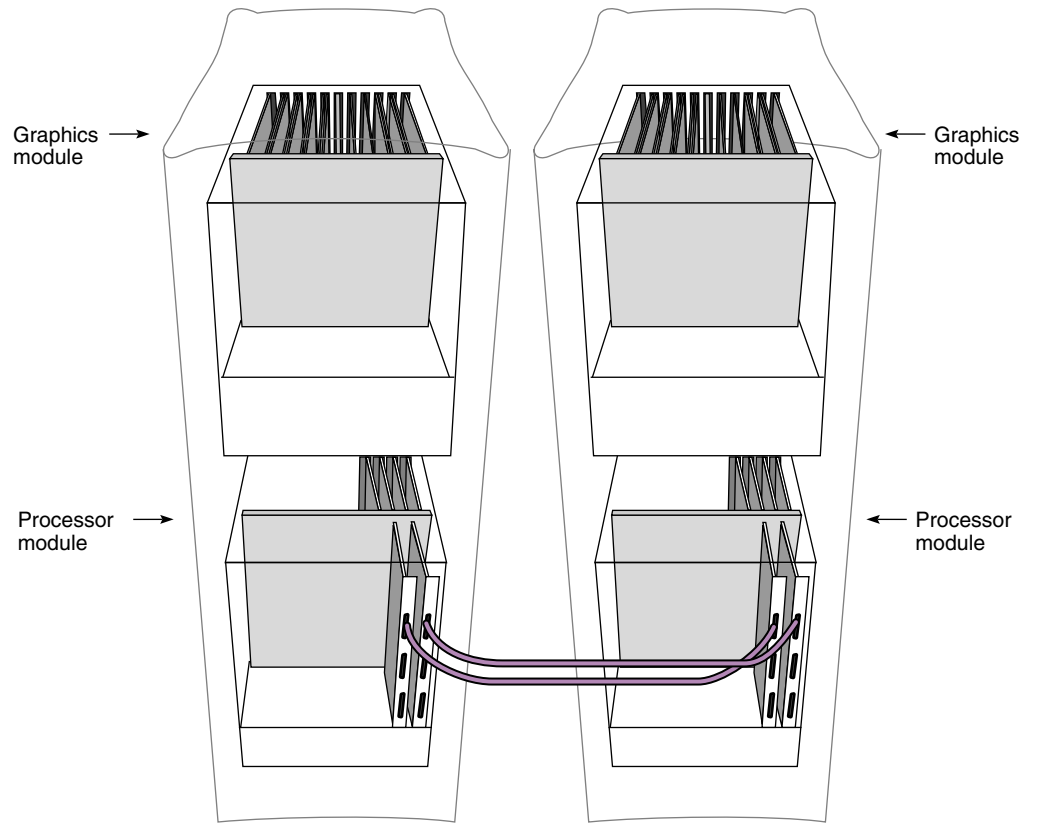
**Note:** Multirack systems can hold additional compute or graphics modules, and individual hardware components can be added to suit growing graphics, computational, and I/O requirements.

The Onyx2 dual multirack configurations are shown in Figure 3-2 and Figure 3-3. These configurations can have from 4 to 24 processors and up to four graphics pipes. The Onyx2 triple multirack configuration (Reality Monster) is shown in Figure 3-4. This configuration can have from 8 to 16 processors and up to eight graphics pipes. (Each RealityMonster graphics pipe requires one node board).

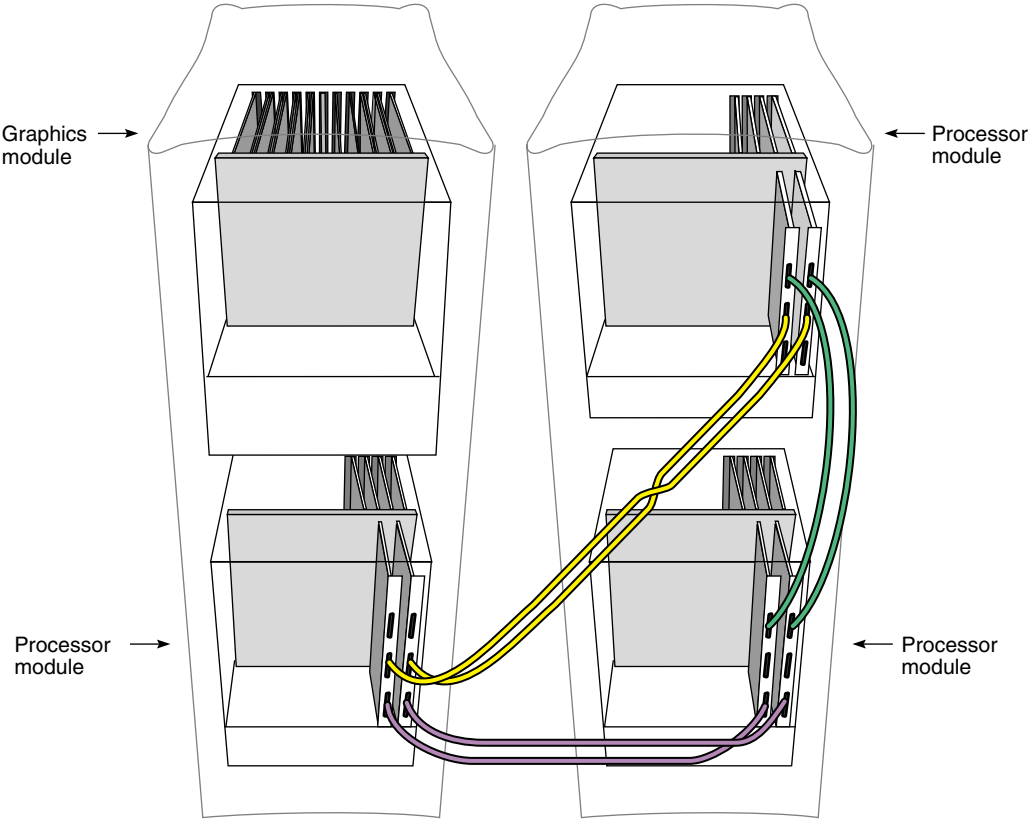
**Note:** A maximum configured RealityMonster system requires an ethernet hub to connect the three multimodule System Controllers (MMSCs).



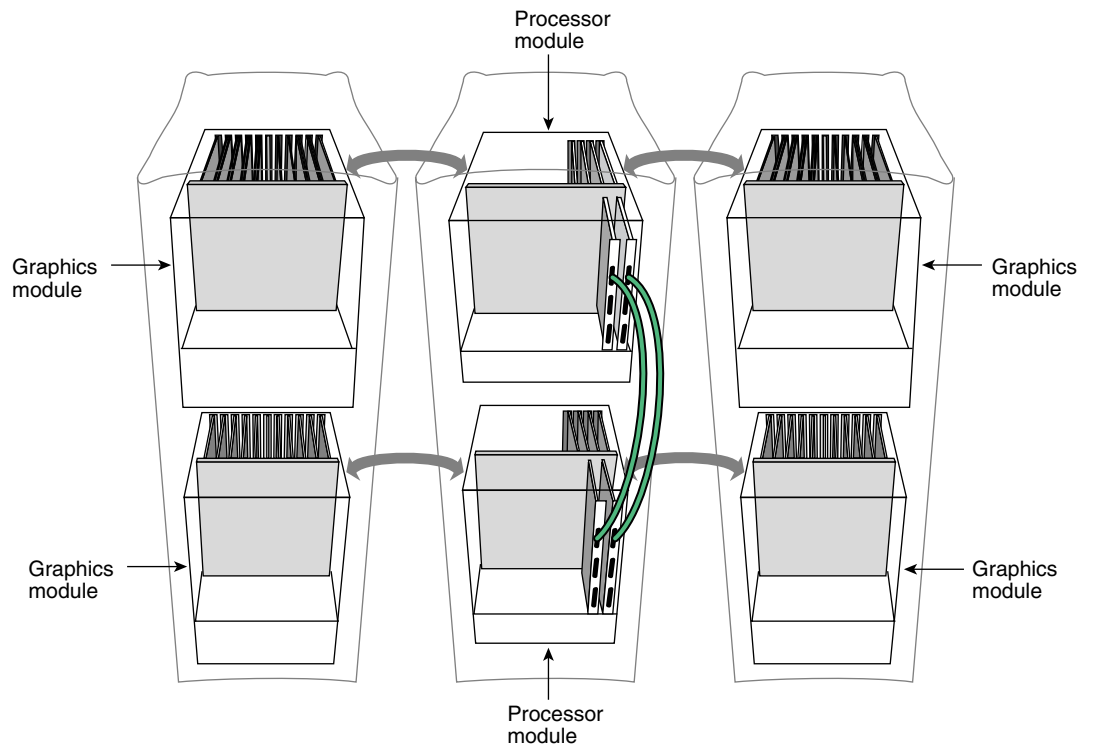
**Figure 3-1** Onyx2 Single-Rack System (8P and 2 Graphics Pipes)



**Figure 3-2** Onyx2 Multitrack System (16P and 4 Graphics Pipes)



**Figure 3-3** Onyx2 Multitrack System (24P and 2 Graphics Pipes)



**Figure 3-4** Onyx2 RealityMonster Multirack System (16P and 8 Graphics Pipes)

## Graphics Interface Panels

This section describes the DG5 main display board options for the Onyx2 desktside graphics systems. It also describes the VIO5H video option connector panel board, which mounts on the DG5-8 and outputs five high-resolution video channels.

Additionally, this section describes the Serial Digital Video Output from Graphics (GVO) option, which provides additional CCIR601 output on two BNCs.

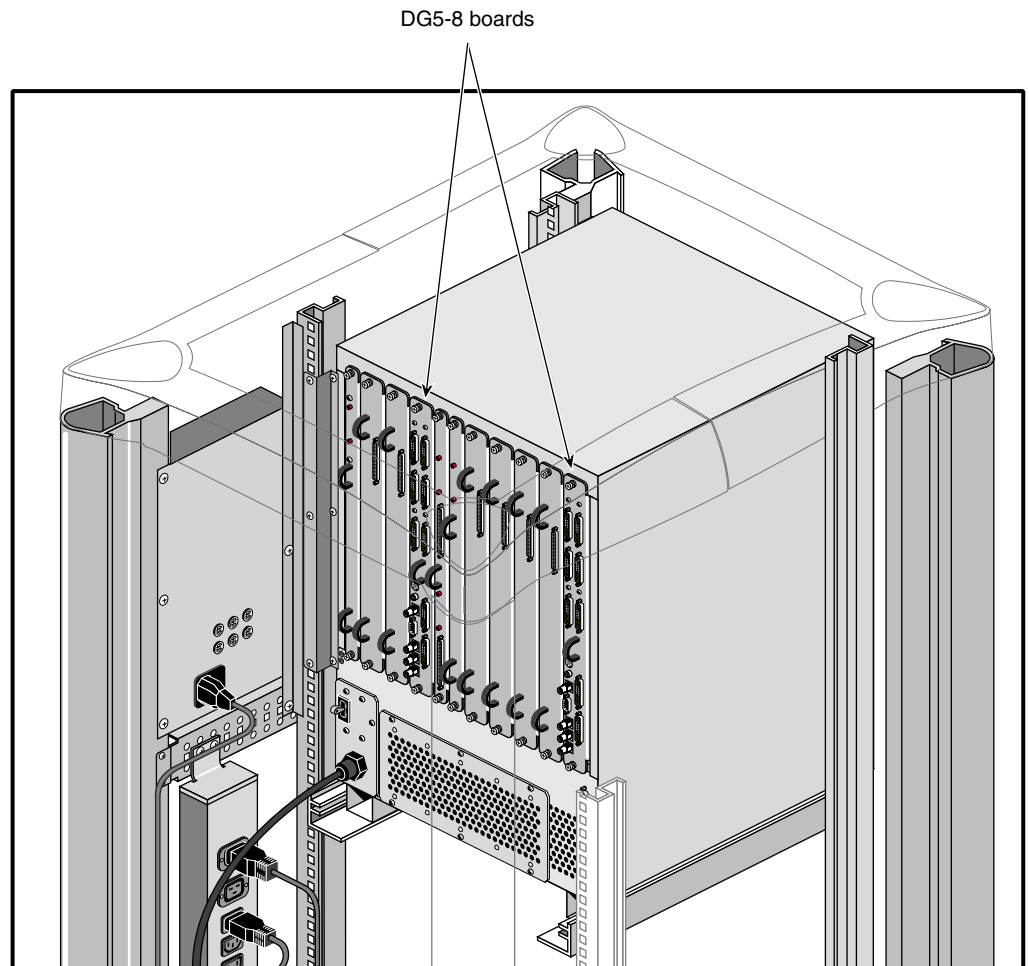
Table 3-1 summarizes DG5 configurations.

**Table 3-1** DG5 Configurations

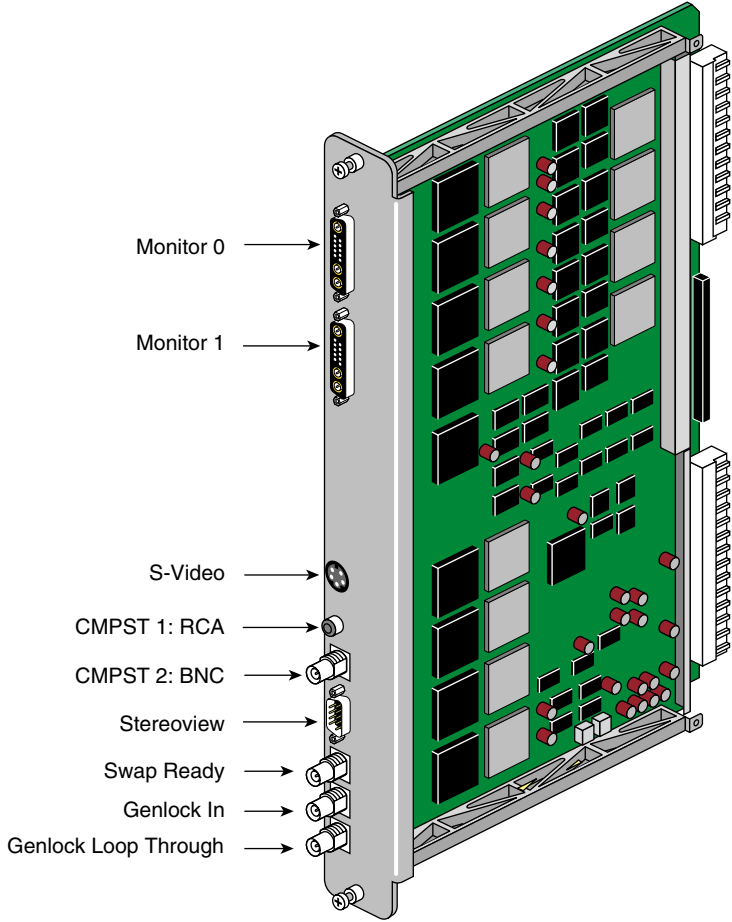
DG5	VIO5H	GVO	Description
DG5-2	Not required	Not required	Basic configuration: two high-resolution video outputs
DG5-8	Required	Not required	Eight high-resolution video outputs
DG5-2	Not required	Required	Two high-resolution video outputs with two CCIR601 outputs

Figure 3-5 shows the location of two optional DG5-8 boards with the VIO5H option daughterboard installed in the graphics module.

Note that the DG5-8 option always requires the VIO5H daughterboard. The DG5 board always goes in the rightmost graphics board slot in each board set (pipe) in the Onyx2 graphics module. Figure 3-6 shows the DG5 board without options (DG5-2).



**Figure 3-5** DG5-8 Board Locations



**Figure 3-6** DG5-2 Graphics Panel Connections (Without Options)



## DG5 Board Operation

The display generator subsystem requests and receives digital frame buffer pixel data from the RM/TM board. The DG5 board processes the pixel data and streams it onto the video packet bus. The DG5 board also handles all pixel clocking and genlocking and cursor display functions, and performs the role of the functional manager.

From the packet bus, processed video can be sent to one of the video output channels, or to the NTSC or PAL encoder (VTR channel). The video output controller supplies data to a 3-DAC array that feeds the analog RGB signals out. NTSC or PAL circuitry signals come from the VOC through encoder and field buffer RAMs.

The default monitor resolution supported by the InfiniteReality SuperWide monitor is 1920 x 1200 at 66Hz. The maximum output bandwidth is about 300 Mpix/sec. With two monitors, each 1920 x 1200 at 66 Hz, speed is about 188 Mpix/sec. If you connect more than two monitors, you must use a combination of lower and higher resolution monitors that is within the limit of 300 Mpix/sec.

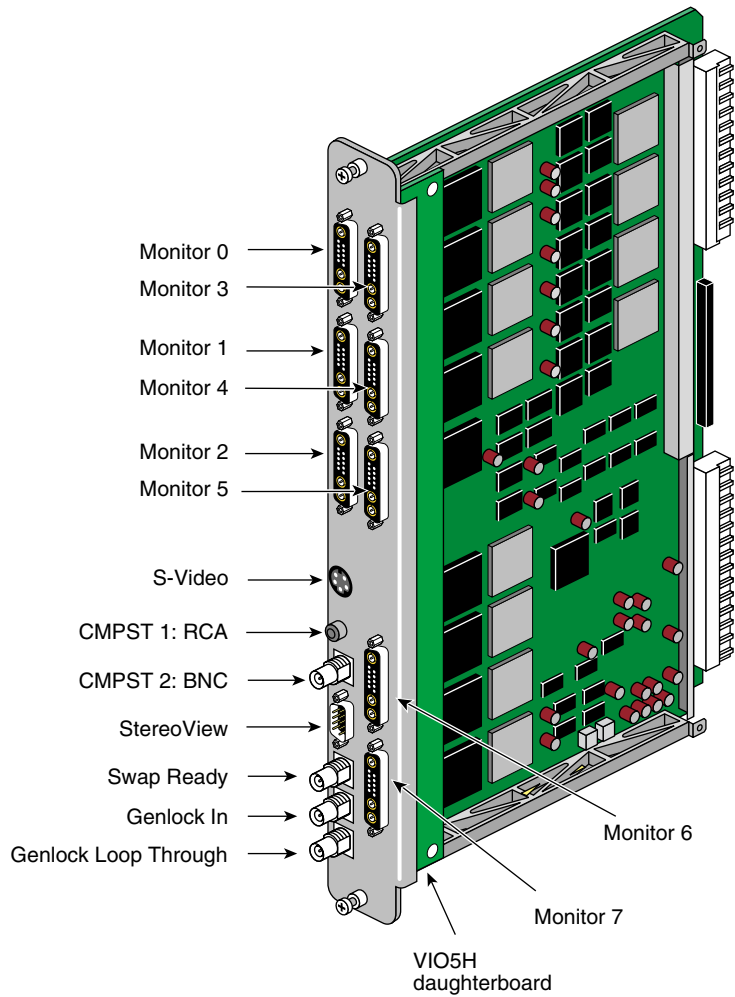
Table 3-2 summarizes DG5-8/VIO5H connectors.

**Table 3-2** DG5-8/VIO5H Connectors

Label	Type	Function
Monitor 0 through 7	13W3	Variable high-resolution monitor outputs
S-Video	4-pin mini-DIN	Interface to SVHS VCR or monitor
CMPST 1	RCA jack; BNC	Interface to composite monitor or VCR
StereoView™	9-pin sub-D	Interface to StereoView device
Genlock In	BNC	Interface to video mixer
Genlock Out	BNC	Loophrough connection
Swap Ready	BNC	Interface to other graphics systems

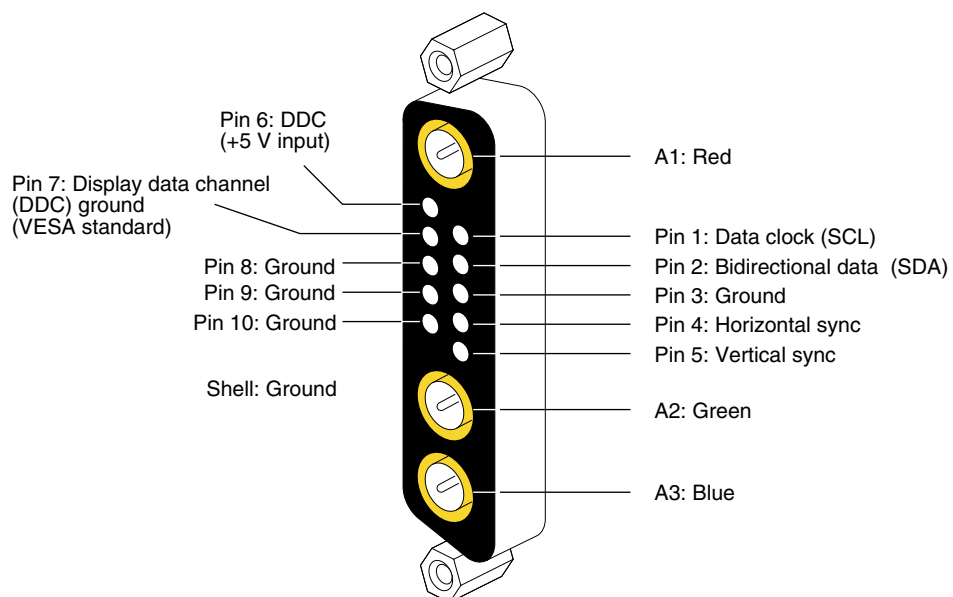
### Connectors on the DG5 Option Board

Figure 3-7 shows connectors on the panel for the DG5-8 option board with the VIO5H daughter board.



**Figure 3-7** DG5-8 Board With Optional VIO5H

Figure 3-8 shows the 13W3 pinouts for the monitor connectors on the DG5 I/O panel; each 13W3 uses the same pinout pattern.



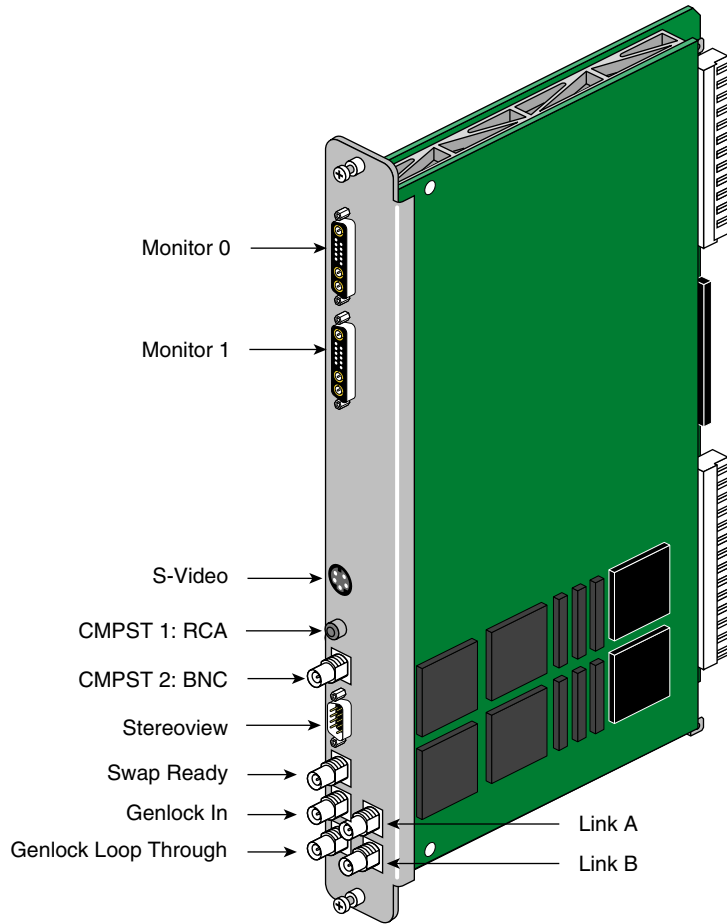
**Figure 3-8** DG5/VIO5H 13W3 Connector Pinout

In the A1, A2, and A3 connectors, the center conductor carries the video signals. The outer conductors of the A1, A2, and A3 connectors are their video returns, which are tied to the monitor's grounded chassis.

### Connectors on the Optional GVO Daughterboard

The graphics-to-video option (GVO) daughterboard comes assembled with the DG5 and is designed to provide direct output from graphics to video in real time.

The GVO daughterboard has two CCIR601 connectors implemented as BNCs. Figure 3-9 shows connectors on the panel for the DG5-8 board with optional GVO daughterboard combination.

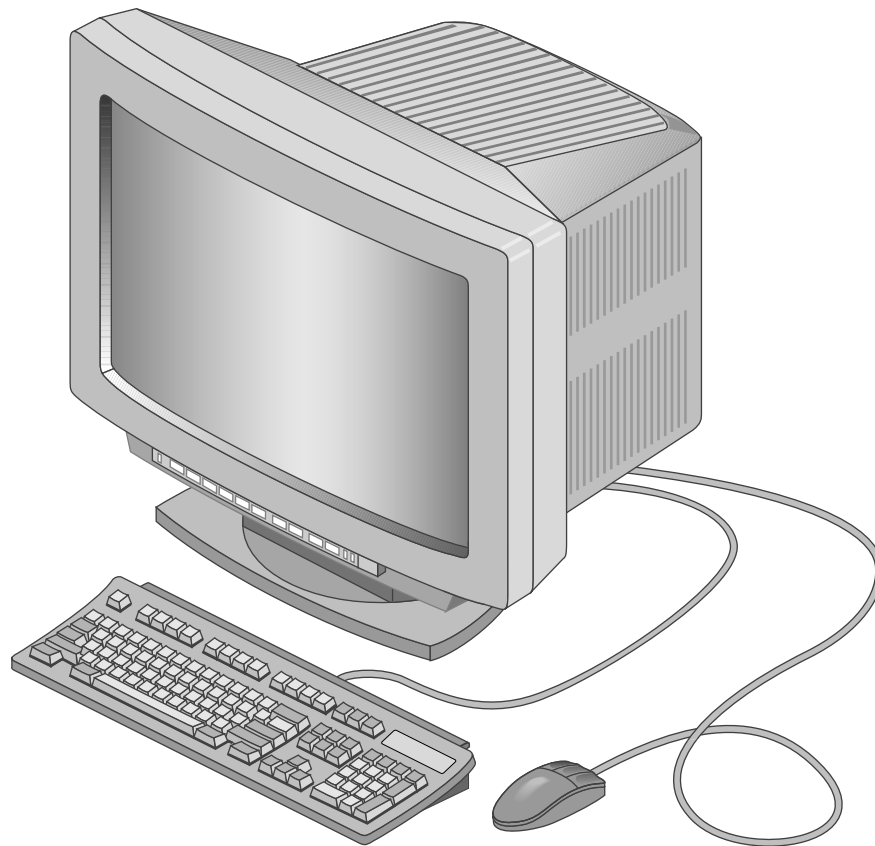


**Figure 3-9** DG5 With Optional GVO Connectors

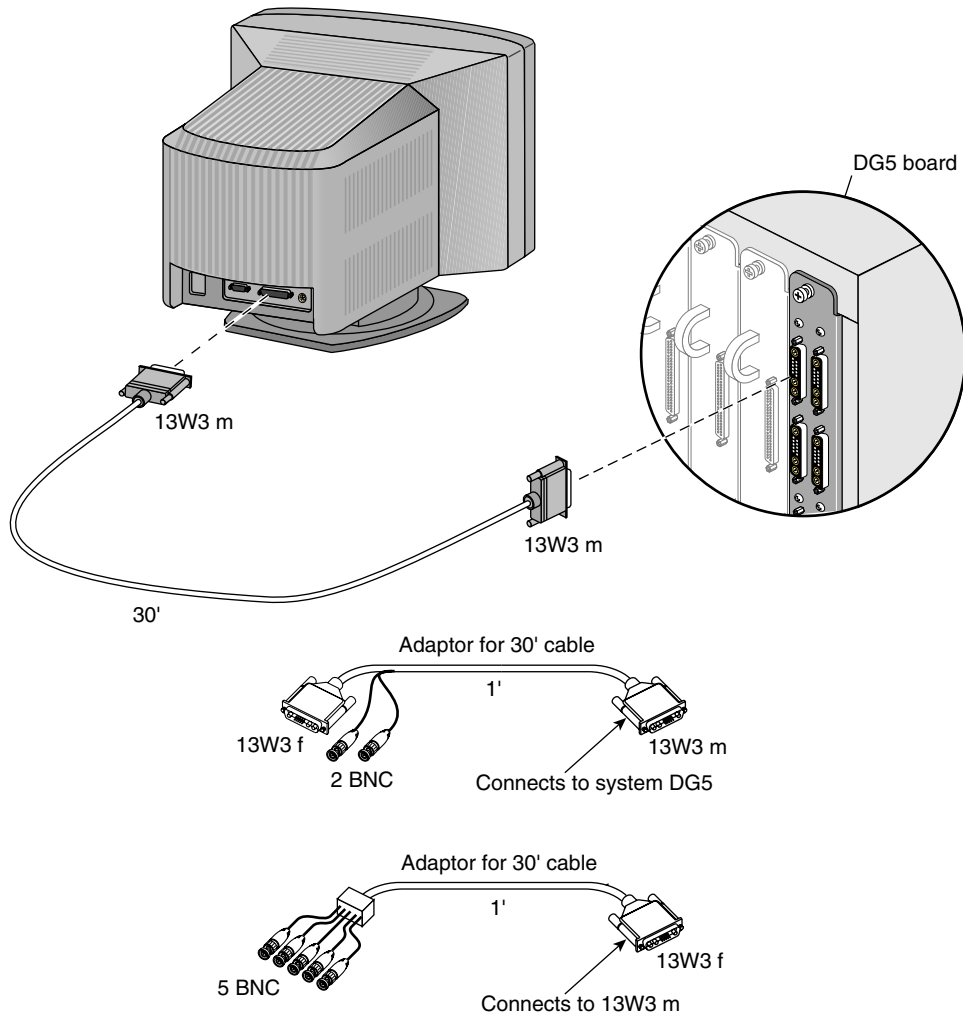
## Cabling Options

Three cable options are offered for the DG5:

- 13W3-13W3: for use with the Silicon Graphics 24-inch SuperWide monitor and other compatible monitors (see Figure 3-10)
- 13W3-five BNCs: separate connectors for R, G, B, horizontal sync, and vertical sync for monitors that require these separate connectors (see Figure 3-11)
- 13W3-13W3HV: two separate BNC connectors for horizontal and vertical sync (for example, for synchronizing video out “genlocking”)



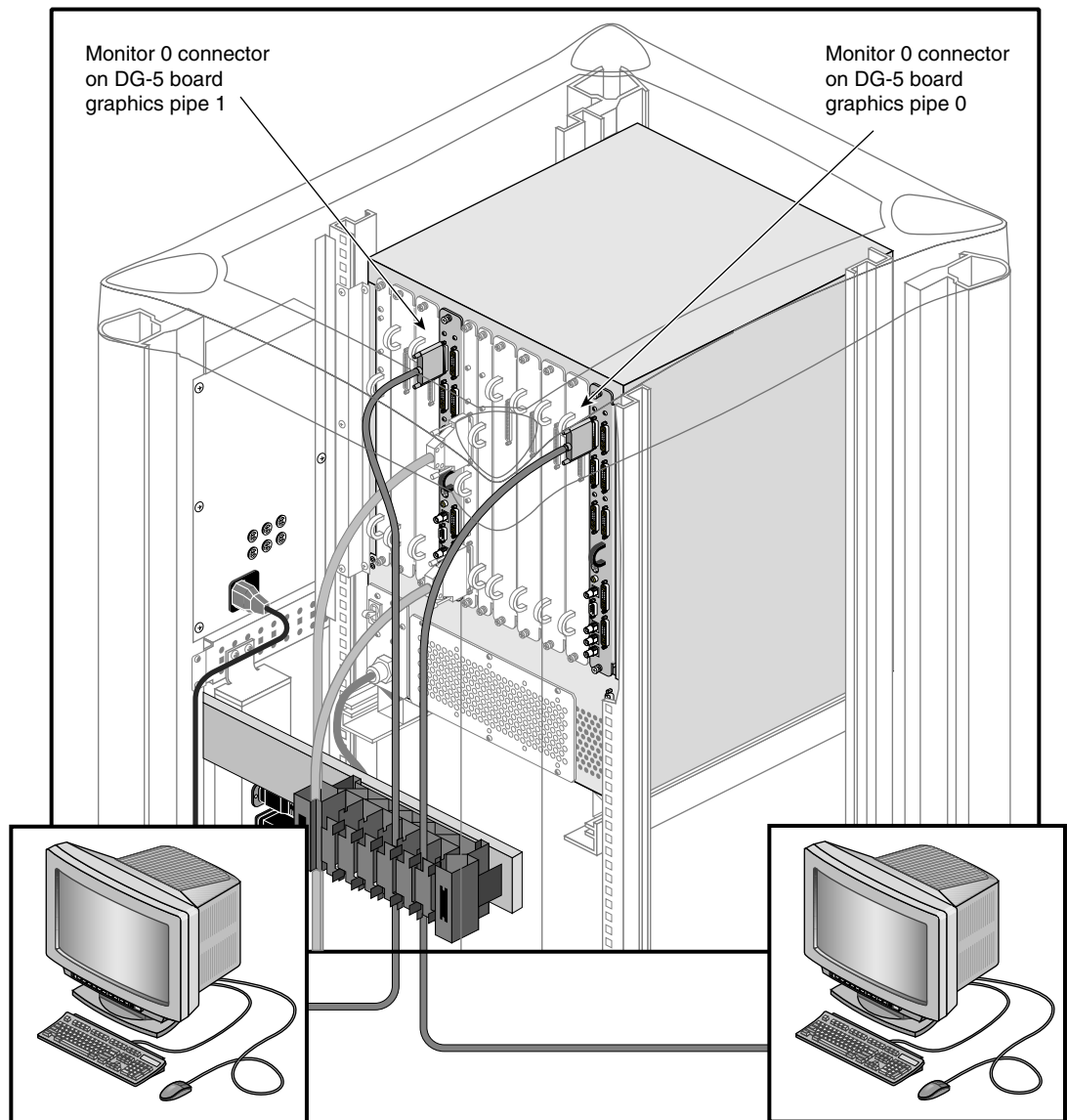
**Figure 3-10** SuperWide Monitor



**Figure 3-11** 13W3 Monitor Cable and Adapters

Each cable ordered connects to a 13W3 port on one of the DG5 boards in the graphics module.

Figure 3-12 shows a connection example with two monitors attached to separate graphics pipes on the Onyx2 rack's graphics module.

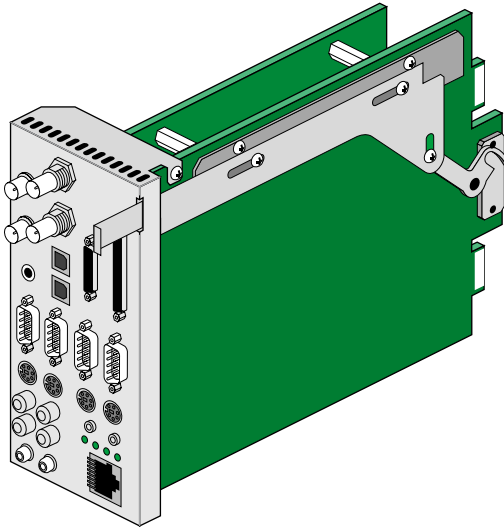


**Figure 3-12** Cable to Monitor Connection Example

## The Graphics BaseIO Interface Panel

The graphics BaseIO assembly (IO6G) is a graphics-oriented set of interface connectors that comes standard with each Onyx2 rack system. The connectors on the BaseIO include support for Ethernet, two keyboards, analog and digital audio, serial and parallel connectors, and others. The following sections provide location and pinout information on these connectors.

Figure 3-13 shows the connectors and the graphics BaseIO assembly.



**Figure 3-13** BaseIO (IO6G) Assembly and Connectors



## 10/100 BaseT Ethernet Port

A single 10/100 BaseT Ethernet connection is provided on the graphics BaseIO panel. Figure 3-14 shows the location and pinouts of the connector.

You can add 10/100 BaseT Ethernet connectors with an optional XIO board.

There are two LEDs on the RJ-45 Ethernet. The top (green) LED lights only when the system is transmitting. The bottom (yellow) LED lights whenever a packet is on the wire. This includes packets not destined for your system.

Just above the RJ-45 Ethernet connector is a set of four LEDs. They have the following functions:

- The yellow LED on the far left (LED 1) lights to indicate SCSI activity on the BaseIO single-ended SCSI connector.
- The green LED (LED 2) lights to indicate 100-Mbps packet activity.
- The yellow LED on the right (LED 3) indicates when the Ethernet is operating at full duplex rates of transfer or receive.
- The rightmost green LED (LED 4) shows the Ethernet link test. It lights when link state is valid.

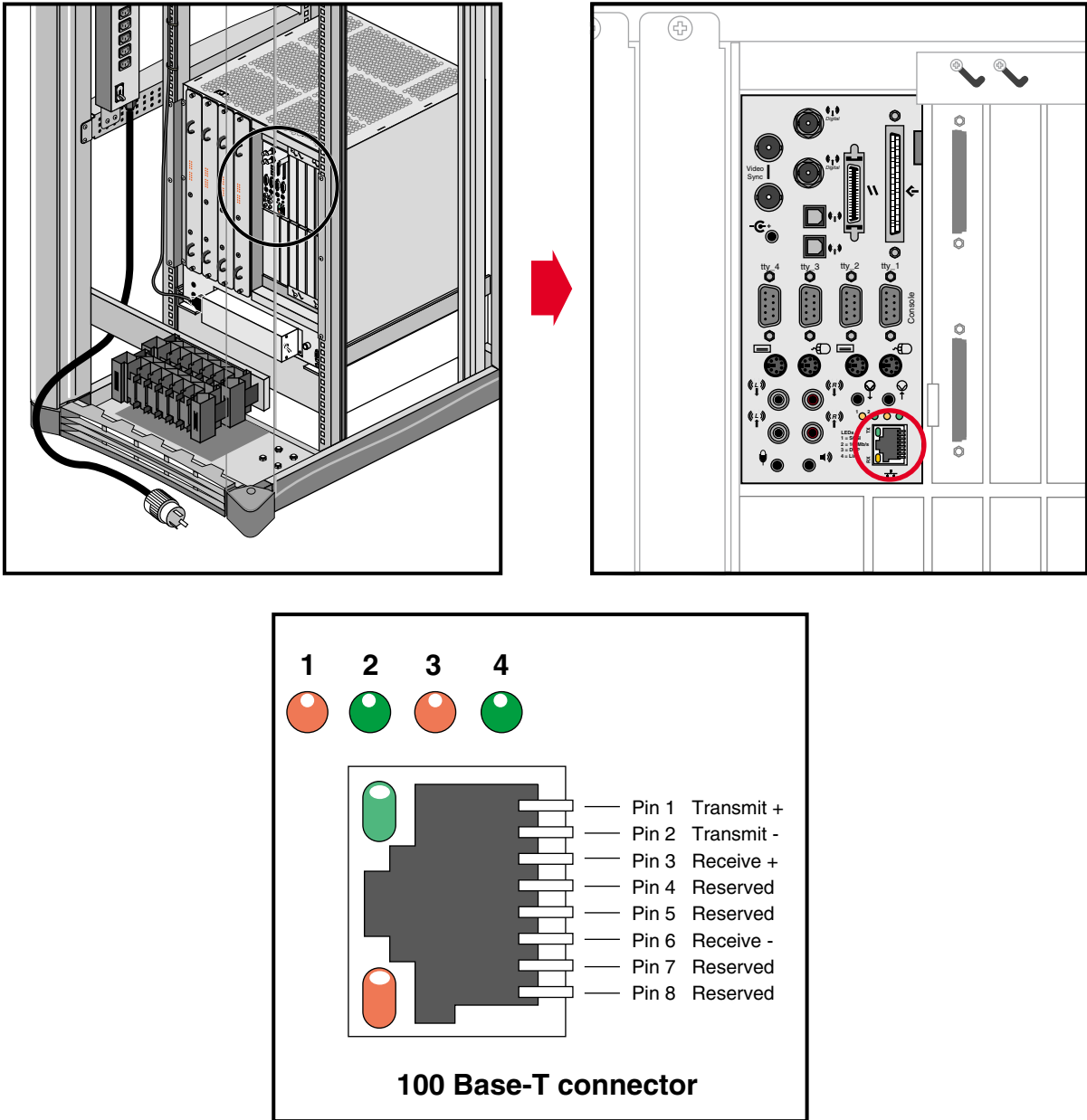


Figure 3-14 10/100 Base-T Ethernet Connector

Table 3-3 shows the cable pinout assignments for the Ethernet 10/100 Base-T Ethernet port.

**Table 3-3** Ethernet 10/100 Base-T Ethernet Port Pin Assignments

<b>Pin</b>	<b>Assignment</b>
1	TRANSMIT+
2	TRANSMIT-
3	RECEIVE+
4	(Reserved)
5	(Reserved)
6	RECEIVE-
7	(Reserved)
8	(Reserved)

## Parallel Port Connector

The BaseIO board supports one IEEE 1284-C 36-pin parallel port connector. The location of this connector is shown in Figure 3-15. Pinouts for the parallel port connector are listed in Table 3-4.

Suitable cables for use with this port should be marked "IEEE 1284-compliant." For most parallel printers, you can use a cable with an IEEE 1284-C connector at the Onyx2 end and an IEEE 1284-B connector (also known as a Centronics-style) at the printer end.

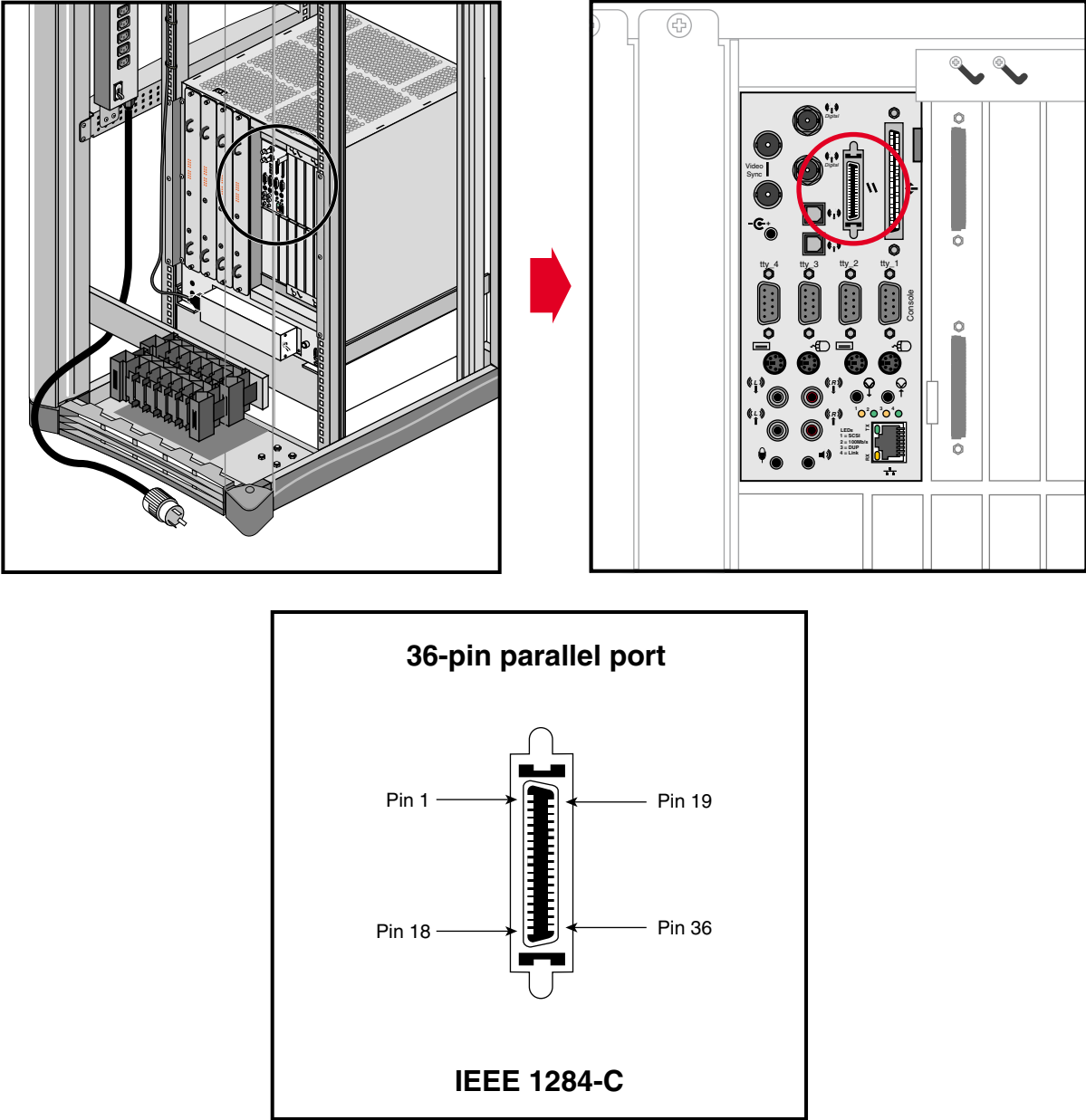


Figure 3-15 Parallel Printer Port Location

**Table 3-4** Pinouts for the 36-Pin Parallel Port Connector

Pin	Signal	Source
1	Busy	Printer
2	Select	Printer
3	nAck	Printer
4	nFault	Printer
5	PError	Printer
6	Data 1 (LSB)	Bidirectional
7	Data 2	Bidirectional
8	Data 3	Bidirectional
9	Data 4	Bidirectional
10	Data 5	Bidirectional
11	Data 6	Bidirectional
12	Data 7	Bidirectional
13	Data 8 (MSB)	Bidirectional
14	nInit	Host
15	nStrobe	Host
16	nSelectIn	Host
17	nAutoFd	Host
18	Host Logic High	N/A
19	Signal ground (Busy)	N/A
20	Signal ground (Select)	N/A
21	Signal ground (nAck)	N/A
22	Signal ground (nFault)	N/A
23	Signal ground (pError)	N/A

**Table 3-4 (continued)** Pinouts for the 36-Pin Parallel Port Connector

Pin	Signal	Source
24	Signal ground (Data 1)	N/A
25	Signal ground (Data 2)	N/A
26	Signal ground (Data 3)	N/A
27	Signal ground (Data 4)	N/A
28	Signal ground (Data 5)	N/A
29	Signal ground (Data 6)	N/A
30	Signal ground (Data 7)	N/A
31	Signal ground (Data 8)	N/A
32	Signal ground (nInit)	N/A
33	Signal ground (nStrobe)	N/A
34	Signal ground (nSelectIn)	N/A
35	Signal ground (nAutoFd)	N/A
36	Peripheral logic high	Printer

### Mouse and Keyboard Ports

Each Onyx2 graphics rack system comes with two keyboard and mouse connectors. Figure 3-16 shows the location of the connectors and their pinouts.

There are two sets of keyboard and mouse connectors on the rear of the graphics BaseIO panel provided with each Onyx2 system. If your system uses one keyboard and mouse, attach them to the primary keyboard and mouse connector ports. These primary ports are located on the right side of the BaseIO panel.

You can plug the keyboard and mouse cables directly into the BaseIO panel. However, in cases where your monitor, keyboard, and mouse are located away from the system, use the included extension cable. Each system comes with a 24-foot (7.3 m) keyboard and mouse extension cable.

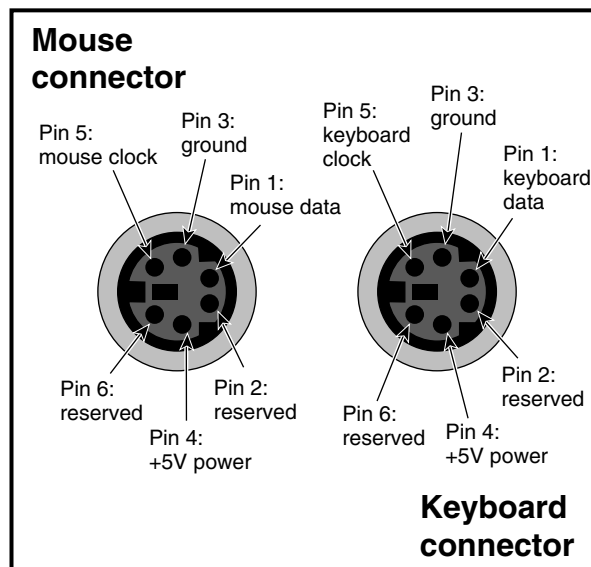
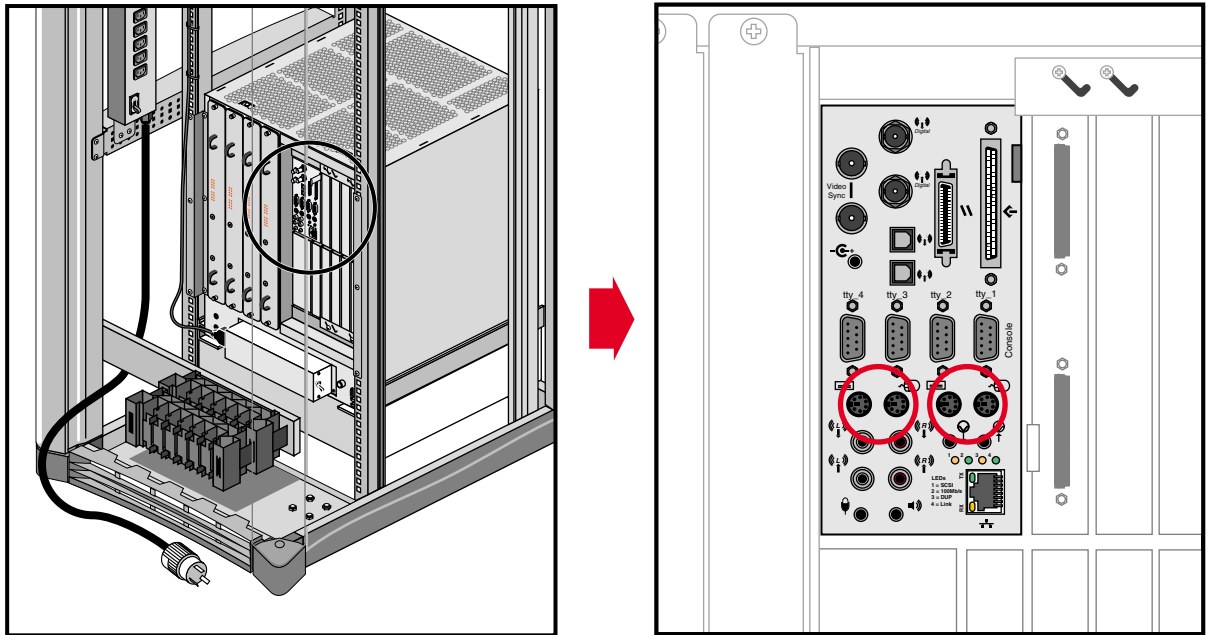


Figure 3-16 Keyboard and Mouse Locations and Pinouts

Table 3-5 shows the cable pinout assignments for the keyboard port.

**Table 3-5** Keyboard Port (6-Pin MINIDIN) Pin Assignments

Pin	Assignment
1	KEYBOARD DATA
2	(Reserved)
3	GROUND
4	KEYBOARD POWER (+5V)
5	KEYBOARD CLOCK
6	(Reserved)

Table 3-6 shows the cable pinout assignments for the mouse port.

**Table 3-6** Mouse Port (6-Pin MINIDIN) Pin Assignments

Pin	Assignment
1	MOUSE DATA
2	(Reserved)
3	GROUND
4	MOUSE POWER (+5V)
5	MOUSE CLOCK
6	(Reserved)



## Analog Stereo In and Out (RCA-Type) Ports

Table 3-7 shows the cable pinout assignments for the line level audio (RCA-type) ports.

**Table 3-7** Analog Composite Video Port Pin Assignments

Pin	Assignment
(sleeve)	GROUND
(tip)	Line level audio

You may connect audio equipment to the line level inputs and outputs using standard shielded RCA-type connectors (see Figure 3-17). For best results, always route these analog signal cables away from power cords.

The right channel is color coded red, and the left channel is white.

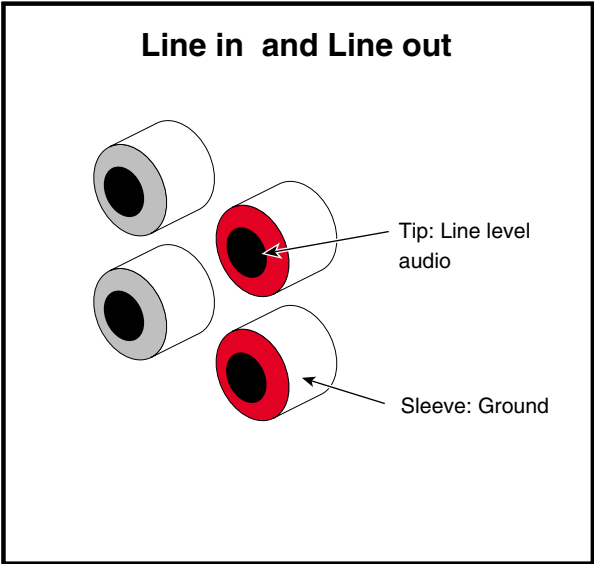
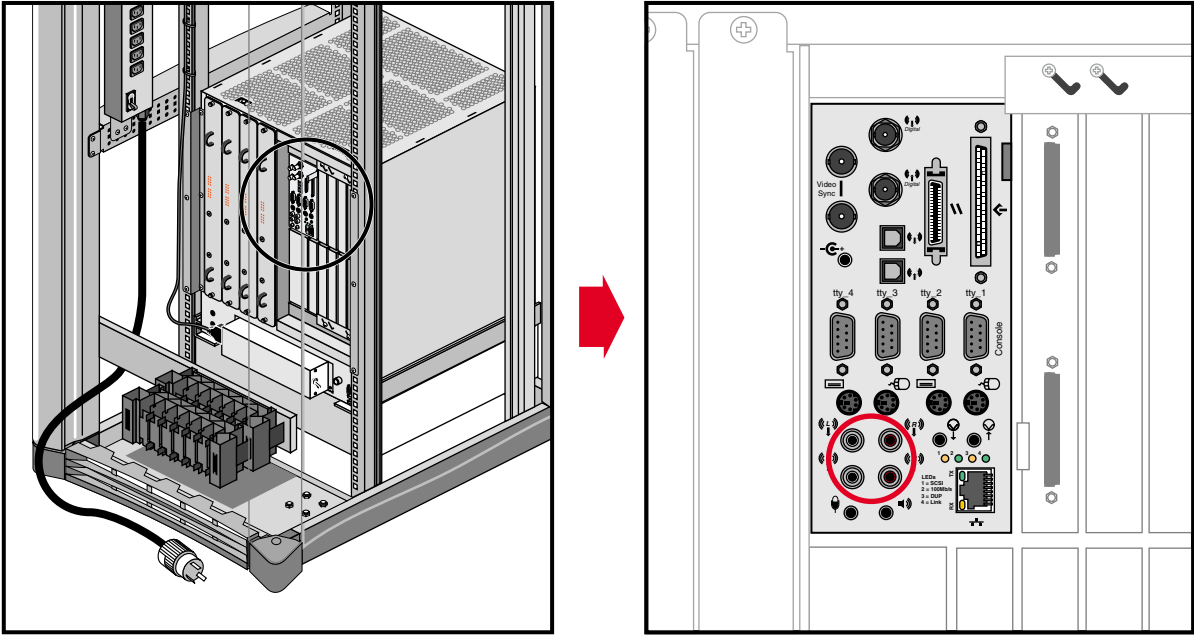


Figure 3-17 Line In and Out Stereo Ports

## Serial Connectors

The graphics BaseIO board comes with four standard 9-pin serial connectors. The connectors are all male and use a PC-compatible signal assignment. Figure 3-18 shows the connector locations and pin assignments.

The RS-232 standard recommends the use of cables no longer than 50 feet (15.2 meters). This standard should also be applied to RS-422 serial use. Longer runs introduce a greater possibility of line noise. This can affect data transmission and cause errors. For cable runs longer than 50 feet (15.2 meters), use an appropriate extender device.

**Note:** Do not run cables through areas that are electrically noisy, such as areas where large electric motors, welding apparatus, or X-ray machines operate. Bury outside wiring in a conduit, as lightning strikes can damage the system.

See Figure 3-19 for a terminal-to-serial port connection example.

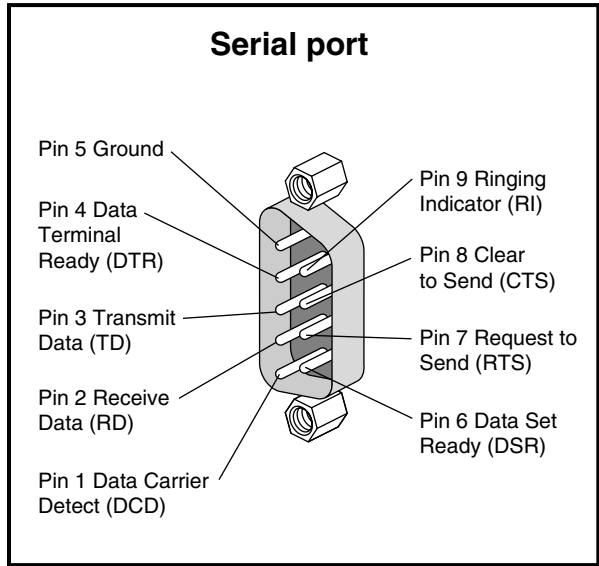
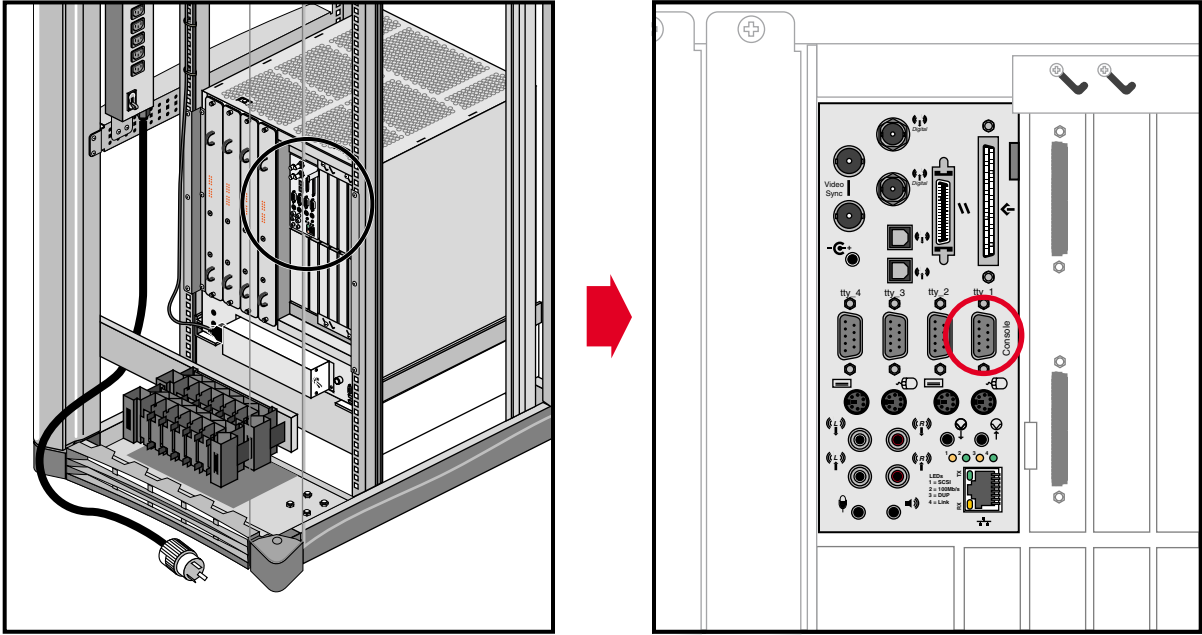
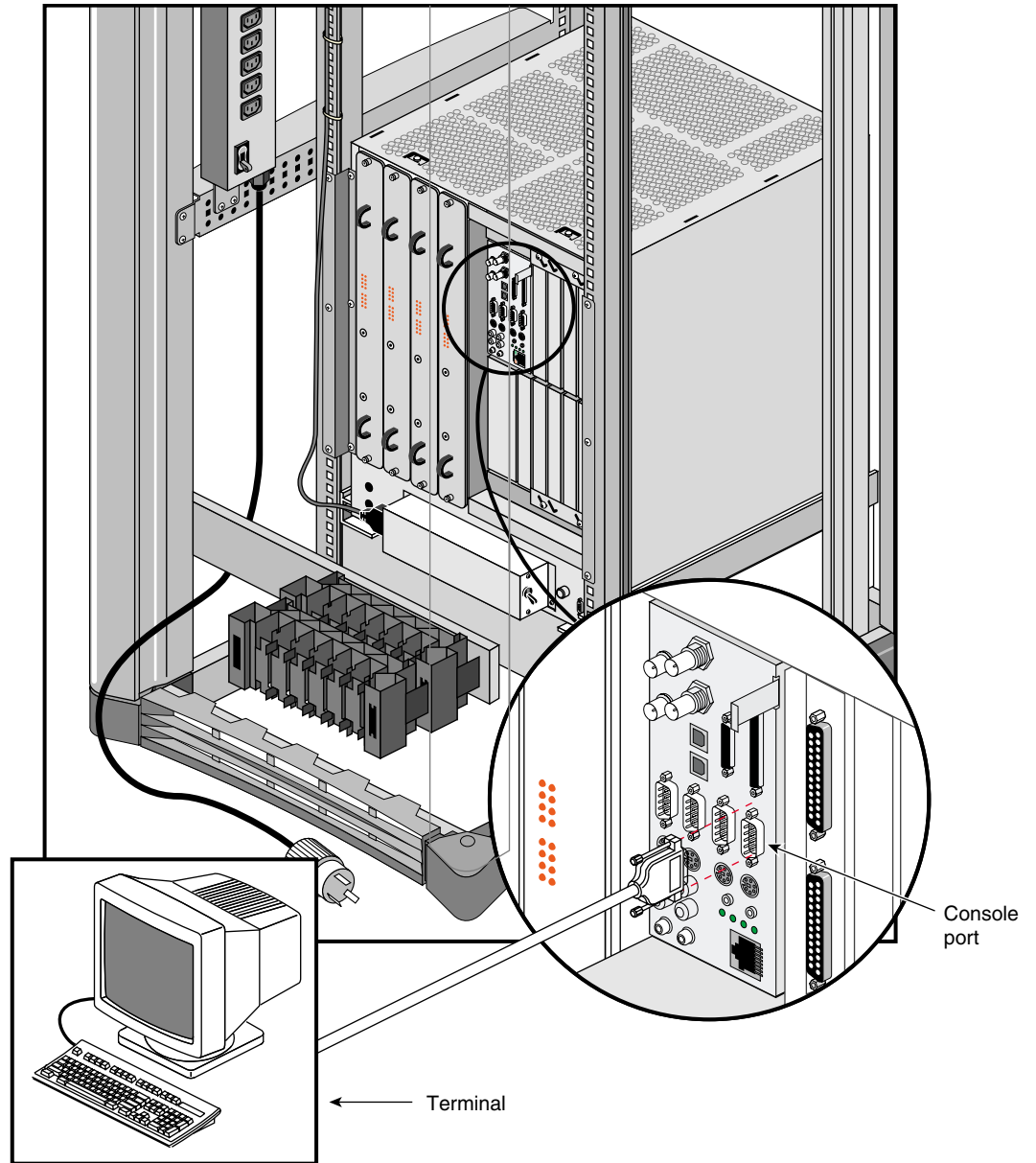


Figure 3-18 RS-232/RS-422 Serial Connectors



**Figure 3-19** Serial Port Connection Example

## Optical Digital Audio Interface Connectors

Just above serial port three are the single-jack ADAT optical connectors (see Figure 3-20). These ports can be used with multitrack digital audio recording input and output devices.

These connections support optical input and output of eight channels at up to 24 bits and up to 48 KHz sample rates.

Use standard plastic fiber interconnecting cables. You will need two cables; one for input and one for output. The Onyx2 system ships with connector cover plugs over the input and output ports. These must be removed before using the optical connectors. Retain these dust covers for use when shipping or if you discontinue ADAT use.

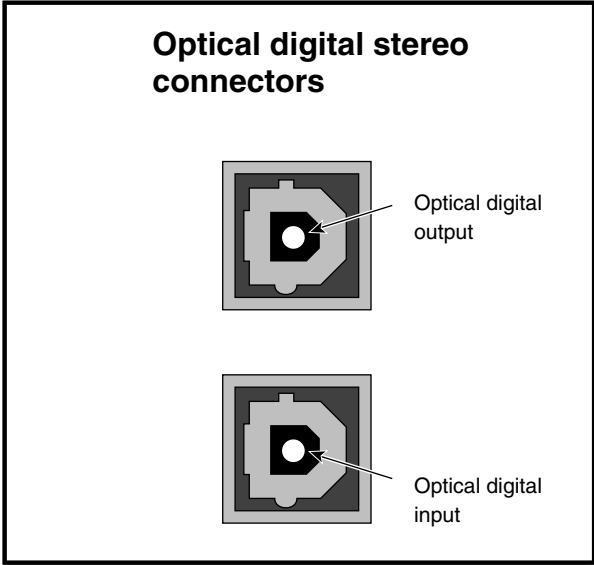
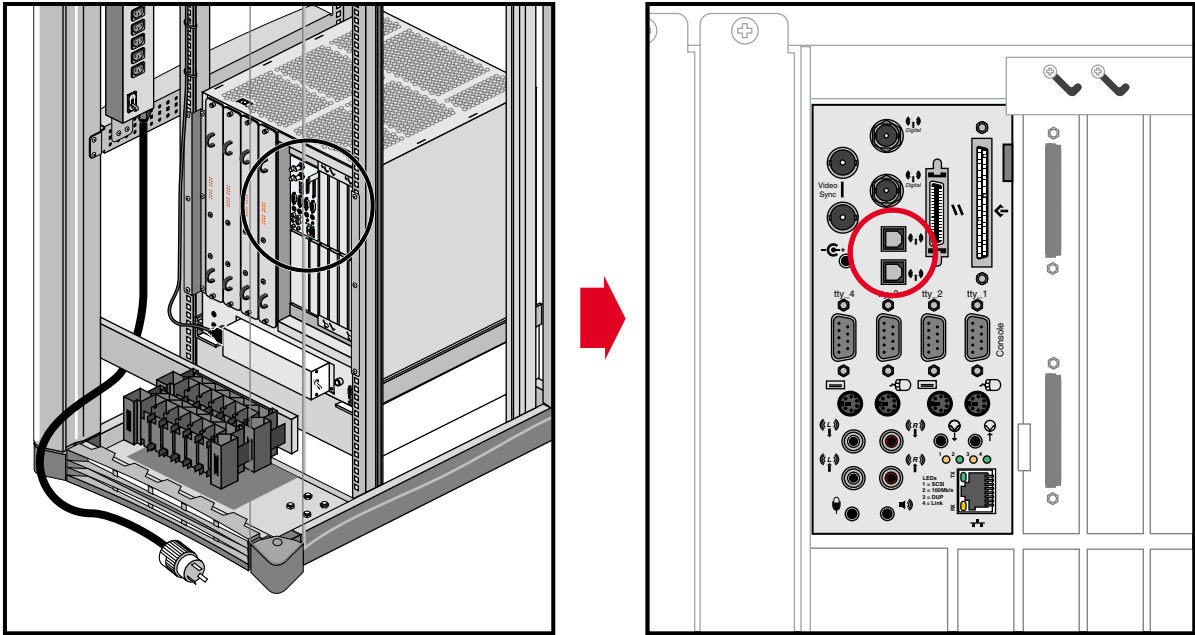


Figure 3-20 Optical Digital Audio Interface

## Loopthrough and Digital Audio Connectors

Figure 3-21 shows the loopthrough and digital audio connectors.

The AES-3id-1995 digital audio connectors support 75 ohm signals at a nominal 1.0 volts (peak-to-peak) signal level. You should use 75 ohm coaxial cable with standard BNC connectors for interconnections (such as with digital video recorders).

Some equipment supporting AES-3id-1995 digital audio signals uses 3-pin XLR connectors that support balanced 110 ohm signals. To successfully interconnect with equipment of this type, install a digital audio "BALUN" adapter at the equipment's XLR connector points. The BALUN adapter connects the 3-pin XLR to a 75-ohm BNC connection. The 75 ohm coaxial cable then connects between the Onyx2 system and the BALUN adapter.

**Note:** 110 to 75 ohm digital audio BALUN adapters come in male and female versions. You need one of each type when using both the input and output AES-3id-1995 signal connectors.



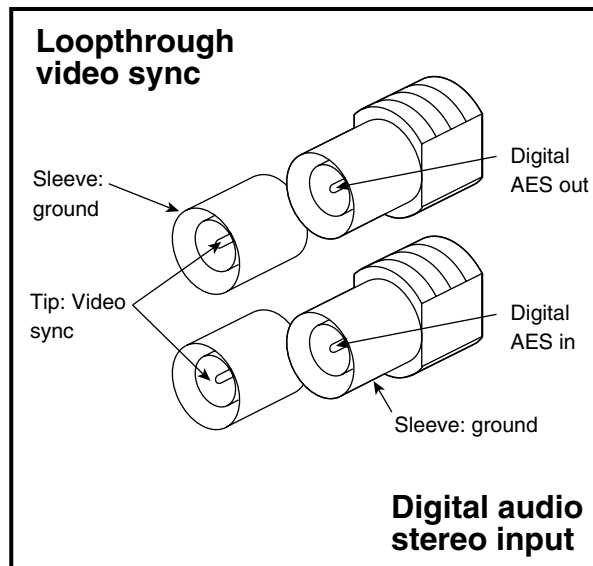
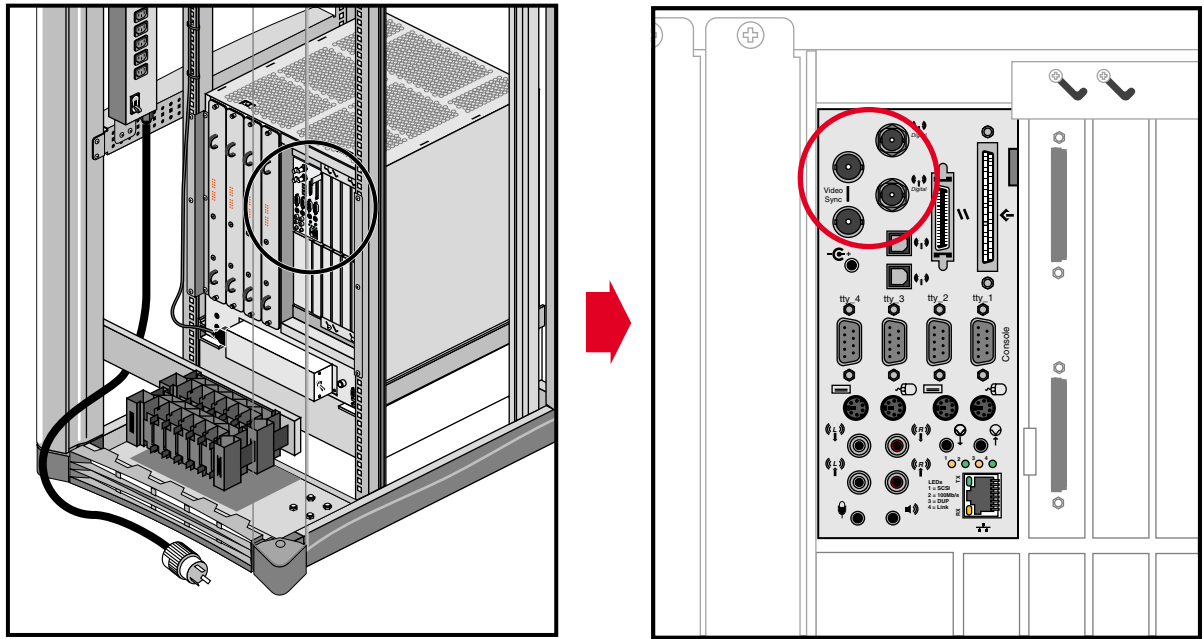


Figure 3-21 Loopthrough and Digital Audio Connectors

## Standard SCSI Connector

A single-ended external 68-pin SCSI connector is provided on the BaseIO panel (see Figure 3-22). This single-ended connector supports both ultra SCSI and SCSI-2 devices. The connector is only single-ended.

Optional additional SCSI ports can be implemented using XIO option boards.

The hyphen preceding a signal name indicates that the signal is low. Note that 8-bit devices that connect to the P-cable leave these signals open: -DB(8), -DB(9), -DB(10), -DB(11), -DB(12), -DB(13), -DB(14), -DB(15), -DB(P1). All other signals are connected as shown in Table 3-8.

**Table 3-8** 68-Pin Single-Ended, High-Density SCSI Pinouts

Signal Name	Pin Number	Pin Number	Signal Name
Ground	1	35	-DB(12)
Ground	2	36	-DB(13)
Ground	3	37	-DB(14)
Ground	4	38	-DB(15)
Ground	5	39	-DB(P1)
Ground	6	40	-DB(0)
Ground	7	41	-DB(1)
Ground	8	42	-DB(2)
Ground	9	43	-DB(3)
Ground	10	44	-DB(4)
Ground	11	45	-DB(5)
Ground	12	46	-DB(6)
Ground	13	47	-DB(7)
Ground	14	48	-DB(P)
Ground	15	49	Ground

**Table 3-8 (continued)** 68-Pin Single-Ended, High-Density SCSI Pinouts

Signal Name	Pin Number	Pin Number	Signal Name
Ground	16	50	Ground
TERMPWR	17	51	TERMPWR
TERMPWR	18	52	TERMPWR
Reserved	19	53	Reserved
Ground	20	54	Ground
Ground	21	55	-ATN
Ground	22	56	Ground
Ground	23	57	-BSY
Ground	24	58	-ACK
Ground	25	59	-RST
Ground	26	60	-MSG
Ground	27	61	-SEL
Ground	28	62	-C/D
Ground	29	63	-REQ
Ground	30	64	-I/O
Ground	31	65	-DB(8)
Ground	32	66	-DB(9)
Ground	33	67	-DB(10)
Ground	34	68	-DB(11)

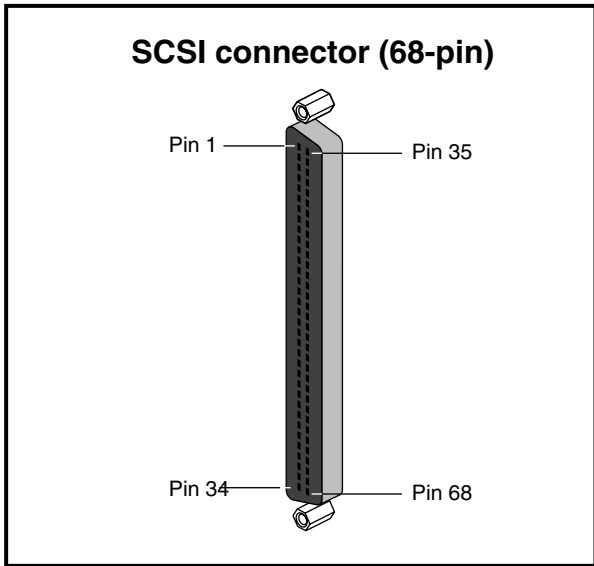
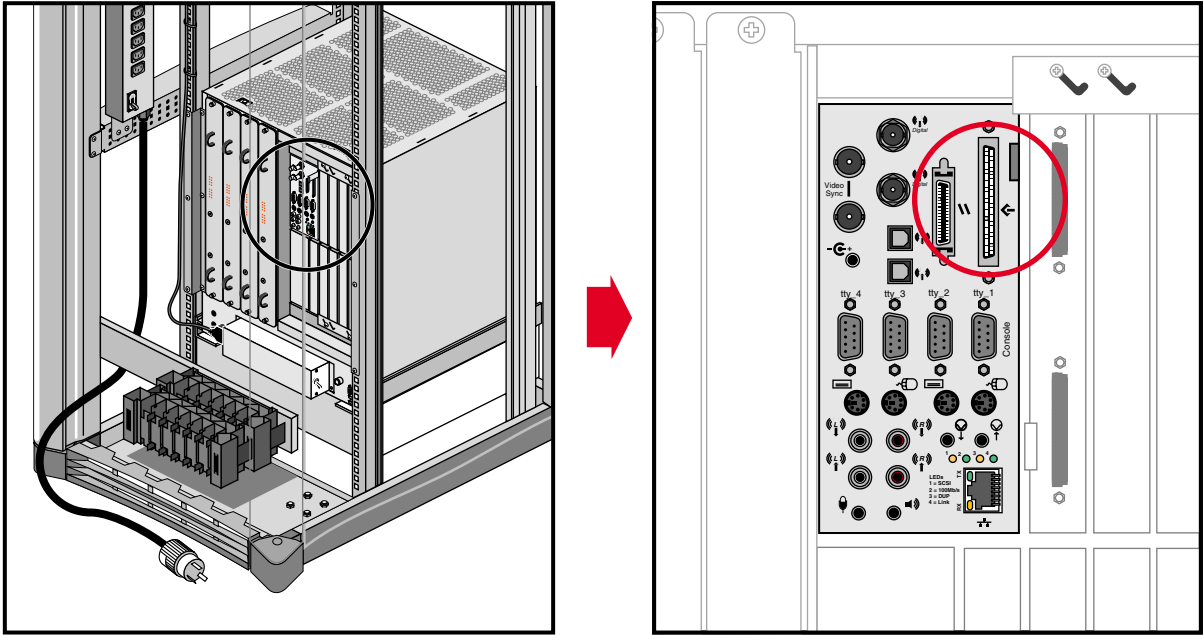
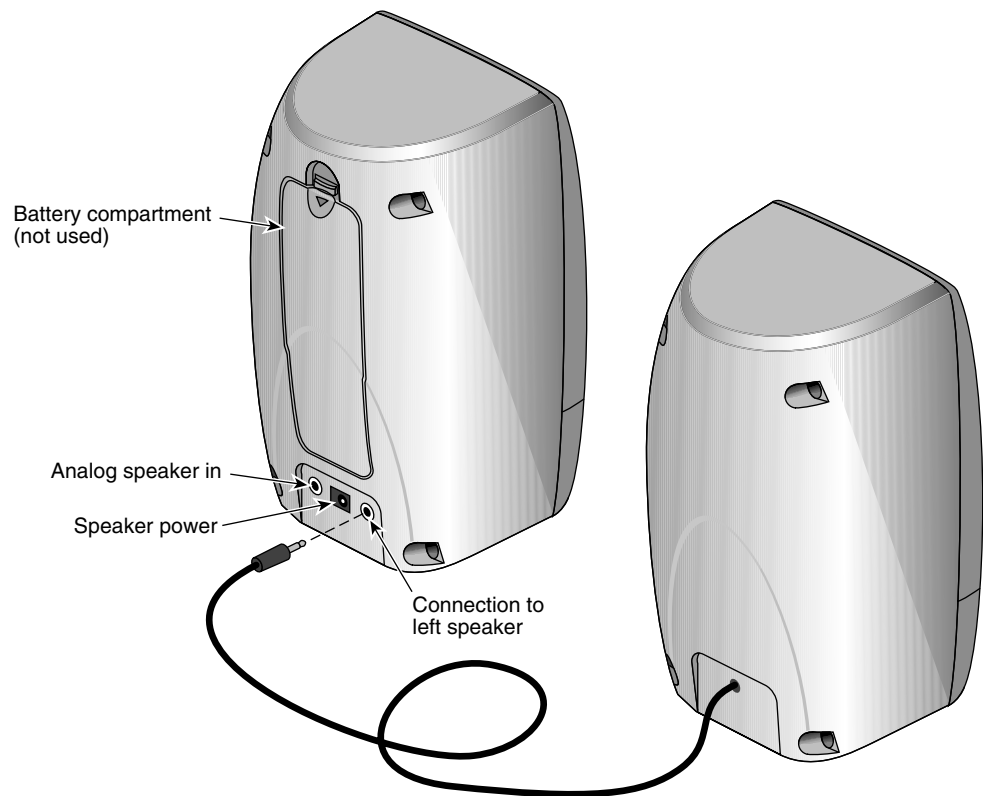


Figure 3-22 68-Pin Single-Ended SCSI Connector

## Speaker and Microphone Connections

The Onyx2 BaseIO panel uses a 30-foot (9.1 m) three-connector bundled cable to make connection to a microphone and a pair of speakers (included with your Onyx2 system).

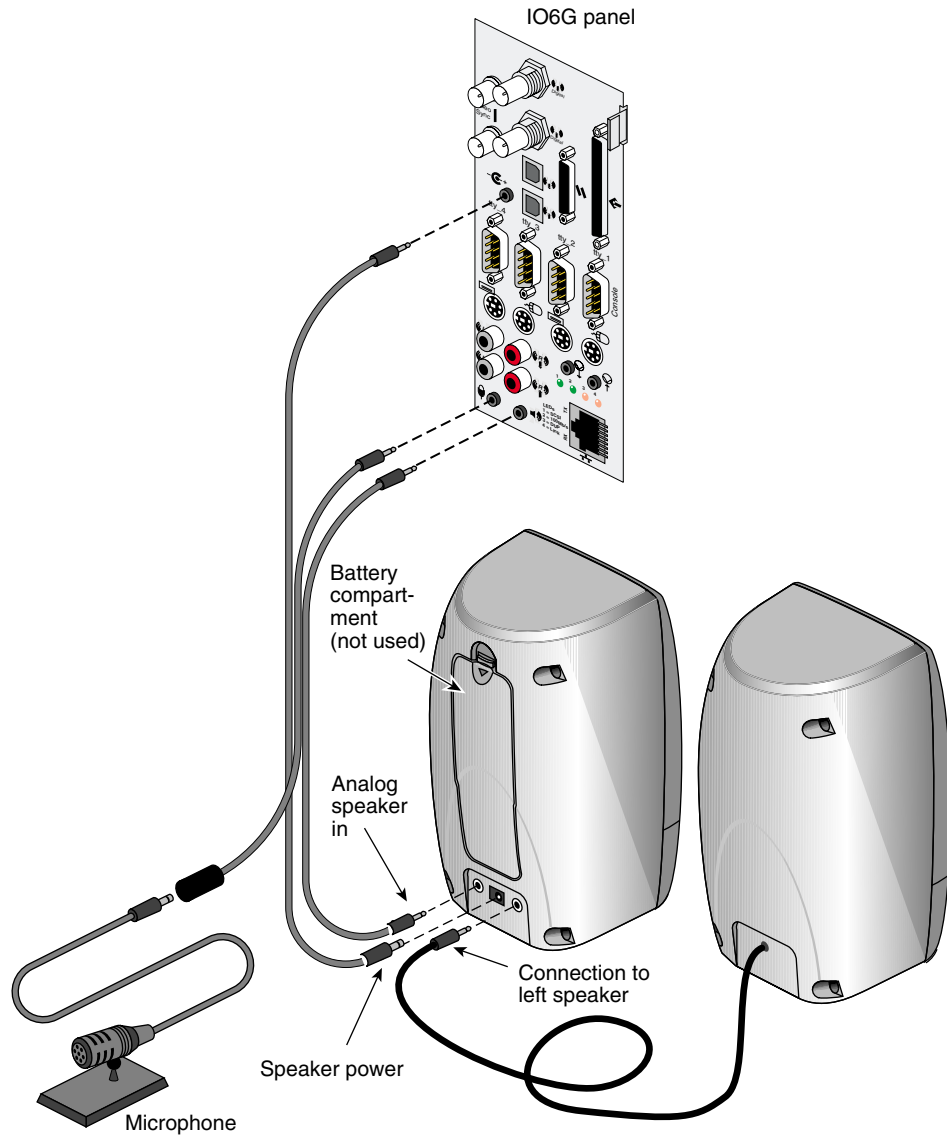
Figure 3-23 shows the connection points on the rear of the speakers.



**Figure 3-23** Cable Connection Locations on the Speakers

The analog speaker connector plugs into the BaseIO board and the other end goes to the analog speaker plug. The analog speaker power connector goes from the BaseIO to the middle plug on the back of the right speaker (see Figure 3-24).

The microphone connector goes from the BaseIO panel and you plug in your microphone (included) at the other end (look for the microphone logo on the connector).



**Figure 3-24** Speaker and Microphone Connections to the BaseIO

Note that there is also a 10-foot (2 m) “speaker only” cable included with your Onyx2 system. This 10-foot cable does not supply a microphone plug and limits where you may place the speaker set.

Connections and cables for optional XIO boards are covered in the individual manuals shipped with each product.





---

## Getting Started

This chapter describes how to configure and operate your system correctly. Always observe the following safety information when working with the system.



**Warning:** The Onyx2 rackmount graphics system operates on 220-240 VAC. Use extreme caution when working around this voltage. Never install or remove power cords without first turning off the equipment.

There is voltage present on the module's midplanes even if the system has been reset or halted.

**Caution:** The Onyx2 graphics rack comes with one or more 24-inch SuperWide color monitors. Always use two people to move the monitors. Be sure to practice proper lifting techniques.

Customer maintenance is limited to the outside of the chassis, where the peripherals and cables attach to the I/O panel. No user-serviceable parts are found within the chassis.

**Note:** This product requires the use of external shielded cables in order to maintain compliance with Part 15 of the FCC rules.

## Using Your Monitor

A high-resolution, SuperWide (1920x 1200-pixel) 24-inch monitor ships as the standard monitor for the Onyx2 rackmount systems. This section describes the 24-inch monitor. Connect the monitor by following the steps in the applicable section.

**Caution:** Before plugging any monitor into either a 110 VAC or a 220–240 VAC outlet, be sure that the electrical rating on the label is in either the 110 or the 220–240 volt range, whichever applies.

When using a monitor in locations that do not have either of these outlets, contact your Silicon Graphics system support engineer before plugging in the monitor power cable.

**Note:** If you are using a monitor not shipped with your Onyx2 system that has adjustable RGB connectors, make sure they are in the 75-ohm position; otherwise, the monitor displays the wrong colors.

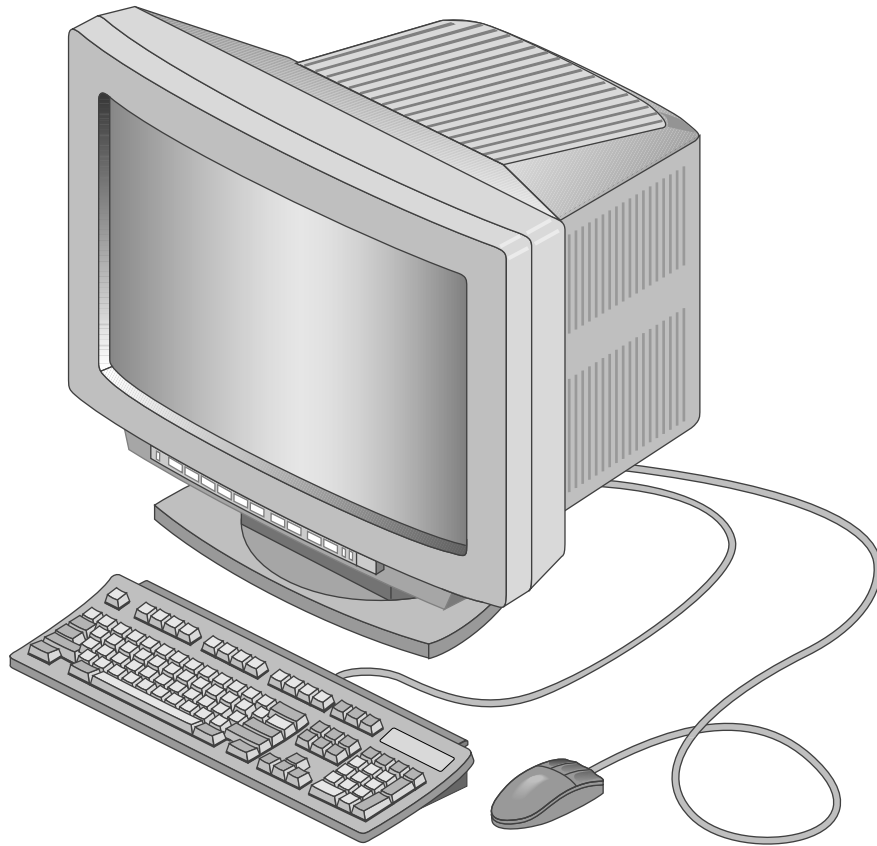
Use only the cables specified to connect the monitor to the Onyx2 rackmount chassis.

The section “DG5 Board Operation” in Chapter 3 has specific information on cabling options for the Onyx2 graphics rack system.

### Connecting a 24-Inch Monitor

The InfiniteReality graphics system uses a 24-inch, high-resolution monitor. This monitor uses a 13W3-to-13W3 cable. Connect one of the fittings to a 13W3 connector on the DG5 graphics board panel and the other to the back of the monitor. See Figure 4-1 for an example of the 24-inch monitor.

When the system is booted, the monitors operate in their default resolution. To change the default video format, you may use the *setmon* command. For more information about the *setmon* command options, see the *setmon(1G)* reference (man) page.



**Figure 4-1** 24-Inch SuperWide Monitor

## **Keyboard and Mouse Connections**

Your system comes with a standard 101-key international keyboard and a mouse. The section “Mouse and Keyboard Ports” in Chapter 3 shows the locations of the two sets of ports on the graphics BaseIO panel.

Each system comes with a 24-foot (7.3 m) “extension” cable that connects to the BaseIO panel. Plug the keyboard and mouse into the end of this cable.

## SCSI Requirements and Configurations

All Onyx2 rackmount systems are configured with one external SCSI channel on the BaseIO (IO6G) board. This standard 68-pin ultra SCSI or SCSI-2 channel is always single-ended.

The difference between single-ended and differential SCSI channels is defined as follows: A single-ended SCSI channel pairs each signal line with a ground line. Differential SCSI channels pair each signal line with a second signal that is the balanced inverse of the first. This configuration makes differential SCSI less susceptible to signal degradation due to noise and more suitable for remote (longer) cabling.

The requirements and limitations of both single-ended and differential SCSI channels are:

- The maximum allowable length for single-ended (standard) SCSI cabling is 19.6 feet (6 meters). This maximum length reflects the combined lengths of both the internal and external cables.
- The maximum allowable length for differential SCSI is 82 feet (25 meters). As with single-ended SCSI, this length is the sum of both the internal and external cables.

**Note:** The most common reason for SCSI device failure is insufficient noise margins due to exceeding the maximum cable length, cable impedance mismatches, or a combination of both. If you are having trouble with certain devices, particularly external devices, be sure to verify that you have not exceeded the maximum SCSI cable length.

Always use the shortest cable possible. Route external cables away from potential damage due to foot traffic, cleaning, and so on.

To operate multiple external SCSI devices, you must order optional XIO SCSI boards that plug into the XIO cardcage.

If you have additional questions about SCSI connections and cable lengths, contact your Onyx2 sales or support representative.

## Connecting Your System to an Ethernet

The Onyx2 graphics workstation comes with a single standard Ethernet connector. You can order optional XIO boards for additional Ethernet connections. See the section “10/100 BaseT Ethernet Port” in Chapter 3 for information on the location and pin assignments of the standard Ethernet connector.

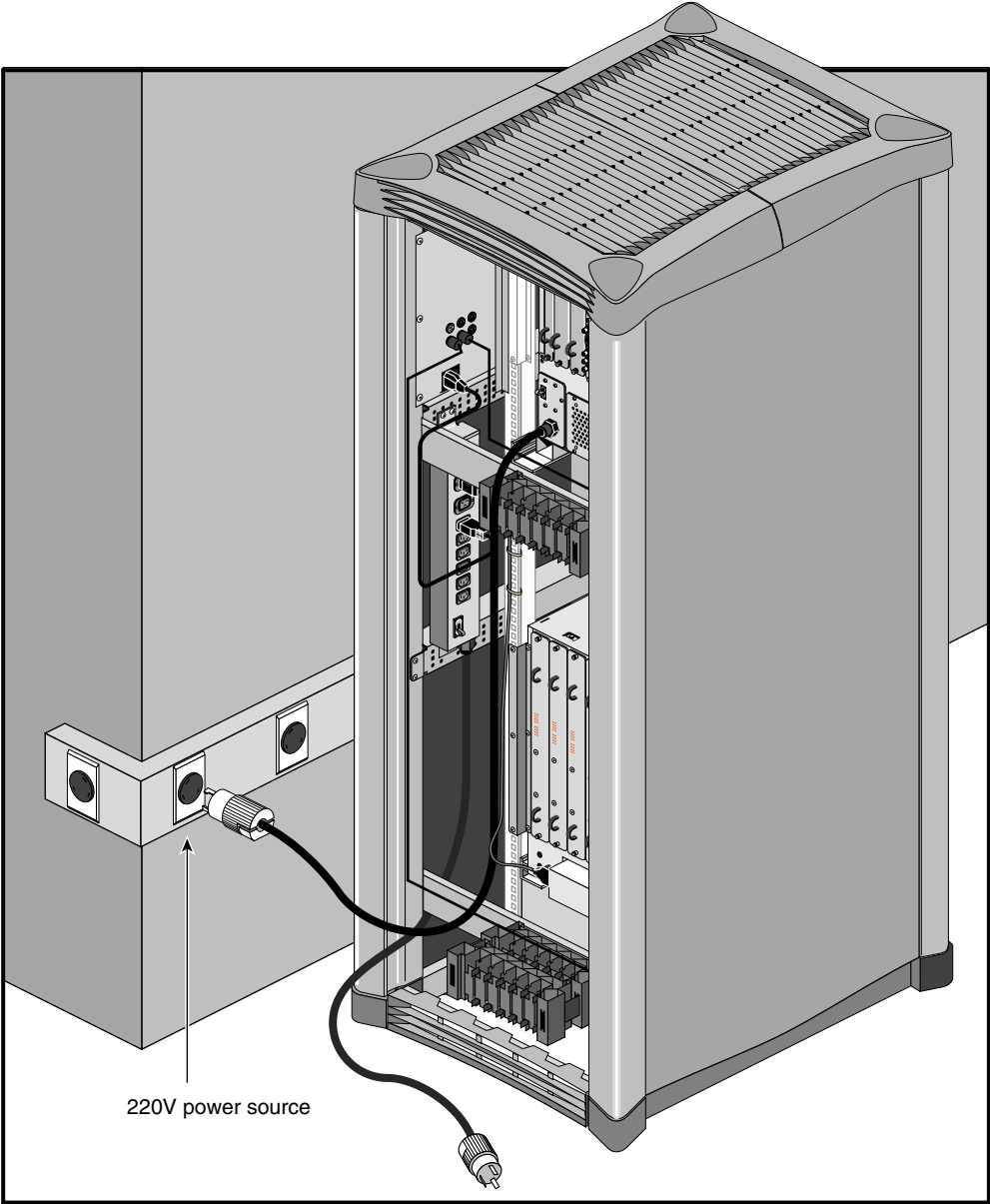
## System Power-On Procedures

Power-on the Onyx2 rackmount graphics system as follows:

1. If the system is completely shut down, verify that the power distribution unit’s (PDU’s) power switch is turned off and that each graphics module power switch is in the off position.
2. Connect the power cable of each graphics module to a 220-240 VAC wall receptacle (see Figure 4-2).
3. Power-on all graphics modules by flipping the breaker switch up and into the on position.
4. Turn each graphics module System Controller (MSC) keyswitch to the on position (see Figure 4-3).



**Warning:** The rackmount system operates on 220-240 VAC. Use extreme caution when working around this voltage. Never install or remove power cords without first turning off the equipment.



**Figure 4-2** Connecting a Graphics Module Power Cable

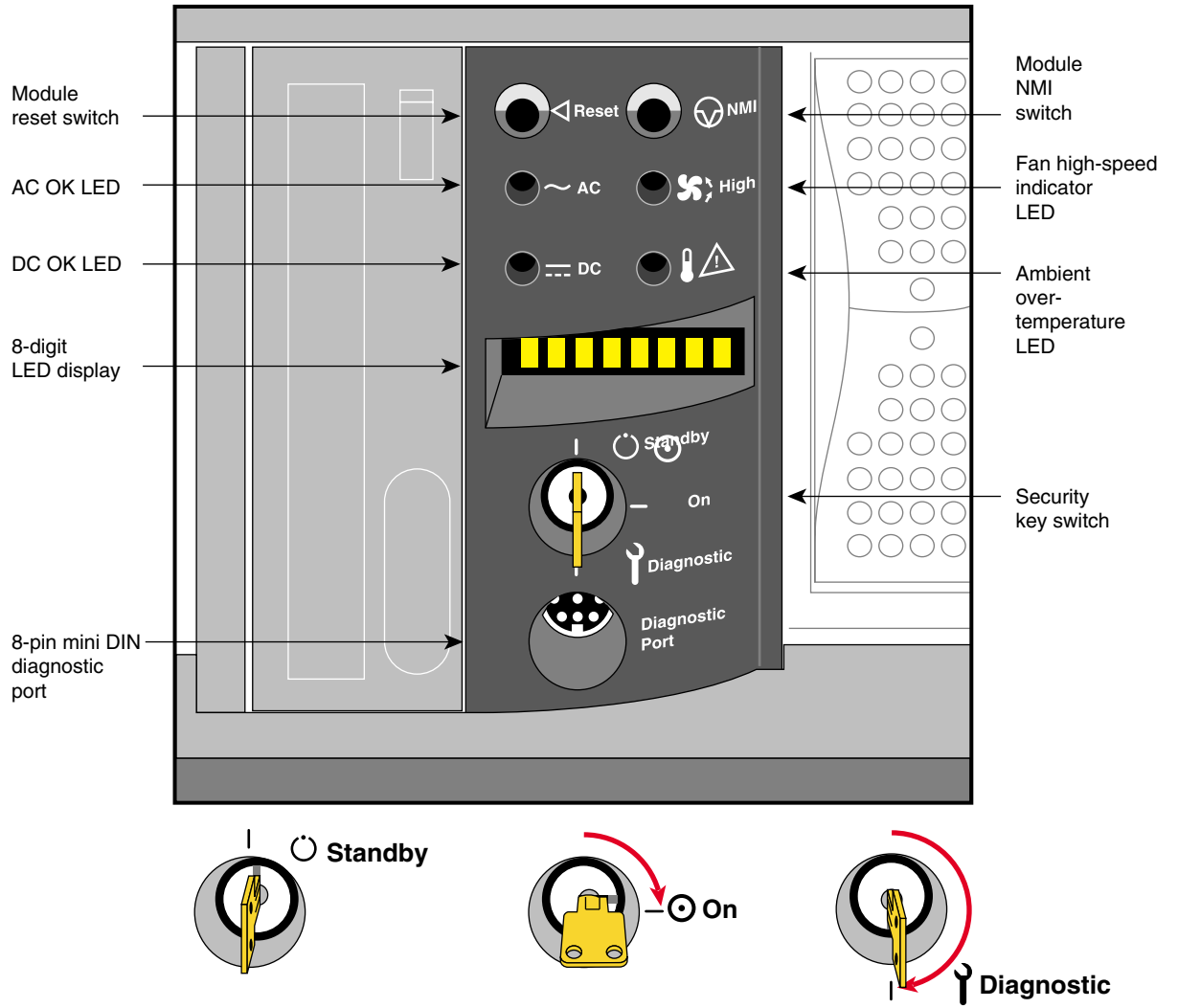
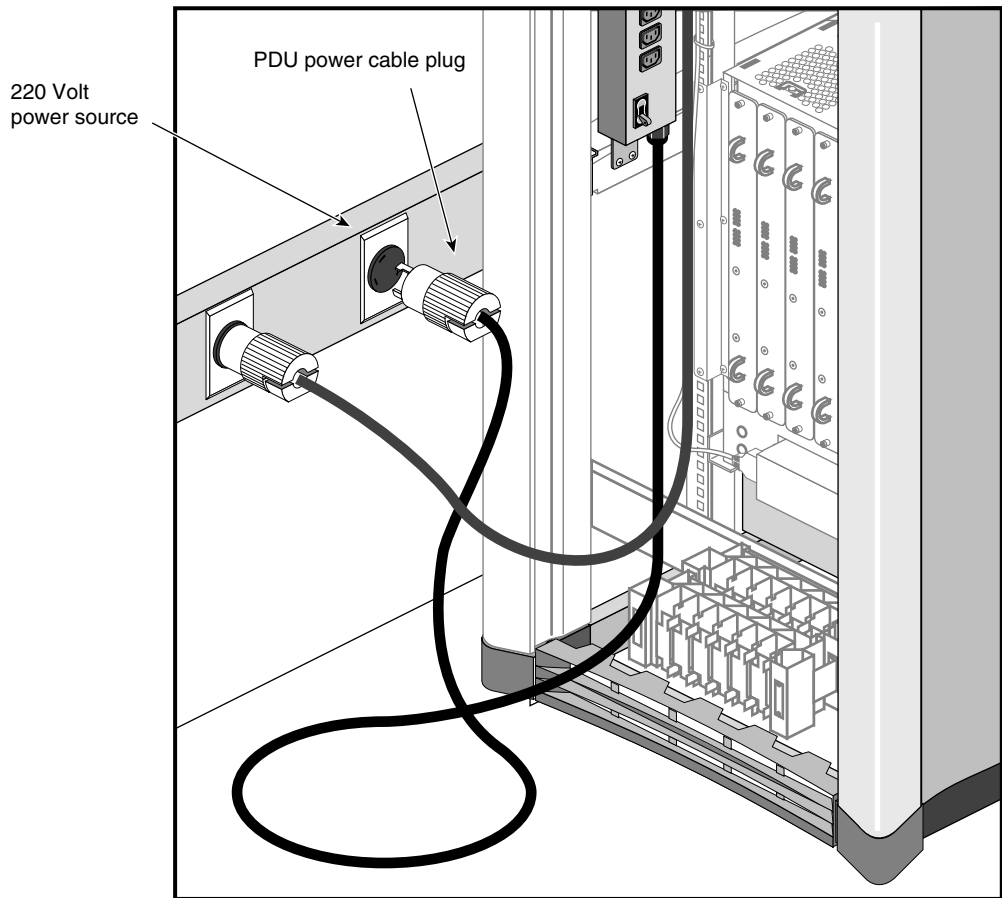


Figure 4-3 MSC Key Positions

5. Insert the power distribution unit's (PDU's) power cable into the 220-240 VAC wall receptacle (see Figure 4-4). The power receptacles used for the graphics module and PDU should be sourced and grounded from the same breaker box. For additional information on this topic, see the *Site Preparation for Origin Family and Onyx2* manual (P/N 007-3452-001 or later version).

**Caution:** Any difference in ground potential greater than 500 millivolts (0.5 V) between two chassis connected together with CrayLink or crosstown cables can cause severe equipment damage.



**Figure 4-4** Connecting the PDU Power Cable



6. Connect the power cords of the compute module and the Origin Vault drive expansion box into the PDU.

**Caution:** If you have a multirack graphics system, the processor compute module *must* be plugged into the PDU that is supplied with the rack. *Do not* use a power source outside of the chassis. The CrayLink Interconnect cabling scheme requires that the compute modules share a common AC ground. This helps prevent possible damage to internal hardware components.

7. Connect each multimodule System Controller (MMSC) power cord to the PDU.
8. Turn the PDU power switch to the on position (see Figure 4-5).

**Note:** In a multirack graphics system always power-on the MMSC logic unit in the primary rack (the one with the interface panel) last. The primary MMSC pages its network for additional MMSCs only at power on. Therefore, any additional MMSC logic units must already be on line to be recognized.

9. Place the breaker switch on the back of the Origin Vault in the on position.
10. Push the button on the front of the Origin Vault drive box to fully power it on.
11. If the monitors and peripherals are equipped with voltage select switches, verify that they are set for the appropriate AC voltage.
12. Connect the power cords from the monitor(s) and any additional peripherals to the appropriate three-pronged grounded outlets and turn them on.
13. Turn on the processor compute module's main power switch (see Figure 4-6).

**Note:** All internal storage devices are automatically powered on by the MSC.
14. Turn each compute MSC keyswitch to the on position (as seen in Figure 4-3).
15. Go to the next section and boot the system.

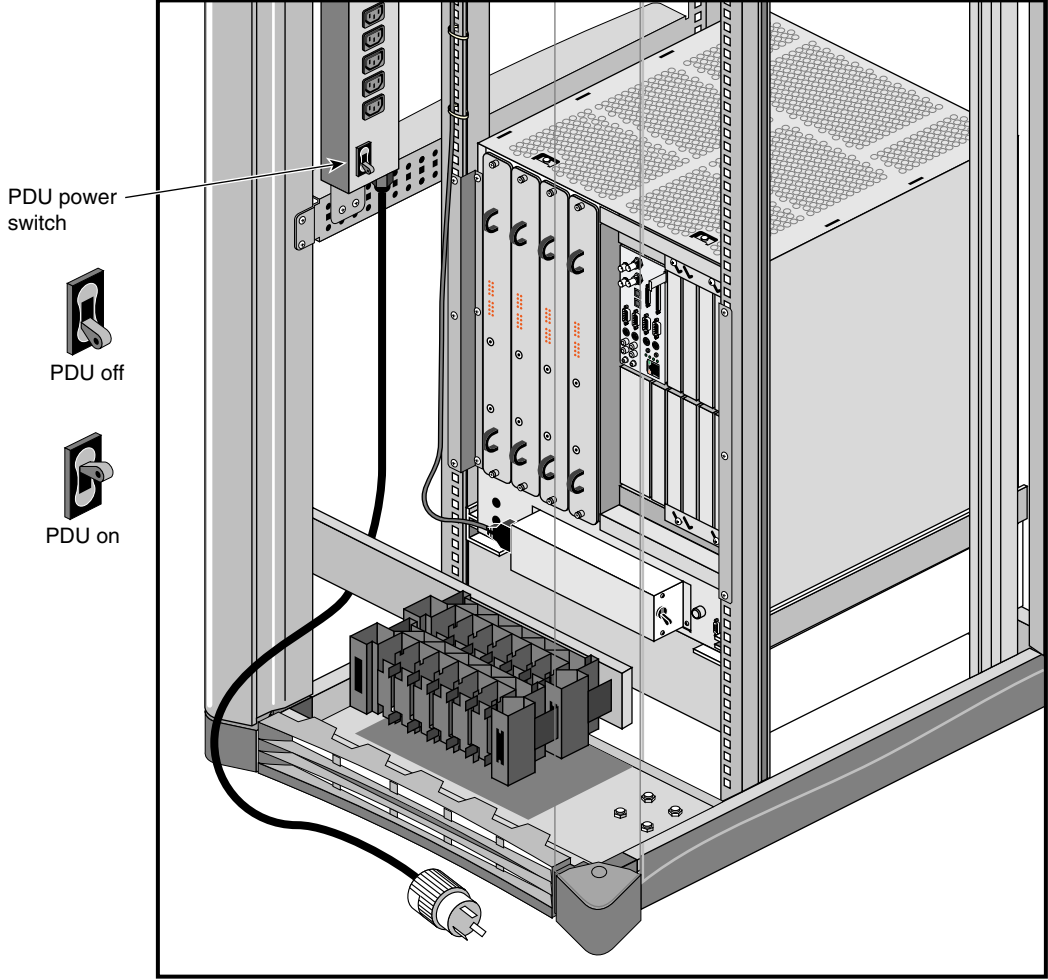
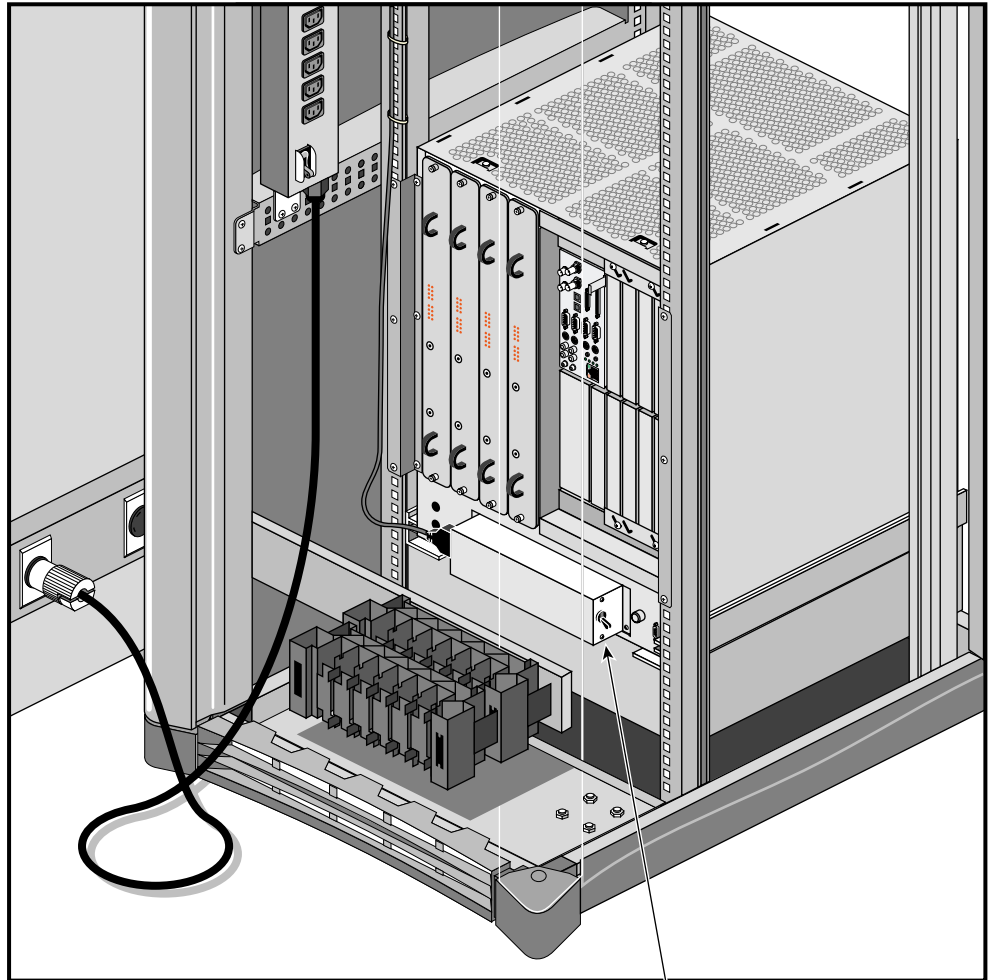


Figure 4-5 Turning On the PDU



Compute module  
power switch



**Figure 4-6** Powering On a Processor Compute Module

## Booting Your System

Boot your system by performing the following steps:

1. With all system power connections in place and all MSCs turned to on, bring the system fully online using the MMSC front panel.  
**Note:** Do not press any of the front panel buttons on the individual MSCs while the rack is still booting. Pressing the buttons during this process interrupts the boot sequence.
2. Press the Menu/Cancel key so that the front panel's cursor is positioned on the main (top) menu.
3. Move the cursor left or right until it covers the Action menu selection.
4. Move the cursor down to the Power Up option.
5. Press the Enter key if you are ready to power up the rack (or Menu/Cancel to abort).

When all system power-on tests have completed, you see this message on your monitor:

```
Starting up the system...  
To perform System Maintenance instead, press Esc.
```



**Figure 4-7** MMSC Power Up Selection

6. To reconfigure your system or to list your system's hardware, press Esc within five seconds.
7. If you do not press Esc within five seconds, the system comes up and displays the desktop. At this time the MMSC interface panel should be displaying the standard processor activity screen, similar to Figure 4-8.



**Figure 4-8** MMSC Interface

8. If you need to access the Command Monitor, log in, shut down the system using the System Shutdown command from the System Toolchest, and then restart it when prompted.
9. When the System Maintenance menu appears, type **5** to select Enter Command Monitor.
10. When the **>>** prompt appears, type **hinv** then press Enter to display the hardware inventory of your system.
11. See the *IRIX Admin: System Configuration and Operation* manual for information on reconfiguring your system.
12. Quit the Command Monitor by typing **Exit** at the **>>** prompt.
13. The System Maintenance menu reappears. Type **1** to select the Start System command. The system comes up and displays the desktop.

## Installing the Operating System

The basic IRIX operating system is factory-installed on your system disk. No operating system software installation is required. If additional software is desired, it must be downloaded either locally (using a CD-ROM drive) or downloaded remotely over the network. See the *IRIX Admin: Disks and Filesystems* manual for additional information about mounting and configuring drives. Refer to the *IRIX Admin: Software Installation and Licensing* manual for the detailed steps required to download the software.

**Note:** A copy of the IRIX operating system is supplied with the system on a compact disc. Place the CD in a secure place in case you ever need to reinstall the operating system.

## Powering Off the System

The system should be powered off only for routine maintenance or repair. You can power your system off using the following information:

1. Start the power off by bringing the IRIX operating system down from a shell.

- Become superuser by typing `/bin/su` and press Enter.
- Enter your superuser password, if prompted.
- When you see the superuser prompt (`#`), type `/etc/halt` and press Enter.

The window interface comes down, and a message similar to the following appears on the screen:

```
Okay to power off the system now.  
Press any key to restart.
```

2. Turn off the power switches for any external peripherals in the following order:
  - printer (if installed)
  - monitors
  - other external peripherals
3. Go to the MMSC front panel and press the Menu/Cancel key to bring the cursor to the top menu.
4. Move the cursor right or left to position it over the Action menu.
5. Push the down cursor placement key until it highlights the Power Down option (see Figure 4-9).
6. Press Enter to power down the rack system (or Menu/Cancel to abort the process).



**Figure 4-9** MMSC Interface

7. Turn the MSC keyswitch on each of the system’s graphics modules to the standby position.
8. Push the button to power off any Origin Vault drive boxes that are being used.
9. Turn the MSC keyswitch on all processor compute modules installed in the system to the standby position.
10. Place each module’s power switch in the off (down) position.
11. Push the Origin Vault’s rear breaker switch to the off position.
12. Turn the switch at the bottom of the power distribution unit to the off position.  
**Note:** In multitrack systems, unplug the PDU power cable from the rack containing the MMSC interface panel last.
13. Unplug the graphic module(s) power cord(s) from the wall socket.
14. Unplug the PDU power cord(s) from the wall socket.

After completing all these steps, all power to the system is cut off.



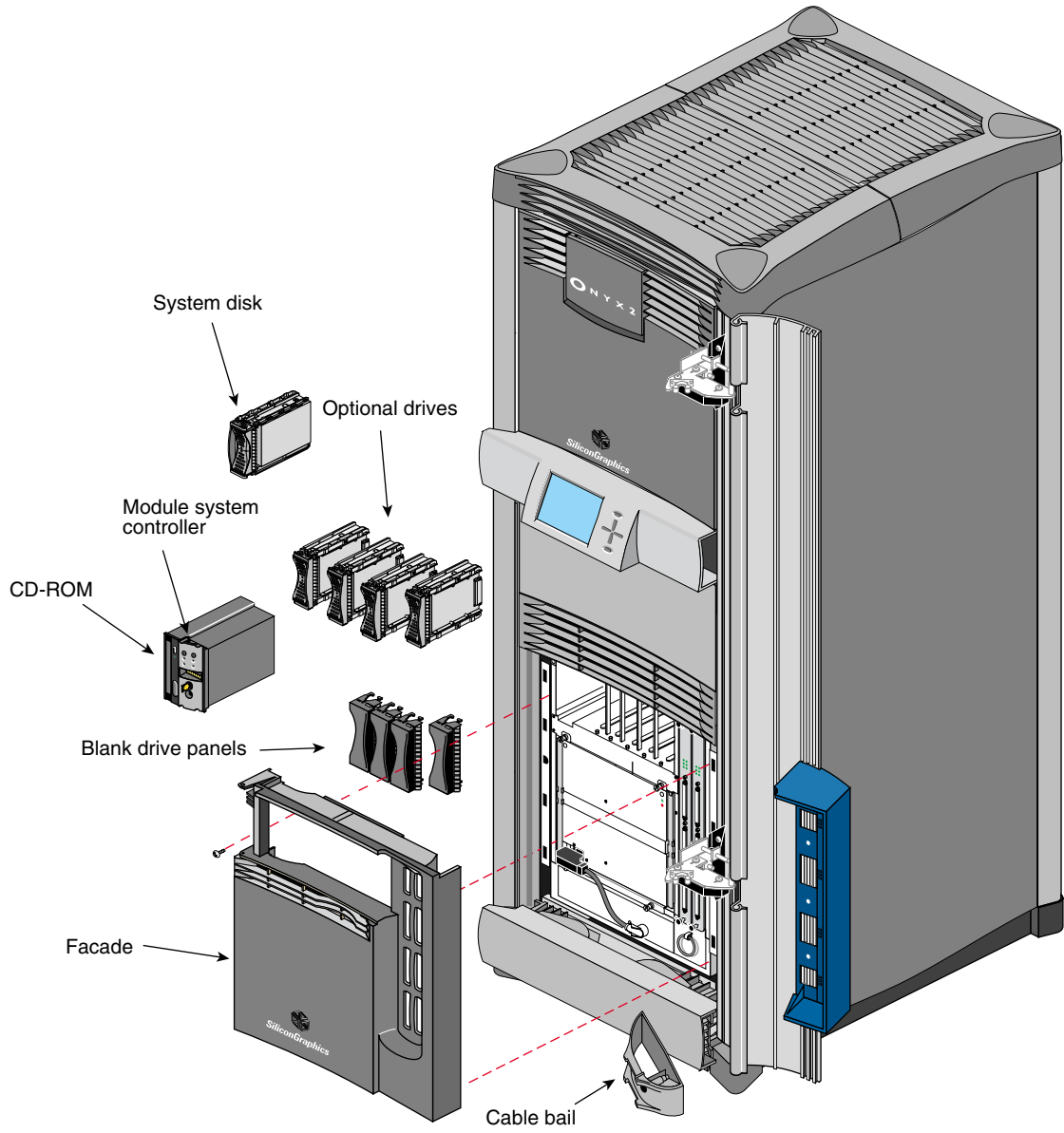
---

## Installing and Replacing Customer-Replaceable Units

This chapter describes the installation and removal procedures for the customer-replaceable units (CRUs) in the Onyx2 graphics rack system. The CRUs are hardware components that can be safely removed by an end user without undue exposure to high electrical power potentials. CRUs are limited to the following major components:

- disk and tape drives
- graphics or compute module System Controller (MSC)
- compute module CD-ROM drive
- front plastic panels (facade)

Figure 5-1 shows an Onyx2 rack with CRUs. Note that the facade on the graphics module is also removable.



**Figure 5-1** Onyx2 Rackmount Customer-Replaceable Units

## General Safety Information

Read the following subsections for general safety information.

Before beginning any replacement procedures, observe these precautions.



**Warning:** This equipment uses electrical power internally that is hazardous if the equipment is improperly disassembled.

**Caution:** This equipment is extremely sensitive and susceptible to damage by electrostatic discharge (ESD). The buildup of electrical static potential on clothing and other materials may cause ESD.

Use proper ESD preventive measures and observe these precautions:

- Wear a properly grounded wrist strap when connecting and disconnecting peripherals.
- Be sure that you and all the electrical equipment you handle are at ground potential to avoid damage from ESD.

## Before Replacing Any Components

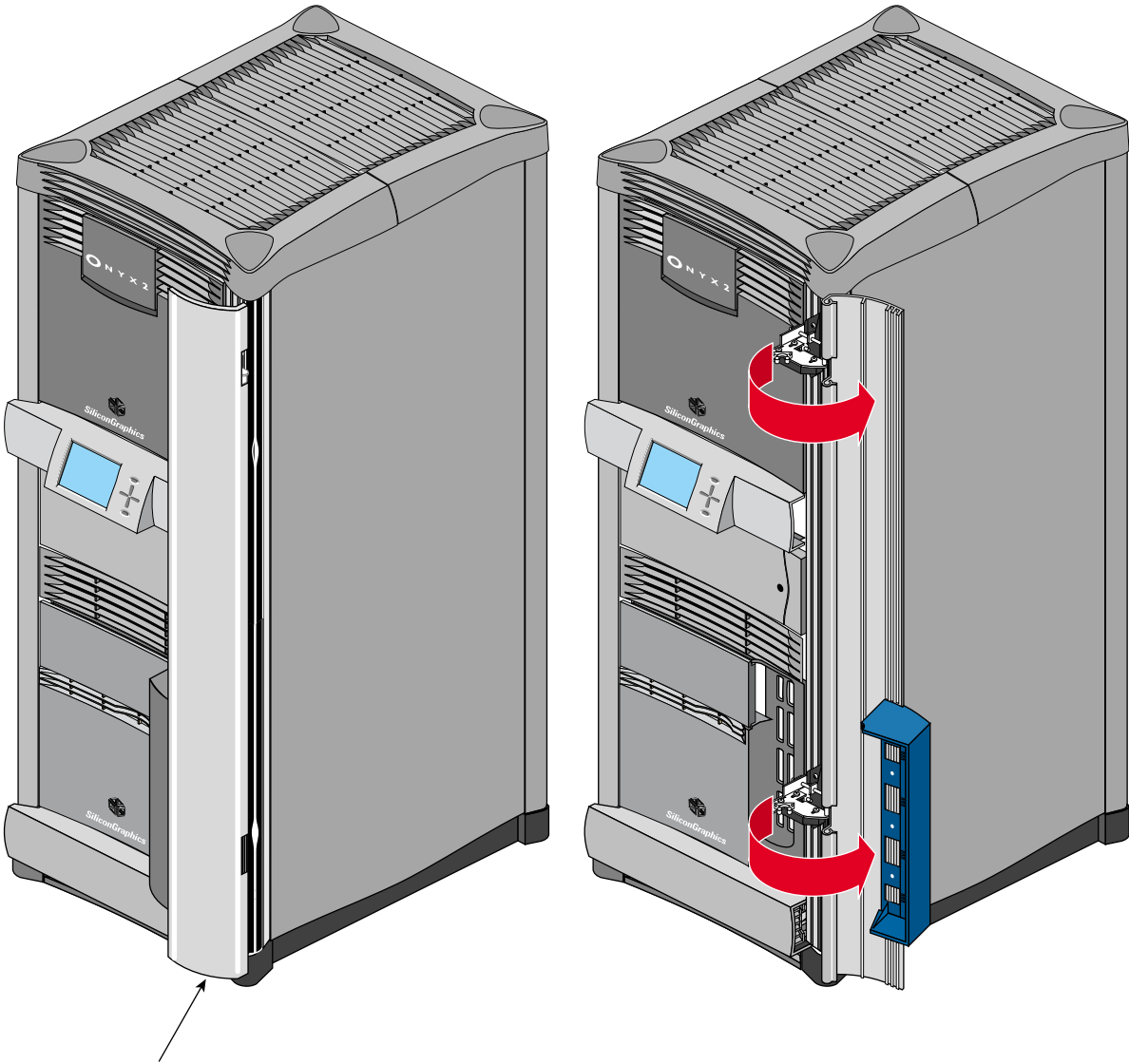
Ensure that the system files are backed up, and that all users are logged off the system. Always completely power off the system when removing or replacing internal components.

“Powering Off the System” in Chapter 4 provides step-by-step details on the proper process for turning off and disconnecting all system power.

“System Power-On Procedures” in Chapter 4 gives the procedures for bringing the rack back online after adding, removing, or replacing internal components.

## Opening the Cable Cover Door

The cable cover door (see Figure 5-2) provides aesthetic shielding for the CrayLink Interconnect cabling on the rackmount chassis between a side-by-side graphics rackmount system.



Cable cover door for CrayLink interconnect

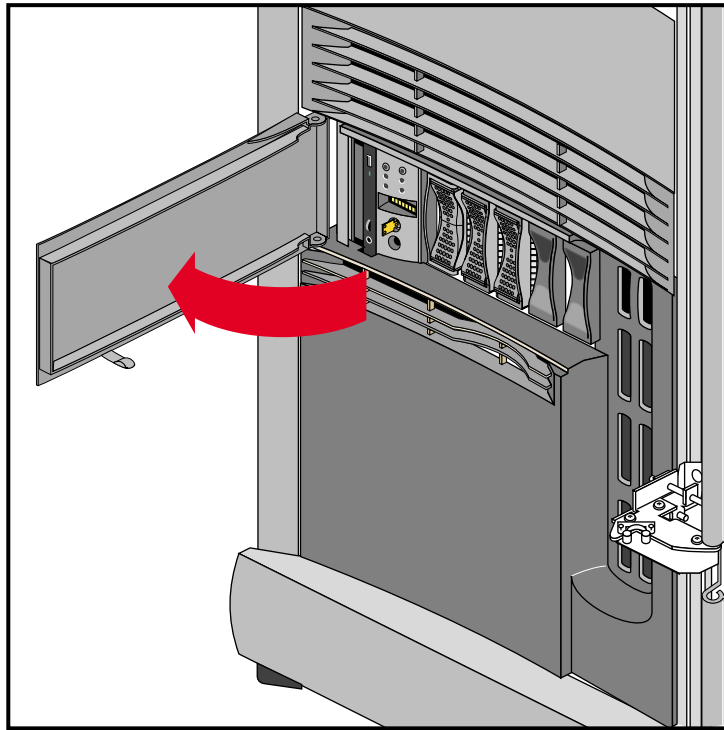
**Figure 5-2** Opening the Cable Cover Door

## Opening and Closing the Compute Module Drive Door

Use this procedure to open and close the compute module's drive door on a rackmount system:

1. Swing open the drive door as shown in Figure 5-3.
2. Close the door by pushing it all the way in to engage the plastic tab on the bottom of the door.

**Note:** The door should normally be in the closed position to help keep away dust and other possible contaminants from the drives and MSC.



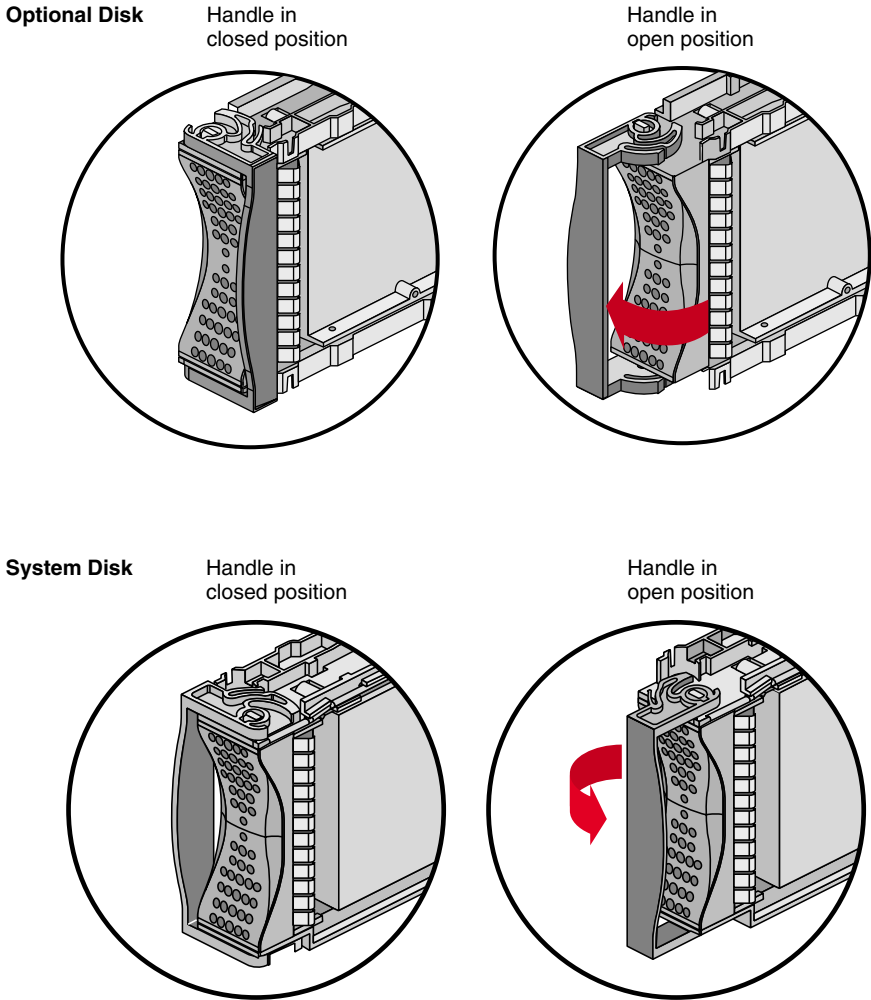
**Figure 5-3** Opening the Compute Module's Door

## **CRU Remove and Replace Procedures**

The following sections provide instructions for replacing the customer-replaceable units (CRUs). To replace an CRU, refer to Figure 5-1 to help identify the appropriate unit and its position in the chassis. Then proceed to the appropriate section and perform the steps.

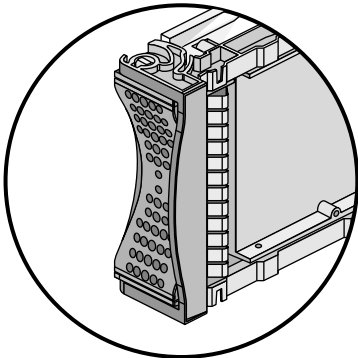
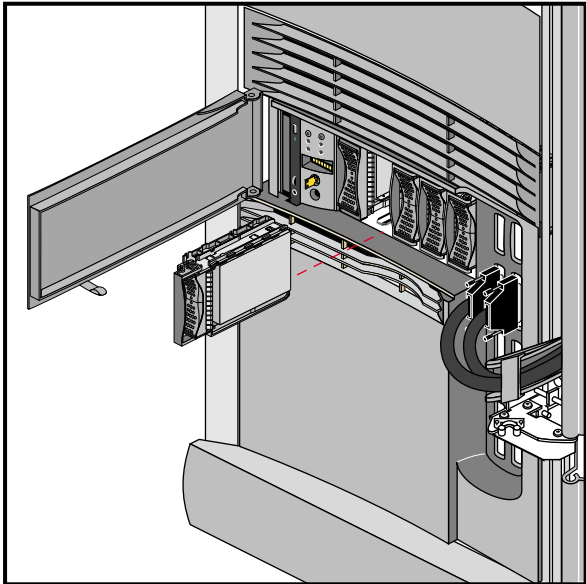
### **Removing a Drive Module**

Disk drives in the compute module are aligned vertically at the front of the chassis. Note that the leftmost disk drive—the system disk—is oriented differently from the others as shown in Figure 5-4.

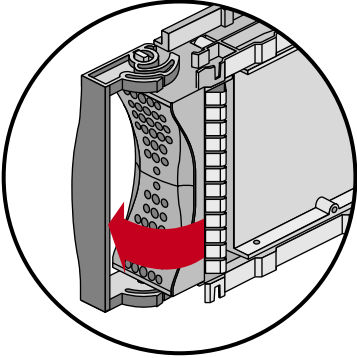


**Figure 5-4** Opening the SCA Disk Drive Units

1. To remove a disk drive module, snap the handle to the right or left (depending on the drive orientation) to the open position. The handle is centered, as shown in Figure 5-4.
2. Pull the disk straight out (see Figure 5-5).



Handle in closed position



Handle in open position

**Figure 5-5** Removing the Drive



To insert a disk module, follow these steps:

1. If necessary, snap the handle to the open position so that it is centered, as shown in Figure 5-5.
2. If you are adding a drive, remove the drive filler plate that covers the drive slot you want to use.
3. Align the new disk module with the drive guide.
4. Gently but firmly slide the disk module on the guides over the pin. When the disk module is all the way in, it snaps.
5. When the disk module is in all the way, snap the handle right to the closed position, as shown in Figure 5-5. In the case of the system disk module, which is upside down relative to the other drives, snap the handle left.
6. Use the packaging for the new disk module to repackage the old disk module.

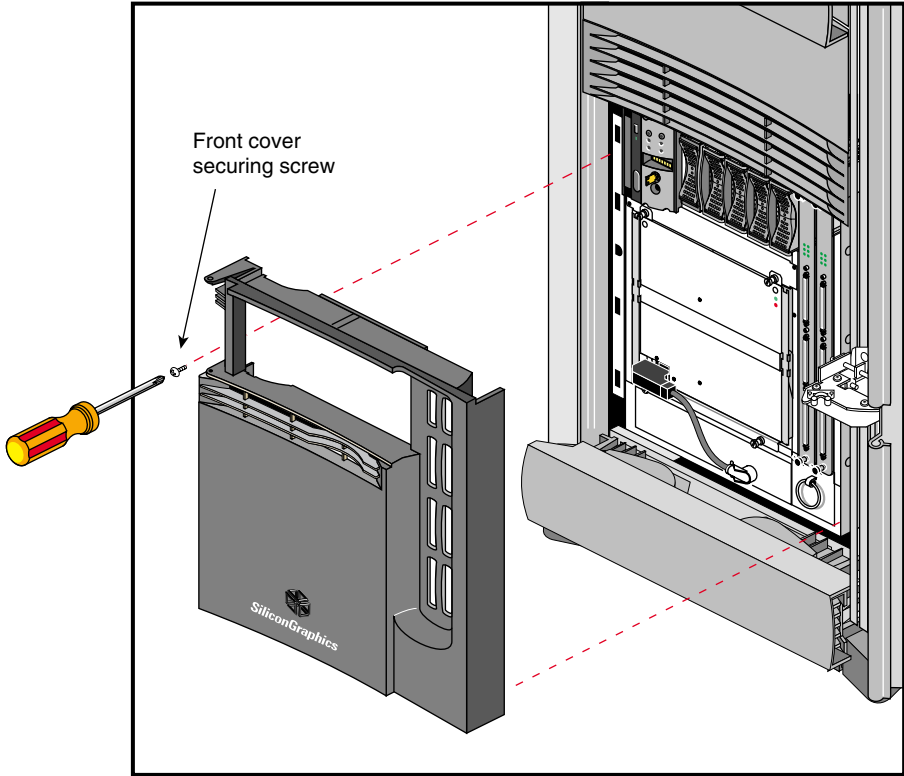
### Removing a Module's Facade

The module's facade must be taken off before you can remove the MSC, CD-ROM assembly, or check the power supply LEDs. Use these procedures to remove the facade:

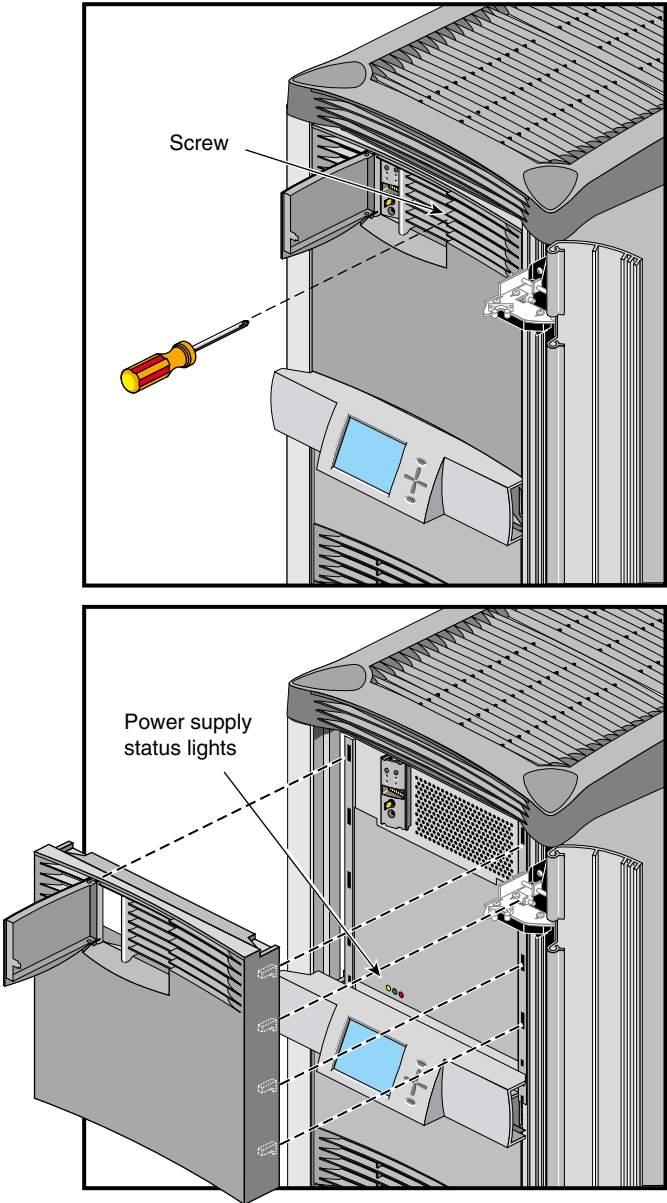
1. Lift off the cable bails that hold the CrayLink Interconnects and Xpress Links cables in place (if applicable).
2. Remove the CrayLink Interconnect and Xpress Links connectors from the rack's Router board ports (as required).

**Caution:** Be sure that the connectors are labeled before you remove them, so that you know where to replug them afterwards.

3. Remove the screw that secures the facade to the chassis (see Figure 5-6). Figure 5-7 shows the screw location on the graphics module.
4. Lift up to disengage the facade from the chassis; then pull it straight out.
5. Reverse these steps to reinstall the facade.



**Figure 5-6** Removing the Compute Module's Facade



**Figure 5-7** Removing a Graphics Module Facade

## Removing the MSC and CD-ROM

The MSC and CD-ROM drive are packaged together in one assembly in the compute module. The graphics module houses only the MSC. To replace either component, you must remove and insert an entire new assembly.

**Caution:** Do not attempt to remove the multimodule System Controller (MMSC) and display. This procedure should only be performed by Silicon Graphics trained or certified personnel.

1. Power off the module the CD-ROM and MSC assembly are being removed from (see “Powering Off the System” in Chapter 4 for details on completely shutting off power to a module).

**Caution:** Simply turning the MSC keyswitch to standby does *not* shut off all power to the module or the MSC.

2. Remove the facade (see “Removing a Module’s Facade” on page 115).
3. Remove and reserve the screws that hold the assembly in place, as shown in Figure 5-8.
4. Insert the new assembly, using the reserved screws.
5. Repackage the old assembly.

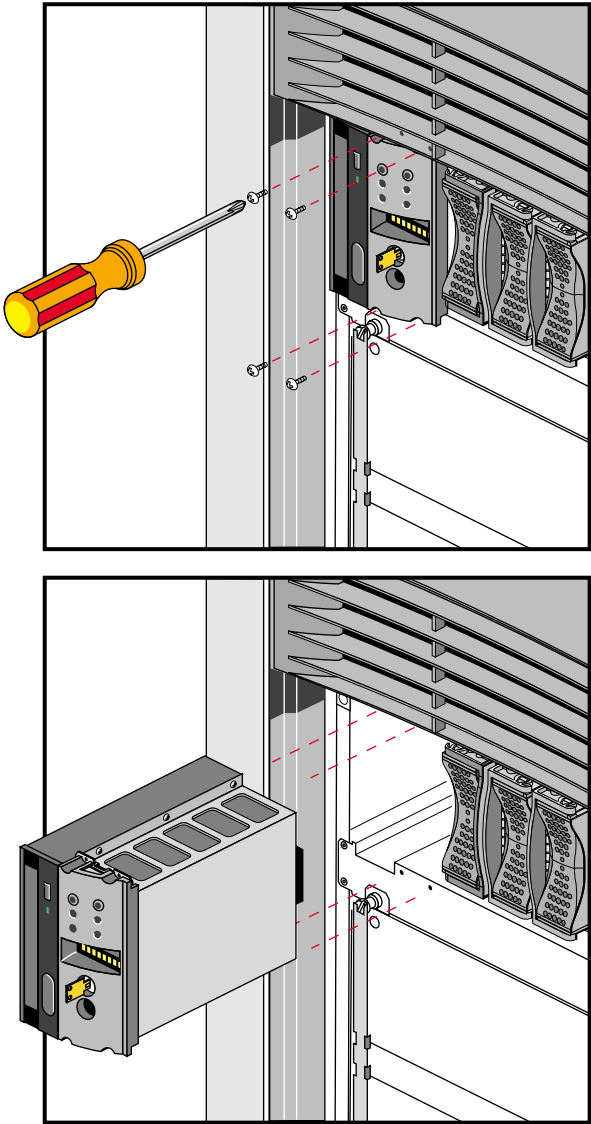


Figure 5-8 Removing the MSC and CD-ROM



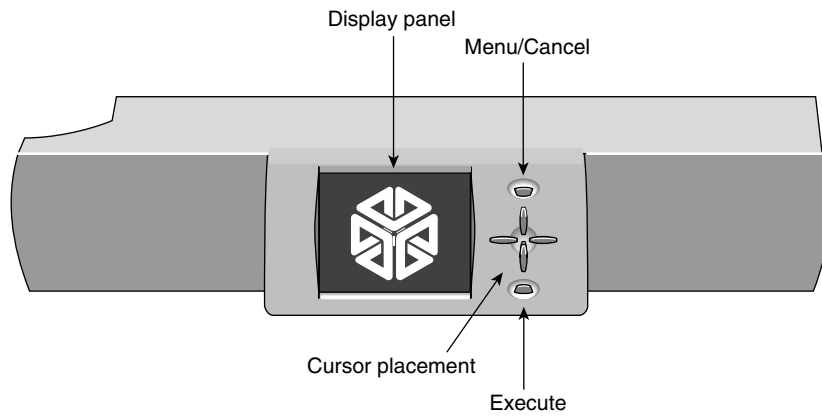
---

## Using the System Controllers

This chapter provides information on using the multimodule System Controller (MMSC) and the module System Controllers (MSCs) in your Onyx2 graphics rack system.

### The MMSC

The MMSC monitors and reports status information from the individual compute and graphics modules in the rack system. Information is displayed and commands can be selected using the front panel display and the select buttons on the front of the rack. Figure 6-1 shows the panel and control buttons.



**Figure 6-1** MMSC Display and Controls

**Note:** There is always one display, even with multitrack systems.

During normal operation, the MMSC interface panel displays a standard processor activity screen, similar to Figure 6-2. The controller interface offers a number of menu items. Select an item by highlighting it with the cursor. Move the cursor by pushing the up, down, left, and right buttons.

To discard a selection, press the top (Menu/Cancel) key. To execute a selection, press the bottom (Enter) key.

The display and keyset is only the interface to the MMSC logic unit. The logic unit must be fully and properly connected and powered on for the display to provide useful information. "System Power-On Procedures" in Chapter 4 provides a system power-on process using the controller interface.



**Figure 6-2** MMSC Interface

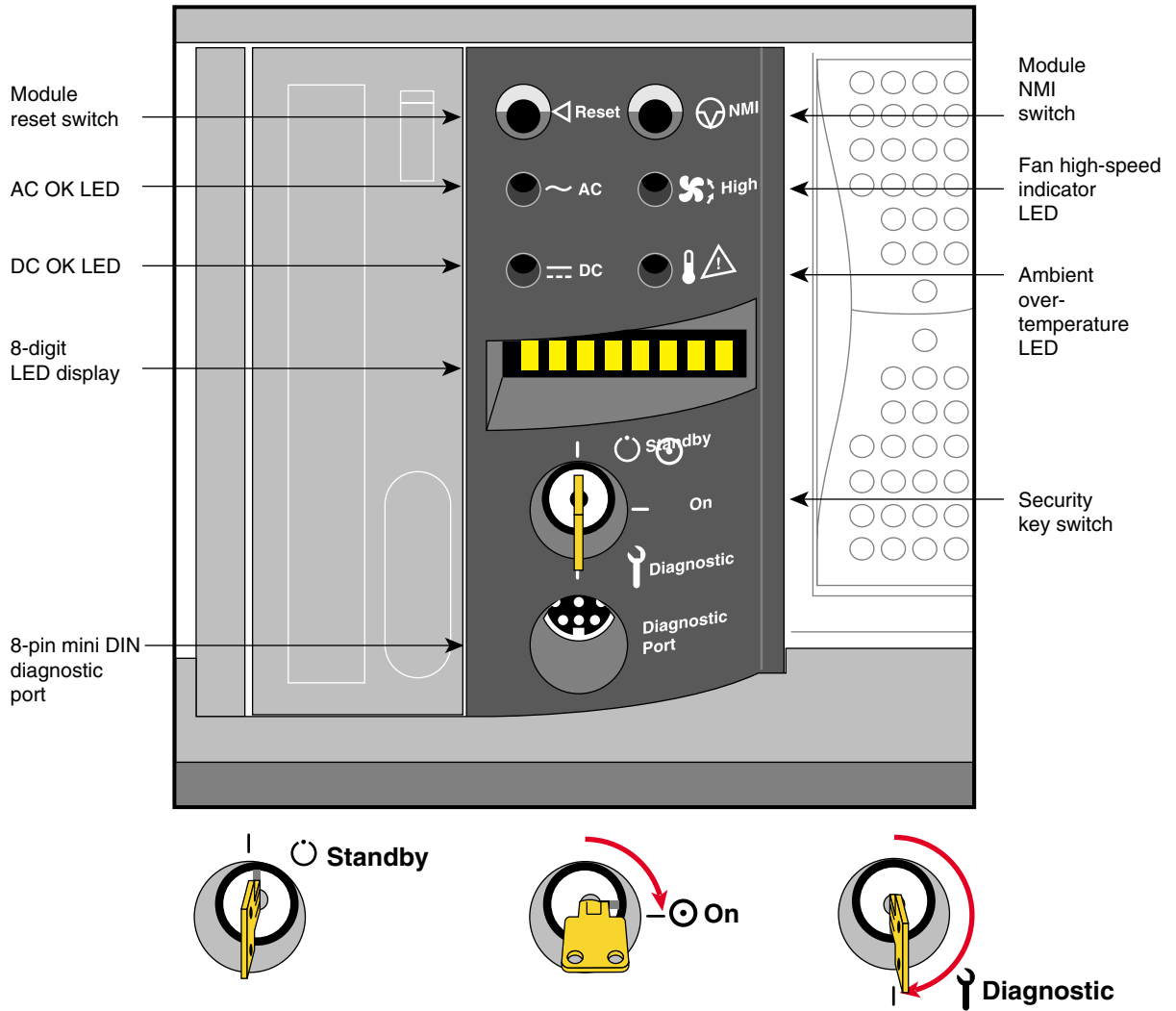


## The MSC

Each module in an Onyx2 graphics rack system has its own MSC. The controller interacts with the power supply, internal fan(s), midplane, node and other boards that have on-board regulators in a module.

MSCs do not have the same functional abilities as the MMSC that mounts in the rack. The controller is located in the upper left section on the front of the module. In a processor compute module, it is between the CD-ROM drive and the hard disk bays.

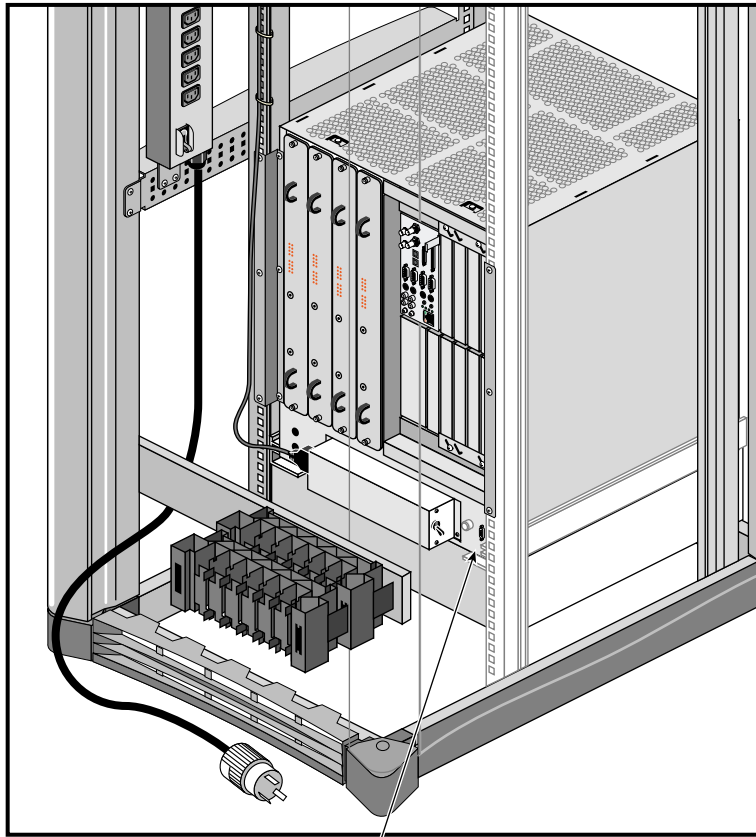
Each MSC provides environmental monitoring for safe operation of the individual modules in the rack. The controller connects to the module's midplane by way of an extender board and provides user access to switches and displays at the front of each module.



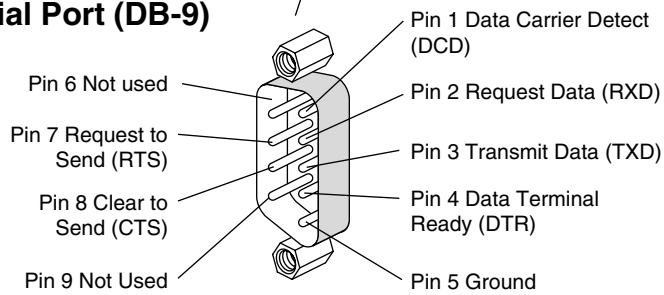
**Figure 6-3** MSC Status Panel and Switches

In the lower right section on the back of each module is a 9-pin serial console connector that is a direct mirror of the 8-pin DIN connector on the front panel.

**Note:** You may not connect serial devices to both the front and rear MSC serial connectors at the same time. The connectors are wired through the same circuitry and cannot accept or send signals through both ports at the same time.



**System Controller  
Serial Port (DB-9)**



**Figure 6-4** MSC Rear Serial Connector

## Understanding the Controller's LEDs and Switches

Each module's MSC has one keyswitch, two pushbuttons, and four LED indicators. Messages displayed on the 8-digit LED panel are described in Table 6-1. The following paragraphs provide information on the use or significance of each control or indicator.

The Front Panel Keyswitch selects **Standby**, **On**, or **Diagnostic** status for the system.

The System **Reset** pushbutton initiates a system-wide reset of the module. The keyswitch must be in the diagnostic position to use this button.

The Non-Maskable Interrupt (**NMI**) switch issues a reset signal to all Node boards in the compute module. The keyswitch must be in the diagnostic position to use this button.

The **AC** Power OK green LED lights when the system is plugged into an outlet and the AC circuit breaker is turned on. The Controller is receiving DC voltage (V\_5 Aux) through the midplane, as are other boards that require it.

The **DC** Power OK green LED lights approximately 3.5 seconds after the keyswitch is turned to the On position. This indicates that the module's power supply is enabled and operating properly.

The Fan Speed **High** amber warning LED lights as an indication that the environmental temperature is higher than optimal, or that a noncritical fan has failed. When a noncritical fan fails, the remaining fans are set at full speed to compensate. When a critical fan fails, the system shuts down. In this case, you see the message MFANFL or FANFAIL on the controller's LED panel. A service call should be placed immediately after confirming that a fan has failed.

The **Over-Temperature Fault** amber warning LED lights when the controller's incoming air temperature or fan failure detection causes a shutdown of the system. If the environmental temperature exceeds the system's tolerance, or if a critical fan fails, the controller shuts down the system. In some cases, a service call should be placed immediately.

### Controller Features and Functions

Each module's controller has a number of basic features and functions. Note the following bulleted items:

- It issues a reset signal at power-on.
- The front-panel mounted keyswitch provides a soft power-off to standby condition.
- A front-panel mounted pushbutton on the controller works as a system reset switch for the module.
- A front-panel mounted pushbutton non-maskable interrupt (NMI) switch on the controller resets all the module's Node boards (applicable to compute modules only).
- It can sense ambient incoming air temperature into a module and adjust fan speed based on that temperature (two speeds). Soft power-off of the module results if ambient temperature is too high for safe operation.
- The controller lights an LED display after sensing ambient over-temperature conditions.
- It has an NVRAM for storing configuration information (1024 x 8 bits).
- The compute module controller monitors fan rotation and automatically increases to high-speed operation when a fan fails. It also signals an impending shutdown when a single critical fan fails, or two or more noncritical fans fail.
- The graphics module has a single blower monitored by the controller. It shuts the module down if the blower fails.
- It has an LED display for high fan (or blower) speed or fan tray failure (fan high-speed LED).

- The controller has an LED display indicator for power supply operations. The AC OK LED indicates AC voltage applied to the module. The DC OK indicates all power supply DC voltages (+12 V, +5 V, +3.45 V) and remote DC voltages (3.3 V, 2.4 V, 1.6 V) are present with no error conditions. The DC OK LED does not indicate regulation or accuracy of the DC voltages present.
- It provides a 100 Kbps bidirectional communication path between the MSC, midplane, and HUB ASIC IO space on each Node board in a compute module. This communication path allows the MSC to receive system status messages from all Node boards in a module, and to provide status messages from the MSC and all Node boards in the module. This communication path is referred to as the I2C interface.
- It provides the ability to request the module serial number and configuration information via the I2C interface.
- The controller has an eight-digit alphanumeric status display. This display is updated by the MSC or the Node board(s) in the system via the I2C interface.
- It provides a seven-wire 9600 Baud alternate console diagnostic port for offline configuration and troubleshooting. This port can also be used to communicate with a compute module's Node boards when the IO console port or graphics console is not functional. This interface also supports the minimum requirements for modem support.
- Software reset, NMI, and soft power-off commands are provided through the alternate console port.
- It supports alternate console port command-line power supply voltage margining. Margining allows the 3.45 V or 5 V outputs of the power supply to be moved 5% higher or lower independently. This does not affect remote regulated termination voltages (1.6 V, 2.4 V, router 3.3 V).
- It has alternate console port command-line regulated termination voltage margining for the termination voltages 1.6 V, 2.4V, and 3.3 V, (all termination voltages are margined 5% higher or lower together, not independently). This does not affect the power supply voltages.

- In a compute module, it sends early warning, high-priority interrupt (Panic Interrupt) to all Node boards warning of an impending shutdown due to an AC power failure, ambient over-temperature, or the keyswitch being turned to the standby position.
- The interlock (removable keyswitch) prevents unauthorized personnel from turning the module on or off, and limits operation of the System Reset and NMI functions. The software password allows access and permissions through the alternate console port.

### MSC Status Messages

The MSC front panel has an eight-character LED readout that supplies information about system status or problems.

Table 6-1 lists status messages and provides an explanation of what the impacts may be.

**Table 6-1** MSC Messages

Error Message	Meaning of Message
SYS OK	The module is operating normally.
R PWR UP	The module is being powered on remotely via the MSC’s serial connection.
POWER UP	The module is being powered on from the front panel switch.
PFW FAIL	The AC power supplied to the module has failed or dropped below acceptable parameters. The module has shut down.
PS OT FL	The module’s power supply temperature has exceeded safety limits and the module has shut down.
PS FAIL	The internal power supply has failed and the module has shut down.
OVR TEMP	The module’s temperature has exceeded acceptable limits and the module has shut down.
KEY OFF	The MSC’s switch has been turned to standby.
RESET	The controller’s switch has been turned to the diagnostic position, and the <b>Reset</b> button pushed.



**Table 6-1 (continued)** MSC Messages

<b>Error Message</b>	<b>Meaning of Message</b>
NMI	The controller's switch has been turned to the diagnostic position, and the non-maskable interrupt ( <b>NMI</b> ) button pushed.
M FAN FL	More than one fan has failed and the module has shut down.
R PWR DN	The module has been powered off from a remote location.
PWR CYCL	The module has received the command to power cycle from the console or a remote user.
HBT TO	The module has registered a heart beat time-out. A non-maskable interrupt is generated, followed by a module reset.
FAN FAIL	A module fan has failed. If it is fan 1, 2, or 3, the module shuts down. A service call should be placed as soon as possible.
POK FAIL	A power OK failure occurred on an unidentified board.



---

## Basic Troubleshooting

This chapter contains hardware-specific information that can be helpful if you are having trouble with your Onyx2 graphics rack system.

It is intended to give you some basic guidelines to help keep your hardware and the software that runs on it in good working order.

### General Guidelines

To keep your system in good running order, follow these guidelines:

- Do not enclose the system in a small, poorly ventilated area (such as a closet), crowd other large objects around it, or drape anything (such as a jacket or blanket) over the system.
- Do not connect cables or add other hardware components while the system is turned on.
- Do not leave either the graphics or compute module front panel key switches in the diagnostic position during normal operation.
- Do not power off the system frequently; leave it running over nights and weekends, if possible. If a system console terminal is installed, it can be powered off when it is not being used.
- Do not place liquids, food, or extremely heavy objects on the system or keyboard.
- Ensure that all cables are plugged in completely.
- Ensure that the system has power surge protection.

## Operating Guidelines

When your system is up and running, follow these operational guidelines:

- Do not turn off power to a system that is currently started up and running software.
- Do not use the root account unless you are performing administrative tasks.
- Make regular backups (weekly for the whole system, nightly for individual users) of all information.
- Keep two sets of backup tapes to ensure the integrity of one set while doing the next backup.
- Protect the root account with a password.
- Check for root UID = 0 accounts (for example, diag) and set passwords for these accounts.
- Consider giving passwords to courtesy accounts such as guest and lp.
- Look for empty password fields in the */etc/passwd* file.

If the behavior of your system is marginal, or faulty, first do a physical inspection using the checklist below. If all of the connections seem solid, go to Chapter 6 and use the System Controllers to try to isolate the problem. If the problem persists, run the diagnostic tests from the System Maintenance menu or PROM Monitor. See the *IRIX Admin: System Configuration and Operation* manual for more information about diagnostic tests.

Check every item on this list:

- The terminal, PDU, and module System Controller (MSC) power switches are turned on.
- The module chassis power switches are all in the On position.
- The fans are running and the fan inlets/outlets are not blocked.
- The multimodule System Controller (MMSC) for display of a fault message or warning.

Before you continue with power and I/O cable checks, shut down the system and turn off the power.

See “Powering Off the System” in Chapter 4 if you are unsure of the complete process for bringing the system down.

Check all of the following cable connections:

- The terminal power cable is securely connected to the terminal at one end and the power source at the other end.
- The power cables are securely connected to the main units at one end or plugged into the proper AC outlet at the other end.
- The Ethernet cable is connected to the connector port labeled **Ethernet**.
- Serial port cables are plugged in securely to their corresponding connectors.
- All cable routing is safe from foot traffic.

If you find any problems with hardware connections, have them corrected before you restore power to the system. The MMSC may help to determine if internal system problems exist.

If these procedures do not help, contact your system administrator or service provider.

## Module Power Supply Problems

The module power supplies in your graphics rack system are not considered end-user replaceable components. There are certain basic checks you can make to determine if a system problem is related directly to a module power supply.

If the module does not power on at all, check the following:

- Confirm that the module's circuit breaker is up (in the On position).
- Check to make sure the power cable is firmly plugged in at both the system connector and the wall socket.
- Remove the plastic front cover (facade) and confirm that the cable connecting the power supply to the fan tray is secure.

In some cases the module's power supply may be unable to supply enough voltage to meet system requirements. If the MSC indicates a power supply related problem, you can remove the front cover and check the status of the three LEDs on the front of the power supply. For help on properly removing the front cover, see "Removing a Module's Facade" in Chapter 5.

### **Amber (Yellow) LED**

The amber LED on the power supply (also known as the AC\_OK indicator) lights when the AC input voltage is applied and the system circuit breaker is in the On position.

If the amber LED is not lit, check the following:

- AC outlets
- system power cords and power switch
- fan tray to power supply cable

If none of these items is a problem, check the other LEDs on the power supply for any indications.

### **Green LED**

The green LED indicator (also known as the Power Good indicator) lights when power supply outputs are within specification.

If this LED starts to blink on and off, it is a warning that the supply is overloaded. In this case, contact your service provider for information and assistance.

### **Red LED**

The red LED (also known as the Fault indicator) lights up whenever the power supply shuts off because of insufficient air flow, or when a system over-temperature shutdown occurs.

A blinking condition on this LED indicates that an undervoltage condition exists. It means that the supply has dropped below acceptable limits in either the +3.45, +5, or +12 volt ranges. The supply can be reset by power-cycling the system. Note that this could be a symptom of other problems; contact your service provider for additional information.

## Crash Recovery

To minimize data loss from a system crash, back up your system daily and verify the backups. Often a graceful recovery from a crash depends upon good backups.

Your system may have crashed if it fails to boot or respond normally to input devices such as the keyboard. The most common form of system crash is terminal lockup—your system fails to accept any commands from the keyboard. Sometimes when a system crashes, data is damaged or lost.

Before going through a crash recovery process, check your terminal configuration and cable connections. If everything is in order, try accessing the system remotely from another workstation or from the system console terminal (if present).

If none of the solutions in the previous paragraphs is successful, you can fix most problems that occur when a system crashes by using the methods described in the following paragraphs. You can prevent additional problems by recovering your system properly after a crash.

The following list presents several ways to recover your system from a crash. The simplest method, rebooting the system, is presented first. If that fails, go on to the next method, and so on. Here is an overview of the different crash recovery methods:

### Rebooting the System

Rebooting usually fixes problems associated with a simple system crash.

### Restoring System Software

If you do not find a simple hardware connection problem and you cannot reboot the system, a system file might be damaged or missing. In this case, you need to copy system files from the installation tapes to your hard disk. Some site-specific information might be lost.

## Restoring from Backup Tapes

If restoring system software fails to recover your system fully, you must restore from backup tapes. Complete and recent backup tapes contain copies of important files. Some user- and site-specific information might be lost. Read the following section for information on file restoration.

## Restoring a Filesystem From the System Maintenance Menu

If your root filesystem is damaged and your system cannot boot, you can restore your system from the Recover System option on the System Maintenance Menu. This is the menu that appears when you interrupt the boot sequence before the operating system takes over the system. To perform this recovery, you need two things:

- Access to a CD that contains the IRIX release on your system.
- A full system backup tape (beginning in the root directory (/) and containing all the files and directories on your system) created using the Backup and Restore Manager.

If you do not have a full system backup made with the *Backup* command or Backup and Restore window—and your *root* or *usr* filesystems are so badly damaged that the operating system cannot boot—you have to reinstall your system software and then read your backup tapes (made with any backup tool you prefer) over the freshly installed software.

You may also be able to restore filesystems from the miniroot. For example, if your root filesystem has been corrupted, you may be able to boot the miniroot, unmount the root filesystem, and then use the miniroot versions of *restore*, *xfs\_restore*, *Restore*, *bru*, *cpio*, or *tar* to restore your root filesystem.



To recover from system corruption using the Recover System option on the System Maintenance Menu, follow these steps:

1. When you first start up your machine or press the Reset button on the system, this message appears:

```
Starting up the system...
```

Click the *Stop for Maintenance* button or press **Esc** to bring up the System Maintenance menu.

2. Click the Recover System icon in the System Maintenance menu, or type **4**.

This System Recovery menu appears or you see a graphical equivalent:

```
System Recovery...
```

```
Press <Esc> to return to the menu.
```

```
1) Remote Tape  2) Remote Directory  3) Local CD-ROM  4) Local Tape
```

```
Enter 1-4 to select source type, <esc> to quit,  
or <enter> to start:
```

3. Enter the menu item number or click the appropriate drive icon for the IRIX release CD or software distribution directory you plan to use.

**Note:** As of IRIX 6.2, the Remote Tape and Local Tape options on the System Recovery window are no longer usable because bootable (miniroot) software distribution tapes are no longer supported.

- If you have a CD-ROM drive connected to your system, enter **3** or click the *Local CD-ROM* icon, then click *Accept* to start.

You then see a notifier prompting you to insert the media into the drive. Insert the IRIX CD that came with your system, then click *Continue*.

- You can use a drive that is connected to another system on the network. At the System Recovery menu, enter **2** or click the *Remote Directory* icon.

When a notifier appears asking you for the remote hostname, type the system's name, a colon (:), and the full pathname of the CD-ROM drive, followed by */dist*. For example, to access a CD-ROM drive on the system *mars*, you would type:

```
mars:/CDROM/dist
```

Click *Accept* on the notifier window, then click *Accept* on the System Recovery window.

On systems without graphics, you are prompted for the host as above, then you see this menu:

- 1) Remote Tape 2) [Remote Directory] 3) Local CD-ROM 4) Local Tape
- \*a) Remote directory /CDROM/dist from server mars.

Enter 1-4 to select source type, a to select the source, <esc> to quit, or <enter> to start:

Press Enter.

- If you are using a remote software distribution directory, enter 2 or click the *Remote Directory* icon.

When a notifier appears that asks you to enter the name of the remote host, type the system's name, a colon (:), and the full pathname of the software distribution directory. For example:

**mars:/dist/6.2**

Click *Accept* on the notifier window, then click *Accept* on the System Recovery window.

On systems without graphics, you are prompted for the host as above, then you see this menu:

- 1) Remote Tape 2) [Remote Directory] 3) Local CD-ROM 4) Local Tape
- \*a) Remote directory /dist/6.2 from server mars.

Enter 1-4 to select source type, a to select the source, <esc> to quit, or <enter> to start:

Press Enter.

4. The system begins reading recovery and installation from the CD. It takes approximately five minutes to copy the information that it needs. After everything is copied from the CD or remote directory to the system disk you see messages including:

```
*****
*
*                      CRASH    RECOVERY
*
*
*****
```

You may type `sh` to get a shell prompt at most questions

Checking for tape devices

The next message asks for the location of the tape drive that you will use to read a system backup tape you created prior to the system crash using the Backup and Restore tool on the System menu of the System Toolchest or using the Backup(1) script.

5. If you have a local tape device, you see this message:

```
Restore will be from tapename. OK? ([y]es, [n]o): [y]
```

*tapename* is the name of the local tape device. Answer **y** if this is the correct tape drive and **n** if is not.

6. If you have a remote (network) tape device, no tape device was found, or you answered “no” to the question in the previous step, you see this message:

```
Remote or local restore ([r]emote, [l]ocal): [l]
```

- If you answer “remote,” you have chosen to restore from the network, and you are then asked to enter the following information: the hostname of the remote system, the name of the tape device on the remote system, the IP address of the remote system, and the IP address of your system. The IP address must consist of two to four numbers, separated by periods, such as 192.0.2.1
- If you answer “local,” you have chosen a tape device that is connected to your system, and you are then asked to enter the name of the tape device.

7. When you see the following message, insert your most recent full backup tape, then press Enter.

```
Insert the first Backup tape in the drive, then
press (<enter>, [q]uit (from recovery), [r]estart):
```

8. There is a pause while the program identifies the filesystems on the tape and attempts to mount those filesystems under */root*. Then you see this message:

```
Erase all old filesystems and make new ones (y, n, sh): [n]
```

You have three choices:

- Answer **n** for no. After additional prompts confirming the filesystems to be read, the files on the tape are extracted. The version of each file on the tape replaces the version, if any, on the disk even if the version on the disk is newer.
  - Answer **y** for yes. After additional confirming prompts and prompts about filesystem types, the system erases all of the filesystems and copies everything from your backup tape to the disk.
  - Answer **sh** to escape to a shell. You are now in the miniroot environment and can investigate the damage to the system or attempt to save files that have been created or modified since the backup tape was created. After exiting the shell, you have the opportunity to remake filesystems and/or read the backup tape.
9. After reading the full backup tape, this prompt gives you the opportunity to read incremental backup tapes:

```
Do you have incremental backup tapes to restore ([y]es, [n]o
(none)): [n]
```

Insert another tape and answer **y** if you have additional tape, answer **n** otherwise.

10. This prompt gives you the opportunity to reboot your system if recovery is complete, begin the crash recovery process again at the beginning, or re-read your first backup tape:

```
Reboot, start over, or first tape again? ([r]eboot, [s]tart,
[f]irst) [r]
```

If you are ready to reboot, answer **r**, otherwise choose **start** or **first**.

From time to time you may experience a system crash due to file corruption. Systems cease operating (“crash”) for a variety of reasons. Most common are software crashes, followed by power failures of some sort, and least common are actual hardware failures. Regardless of the type of system crash, if your system files are lost or corrupted, you may need to recover your system from backups to its pre-crash configuration.

Once you repair or replace any damaged hardware, you are ready to recover the system. Regardless of the nature of your crash, you should reference the information in the section “Restoring a Filesystem from the System Maintenance Menu” in the *IRIX Admin: Backup, Security, and Accounting* manual.

The System Maintenance Menu recovery command is designed for use as a full backup system recovery. After you have done a full restore from your last complete backup, you may restore newer files from incremental backups at your convenience. This command is designed to be used with archives made using the Backup(1) utility or through the System Manager. The System Manager is described in detail in the *Personal System Administration Guide*. System recovery from the System Maintenance Menu is not intended for use with the *tar(1)*, *cpio(1)*, *dd(1)*, or *dump(1)* utilities. You can use these other utilities after you have recovered your system.

You may also be able to restore filesystems from the miniroot. For example, if your root filesystem has been corrupted, you may be able to boot the miniroot, unmount the root filesystem, and then use the miniroot version of *restore*, *xfs\_restore*, *bru*, *cpio*, or *tar* to restore your root filesystem. Refer to the reference (man) pages on these commands for details on their application.

Refer to the *IRIX Admin: System Configuration and Operation* manual for instructions on good general system administration practices.



---

## System Specifications

Table A-1 and Table A-2 provide technical specifications for the Onyx2 rack system.

**Table A-1** Physical and Environmental Specifications

Parameter		Specification
Dimensions:		
Installed:	length	39" (99 cm)
	width	29" (74 cm)
	height	73" (185 cm)
Shipping:	length	81" (206 cm)
	width	47" (120 cm)
	height	49" (125 cm)
Weight:	minimum (empty rack)	300 lbs (136 kg)
	maximum (full rack)	750 lbs (340 kg)
	shipping (maximum)	900 lbs (408 kg)
Floor Loading:	minimum	38 lb/ft <sup>2</sup> (185 kg/m <sup>2</sup> )
	maximum	95 lb/ft <sup>2</sup> (466 kg/m <sup>2</sup> )
Air Temperature:	operating (< 5000 ft)	41° to 95° F (5° to 35° C)
	operating (> 5000 ft)	41° to 86° F (5° to 30° C)
	non-operating	-4° to 140° F (-20° to 60° C)
Thermal Gradient:	maximum	18° F (10° C) per hour
Altitude:	operating	10,000 ft (3,048 m) MSL, maximum
	non-operating	40,000 ft (12,192 m) MSL, maximum

**Table A-2** Electrical and Cooling Specifications

<b>Parameter</b>		<b>Specification</b>
Voltage:		187-264 Volts, 1-phase
Watts (from-the-wall):	maximum	5750 watts
Power Factor:	minimum	0.98
Inrush Current:	maximum	400
Frequency:		47-63 Hertz
Heat Output:	maximum	19,550 Btu/hr (1.63 ton AC load)



## Drive Maintenance

This appendix describes the preventive maintenance required for systems having 1/4-inch tape drives, 4-mm DAT and 8-mm tape drives, as well as CD-ROM drives.

### Cleaning the 4-mm DAT and 8-mm Tape Drives

These are the manufacturers' recommended cleaning schedules:

- Clean the 4-mm DAT drive every 25 hours of use.
- Clean the 8-mm tape drive once every 30 GB of data transferred, or after 15 passes.

**Note:** When the drive heads are dirty and need cleaning, the units may exhibit either read or write errors.

Use only an approved cleaning kit when cleaning the drives. You can use a cleaning kit a limited number of times before you must replace it. For example, you can use the 4-mm drive cleaning kit approximately 60 times; however, you can use the 8-mm drive cleaning cartridge only 12 times. Refer to the information supplied with the cleaning kit to determine the replacement interval. Do not use cleaning kits that are intended for use in audio DAT units, since these cassettes are not recognized by the drives covered in this guide.

## 4-mm DAT Drive

The 4-mm DAT drive provides data storage on 60-, 90-, and 120-meter digital data storage (DDS) DAT cassettes. The drive complies with the American National Standards Institute (ANSI) DDS and DDS-2 formats and uses a small DAT with 4-mm tape. The data transfer rate is 183 KB per second. Note that these capacity and transfer rate figures are approximate.

### Loading and Unloading Cassettes

Insert the cassette so that the arrow on the top of the cassette enters the drive first. To load a cassette, insert it into the drive and push gently on the middle of the cassette until the tape is fully recessed in the drive unit.

When you load a tape into the drive, the unit checks to see if the tape is initialized. This checking process takes between 10 and 20 seconds. If the tape has never been initialized, the drive will initialize it when you first start to write data to the tape. Initializing the tape takes an extra 30 seconds beyond what is required to write the data.

**Note:** Do not remove the tape from the drive while it is being initialized.

To remove a cassette, press the unload button on the face of the drive. The unit automatically rewinds the tape and ejects it partway. Grasp the cassette and remove it from the drive. Note that the unload button is disabled when the drive is in use.

### Removing a Jammed 4-mm Cassette

To remove a 4-mm tape that has jammed in the drive, follow these steps:

1. Power-cycle the tape drive and then try ejecting it.
2. If that does not eject the drive, power-cycle it while holding down the unload button.

If neither of these two steps ejects the jammed cassette, contact your service provider.

## Cleaning the 4-mm DAT Drive

**Note:** Every time you use the cleaning cassette, the drive uses a new, unused portion of the tape. After about 30 uses, the tape is used up and you must obtain a new one. Always note the number of times you use each cleaning cassette. Never use an audio DAT cleaning cartridge in your DDS-2 drive.

Using only a DDS-qualified DAT drive cleaning cassette:

1. Insert the cleaning cartridge into the drive. The drive automatically detects that the cassette is a cleaning cassette, then loads and runs the cassette. After about 10 to 15 seconds, the cleaning is complete and the drive ejects the cassette.
2. Remove the cleaning cassette from the drive and make a note, either in a log book or on the cassette itself, that you used the cleaning kit.

## Front Panel Lights

The 4-mm drive has two LEDs, one green and one yellow, that indicate the status of the unit (see Table B-1).

**Table B-1** 4-mm DAT Front Panel LED Status Indicators

LED	Action	Meaning
Yellow	On (lit)	The drive is reading or writing the tape (normal operation).
Yellow	Flashing Rapidly	A hardware fault occurred or condensation was detected in the unit (error).
Green	On (lit)	A cassette is loaded in the drive and it does not generate excess errors (beyond a predefined error threshold): this is normal operation.
Green	Flashing Slowly	A cassette is inserted, but is generating excess soft errors (warning: heads may need cleaning).
Green	Flashing Slowly with Yellow LED	A prerecorded audio cassette is inserted and is being played automatically.
Green	Flashing Rapidly	The drive cannot write the tape correctly (error). Clean the heads or confirm tape is writable.

## Care and Cleaning of the Exabyte 8-mm Tape Drive

Cleaning the tape drive requires use of an EXABYTE™ 8-mm cleaning cartridge or one approved by Exabyte.

**Caution:** Use of cleaning materials not approved by Exabyte may void the tape drive's warranty.

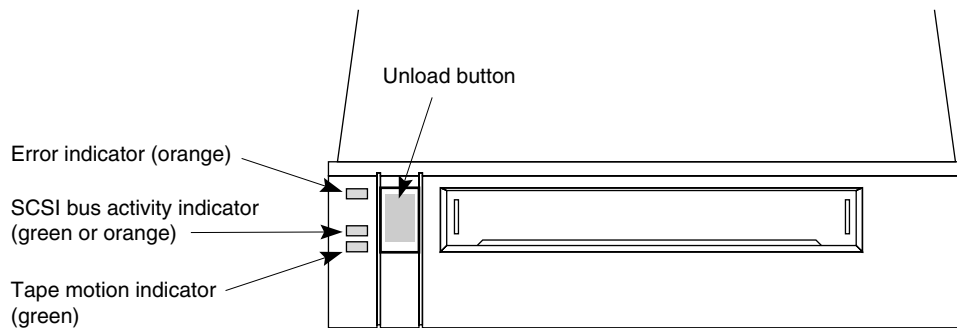
To clean the tape drive:

1. Check to see if an 8-mm tape cartridge is present in the drive. If so, press the unload button and remove the cartridge. Leave the drive's door open.
2. Insert the Exabyte or Exabyte-compatible cleaning cartridge and close the drive. The tape drive automatically runs through the 15-second cleaning cycle. The tape ejects automatically when cleaning is complete.

**Note:** If the cleaning cartridge is ejected from the drive before the 15-second cleaning cycle ends, the cartridge has reached the maximum number of cleaning cycles and should be discarded. Do not rewind the cleaning cartridge or use it for more than its specified number of cleaning cycles. Remove the cartridge, record the date on the label, and store it for future use.

### Front Panel Lights

The 8-mm tape drive has three front panel lights (see Figure B-1).



**Figure B-1** 8-mm Tape Drive Front Panel

Table B-2 shows a specific combination of LEDs that may occur during tape drive operation and the tape drive states that they indicate.

**Table B-2** LED States and Interpretations

LED State	Top LED (errors)	Middle LED (SCSI)	Bottom LED (motion)
Self-test start	On	On (green)	On
Self-test end	On	Flashing (irregularly)	Off
Self-test fails	Flashing (fast)	Flashing (irregularly)	Off
Ready (no tape)	Off	Flashing (irregularly)	Off
Ready (tape)	Off	Flashing (irregularly)	On
Normal tape motion	Off	Flashing (irregularly)	Flashing (slowly)
High-speed tape motion	Off	Flashing (irregularly)	Flashing (fast)
SCSI bus reset	On	Flashing (irregularly)	On
Error	Flashing (slowly)	Flashing (irregularly)	Off
Time to clean	Flashing (fast)	Flashing (irregularly)	Flashing (fast)

### Removing a Jammed 8-mm Tape Cartridge

To remove a tape that has jammed in an 8-mm tape drive, follow these steps:

1. Power-cycle the tape drive and then try ejecting it.
2. If that does not eject the drive, power-cycle it while holding down the unload button.

If neither of these steps ejects the cartridge, contact your service provider.

## CD-ROM Care and Maintenance

CD-ROM drives are most vulnerable to damage when they are unpacked and not yet mounted in a computer system. When handling a drive after unpacking, there are two major types of damage to be aware of:

- rough handling (impact damage)
- electrostatic discharge (ESD)

Dropping an unpacked drive onto a hard surface can cause damage. A sharp jolt can cause the laser to track improperly.

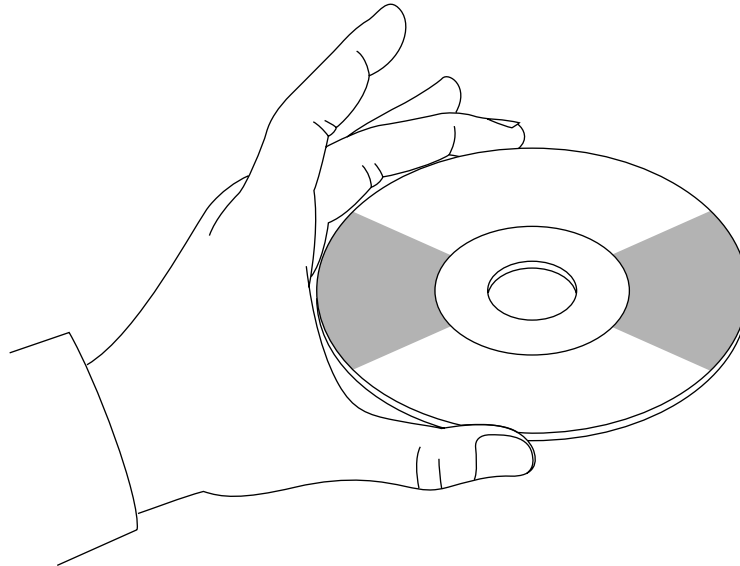
Avoid touching the drive's printed circuit board (PCB). Leave the unit in ESD protective wrap as long as possible. Use a static-conductive mat and or antistatic grounding devices when inspecting or handling the drive. Additional handling tips are given below:

1. Keep the drive in the packing box or antistatic bag until the installation.
2. Handle the drive by its frame; avoid touching the drive's PCB.
3. Install drives in a clean work area.
4. Wear a properly grounded ESD strap when handling the drive.

To remove dust or other particles from a CD, use compressed air. You may also clean the CD in running water and then blot it dry with a soft lintless cloth (do *not* use a paper towel). Wipe the cloth directly outward from the center of the disc. Do not rub in a circular motion as you would with a standard phonograph record.

**Caution:** Do *not* use solvents or other common cleaners, and *do not* use your mouth to blow dust or other particles off the disc.

Individual discs should be handled by the edges only (see Figure B-2). Touching or scratching the bottom of the disc can mar the finish and degrade the optical readability of the media. Do not write, label, or mark on any surface of the compact disc. An auto-eject occurs when you insert a very dirty or badly scratched disc (or a disc placed label-side down in the drive).



**Figure B-2** Handling a Compact Disc

### **CD-ROM Environmental Considerations**

Bringing a disc from a cold to a warm environment may cause moisture to form on its surface. Wipe any condensed moisture off with a soft lint-free cloth (not a paper towel) before use. Allow approximately one hour for the disc to acclimate to room temperature.

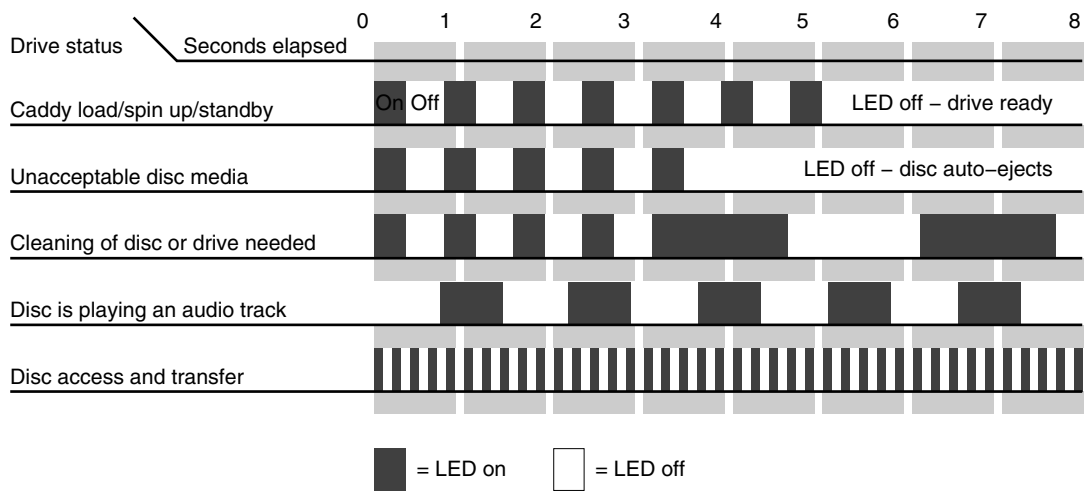
Protect the discs from dust, scratches, and warping by storing them in a plastic storage container (known as a jewel case). Never leave or store discs in the following areas:

- locations exposed to direct sunlight
- dusty and/or humid environments
- areas directly exposed to heating appliances or heat outlets
- a vehicle parked in the sun

### CD-ROM Front Panel Operational Features

A number of operational items are located on the drive's front panel:

- The *headphone jack* receptacle accepts a 3.5-mm diameter stereo plug.
- The *volume control dial* is located to the right of the headphone jack. Use it to adjust the sound level of the drive.
- A *drive busy indicator LED* is located to the left of the eject button. When this LED is blinking, it indicates drive activity. The LED stays dark when no disc is loaded in the drive. See Figure B-3 for details on blink patterns and the status they indicate for the drive.
- The *eject button* is located at the right side of the front panel. It works *only* when the CD-ROM drive is powered on. The disc drawer (caddy) will not eject if the CD-ROM is in an active (busy) state. After pushing the eject button, two to three seconds will elapse before release occurs.
- An *emergency eject hole* is located at the far right of the drive. It is used to eject the CD when the normal procedure does not work. Insert the end of a large, straightened paper clip into the hole until the caddy drawer slides out.



**Figure B-3** CD-ROM Drive LED Status Indicators



## Quarter-Inch Cartridge Tape Drive Preventive Maintenance

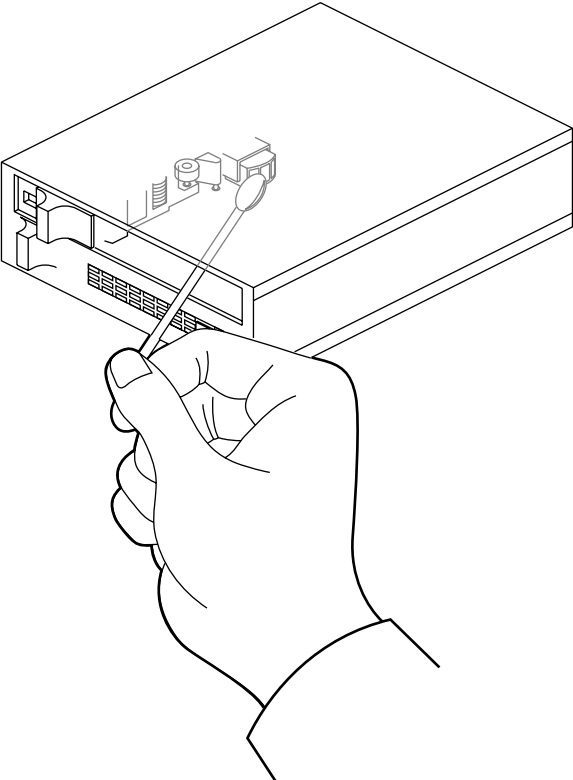
Head cleaning is the only preventive maintenance required by the 1/4-inch tape drive. The tape head should be cleaned after every eight hours of tape drive operation and after every two hours of operation when new tapes are used exclusively.

**Note:** The head cleaning procedure must be routinely done after every two to eight hours of operation to ensure proper tape drive functions.

Clean the tape head by following these steps:

1. Remove the tape cartridge from the tape drive.
2. Push the head loading lever to the right, as if you had installed a tape. This engages the tape head, allowing you to reach it.
3. Dip a clean, non-fibrous cotton swab in tape head cleaning fluid and wipe the tape head (see Figure B-4).
4. Use a second, clean swab and wipe the head again, to remove any residue.

**Caution:** Do not use cotton swabs that have wooden stems. The tip of the swab can break off and become lodged in the tape drive.



**Figure B-4** Tape Head Cleaning

---

## Module System Controller Messages

A complete list of all of the possible module System Controller messages is provided in Table C-1.

**Table C-1** MSC Alpha-Numeric Display Messages

MSC Message	Meaning
CHK INV	The current system configuration is different than the stored hardware inventory. Run "update" to eliminate this message.
FAN FAIL	A system fan has failed. If it is fan 1, 2, or 3, the system shuts down. A service call should be placed as soon as possible.
HBT TO	The system has registered a heart beat time-out. A non-maskable interrupt is generated, followed by a system reset.
KEY OFF	The MSC keyswitch has been turned to standby.
M FAN FL	More than one fan has failed and the system has shut down.
NMI	The MSC keyswitch has been turned to the diagnostic position, and the non-maskable interrupt (NMI) button has been pushed.
OVR TEMP	The system's temperature has exceeded acceptable limits and the system has shut down.
PFW FAIL	The power supplied to the system has failed or dropped below acceptable parameters. The system has shut down.
POK FAIL	A power OK failure occurred on an unidentified board.
POWER UP	The system is being powered on from the front panel switch.
PS OT FL	The system's power supply temperature has exceeded safety limits and the system has shut down.
PS FAIL	The internal power supply has failed and the system has shut down.
PWR CYCL	The MSC has received the command to power cycle from the console or a remote user.

**Table C-1 (continued)** MSC Alpha-Numeric Display Messages

<b>MSC Message</b>	<b>Meaning</b>
R PWR DN	The system is being powered off remotely via the MSC serial connection (typically by an MMSC).
R PWR UP	The system is being powered on remotely via the MSC serial connection (typically by an MMSC).
RESET	The MSC keyswitch has been turned to the diagnostic position, and the reset button has been pushed.
SYS OK	The system is operating normally.

---

## Video Format Combiner Tutorial

This appendix consists of example exercises designed to demonstrate tasks you can perform using the video combiner utility with your InfiniteReality graphics system. It includes:

- modifying video formats
- saving video format combinations to the GE board's EEPROM
- resizing a single-channel combination
- using ircombine with GVO

This appendix also includes instructions for redisplaying graphics if the monitor should stop displaying video during one of the examples (or at any other time).

The information in this appendix is intended only as an introductory overview of the Combiner. For more detailed information on using the Combiner with your Onyx2 graphics system, see the *InfiniteReality Video Format Combiner User's Guide* (P/N 007-3279-*nnn*).

### Reinitializing Graphics

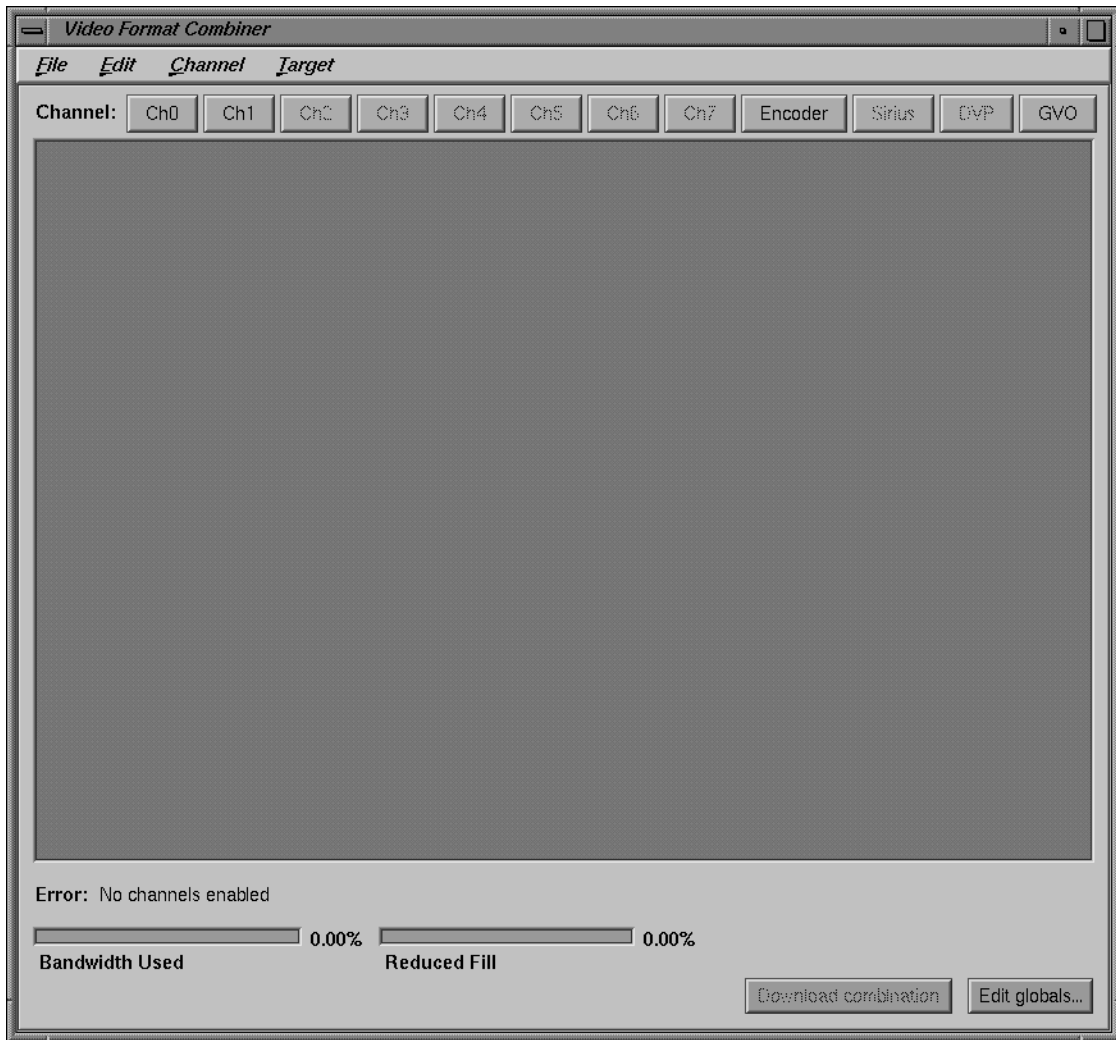
The example exercises in this appendix are based on the assumption that a Silicon Graphics multisync monitor is connected to Channel 0. If the monitor attached to Channel 0 is unable to sync to any of the formats used in the example, it ceases displaying video.

The first time InfiniteReality graphics was initialized, or during the first power-on of the system with InfiniteReality graphics installed, the video output was defined for the channels available on the workstation. To reinitialize graphics, enter

```
(/usr/gfx/stopgfx ; /usr/gfx/startgfx) &
```

at the IRIX prompt. Note that the parentheses are necessary.

Figure D-1 shows an example of the main window interface.



**Figure D-1** Combiner Main Window

Each example starts from the Combiner's main window.

## Modifying Video Formats

This exercise consists of

- performing steps to avoid a reboot
- selecting a video format for Channel 0
- selecting a video format for Channel 1

Each procedure is explained in a separate section.

### Performing Steps to Avoid a Reboot

Before modifying and downloading new video format combinations, you can avoid having to reboot the graphics system if you select a combination of window sizes that do not encompass the Combiner main window controls or an IRIX shell window. Follow these steps:

1. Bring up an IRIX shell window and reduce it to 80 x 24 using the size option on the pulldown menu from mouse button three.
2. Drag the IRIX shell to the lower left corner of the screen.
3. Launch the Combiner main window (if you have not already done so).
4. Position the Combiner's main window in the upper left corner of the screen.
5. Resize the Combiner's main window so that none of the IRIX shell window is covered: click the lower right corner of the Combiner main window and move it upward.

Figure D-2 shows the main window with Channels 0 and 1 in the managed area.

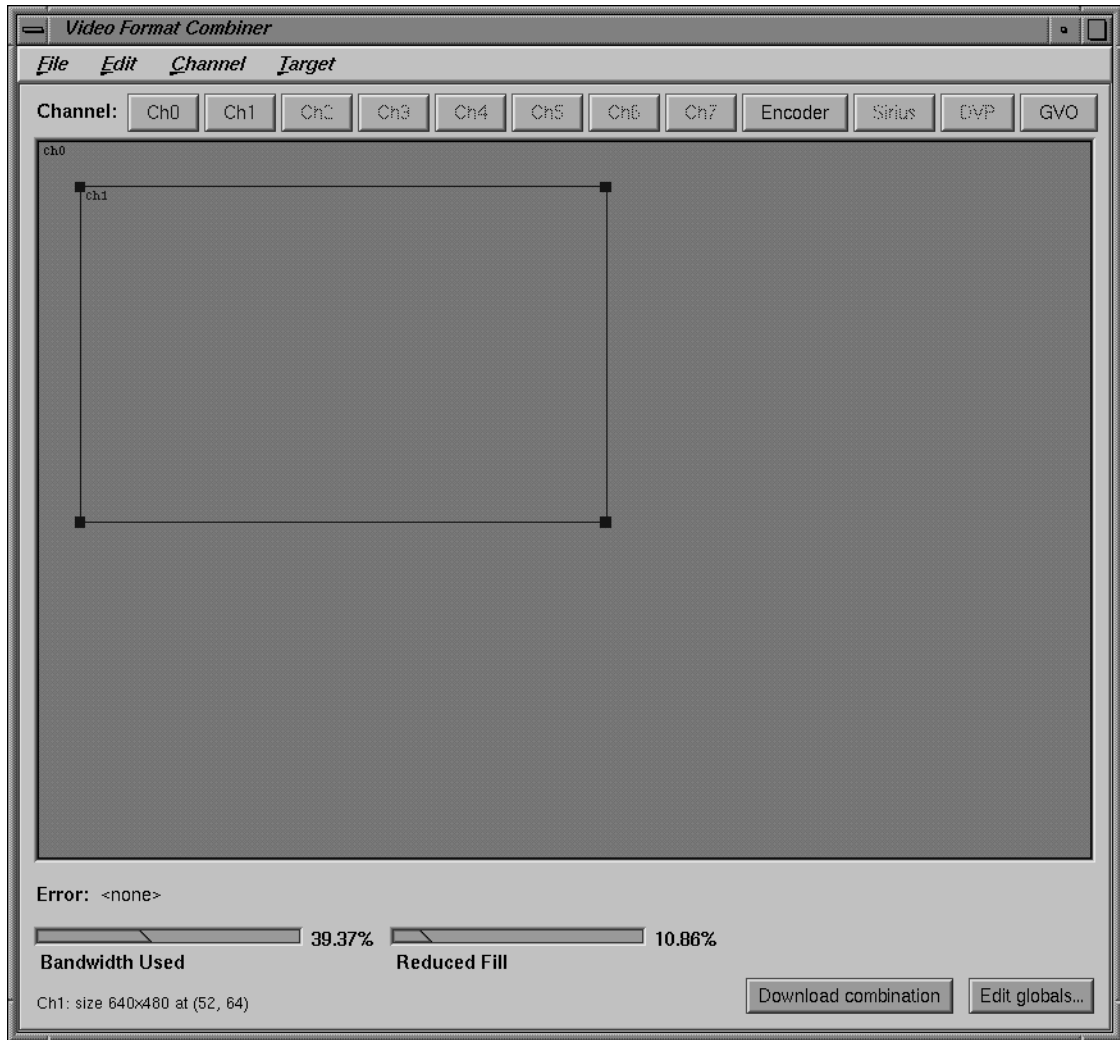


Figure D-2 Combiner Main Window With Channels Selected



## Selecting a Video Format for Channel 0

To select the first channel to modify (Channel 0), follow these steps:

1. Click *Ch0* in the Combiner main window. This selection corresponds to **Chan0** connections on the InfiniteReality system's I/O panel.
2. In the Files window that appears, select the *640x480\_60.vfo* file as the video format for that channel; see Figure D-3.



**Figure D-3** Selecting a Channel Format

3. Click *OK*. The *Ch0* rectangle appears in the Combiner's main window. Do not close the Files window.
4. Click on the bottom line (not the corner) of the rectangle and drag it to the bottom left corner of the main window.

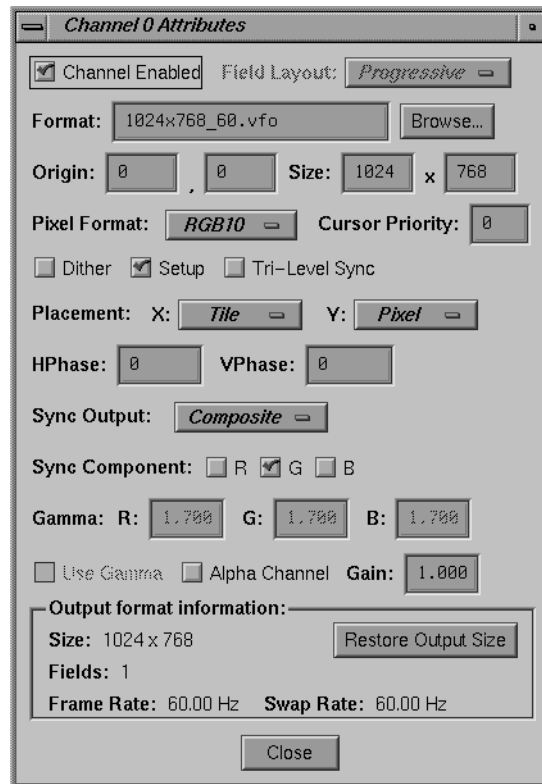
### Selecting a Video Format for Channel 1

Select and modify Channel 1 using the following steps:

1. Click *Ch1* on the main window.
2. Move the cursor to the Files window and click the *640x480\_60.vfo* file option.
3. Click *OK*. A Channel 1 (Ch1) rectangle appears in the upper left portion of the Combiner main window.

**Note:** In this example, you set the origin of Channel 1 precisely to (4,10). You could do this by clicking on the line of the rectangle and dragging it, as you did for Channel 0. However, in this exercise you specify the Ch1 origin numerically by editing the Ch1 attributes in the following steps.

4. Bring up the Attributes window by double-clicking the *Ch1* button in the Combiner main window. The Channel 1 Attributes window appears, as shown in Figure D-4.



**Figure D-4** Channel Attributes Window

5. Click the cursor in the first (far left) Origin box.
6. Replace the value in the left Origin box (the x-origin box) with **4**; press Enter.
7. Move to the right Origin box (the y-origin box) and replace the value with **10**; press Enter. See Figure D-4 for an example.
8. Click *Close* in the Attributes window.
9. Move the cursor to the Combiner main window and click *Download combination*.

At this point, the video system is displaying the configuration specified in the exercise just completed:

- Channel 0 is displaying the lower left portion of the frame buffer where you originally placed the IRIX shell window.
- Channel 1 is displaying the upper left portion of the frame buffer where the InfiniteReality Combiner's main window was placed.

To return to a 1280 x 1024 video output, enter `/usr/gfx/setmon -n 1280x1024_72` in the IRIX shell window.

Go on to the next example or close the Combiner's main window.

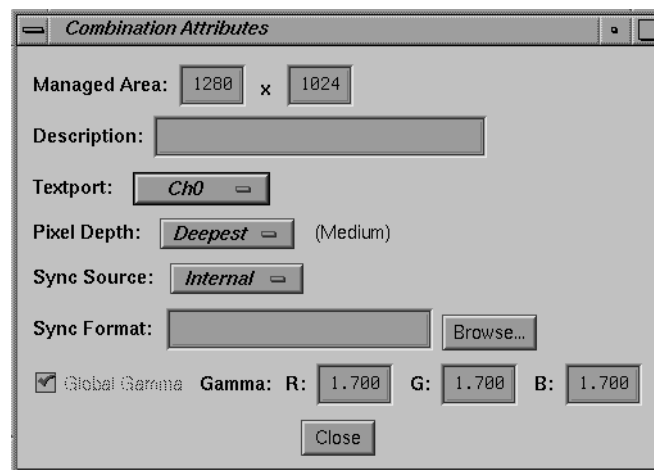
## **Saving Video Format Combinations to the GE Board's EEPROM**

Before starting this exercise, be sure to read the information in "Reinitializing Graphics" on page 159.

This example assumes that the Combiner main window is open. If it is not, follow the instructions at the beginning of this appendix.

In the Combiner main window, select "New" from the File pulldown menu. Then click *OK* in the warning box. You are now ready to create and save a new video format combination to the GE board's EEPROM. The video format consists of two channels; each one is a *960x680\_60.vfo* format. Use the following steps to make and save all the changes:

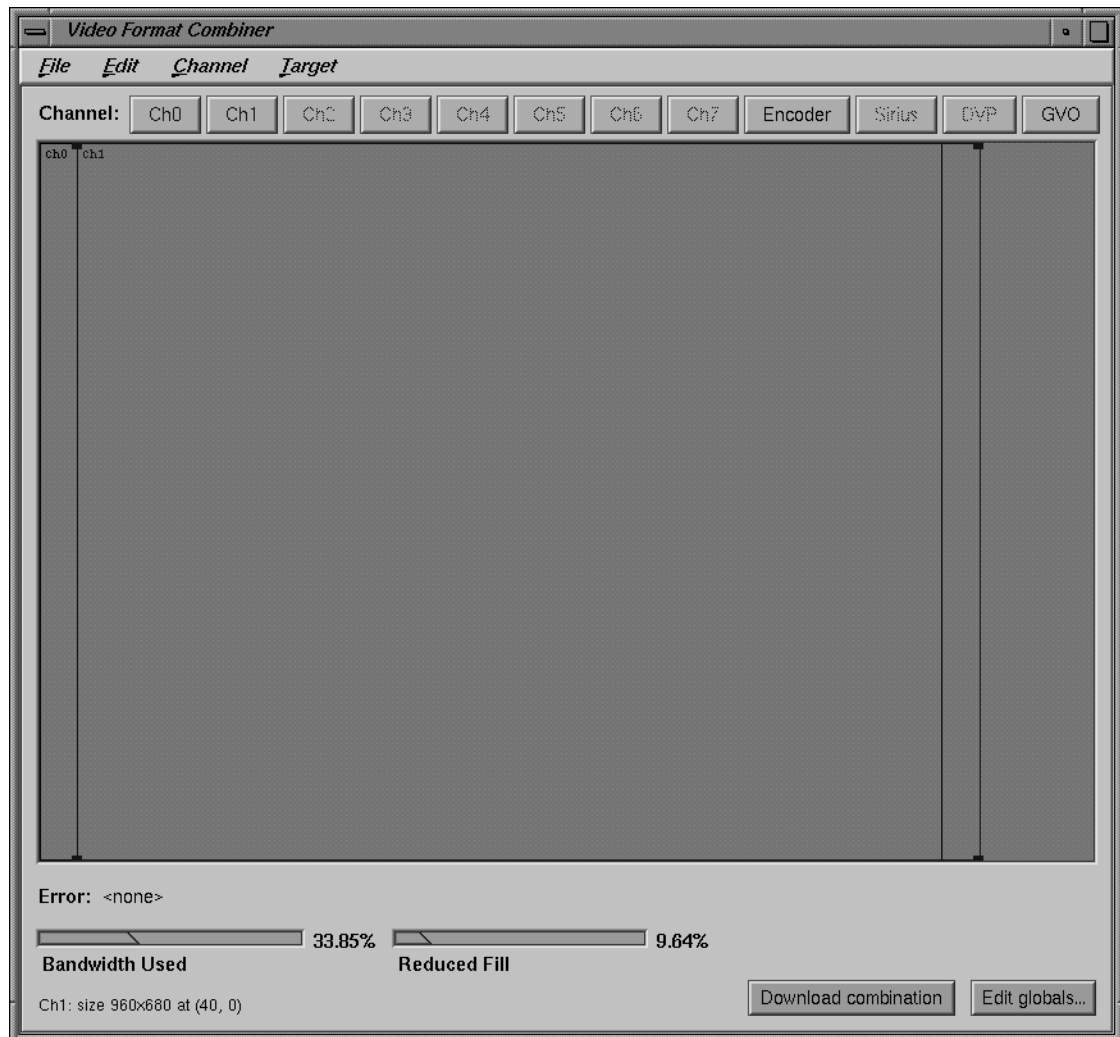
1. Click *Edit globals* in the main window's bottom right corner. The Combination Attributes window appears, as shown in Figure D-5.



**Figure D-5** Combination Attributes Window

2. Change the Managed Area fields at the top of the Attributes window to read 1000 in the left-hand box and 680 in the right-hand box.
3. Click the Attributes window's *Close* button.
4. Click *Ch1* in the Combiner's main window. The Select Format box appears.

5. Find and double-click the *960x680\_60.vfo* file format. An error message appears at the lower left corner of the Combiner's main window, as shown in Figure D-6: "Textport channel Ch0 invalid."



**Figure D-6** Textport Error Message on the Main Window

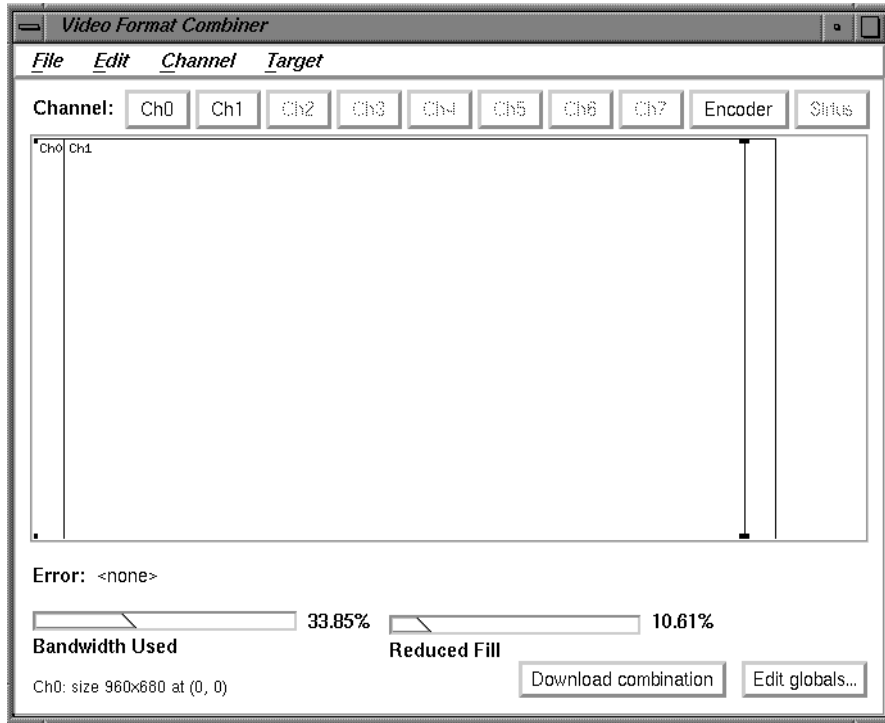
When this or any other error message appears in the main window, you cannot use the "Download combination" or "Save to EEPROM" functions. In this example, the error condition goes away after you define Ch0.

6. Click and drag the Channel 1 (Ch1) box on the main window to the right until it is blocked by the red vertical line.

The red line represents the right-hand boundary of the specified Managed Area (1000) that you entered in step 2. The excess space to the right of the red line represents an unusable area. The Combiner does not permit you to position channels in that area.

7. Click *Ch0* in the Combiner main window.
8. In the Select Formats box that appears, find and double-click the *960x680\_60.vfo* file format.

At this point, you have specified a video format combination with two video formats that are both equal to 960x680\_60. The two channels are slightly offset but mostly overlapping, as shown in Figure D-7.

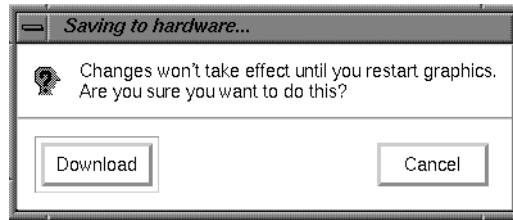


**Figure D-7** Combiner Main Window With Overlapping Channels

9. In the File pulldown menu in the Combiner's main window, select "Save to EEPROM."



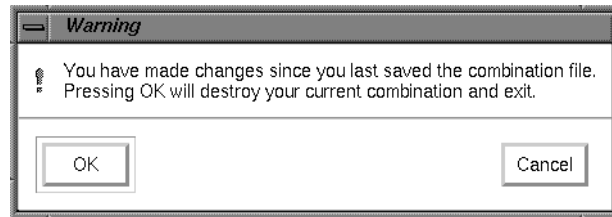
10. In the "Saving to hardware" dialog box that appears, click *Download* (see Figure D-8).



**Figure D-8** Saving to Hardware Dialog Box

The format combination is now loaded in the GE board's EEPROM, but it does not take effect until the graphics subsystem is restarted.

11. In the File pulldown menu in the main window, select "Exit."
12. Click *OK* when the Warning dialog box appears (see Figure D-9).



**Figure D-9** Exit Warning Dialog Box

13. Enter the following in the IRIX shell window to restart system graphics:

```
(/usr/gfx/stopgfx ; /usr/gfx/startgfx) &.
```

14. When the Login window appears, log in as root (superuser). The video system is now outputting a 960x680\_60 format on Channels 0 and 1.

The video system retains this configuration even after rebooting because the 960x680\_60 Video Format Combination is saved in the GE board's EEPROM.

To reset the EEPROM to the standard 1280 x 1024 format combination, enter `/usr/gfx/setmon -n 1280x1024_72` at the IRIX prompt. Then restart the graphics system (as in step 13) to activate the format combination reset. When the Login window appears, log in as root.

## Resizing a Single-Channel Combination

Before starting this exercise, be sure to read the information in “Reinitializing Graphics” on page 159.

In this final example, you create a single-channel combination that is “static resized” and is saved to and loaded from a combination file. Follow these steps:

1. Open an IRIX shell window, click the third mouse button and use the Size pulldown menu to change the shell to 80 x 24.
2. Place the 80 x 24 shell window behind the Video Format Combiner main window, but make sure the command-line prompt is visible.
3. Click *Ch0* on the Combiner’s main window. The Select Format window appears.
4. Find and double-click the *1280x1024\_72.vfo* file. The Channel 0 (Ch0) rectangle fills the entire 1280 x 1024 managed area in the main window.
5. In the Channel pulldown menu, select “Grab Window.” The cursor turns into a cross.
6. Move the cross (cursor) into the IRIX shell window and click the mouse button. The rectangle in the Combiner’s main window representing Ch0 now represents the area of the framebuffer covered by the 80 x 24 IRIX shell that you clicked in. See Figure D-10 for a screen example.

**Note:** This area becomes resized to fit the entire Channel 0 output when the combination is loaded. You can resize a channel’s input area by clicking and dragging any of the four corners of its main window rectangle. That resizing method is not covered in this exercise.

**Caution:** Do not move the IRIX shell window until you complete this exercise.

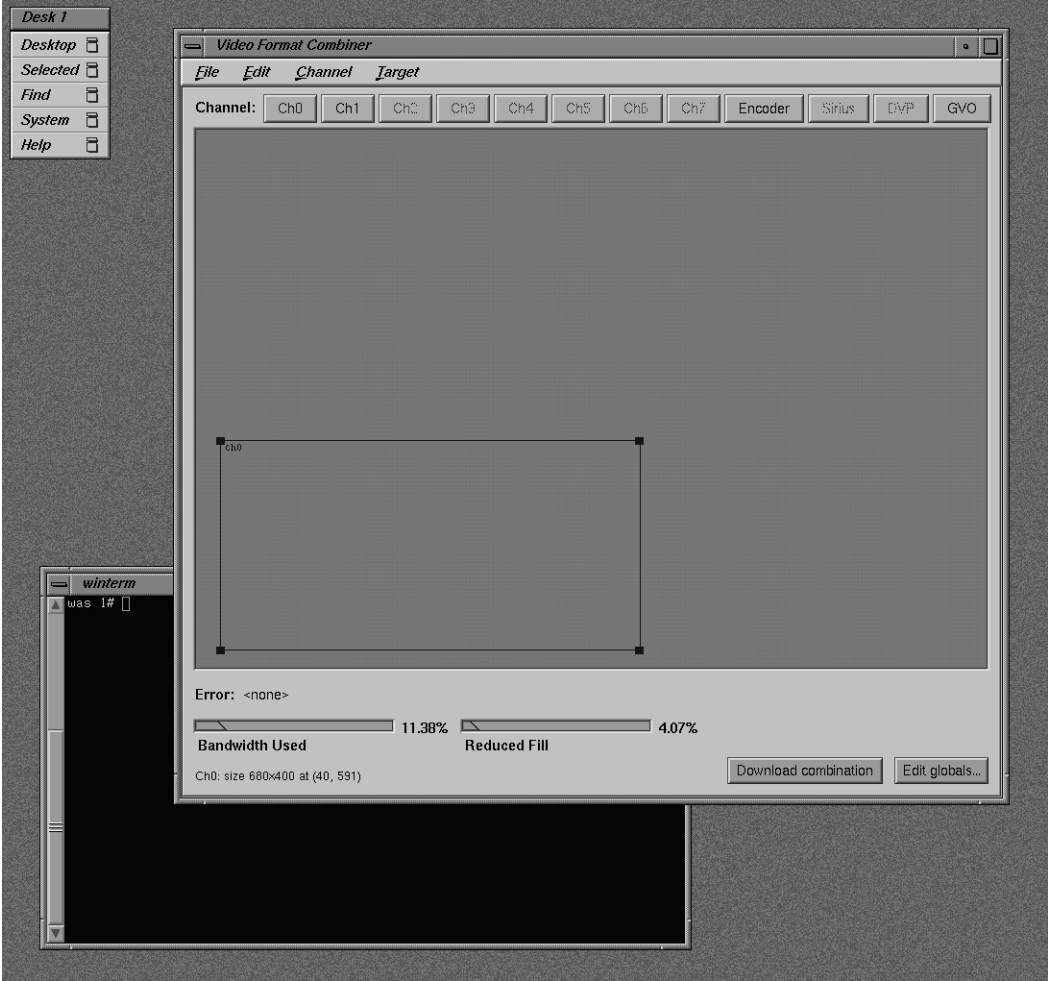
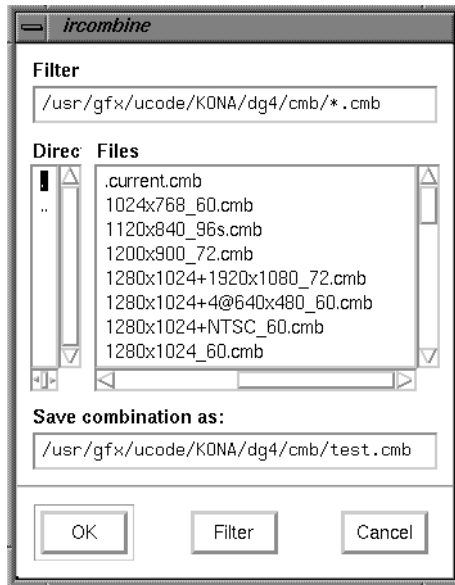


Figure D-10 Static Resize Selection

7. From the File pulldown menu in the Combiner main window, select "Save As." The *ircombine* window appears (see Figure D-11).



**Figure D-11** Save a Combination

8. In the "Save combination as" field, type `test.cmb` at the end of the path and click *OK*.
9. Select "Exit" from the File pulldown menu in the Combiner's main window.
10. In the shell window you clicked in step 6, enter

```
% /usr/gfx/setmon -n test
```

The screen blanks momentarily and then displays the IRIX shell window resized to 1280 x 1024 (the entire screen display).

**Note:** If no usable window appears, you can recover the default video display combination following the instructions in "Redisplaying Graphics" on page 177.

11. Revert to the previous display configuration by entering

```
% /usr/gfx/setmon -n 1280x1024_72.
```

The entire screen should reappear in the 1280 x 1024 format.

12. Select "Exit" from the File pulldown menu on the Combiner's main window to conclude the exercise.

## Using Ircombine With GVO

The Graphics to Video Option (GVO) provides direct graphics output to broadcast component digital video devices. If you have this option installed in your system, the GVO button on the main panel of ircombine will be enabled, and you will have an additional channel available under ircombine.

### Defining a Video Format Combination using GVO

To define a combination using GVO in genlocked mode, complete the following steps:

1. Click "CH0" in the combiner window. Select 1280x1024\_60.vfo from the files window. Click "OK". A large "Ch0" rectangle will appear in the combiner window.
2. Click "GVO" in the combiner window. A small "GVO" rectangle will appear in the upper-left corner of the combiner window.
3. Bring up the Attributes window by double-clicking the "GVO" button in the Combiner window, or by selecting "Edit Attributes" from the "Channel" menu. The GVO attributes window will appear (see Figure D-12). From this panel you can select a number of options for the GVO output channel. You should pay particular attention to the "Output Format", "Source Channel", "Pixel Format", "Data Format" and "Gamma" settings on this panel. When you have selected the values you want, click the "Close" button.

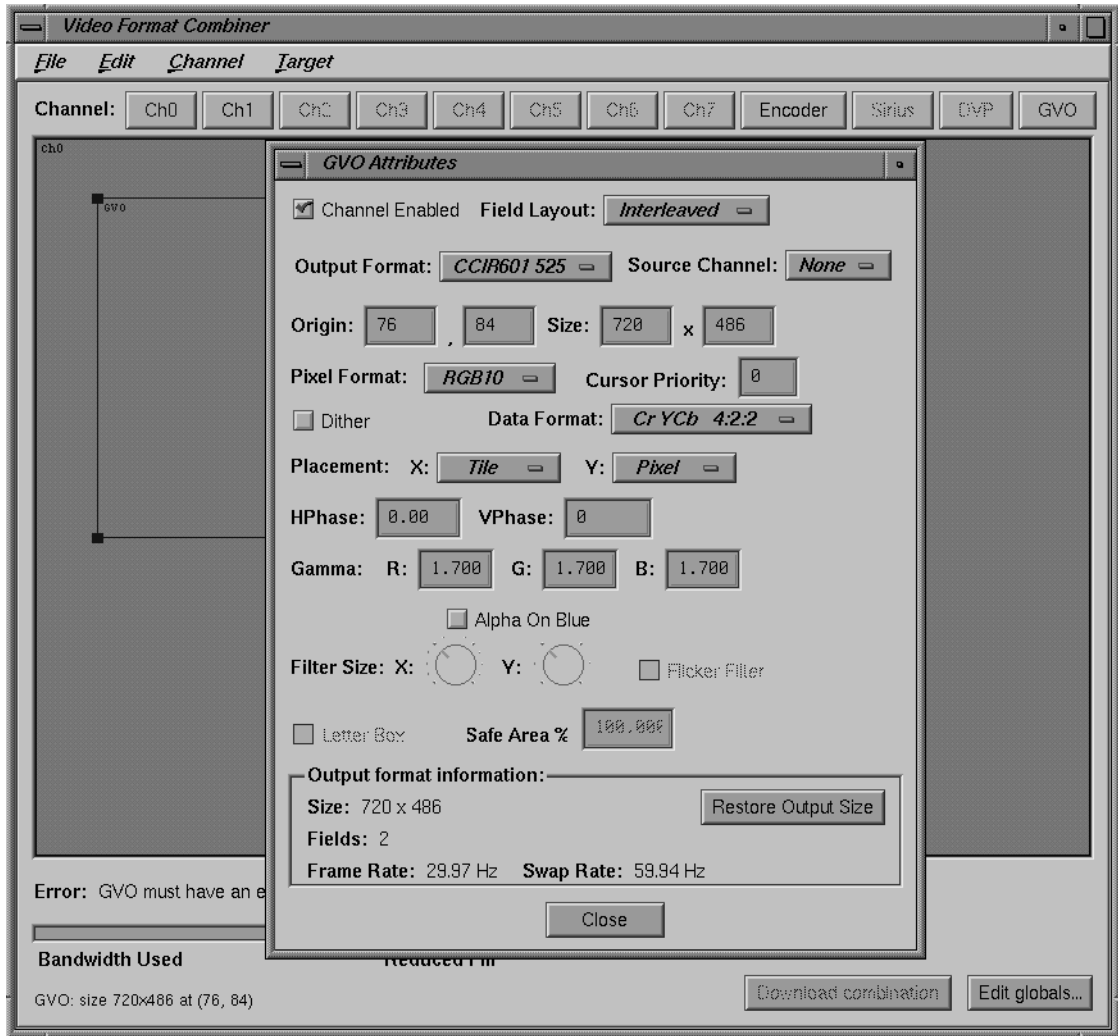


Figure D-12 GVO Attributes Window

4. GVO is normally used with the graphics subsystem genlocked to an external video source connected to the genlock input of the DG5 board. To enable this functionality, complete the following steps: :
  - Click the *Edit Globals* button on the main combiner window.
  - Click on the pop-up menu for “Sync Source” and select “External” as the value.
  - Click the *Browse* button next to the “Sync Format” text box.
  - Select “646x486\_30i.vfo” as the sync format and click OK.
5. You may now save or download this combination as usual. If you are working in an 50Hz environment, you would use “1280x1024\_50.vfo” on channel 0 and “768x576\_25i.vfo” as the external sync format.

## Redisplaying Graphics

If the monitor should stop displaying video during one of the examples or during any other type of Combiner use, the following steps should provide a solution:

1. Connect a monitor to Channel 0 that can display the required format(s). If video is still not visible, go on to step 2.
2. Log in to the system remotely or connect an ASCII terminal to serial port tty\_1, if possible. Become superuser (root) and enter the command

```
# /usr/gfx/setmon -n 72
```

If this does not work, enter

```
# /usr/gfx/setmon -x 72
```

Restart the graphics by entering

```
# (/usr/gfx/stopgfx ; /usr/gfx/startgfx) &.
```

3. Reboot the system using the System Controller if the first two steps do not work. If, after rebooting, the video still does not display, wait for several minutes and go to the next step for an additional process.
4. Enter 1; attempt to reboot the system to single user by entering

```
# /usr/gfx/setmon -x 72
```

(even though you are unable to see any screen display of your inputs). When you believe you have succeeded, reboot again.

Call your Onyx2 service provider for additional information and assistance if these steps do not restore your system's video output.

## Combiner Interface Summary

The Combiner interface has many functions besides those listed in the previous examples. You can use the Combiner to

- define a channel using an on-screen window as input
- copy an existing channel format and content to a new channel
- align one channel with another
- change the video format for a channel (or delete it entirely)
- edit the attributes (size, pixel format, and so on) of a channel
- select the "field layout" order in which data is scanned from the framebuffer
- select and copy a video format stored in a different file
- choose an output pixel format for a particular channel
- control cursor behavior in overlapping rectangles by setting the cursor priority
- allocate pixel width and depth for framebuffer fields
- set horizontal and vertical phase for a given channel
- specify whether sync components have sync enabled by default
- modify the brightness characteristics of the monitor
- change the default output video gain value for a channel
- save a combination of all the channels present in the Combiner's main window and make global changes to them
- arrange the pixels (set pixel depth) in the framebuffer to optimize framebuffer output speeds
- select the InfiniteReality internal sync (or use an external source that is connected to the "Genlock In" port)
- save a video format combination as a default and write it to EEPROM
- run a user-defined hardware configuration simulating more RM/TM boards than you have installed (used when an application is too large)



---

# Index

## Numbers

13W3 pinouts, 61  
21-inch monitor  
  connection of, 92  
24-inch monitor, 92  
68-pin SCSI connector, 84  
8-mm tape drive  
  front panel lights, 150  
  removing jammed cassettes, 151

## A

Action menu, 102  
adding a drive, 115  
ambient incoming air temperature, 128  
apropos command, xxi

## B

BALUN adapters, 82  
BaseIO assembly, 66

## C

cable bails, 115  
cable cover door, 109  
cable options, 63

cable pinout assignments  
  for the composite video (RCA) port, 75  
  for the Ethernet 10-BASE T port, 67

CD-ROM drive  
  front panel features, 154

cleaning, 150

cleaning cartridge  
  for jukebox tape drive, 150  
  useful life, 150

cleaning materials  
  8-mm tape drive, 150

clean the tape drive, instructions, 150

Combiner main window, 161

commands

  apropos, xxi  
  grelnotes, xxi  
  makewhatis, xxi  
  man, xxi  
  relnotes, xxi

components on the front of the graphics rack, 27

composite video (RCA), cable pinout  
  assignments, 75

compute module, 19

connectors, 25

controls, 25

Customer Replaceable Unit  
  defined, 107

**D**

- DAT drive
  - capacities, 148
  - data transfer rate, 148
  - front panel lights, 149
  - loading and unloading cassettes, 148
  - removing jammed cassettes, 148
- default video format, 92
- DG5 I/O panel, 61
- digital audio connectors, 82
- directory memory, 17
- disk module, 115
- distributed memory, 17
- documentation
  - available via the World Wide Web, xxii
  - release notes, xxi
- drives in the compute module, 112

**E**

- electrostatic discharge, 109
- ESD, 109

**F**

- Field Replaceable Unit
  - identifying, 112

**G**

- graphics BaseIO panel, 37
- graphics module, 19, 31
- graphics module midplane, 19
- graphics-to-video option, 61
- grelnotes command, xxi

**H**

- horizontal and vertical sync, 63

**I**

- Identifying Field Replaceable Units, 112
- incoming air temperature, 128
- independent memory source, 17
- indicators, 25
- InfiniteReality graphics pipes, 31
- insert a disk module, 115
- installation and removal procedures, 107
- interdependence of the XIO slots, 36
- IO6G, 37
- I/O panel, 37
- I/O subsystem, 14
- IRIX operating system, 104

**K**

- keyboard and mouse connectors, 72
- keyboard port, cable pinout assignments, 74
- KTOWN interface board, 48

**L**

- LEDs, 43
- LEDs on the module power supply, 136
- line level audio, 75
- line level inputs and outputs, 75
- loopthrough, 82

**M**

- main memory slots, 17
- major parts of the Onyx2, 25
- makewhatis command, xxi
- man command, xxi
- midplane, 19
- MMSC front panel display, 121
- module power supply problems, 135
- mouse cables, 72
- mouse extension cable, 72
- mouse port, cable pinout assignments, 74
- multidimensional mesh, 15
- multimodule System Controller, 121
- multimodule System Controller logic unit, 122
- multirack configuration, 51

**N**

- noncritical fan, 127

**O**

- Onyx2 multirack configurations, 51
- Onyx2 rack
  - physical characteristics, 22
- operating system, 104
- optional interface boards, 36

**P**

- page migration hardware, 17
- PDU power switch, 99
- physical characteristics
  - Onyx2 rack, 22

- physical inspection, 134
- physical location
  - requirements for chassis, 22
- pinouts for the monitor connectors, 61
- power distribution unit, 95
- Power Down option, 105
- Powering down the system, 109
- power off, 105
- power-on procedures, 95
- Power Up option, 102
- primary keyboard and mouse, 72
- processing board, 40
- processor activity screen, 103, 122

**R**

- R10000 microprocessors, 17
- reboot the system, 137
- release notes
  - how to view, xxi
- relnotes command, xxi
- remove a disk drive module, 113
- remove the module System Controller, 118
- required Node board slot positions, 40
- restore filesystems, 138
- RS-232 standard, 77

**S**

- safety information, 91
- scale the system bandwidth, 15
- SCSI-2 devices, 84
- second-level cache support, 17
- shared memory, 17
- soft power-off, 128

standard monitor, 92  
symmetric multiprocessing, 15  
System Controller serial console connectors, 125  
system crash, 143  
system power-on tests, 102  
system reset switch, 128  
system-wide reset, 127

**T**

tape drive, cleaning, 150  
Technical Publications Library, xxii

**U**

unload button, on tape drive, 150

**V**

vertical sync for monitors, 63

**W**

Weight, 145  
World Wide Web  
    documentation available via, xxii  
    Silicon Graphics URL (address), xxii

**X**

XIO boards, 19  
XIO rules, 36  
XIO slots, 33  
XLR connectors, 82



---

## Tell Us About This Manual

As a user of Silicon Graphics products, you can help us to better understand your needs and to improve the quality of our documentation.

Any information that you provide will be useful. Here is a list of suggested topics:

- General impression of the document
- Omission of material that you expected to find
- Technical errors
- Relevance of the material to the job you had to do
- Quality of the printing and binding

Please send the title and part number of the document with your comments. The part number for this document is 007-3457-003.

Thank you!

## Three Ways to Reach Us

- To send your comments by **electronic mail**, use either of these addresses:
  - On the Internet: [techpubs@sgi.com](mailto:techpubs@sgi.com)
  - For UUCP mail (through any backbone site): *[your\_site]!sgi!techpubs*
- To **fax** your comments (or annotated copies of manual pages), use this fax number: 415-965-0964
- To send your comments by **traditional mail**, use this address:

Technical Publications  
Silicon Graphics, Inc.  
2011 North Shoreline Boulevard, M/S 535  
Mountain View, California 94043-1389