

SGI® Altix™ 350
Quick Start Guide

007-4417-001

CONTRIBUTORS

Written by Dick Brownell

Illustrated by Dick Brownell, Dan Young and Chrystie Danzer

Production by Karen Jacobson

Additional contributions by Paul Pedersen., Lyle Stoll, Michael T Brown, Galen Flunker, Gary Meyer

COPYRIGHT

© 2004, Silicon Graphics, Inc. All rights reserved; provided portions may be copyright in third parties, as indicated elsewhere herein. No permission is granted to copy, distribute, or create derivative works from the contents of this electronic documentation in any manner, in whole or in part, without the prior written permission of Silicon Graphics, Inc.

LIMITED RIGHTS LEGEND

The electronic (software) version of this document was developed at private expense; if acquired under an agreement with the USA government or any contractor thereto, it is acquired as "commercial computer software" subject to the provisions of its applicable license agreement, as specified in (a) 48 CFR 12.212 of the FAR; or, if acquired for Department of Defense units, (b) 48 CFR 227-7202 of the DoD FAR Supplement; or sections succeeding thereto. Contractor/manufacture is Silicon Graphics, Inc., 1600 Amphitheatre Pkwy 2E, Mountain View, CA 94043-1351.

TRADEMARKS AND ATTRIBUTIONS

Silicon Graphics, SGI, the SGI logo, are registered trademarks and NUMAlink, and XIO are trademarks of Silicon Graphics, Inc., in the United States and/or other countries worldwide.

Record of Revision

Version	Description
001	January 2004 Original publication

Contents

Figures	vii
1. SGI Altix 350 Quick Start Guide	1
Positioning and Powering an Altix 350 System	2
Positioning an Altix 350 System.	2
Powering an Altix 350 System	3
NUMAlink™ Cabling for an Altix 350 System	5
Attaching a Serial Terminal to an Altix 350 System	7
Powering and Booting an Altix 350 System from a Serial Terminal	9
Powering and Booting From an L1 System Controller	9
Powering and Booting From an L2 System Controller	11
Troubleshooting an Altix 350 System	13

Figures

Figure 1-1	Connecting an Altix 350 Non-Racked System to Power	3
Figure 1-2	Connecting an Altix 350 Racked System to Power	4
Figure 1-3	Cabling in a Two-module Altix 350 System	5
Figure 1-4	Cabling in a Three-module Altix 350 System	6
Figure 1-5	Connecting a Serial Terminal to an L1 Controller	7
Figure 1-6	Connecting a Serial Terminal to an L2 Controller	8

SGI Altix 350 Quick Start Guide

This book guides a knowledgeable user through the installation, setup, and simple configuration of most SGI Altix 350 systems.

For more detailed information, or for setup instructions for more complex Altix 350 systems, please refer to the *SGI Altix 350 User's Guide*.

Positioning and Powering an Altix 350 System

Depending on the system ordered, your Altix 350 system may have been shipped as a number of individual chassis or mounted in a rack. This section describes positioning and powering your system in either of these instances.

Positioning an Altix 350 System

If your Altix 350 system was shipped as a number of individual chassis, they may be placed on a flat surface, as shown in Figure 1-1 on page 3, or placed in a rack. For instructions on mounting Altix 350 chassis in a rack, and for information about rack positioning, refer to the *SGI Altix 350 User's Guide*.

Powering an Altix 350 System

Plug your Altix 350 system into a suitable power outlet, as shown in Figure 1-1 (for non-racked chassis) or Figure 1-2 (for racked chassis). Refer to the *Altix 350 User's Guide* for detailed power requirements.

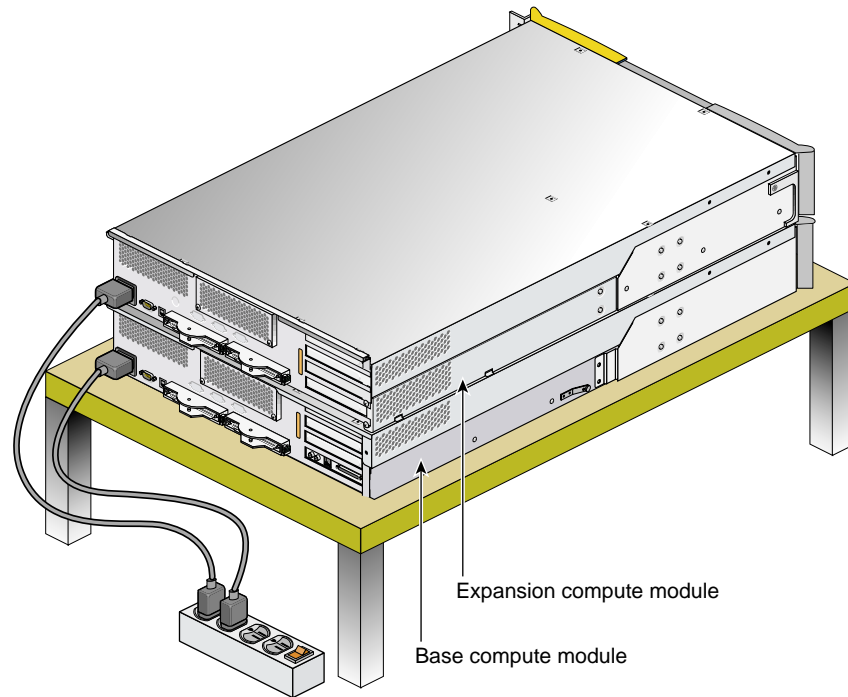

Figure 1-1 Connecting an Altix 350 Non-Racked System to Power

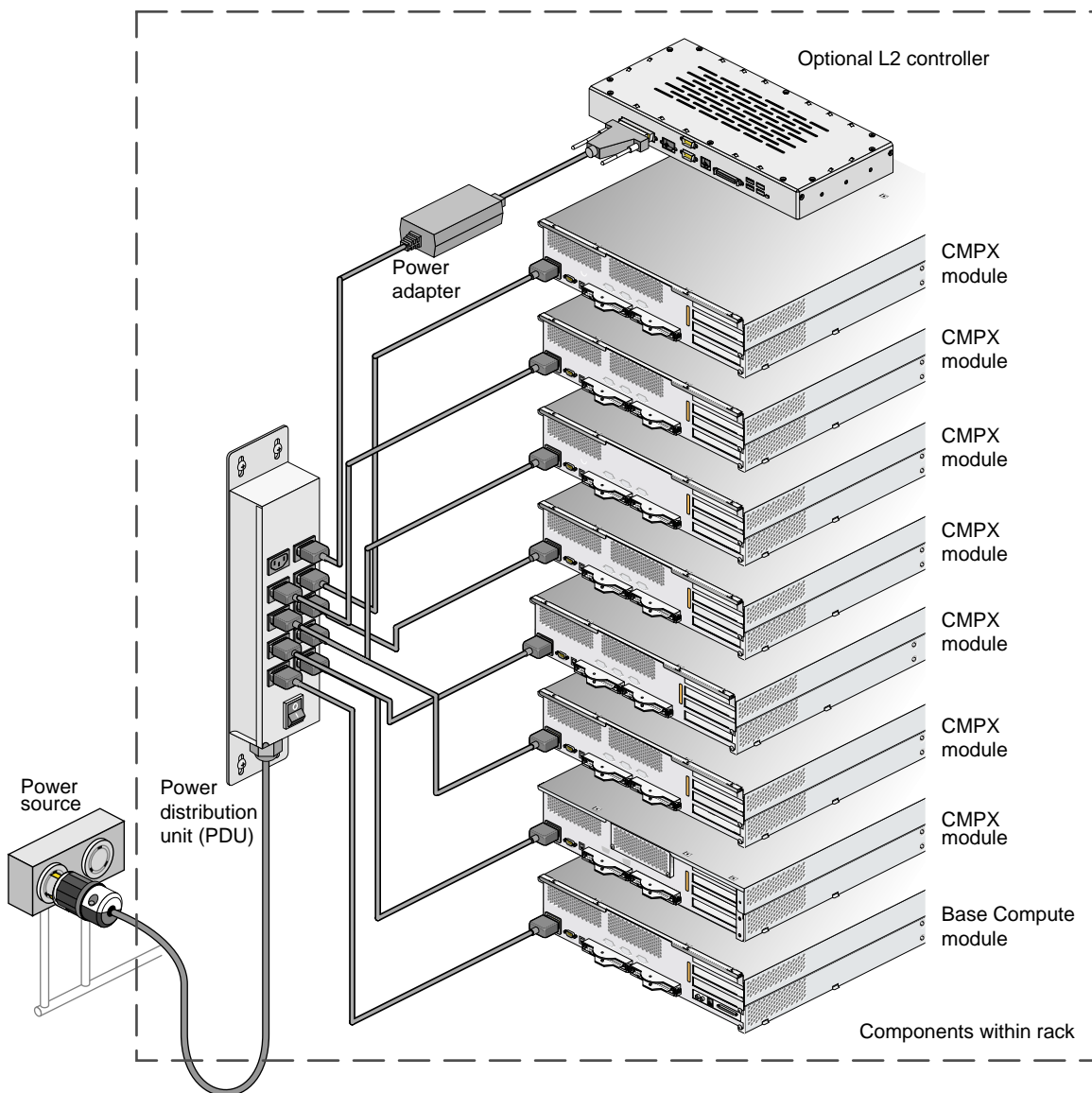

Figure 1-2 Connecting an Altix 350 Racked System to Power

NUMAlink™ Cabling for an Altix 350 System

If your system was shipped from SGI® with the modules already mounted in a rack and the NUMAlink cables preinstalled, you should proceed to “Attaching a Serial Terminal to an Altix 350 System” on page 7.

This section describes the NUMAlink cabling for some simple configurations. For instructions to cable more complex systems, see the *SGI Altix 350 User’s Guide*.

Figure 1-3 shows a system with a base compute module and a CMPX module.

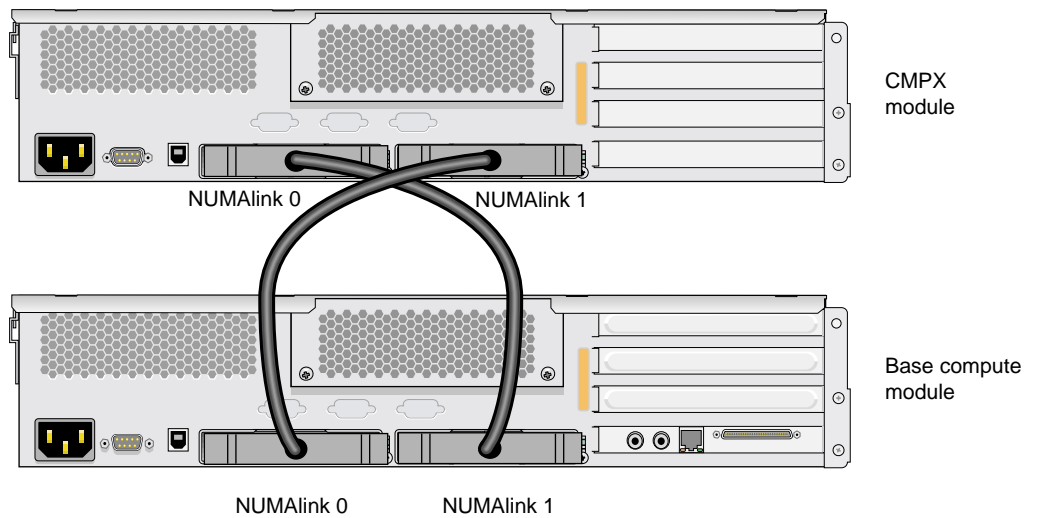

Figure 1-3 Cabling in a Two-module Altix 350 System

Figure 1-4 shows a system with a base compute module, one CMPX module, and one CPU expansion module.

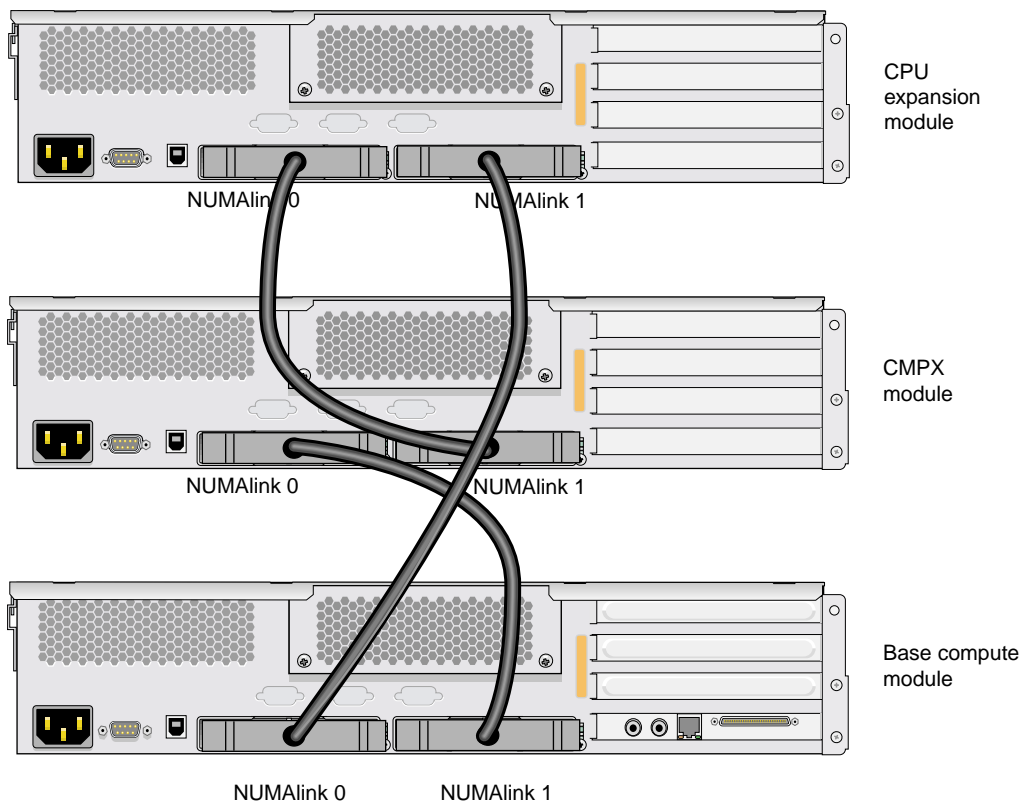

Figure 1-4 Cabling in a Three-module Altix 350 System

Attaching a Serial Terminal to an Altix 350 System

If your Altix 350 system was shipped in a rack without an optional Level 2 controller, or was shipped as individual chassis, you should connect a serial terminal to the Level 1 controller contained in the host system master CPU module as shown in Figure 1-5.

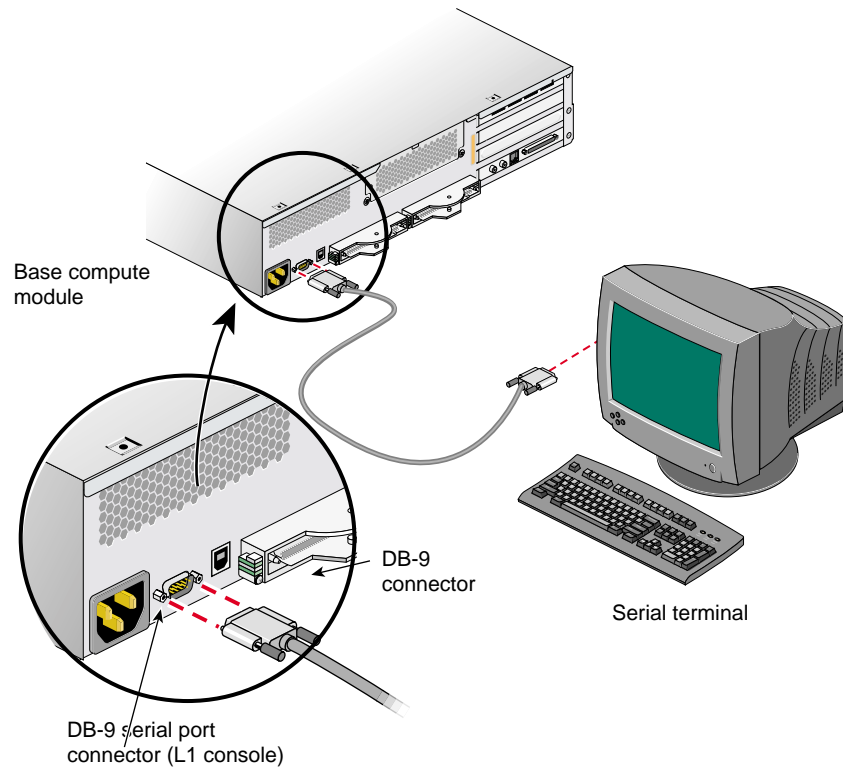

Figure 1-5 Connecting a Serial Terminal to an L1 Controller

If your Altix 350 system was shipped in a rack with an optional Level 2 controller, you should connect a serial terminal to that Level 2 controller, which is located in the top of the rack as shown in Figure 1-6 (this view shows the back of the rack).

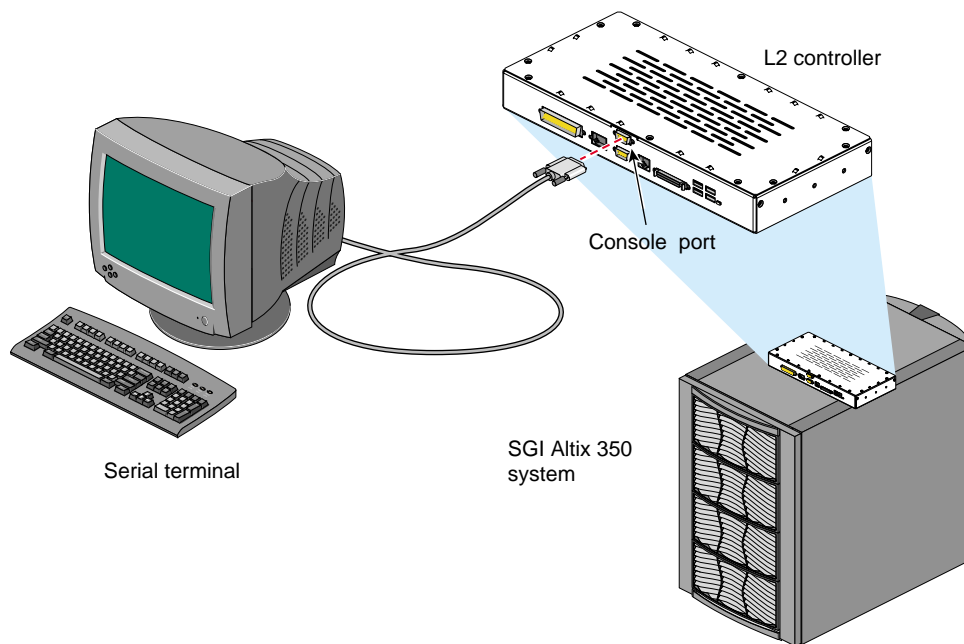

Figure 1-6 Connecting a Serial Terminal to an L2 Controller

Powering and Booting an Altix 350 System from a Serial Terminal

The power up procedure varies, depending on whether your serial terminal is connected directly to an L1 system controller or the optional L2 system controller. Refer to the appropriate section below.

Powering and Booting From an L1 System Controller

Use the following steps to connect your Altix 350 system via serial cable to the L1 controller (see Figure 1-5):

1. Attach a serial cable to the lowest compute node in the system using the following:
 - Serial DB9 Female to Female cable P/N 018-0691-001
 - The settings for the L1 serial port are as follows:
 - Baud rate 38400
 - 8 data bits
 - 1 stop bit
 - No parity
 - RTS/CTS flow control (hardware flow control)
2. Attach the other end of the cable to a PC serial port with “cu” or other similar terminal emulation program.
3. On the PC enter the following command.

```
cu -l ttyS0 -s 38400
```

This assumes the tty device on the PC is ttyS0.
There should be a “connected” response.
Hit return again and you should get a L1 prompt:

```
001c01-L1>
```

4. From the L1 prompt enter the command “cfg”
This should return a list of all the modules in the system.

```
001-L2>cfg
L2 137.38.68.26: - 001 (LOCAL)
L1 137.38.68.26:0:0 - 001c01
L1 137.38.68.26:0:1 - 001c03
L1 137.38.68.26:0:5 - 001c05
001c04-L1>
```
5. If all the modules in your system are not seen, check the NUMAlink cabling, also insure that the L1 is powered on all modules.
6. To power up the system, enter the L1 command “pwr u”

```
001c01-L1>pwr u
001c01-L1>
```
7. When the L1 prompt returns, enter a “cntrl d” to break in to the console.
This will show the output of the power on boot process.
This will get you to a EFI SHELL prompt.

Powering and Booting From an L2 System Controller

Use the following steps to connect your Altix 350 system via serial cable to an optional L2 controller (see Figure 1-6):

1. Attach a serial cable to the lowest compute node in the system using the following:
 - Serial DB9 Female to Female cable P/N 018-0691-001
 - The settings for the L2 serial port are as follows:
 - Baud rate 38400
 - 8 data bits
 - 1 stop bit
 - No parity
 - RTS/CTS flow control (hardware flow control)
2. Attach the other end of the cable to a PC serial port with “cu” or other similar terminal emulation program.
3. On the PC enter the following command.

```
cu -l ttyS0 -s 38400
```

This assumes the tty device on the PC is ttyS0.

There should be a “connected” response.

Hit return again and you should get a L2 prompt:

```
001-L2>
```

1. From the L2 prompt enter the command “cfg”
This should return a list of all the modules in the system.

```
001-L2>cfg
```

```
:0 - 001c01
```

```
:1 - 001c03
```

```
:5 - 001c05
```

```
001-L2>
```

2. If all the modules in your system are not seen, check the NUMAlink cabling, also insure that the L1 is powered on all modules.

3. To power up the system, enter the L2 command “pwr u”
001-L2>**pwr u**
001-L2>
4. When the L2 prompt returns, enter a “cntrl d” to break in to the console.
This will show the output of the power on boot process.
This will get you to a EFI SHELL prompt.

Connecting the L2 Controller to a Local Ethernet Network

The L2 controller can be configured with a static IP address or the L2 controller will obtain an IP address from a DHCP server on the network.

Use the following steps to configure your optional L2 controller with a static IP address:

Step 1 can be omitted if the L2 controller will use DHCP.

1. From the L2 prompt, enter the command “ip”
001-L2>**ip aaa.bb.cc.ddd 255.255.255.0 aaa.bb.cc.255**
The first sting is the system IP address. Contact your network administrator for your system IP address. The second string is netmask, and the third string is the broadcast address. The first three sections of the broadcast address are the same as the system IP address.
2. Assign the system name using the command “sysname”
001-L2>**sysname** (*your system name*)
3. To prevent L2s from different systems from communicating with each other, enable the multi system option “msys”
001-L2>**msys on**
4. Finally, reboot the L2 controller.
001-L2>**reboot_l2**

Troubleshooting an Altix 350 System

If you are experiencing problems with your Altix 350 system, you can follow the steps detailed in the *SGI Altix 350 User's Guide* to help isolate and correct the problem.

If the problems are with your host system you should refer to the user's manual for that host system.

For problems not addressed in the above locations, please contact your SGI authorized support representative.

