



SGI® UV™ 20 System User Guide

007-5900-001

COPYRIGHT

© 2013 Silicon Graphics International Corp. All rights reserved; provided portions may be copyright in third parties, as indicated elsewhere herein. No permission is granted to copy, distribute, or create derivative works from the contents of this electronic documentation in any manner, in whole or in part, without the prior written permission of SGI.

LIMITED RIGHTS LEGEND

The software described in this document is “commercial computer software” provided with restricted rights (except as to included open/free source) as specified in the FAR 52.227-19 and/or the DFAR 227.7202, or successive sections. Use beyond license provisions is a violation of worldwide intellectual property laws, treaties and conventions. This document is provided with limited rights as defined in 52.227-14.

The electronic (software) version of this document was developed at private expense; if acquired under an agreement with the USA government or any contractor thereto, it is acquired as “commercial computer software” subject to the provisions of its applicable license agreement, as specified in (a) 48 CFR 12.212 of the FAR; or, if acquired for Department of Defense units, (b) 48 CFR 227-7202 of the DoD FAR Supplement; or sections succeeding thereto. Contractor/manufacturer is SGI, 46600 Landing Parkway, Fremont, CA 94538.

TRADEMARKS AND ATTRIBUTIONS

Silicon Graphics, SGI, and the SGI logo, and SGI UV are trademarks or registered trademarks of Silicon Graphics International Corp. in the United States and/or other countries worldwide.

InfiniBand is a registered trademark of the InfiniBand Trade Association. Intel and Xeon are trademarks or registered trademarks of Intel Corporation or its subsidiaries in the United States and other countries. Linux is a registered trademark of Linus Torvalds, used with permission by SGI. MegaRAID and LSI Logic are trademarks or registered trademarks of LSI Logic Corporation. PCIe and PCI-X are registered trademarks of PCI SIG.

All other trademarks mentioned herein are the property of their respective owners.

Record of Revision

Version	Description
001	February 2013 Original printing.

Contents

	Record of Revision	iii
	About This Guide	xi
1	System Overview	1
	System Features and Configuration Options	2
	Server Components	4
	Hard Disk Drive (HDD) Bays and Front Panel	4
	Control Panel	5
	Back Panel	6
	I/O Devices	8
	Hard Disk Drives	9
	Slimline Optical Drives	9
	Solid-State Drives (SSDs)	10
2	System Safety	11
	Electrical Safety Precautions	11
	General Safety Precautions	13
	ESD Precautions	14
3	System Operation and Monitoring	15
	Front Panel Controls and LEDs	16
	Hard Disk Drive (HDD) LEDs	18
	Power Supply LED	20
4	Chassis Maintenance	21
	Before You Start	22
	Tools and Supplies Needed	22
	Left-Right and User Position	22
	Removing and Installing the Front Fan Bezel	23

	Removing the Front Fan Bezel 23
	Installing the Front Fan Bezel 24
	Removing the Rack Handles 25
	Installing the Rack Handles 26
	Removing the System Top Cover 27
	Replacing the System Cover 29
	Replacing the Power Supply Modules 30
	Removing the Power Supply Modules 30
	Installing the Power Supply Modules 31
	Installing Hot-Swap Hard Drives 32
	Replacing a Fan Module 35
	Replacing a Front Fan 36
	Replacing a Middle Fan 37
	Mounting the Chassis to a Rack 39
	Removing the Chassis from a Rack 42
A	Power and Environmental Specifications 45
	Power Rating 45
	Wattage Limitation of the PCI Loading 46
	Environmental Specifications 46
B	Regulatory Compliance Information 49
C	Rail Kit Installation. 51
D	BMC Error Codes 55

Figures

Figure 1-1	SGI UV 20 Server	1
Figure 1-2	Overhead View of Server with the Top Cover Removed	4
Figure 1-3	Hard Disk Drive Bays	4
Figure 1-4	Front Control Panel	5
Figure 1-5	Back Panel	6
Figure 1-6	Front Panel I/O Connections	8
Figure 1-7	Back Panel I/O Connections	8
Figure 2-1	Installing the Onboard Battery	12
Figure 3-1	Front Control Panel	15
Figure 3-2	Control Panel Components	16
Figure 3-3	HDD Carrier LEDs	18
Figure 4-1	Removing the Front Fan Bezel	23
Figure 4-2	Installing the Front Fan Bezel	24
Figure 4-3	Removing a Rack Handle	25
Figure 4-4	Installing a Rack Handle	26
Figure 4-5	Removing the System Top Cover	28
Figure 4-6	Installing the System Cover	29
Figure 4-7	Removing a Power Supply Module	30
Figure 4-8	Installing a Power Supply Module	31
Figure 4-9	Removing HDD Carrier	32
Figure 4-10	Removing Drive Blank	33
Figure 4-11	Inserting Drive into Carrier	33
Figure 4-12	Inserting HDD Carrier into Chassis	34
Figure 4-13	System Fans	35
Figure 4-14	Replacing a Front Fan	36
Figure 4-15	Removing a Middle Fan	37
Figure 4-16	Inserting a Middle Fan	38
Figure 4-17	Removing Inner Member from Slides	39

Figure 4-18	Attaching Slides to the Rack 40
Figure 4-19	Installing the Inner Members to the Chassis 41
Figure 4-20	Installing the Chassis in the Rack. 41
Figure 4-21	Extending Slides to Remove the Chassis 42
Figure 4-22	Removing the Inner Member from the Chassis 43
Figure C-1	Attaching Rail Slides to Rack. 51
Figure C-2	Extending Rail Slides 52
Figure C-3	Attaching Chassis to Rail Slides 53
Figure C-4	Rail Slide Release Tab 54

Tables

Table 1-1	Features and Configuration Options	2
Table 1-2	Control Panel Buttons and LEDs.	5
Table 1-3	Back Panel Components	7
Table 1-4	I/O Connections	9
Table 3-1	Control Panel Components and Functions	16
Table 3-2	HDD Status LED Functions	19
Table 3-3	HDD Activity LED Functions	19
Table 3-4	Power Supply LED States	20
Table A-1	Power Rating of the Power Supply	45
Table A-2	Wattage Limitation of the PCIe Loading	46
Table A-3	Environmental Specifications	46
Table B-1	Product Regulatory Compliance	49
Table D-1	BMC Beep Codes	55

About This Guide

This guide provides an overview of the features and the major components of the SGI® UV™ 20 server. It also provides system monitoring and maintenance information as well as important safety and regulatory specifications.

Audience

This guide is written for owners, installers, system administrators, and users of the UV 20 server. It is written with the assumption that the reader has a good working knowledge of computers and computer systems.

Chapter Descriptions

The following topics are covered in this guide:

- Chapter 1, “System Overview”
Provides an overview of the server features and components.
- Chapter 2, “System Safety”
Provides system safety information.
- Chapter 3, “System Operation and Monitoring”
Describes control buttons and LEDs on the control panel as well as LEDs on the disk drive carriers.
- Chapter 4, “Chassis Maintenance”
Describes procedures for replacing system components.

- **Appendix A, “Power and Environmental Specifications,”**
Lists input/output voltage specifications for the power supplies and also environmental specifications for operating the system.
- **Appendix B, “Regulatory Compliance Information,”**
Summarizes the product regulatory information.
- **Appendix C, “Rail Kit Installation,”**
Describes the steps to install the rail kit.
- **Appendix D, “BMC Error Codes,”**
Describes the BMC beep codes associated with failure conditions.

Related Publications

The following SGI and LSI documents are relevant to the UV 20 server:

- *MegaRAID® SAS Software User's Guide*, publication number 860-0488-xxx
- *SGI Foundation Software Start Here*, publication number 007-5641-xxx
- *SGI Performance Suite Start Here*, publication number 007-5680-xxx
- *SGI InfiniteStorage* series documentation
- Man pages (online)

You can obtain SGI documentation (as well as the pertinent LSI books), release notes, or man pages in the following ways:

- Refer to the SGI Technical Publications Library at <http://docs.sgi.com>. Various formats are available. This library contains the most recent and most comprehensive set of online books, release notes, man pages, and other information.
- You can also view man pages by typing `man <title>` on a command line.

Conventions

The following conventions are used throughout this document:

Convention	Meaning
Command	This fixed-space font denotes literal items such as commands, files, routines, path names, signals, messages, and programming language structures.
<i>variable</i>	The italic typeface denotes variable entries and words or concepts being defined. Italic typeface is also used for book titles.
user input	This bold fixed-space font denotes literal items that the user enters in interactive sessions. Output is shown in nonbold, fixed-space font.
[]	Brackets enclose optional portions of a command or directive line.
...	Ellipses indicate that a preceding element can be repeated.
man page(x)	Man page section identifiers appear in parentheses after man page names.
GUI element	This font denotes the names of graphical user interface (GUI) elements such as windows, screens, dialog boxes, menus, toolbars, icons, buttons, boxes, fields, and lists.

Product Support

SGI provides a comprehensive product support and maintenance program for its products. SGI also offers services to implement and integrate Linux applications in your environment.

- Refer to <http://www.sgi.com/support/>
- If you are in North America, contact the Technical Assistance Center at +1 800 800 4SGI or contact your authorized service provider.
- If you are outside North America, contact the SGI subsidiary or authorized distributor in your country.

Reader Comments

If you have comments about the technical accuracy, content, or organization of this document, contact SGI. Be sure to include the title and document number of the manual with your comments. (Online, the document number is located in the front matter of the manual. In printed manuals, the document number is located at the bottom of each page.)

You can contact SGI in any of the following ways:

- Send e-mail to the following address: techpubs@sgi.com
- Contact your customer service representative and ask that an incident be filed in the SGI incident tracking system.
- Send mail to the following address:

SGI
Technical Publications
46600 Landing Parkway
Fremont, CA 94538

SGI values your comments and will respond to them promptly.

System Overview

The SGI UV 20 server is a 2U rackmount server (see [Figure 1-1](#)). It has two main subsystems: the 2U server chassis and a quad-processor serverboard.

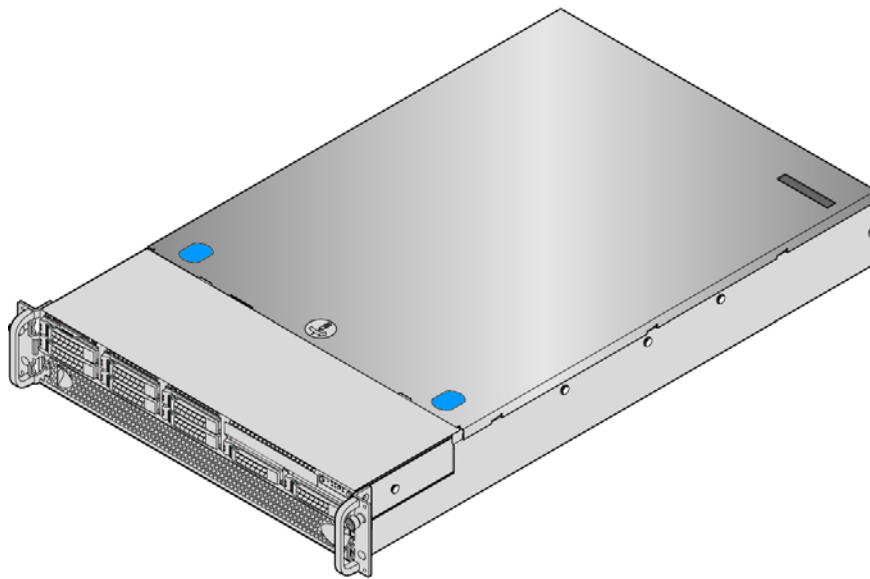

AF006121

Figure 1-1 SGI UV 20 Server

This chapter describes the main features and configuration options of the server as well as the components pertinent to monitoring and maintaining your server.

System Features and Configuration Options

Table 1-1 summarizes the features and configuration options of the SGI UV 20 server.

Table 1-1 Features and Configuration Options

Feature	Description
Dimensions	<ul style="list-style-type: none"> – Height: 3.43 inches (87.3 mm) – Width: 17.24 inches (438.0 mm) – Depth: 28.0 inches (712 mm) – Weight: approximately 75 pounds (38 kg)
Processor Support	Supports up to four Intel® Xeon® processors E5-4600 product family with a Thermal Design Power (TDP) of up to 130 W.
Memory	<ul style="list-style-type: none"> – 48 DIMM slots – 3 DIMMs per channel – 4 Memory channels per processor – Registered DDR3 DIMMs – Memory DDR3 data transfer rates of 800, 1066, 1333 MT/s and 1600 MT/s – DDR3 standard I/O voltage of 1.5V (all speed) and DDR3 low voltage of 1.35V
Chipset	Intel C600-A chipset
External I/O Connections	<ul style="list-style-type: none"> – Video (back panel) – RJ-45 Serial-A port – 2 RJ-45 network interface connectors supporting 100/1000/10000Mb – USB 2.0 connectors (4 on back panel)
Internal I/O Connectors/Headers	<ul style="list-style-type: none"> – One Type-A USB 2.0 connector – One internal USB header – One DH-10 Serial-B port connector
Available I/O Module Options	<p>The following I/O modules utilize a single proprietary on-board connector. An installed I/O module can be supported in addition to standard on-board features and any add-in expansion cards.</p> <ul style="list-style-type: none"> – Quad-Port 1 GbE module based on Intel I350 Ethernet controller – Dual-Port 10GBase-T module based on Intel I350 Ethernet controller – Dual-SFP+ port 10GbE module based on Intel 82500 10GbE controller – Single-Port FDR-speed InfiniBand module with QSFP connector
System Fans	<ul style="list-style-type: none"> – 11 dual-rotor-managed system fans – 1 internal power supply fan for each installed power supply unit

Table 1-1 Features and Configuration Options **(continued)**

Feature	Description
Riser Cards	Support for two riser card slots. Each riser card slot supports three PCIe Gen 3 x16 slots.
Video	<ul style="list-style-type: none"> – Integrated 2D video controller – 16 MB DDR3 memory
On-board Storage Controllers and Options	<ul style="list-style-type: none"> – One low-profile eUSB 2x5 pin connector to support low-profile eUSB solid state devices – Two single-port SATA connectors capable of supporting up to 6 GB/sec – Two 4-port mini-SAS connectors supporting up to 3 GB/s SAS/SATA
Server Management	Integrated Baseboard Management Controller (IPMI 2.0 compliant)
Power Supply Options	Two power supplies with the following options: <ul style="list-style-type: none"> – 1600W (1+1), redundant, hot-swap capable – 1600W (1+0 or 2+ 0), not redundant
Storage Bay Options	8 x 2.5" SATA/SAS hot-swap HDD bays
Solid-State Drive (SSD) Support	Up to two 2.5" internal SSDs are supported.
Rack Mount Kit Options	Basic slide rail kit, bundled with system package

Server Components

This section describes the server components pertinent to monitoring and maintaining your server. There are also quick reference labels inside of the chassis cover to assist you in identifying components. [Figure 1-2](#) provides an overhead view of the server with the top cover removed.

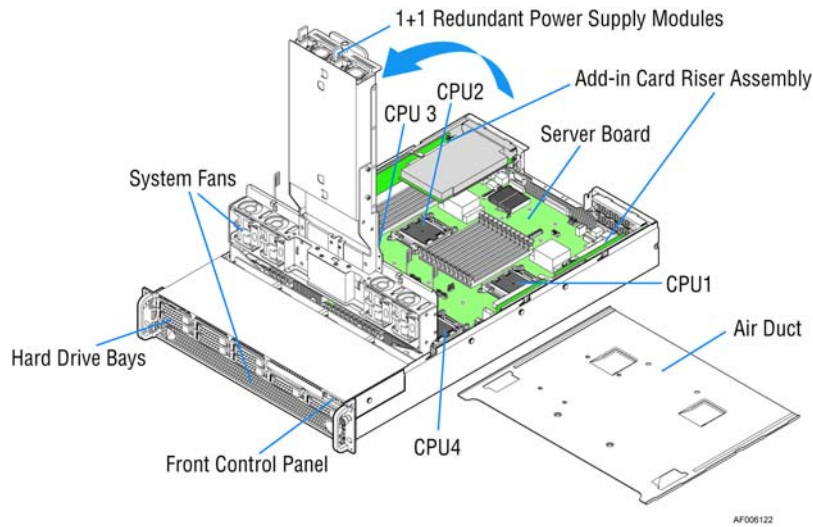

Figure 1-2 Overhead View of Server with the Top Cover Removed

Hard Disk Drive (HDD) Bays and Front Panel

The UV 20 server supports the 8 x 2.5" configuration of hard disk drives. [Figure 1-3](#) shows the 8-bay configuration.

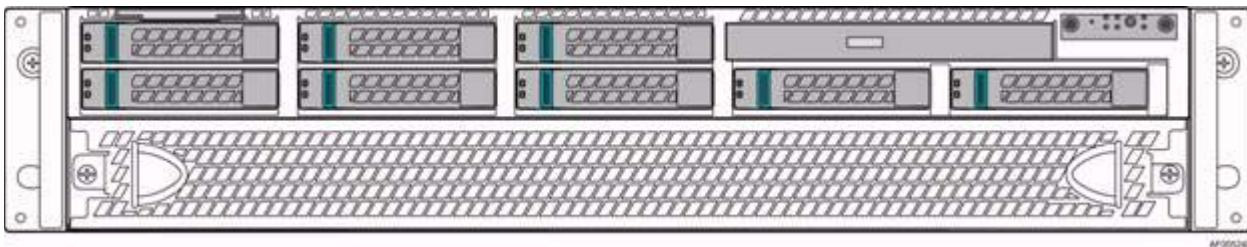

Figure 1-3 Hard Disk Drive Bays

Control Panel

As shown in [Figure 1-3](#), the control panel is in the top right portion of the front panel. [Figure 1-4](#) shows the control buttons and LEDs on the control panel.

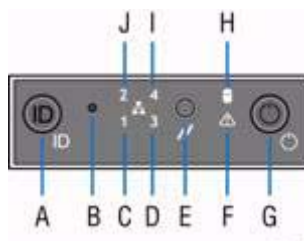

Figure 1-4 Front Control Panel

[Table 1-2](#) identifies the components. For a description of the function of these buttons and LEDs, see [Chapter 3, “System Operation and Monitoring.”](#)

Table 1-2 Control Panel Buttons and LEDs

Label	Description	Label	Description
A	System ID Button with integrated LED	F	System Status LED
B	NMI Button (recessed, tool required for use)	G	Power Button with integrated LED
C	NIC-1 Activity LED	H	Hard Drive Activity LED
D	Not used	I	Not used
E	System Cold Reset Button	J	NIC-2 Activity LED

Back Panel

Figure 1-5 shows the components on the back panel of the server.

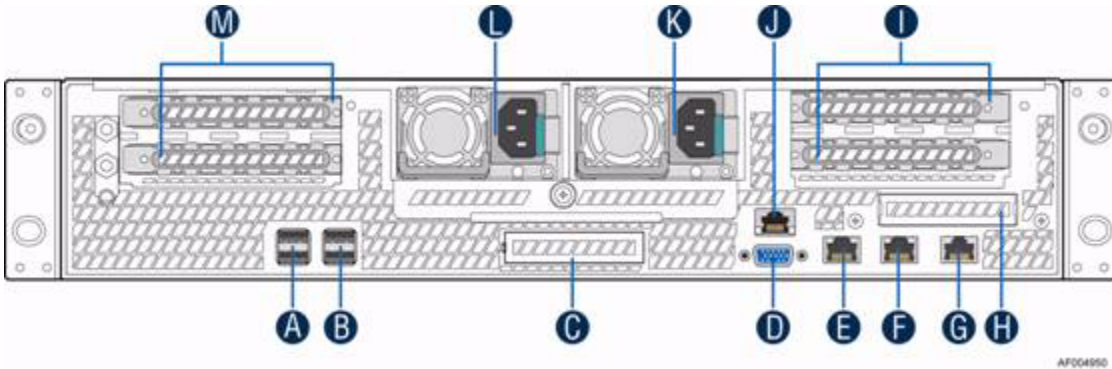

Figure 1-5 Back Panel

Table 1-3 identifies the components shown in Figure 1-5.

Table 1-3 Back Panel Components

Label	Description	Label	Description
A	USB ports	H	I/O module ports/connectors (optional)
B	USB ports	I	Add-in adapter slots from riser card
C	I/O module ports/connectors (optional)	J	RMM4 NIC port (optional)
D	Video connector	K	Power supply module #2
E	NIC-1	L	Power supply module #1
F	NIC-2	M	Add-in adapter slots from riser card
G	RJ-45 Serial-A port		

I/O Devices

The UV 20 server supports a variety of I/O devices such as hard drives, DVD drives, and SSDs. The connections for I/O devices are located on the front or back panel of the server, as shown in Figure 1-6 and Figure 1-7.

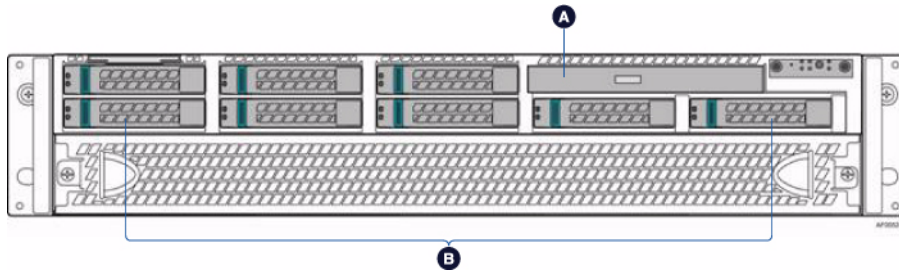

Figure 1-6 Front Panel I/O Connections

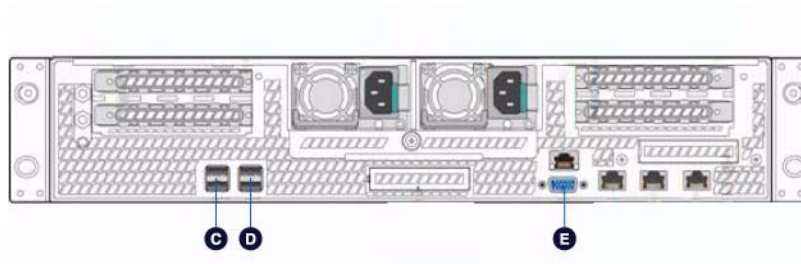

Figure 1-7 Back Panel I/O Connections

Table 1-4 identifies the various I/O connections shown in Figure 1-6 and Figure 1-7.

Table 1-4 I/O Connections

Label	Description
A	Slimline optical drive bay
B	Hard disk drive bays
C	USB ports
D	USB ports
E	Video port

Hard Disk Drives

The UV 20 server supports a maximum of 8 x 2.5” hard drives. For instructions on installing hard drives, “[Installing Hot-Swap Hard Drives](#)” on page 32.

Notes:

- SAS drives are only supported when proper Intel RAID C600 Upgrade Key or Intel Integrated RAID Module is installed.
- Drives can consume up to 17 watts of power each. Drives must be specified to run at a maximum ambient temperature of 45°C.

Slimline Optical Drives

The slimline optical drive carrier can be used with a single slimline optical drive. One slimline carrier is included with your server system. The optical drive must be purchased separately.

The drive in the optical drive carrier is NOT hot-swappable. The system power must be turned off to insert or remove the slimline optical drive carrier.

Solid-State Drives (SSDs)

The SSDs are mounted under a shelf behind the power supplies. The following items describe the UV 20 SSD support:

- Up to two internal 2.5" SSDs are supported.
- Two types of SSDs are supported:
 - 160 GB, 3 GB/s SATA, MLC flash memory
 - 300 GB, 3 GB/s SATA, MLC flash memory
- Each SSD requires one of the single-port, 6GB/s SATA ports. So does a DVD. If you have a DVD configured, the server then supports only one SSD.
- The SSDs are not hot-swappable.

System Safety

This chapter describes basic safety precautions.

Electrical Safety Precautions

Basic electrical safety precautions should be followed to protect yourself from harm and the SGI UV 20 system from damage, as follows:

- Be aware of the locations of the power on/off switch on the chassis as well as the room's emergency power-off switch, disconnection switch or electrical outlet. If an electrical accident occurs, you can then quickly remove power from the system.
- Do not work alone when working with high voltage components.
- Power should always be disconnected from the system when removing or installing main system components, such as the serverboard, memory modules and disk drives. When disconnecting power, you should first power down the operating system first and then unplug the power cords. The unit has more than one power supply cord. Disconnect two power supply cords before servicing to avoid electrical shock.
- When working around exposed electrical circuits, another person who is familiar with the power-off controls should be nearby to switch off the power if necessary.
- Use only one hand when working with powered-on electrical equipment. This is to avoid making a complete circuit, which will cause electrical shock. Use extreme caution when using metal tools, which can easily damage any electrical components or circuit boards they come into contact with.
- Do not use mats designed to decrease static electrical discharge as protection from electrical shock. Instead, use rubber mats that have been specifically designed as electrical insulators.
- The power supply power cords must include a grounding plug and must be plugged into grounded electrical outlets.

- Serverboard Battery



Caution: There is a danger of explosion if the onboard battery is installed upside down, which will reverse its polarities (see [Figure 2-1](#)). This battery must be replaced only with the same or an equivalent type recommended by the manufacturer. Dispose of used batteries according to the manufacturer's instructions.

- Mainboard replaceable soldered-in fuses: Self-resetting PTC (Positive Temperature Coefficient) fuses on the mainboard must be replaced by trained service technicians only. The new fuse must be the same or equivalent as the one replaced. Contact technical support for details and support.

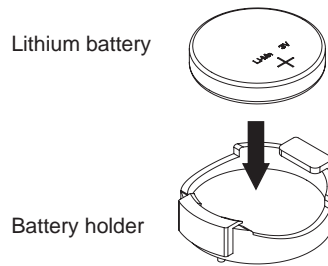

Figure 2-1 Installing the Onboard Battery

General Safety Precautions

Follow these rules to ensure general safety:

- Keep the area around the SGI UV 20 system clean and free of clutter.
- The SGI UV 20 system might approach 75 lbs (38 kg) when fully loaded. When lifting the system, two people at either end should lift slowly with their feet spread out to distribute the weight. Always keep your back straight and lift with your legs.
- Place the chassis top cover and any system components that have been removed away from the system or on a table so that they won't accidentally be stepped on.
- While working on the system, do not wear loose clothing such as neckties and unbuttoned shirt sleeves, which can come into contact with electrical circuits or be pulled into a cooling fan.
- Remove any jewelry or metal objects from your body, which are excellent metal conductors that can create short circuits and harm you if they come into contact with printed circuit boards or areas where power is present.
- After accessing the inside of the system, close the system back up and secure it to the rack unit with the retention screws after ensuring that all connections have been made.

ESD Precautions



Caution: Electrostatic discharge (ESD) is generated by two objects with different electrical charges coming into contact with each other. An electrical discharge is created to neutralize this difference, which can damage electronic components and printed circuit boards.

The following measures are generally sufficient to neutralize this difference before contact is made to protect your equipment from ESD:

- Use a grounded wrist strap designed to prevent static discharge.
- Keep all components and printed circuit boards (PCBs) in their antistatic bags until ready for use.
- Touch a grounded metal object before removing the board from the antistatic bag.
- Do not let components or PCBs come into contact with your clothing, which may retain a charge even if you are wearing a wrist strap.
- Handle a board by its edges only; do not touch its components, peripheral chips, memory modules or contacts.
- When handling chips or modules, avoid touching their pins.
- Put the serverboard and peripherals back into their antistatic bags when not in use.
- For grounding purposes, make sure your computer chassis provides excellent conductivity between the power supply, the case, the mounting fasteners and the serverboard.

System Operation and Monitoring

Figure 3-1 shows the control panel at the top right of the front panel. There are several LEDs on the control panel as well as others on the hard drive carriers and power supplies. The LEDs keep you constantly informed of the overall status of the system as well as the activity and health of specific components. There are also control buttons on the control panel. This chapter describes the buttons and LEDs.

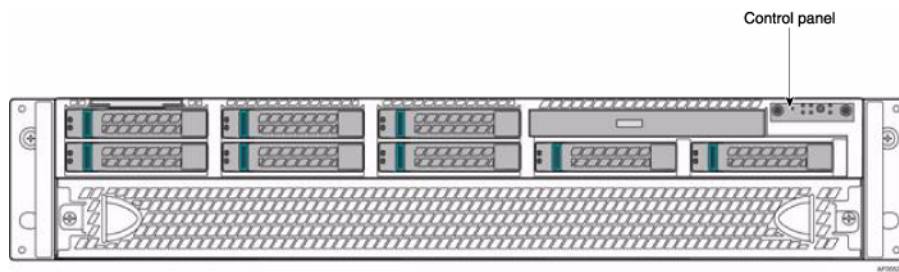

Figure 3-1 Front Control Panel

Front Panel Controls and LEDs

The control panel contains control buttons and status LEDs. [Figure 3-2](#) shows the components of a control panel.

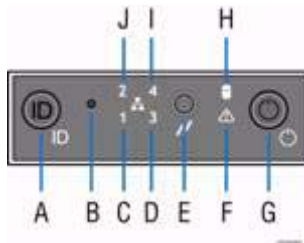

Figure 3-2 Control Panel Components

[Table 3-1](#) describes the control panel components and their functions.

Table 3-1 Control Panel Components and Functions

Label	Button/LED	Color	Condition	Function
A	System ID Button with LED	Blue	On	Highlights targeted system. Can be activated by the button or software.
B	NMI Button			Used for diagnostics.
C,J	Network Link/Activity LEDs	Green	On	No access to LAN link.
			Blink	LAN activity.
			Off	No link.
D				Not used.
E	System Cold Reset Button			When pressed, this button reboots and re-initializes the system.

Table 3-1 Control Panel Components and Functions **(continued)**

Label	Button/LED	Color	Condition	Function
F	System Status LED	Green	On	System ready/No alarm.
			Blink	System ready, but degraded: – Redundancy lost such as the power supply or fan failure. – Non-critical temp/voltage threshold. – Battery failure. – Predictive power supply failure.
		Amber	On	Critical Alarm: critical power modules failure, critical fans failure, voltage (power supply), critical temperature and voltage
			Blink	Non-Critical Alarm: Redundant fan failure, redundant power module failure, non-critical temperature and voltage
			Off	– Power off: System unplugged. – Power on: System powered off and in standby, no prior degraded\non-critical\critical state.
G	System Power Button with LED	Green	On	Power On/ACPI S0 state
			Blink	Sleep/ACPI S1 state
			Off	Power Off/ACPI S5 state
H	Hard Drive Activity LED			When lit, indicates drive activity from the on-board HDD controllers.
I				Not used.

Notes:

- Blink rate is ~1 Hz at 50% duty cycle.
- It is also off when the system is powered off (S5) or in a sleep state (S1).
- The power LED sleep indication is maintained on standby by the chipset. If the system is powered down without going through the BIOS, the LED state in effect at the time of power off is restored when the system is powered on until the BIOS clear it.
- If the system is not powered down normally, it is possible the Power LED will blink at the same time the system status LED is off due to a failure or configuration change that prevents the BIOS from running.

Hard Disk Drive (HDD) LEDs

Figure 3-3 shows the location of the LEDs for HDD carriers.

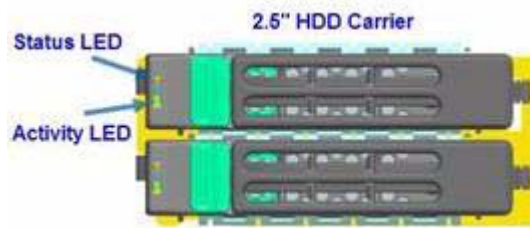

Figure 3-3 HDD Carrier LEDs

Table 3-2 describes the functions of the Status LED.

Table 3-2 HDD Status LED Functions

LED Color	LED Behavior	Drive Status
Amber	Off	No access and no fault.
	Solid On	Hard drive fault has occurred.
	Blink	– RAID rebuild in progress (1Hz). – Identify (2Hz).

Table 3-3 describes the functions of the Activity LED.

Table 3-3 HDD Activity LED Functions

LED Color	Drive Condition	Drive Type	LED Behavior
Green	Power on with no drive activity.	SAS	LED stays on.
		SATA	LED stays off.
	Power on with drive activity.	SAS	LED blinks off when processing a command.
		SATA	LED blinks off when processing a command.
	Power on and drive spun down.	SAS	LED stays off.
		SATA	LED stays off.
	Power on and drive spinning up.	SAS	LED blinks.
		SATA	LED stays off.

Power Supply LED

There is a single bi-color LED (green/amber) to indicate the power supply status. [Table 3-4](#) describes the different states of the LED.

Table 3-4 Power Supply LED States

LED State	Power Supply (PS) State
Off	No AC power to any PS.
Green	Output on and Ok.
Green, 1Hz blink	AC present (only 12VSB on). PS off or PS in cold redundant state.
Green, 2Hz blink	PS firmware updating.
Amber	<ul style="list-style-type: none">– PS critical event causing a shutdown/failure (OCP, OVP, fan failure)– AC cord unplugged or AC power lost. A second power supply in parallel still has AC input power.
Amber, 1Hz blink	PS warning events where the power supply continues to operate (high temperature, high power, high current, slow fan).

Chassis Maintenance

For warranty and safety considerations, SGI designates the following chassis components as customer-replaceable units (CRUs):

- Power supplies
- Fans
- Disk drives

These components are all hot-swappable; that is, you can replace them without powering down the server. A trained service technician should install and replace all other components.

This chapter describes the following chassis maintenance activities:

- “Removing and Installing the Front Fan Bezel” on page 23
- “Removing the Rack Handles” on page 25
- “Installing the Rack Handles” on page 26
- “Removing the System Top Cover” on page 27
- “Replacing the System Cover” on page 29
- “Replacing the Power Supply Modules” on page 30
- “Installing Hot-Swap Hard Drives” on page 32
- “Replacing a Fan Module” on page 35
- “Mounting the Chassis to a Rack” on page 39
- “Removing the Chassis from a Rack” on page 42

Before You Start



Warning: Review the warnings and precautions listed in this manual before setting up or servicing this chassis. These include the items described in **Chapter 2, “System Safety.”**

Tools and Supplies Needed

- Phillips (cross head) screwdriver (#1 bit and #2 bit)
- Needle-nosed pliers
- Anti-static wrist strap and conductive foam pad (recommended)

Left-Right and User Position

All references to left, right, front, top, and bottom assume you are facing the front of the chassis as it would be positioned for normal operation.

Removing and Installing the Front Fan Bezel

As shown in [Figure 4-1](#), 7 of the 11 system fans are located at the front of the chassis and are covered by a bezel.

Removing the Front Fan Bezel

Follow these steps to remove the front fan bezel:

1. Loosen the two screws on left and right ends.
See **A** in [Figure 4-1](#).
2. Remove the front fan bezel from the chassis.
See **B** in [Figure 4-1](#).

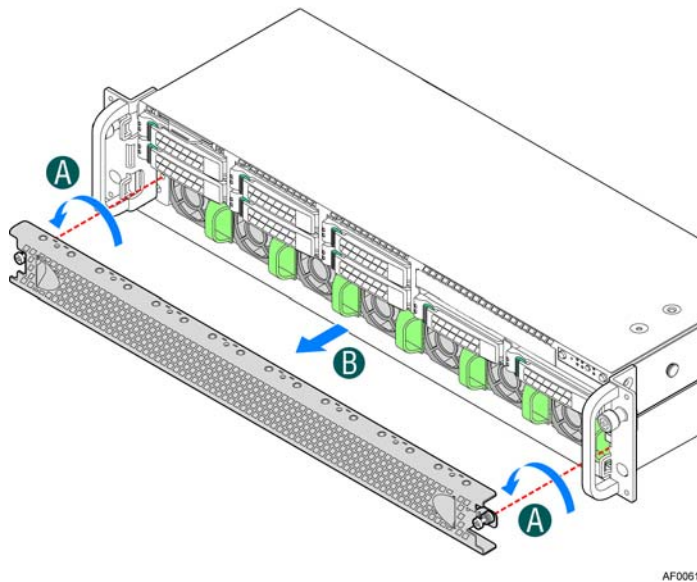

Figure 4-1 Removing the Front Fan Bezel

Installing the Front Fan Bezel

Follow these steps to install the front fan bezel:

1. Slide in the bezel.
See **A** in Figure 4-2.
2. Secure the bezel to the chassis with the two screws on left and right ends.
See **B** in Figure 4-2.

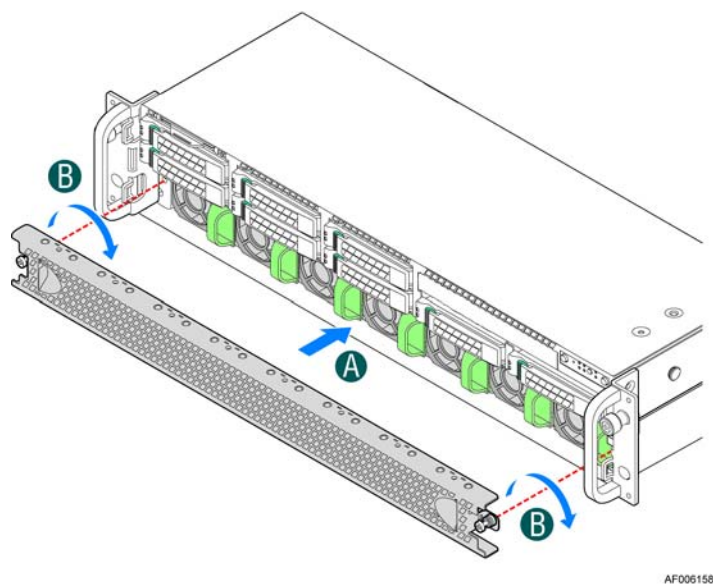

Figure 4-2 Installing the Front Fan Bezel

Removing the Rack Handles

To remove a rack handle, do the following:

1. Remove the two screws holding the rack handle in place.

See Figure 4-3.

2. Remove the rack handle from the chassis.

See Figure 4-3.

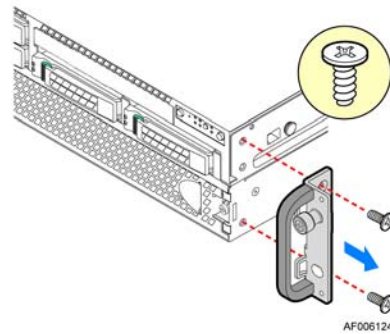

Figure 4-3 Removing a Rack Handle

Installing the Rack Handles

To install a rack handle, do the following:

1. Align the rack handle with the two holes on the side of the chassis.
See [Figure 4-4](#).
2. Attach the rack handle to the chassis with two screws.
See [Figure 4-4](#).

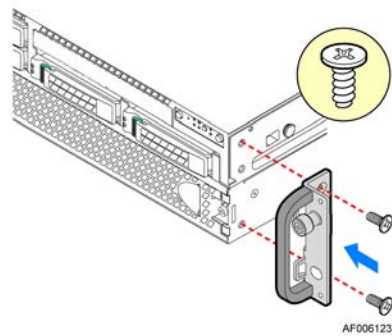

Figure 4-4 Installing a Rack Handle

Removing the System Top Cover

The server system must be operated with the system cover in place to ensure proper cooling. You will need to remove the top cover to add or replace components inside of the server. Before removing the top cover, power down the server and unplug all peripheral devices and the power cable(s).

Note: A non-skid surface or a stop behind the server system may be needed to prevent the server system from sliding on your work surface.

To remove the system cover, use the following steps:

1. Observe the safety and ESD precautions in [Chapter 2, “System Safety.”](#)
2. Turn off all peripheral devices connected to the server.
3. Turn off the server.
4. Disconnect the power cord.

5. Remove the screws.
See **A** in Figure 4-5.
6. Depress the latches.
See **B** in Figure 4-5.
7. Slide the cover back and lift upward.

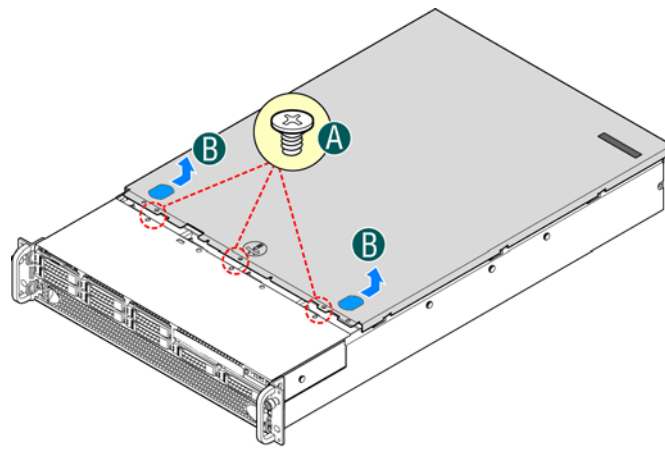

AF006125

Figure 4-5 Removing the System Top Cover

Replacing the System Cover

To replace the system cover, use the following steps:

1. Place the system cover onto the chassis and slide the cover forward to engage the recessed edge at the front of the cover.

See **A** in Figure 4-6.

2. Tighten the screw at the front.

See **B** in Figure 4-6.

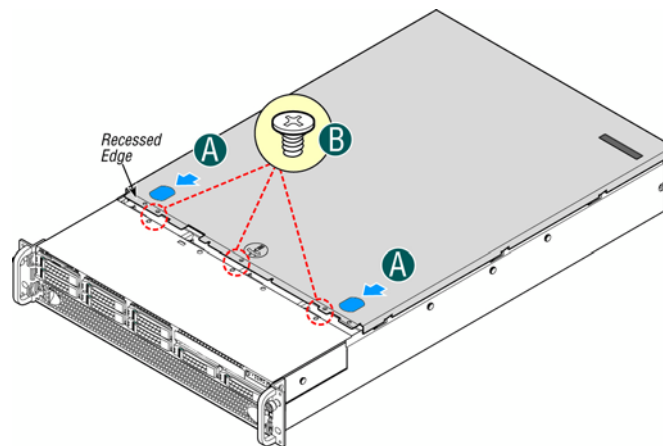

AF006126

Figure 4-6 Installing the System Cover

Replacing the Power Supply Modules

The system is equipped with two power supply modules for redundancy. They are hot-swappable.

Note: A server configured with multiple GPGPU cards may not be configured with redundant power supplies. In this case, the power supplies are not hot-swappable.

Removing the Power Supply Modules

To remove the power supply modules, use the following steps:

1. As shown in [Figure 4-7](#), push the green latch in the direction shown while pulling the module out of the chassis by the handle.
2. Repeat step 1 to remove the second power supply module.

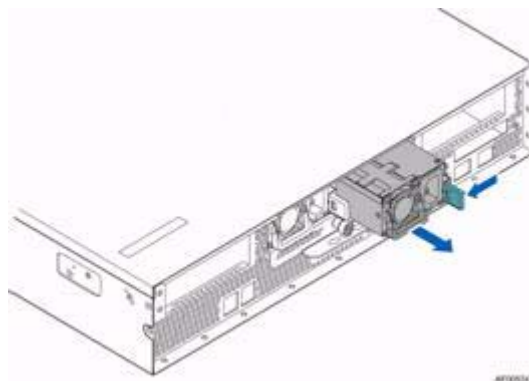

Figure 4-7 Removing a Power Supply Module

Installing the Power Supply Modules

To install the power supply modules, use the following steps:

1. Align and slide the module into the power supply cage as shown in [Figure 4-8](#).
2. Push the module along the rail until the latch locks in position with a click.
3. Repeat steps 1 and 2 to install the second module.

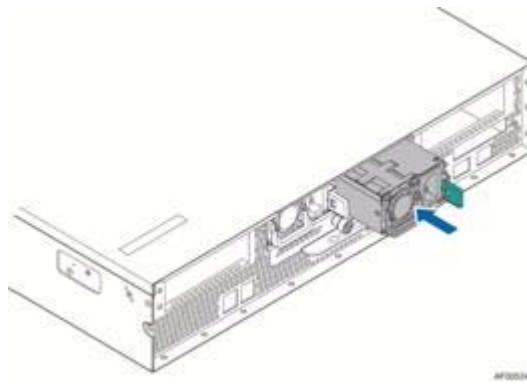

Figure 4-8 Installing a Power Supply Module

Installing Hot-Swap Hard Drives

Caution: To maintain proper system cooling, use drive carriers with plastic drive blanks to populate drive bays that would be otherwise empty.

To install a HDD into the chassis, use the following steps.

1. Remove the drive carrier by pressing the green latch to unlock it.
See **A** in Figure 4-9.
2. Pull out the black lever and slide the carrier out.
See **B** in Figure 4-9.

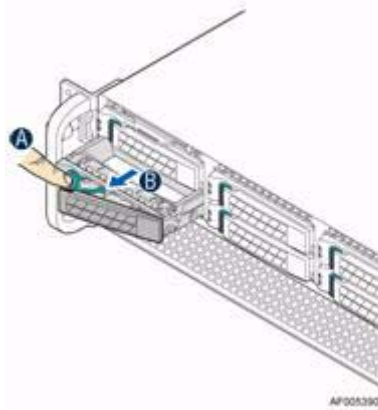

Figure 4-9 Removing HDD Carrier

3. Remove the four screws securing the plastic drive blank from the HDD carrier.
See **C** in Figure 4-10.
4. Remove the plastic drive blank from the HDD carrier.
See **D** in Figure 4-10.

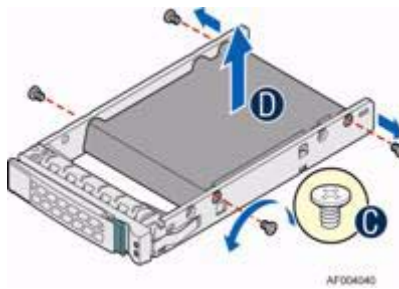

Figure 4-10 Removing Drive Blank

5. Install the hard disk drive using the four screws and ensure the connector end of the drive matches the backplane connector.
See **E** in Figure 4-11.

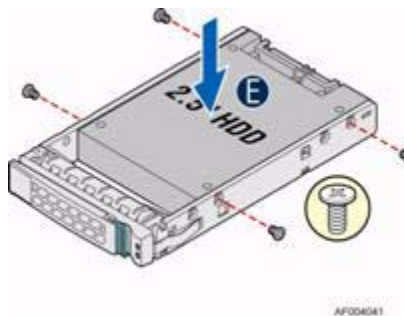

Figure 4-11 Inserting Drive into Carrier

6. With the lever open, insert the hard disk drive assembly into the chassis and push in the lever to lock it into place.

See **F** in Figure 4-12.

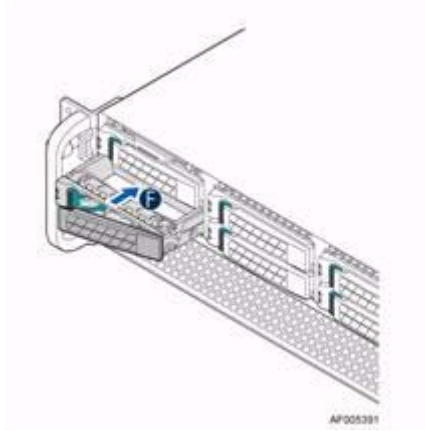
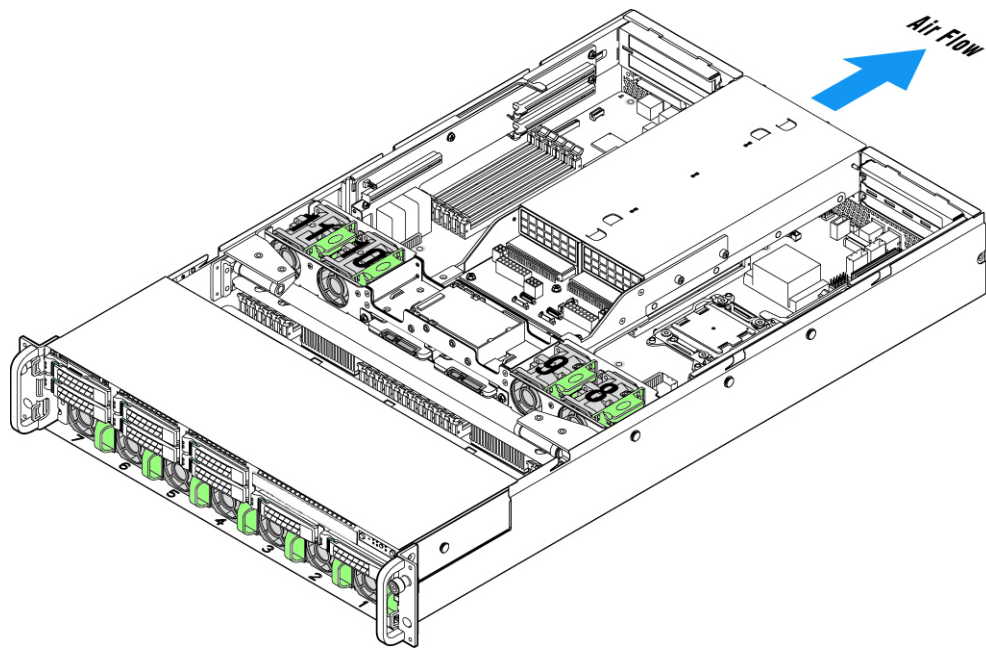

Figure 4-12 Inserting HDD Carrier into Chassis

Replacing a Fan Module

As shown in [Figure 4-13](#), seven of the system fans are located at the front of the chassis (front fans). The other four fans are in the middle of the chassis (middle fans).



AF006156

Figure 4-13 System Fans

Replacing a Front Fan

To replace a front fan, do the following:

1. Remove the front fan bezel.

See section “Removing and Installing the Front Fan Bezel” on page 23.

2. Pull the system fan straight out to remove it from the fan slot.

See Figure 4-14.

3. Replace the system fan by guiding it into the slot and firmly pressing in to ensure that it is properly seated.

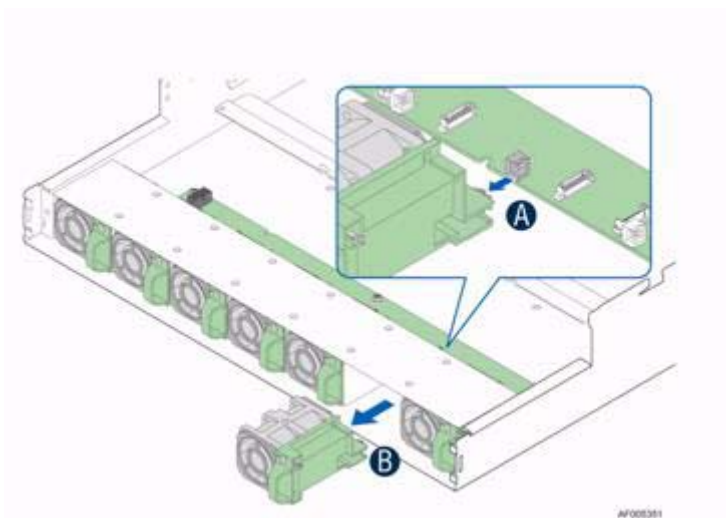
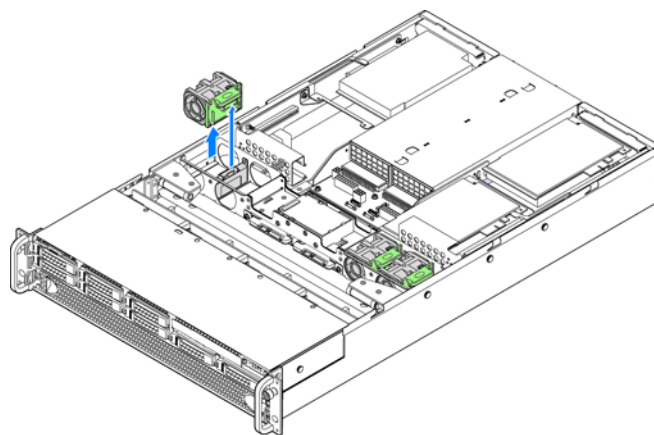

Figure 4-14 Replacing a Front Fan

Replacing a Middle Fan

To replace a middle fan, do the following:

1. Remove the system cover.
See section “Removing the System Top Cover” on page 27.
2. Pull the system fan straight up to remove it from the fan slot.
See Figure 4-15.



AF006132

Figure 4-15 Removing a Middle Fan

3. Replace the system fan by guiding it into the slot and firmly pressing down to ensure that it is properly seated.

See [Figure 4-16](#).

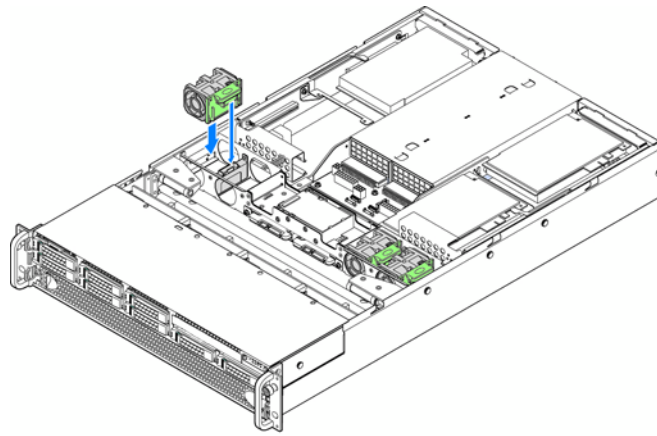

AF006131

Figure 4-16 Inserting a Middle Fan

Mounting the Chassis to a Rack

A slide rail kit is bundled with the server and is packed in the same shipping box with the chassis. Use the following steps to install the chassis in the rack.

1. Remove the inner member from the slides as shown in [Figure 4-17](#).

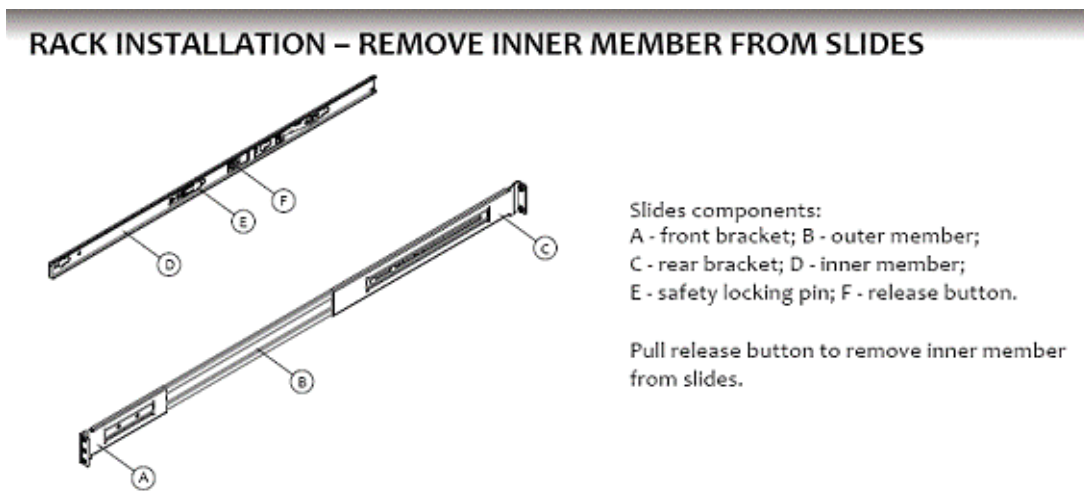
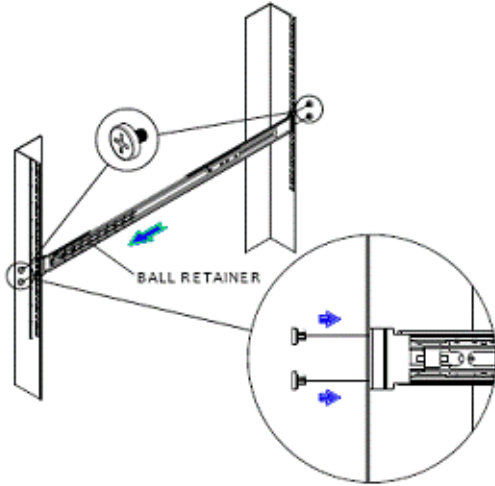

Figure 4-17 Removing Inner Member from Slides

2. Attach the slides to the rack as shown in Figure 4-18.

RACK INSTALLATION – INSTALL SLIDES TO RACK



Align brackets to desired vertical position on rack and insert fasteners.
Move ball retainer to the front of slides.

Figure 4-18 Attaching Slides to the Rack

3. Install the inner members to the chassis as shown in [Figure 4-19](#).

CHASSIS INSTALLATION – INSTALL INNER MEMBER TO CHASSIS

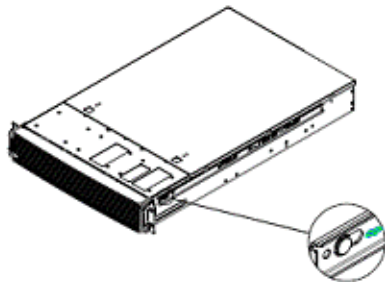

Align inner member key holes to standoffs on chassis, move inner member following the direction in left pictures.

Figure 4-19 Installing the Inner Members to the Chassis

4. Install the chassis to the fixed slides as shown in [Figure 4-20](#).

CHASSIS INSTALLATION – INSTALL CHASSIS TO FIXED SLIDES

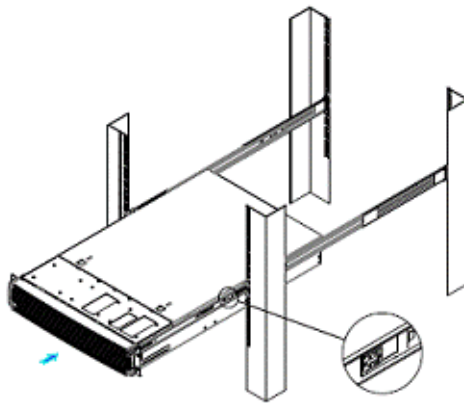

Pull the release button in the inner member to release the lock and allow the chassis to close.

Figure 4-20 Installing the Chassis in the Rack

Removing the Chassis from a Rack

To remove the chassis from a rack, use the following steps:

1. Extend the slides as shown in [Figure 4-21](#).

CHASSIS REMOVAL – EXTEND SLIDES

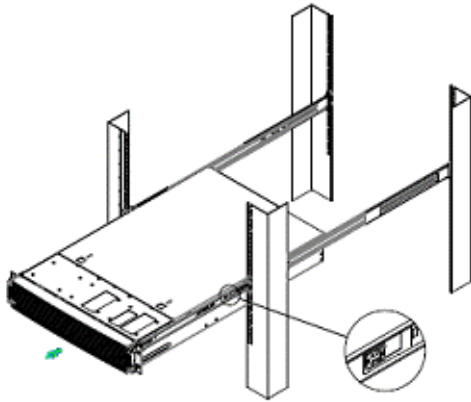

Fully extend the slides until it is in the locked position, pull the release button to release lock and disconnect inner member from slides.

Figure 4-21 Extending Slides to Remove the Chassis

2. Remove the inner members from the chassis as shown in [Figure 4-22](#).

CHASSIS REMOVAL – REMOVE INNER MEMBER FROM CHASSIS



Figure 4-22 Removing the Inner Member from the Chassis

Power and Environmental Specifications

This appendix describes the following:

- “Power Rating” on page 45
- “Wattage Limitation of the PCI Loading” on page 46
- “Environmental Specifications” on page 46

Power Rating

Table A-1 summarizes the power rating of the power supply.

Table A-1 Power Rating of the Power Supply

VIN	Total Available Power
100~127VAC (AC low-line)	1120W
200~240VAC (AC high-line)	1600W

Wattage Limitation of the PCI Loading

Table A-2 summarizes the wattage limitation of the PCI loading.

Table A-2 Wattage Limitation of the PCIe Loading

VIN	Power Supply Configuration	Maximum PCI Loading
90–140VAC (AC low-line)	1600W (1+1) redundant, hot-swap capable 1600W (1+0 or 2+0) non-redundant	260W
180–264VAC (AC high-line)	1600W (1+1) redundant, hot-swap capable 1600W (1+0 or 2+0) non-redundant	450W

Environmental Specifications

Table A-3 lists the system-level operation and non-operating environmental limits.

Table A-3 Environmental Specifications

Attribute	Limits
Operating temperature	+10°C to +35°C with the maximum rate of change not to exceed 10°C per hour
Non-operating temperature	-40°C to +70°C
Operating humidity range	20%–80%, non-condensing
Non-operating humidity	8%–80%, non-condensing at 35°C
Acoustic noise	Sound power: – 3.5” HDD SKU: 6.9BA at idle and 7.4BA at active mode – 2.5” HDD SKU: 6.5BA at idle and 7.07BA at active mode.
Shock, operating	Half sine, 2 g peak, 11 milliseconds
Shock, unpackaged	Trapezoidal, 25 g, velocity change 136 inches/second (40 lbs to less than 80 lbs)
Shock, packaged	Non-palletized free fall in height 24 inches (40 lbs to less than 80 lbs)
Vibration, unpackaged	5 Hz to 500 Hz, 2.20 g RMS random

Table A-3 Environmental Specifications (continued)

Attribute	Limits
ESD	+/-12 KV, except I/O port +/- 8 KV per test specification
System cooling requirement in BTU/Hr	1200 Watt Max – 4095 BTU/hour 1600 Watt Max – 5459 BTU/hour

Regulatory Compliance Information

Table B-1 summarizes the product regulatory compliance.

Table B-1 Product Regulatory Compliance

Category	Compliance Information
Electromagnetic Emissions	FCC Class A, EN 55022 Class A, EN 61000-3-2/-3-3, CISPR 22 Class A
Electromagnetic Immunity	EN 55024/CISPR 24, (EN 61000-4-2, EN 61000-4-3, EN 61000-4-4, EN 61000-4-5, EN 61000-4-6, EN 61000-4-8, EN 61000-4-11)
Safety	CSA/EN/IEC/UL 60950-1 Compliant, UL or CSA Listed (USA and Canada), CE Marking (Europe)
Perchlorate Materials	California Best Management Practices Regulations for Perchlorate Materials: "This Perchlorate warning applies only to products containing CR (Manganese Dioxide) Lithium coin cells. Special handling for perchlorate material may apply. See www.dtsc.ca.gov/hazardouswaste/perchlorate ."

Rail Kit Installation

If the chassis for your server does not have pre-installed rail slides, SGI provides a rail kit. Use the following steps to install the rail kit.

1. Attach the slide rails to the racks as shown in [Figure C-1](#).

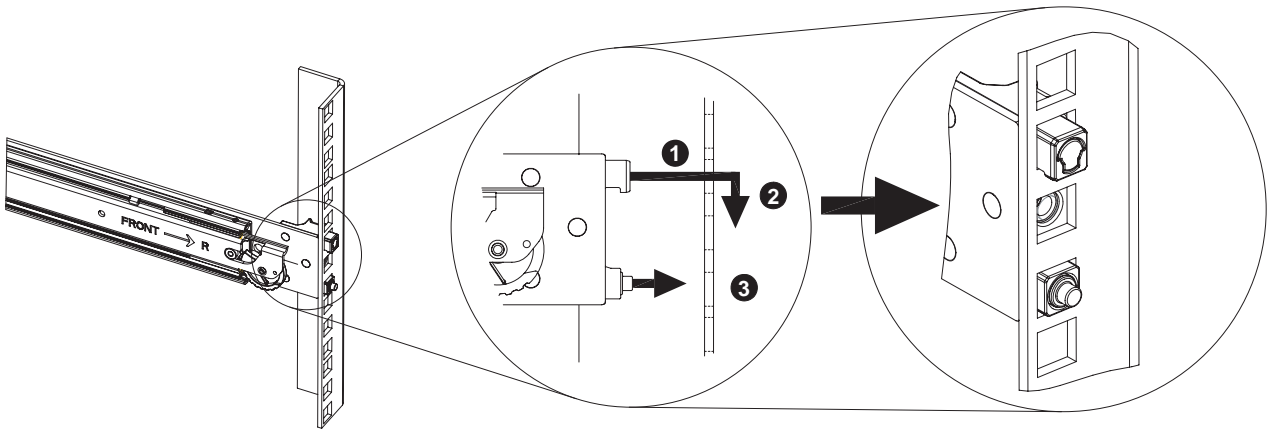

Figure C-1 Attaching Rail Slides to Rack

2. Fully extend the rail slides as shown in Figure C-2.

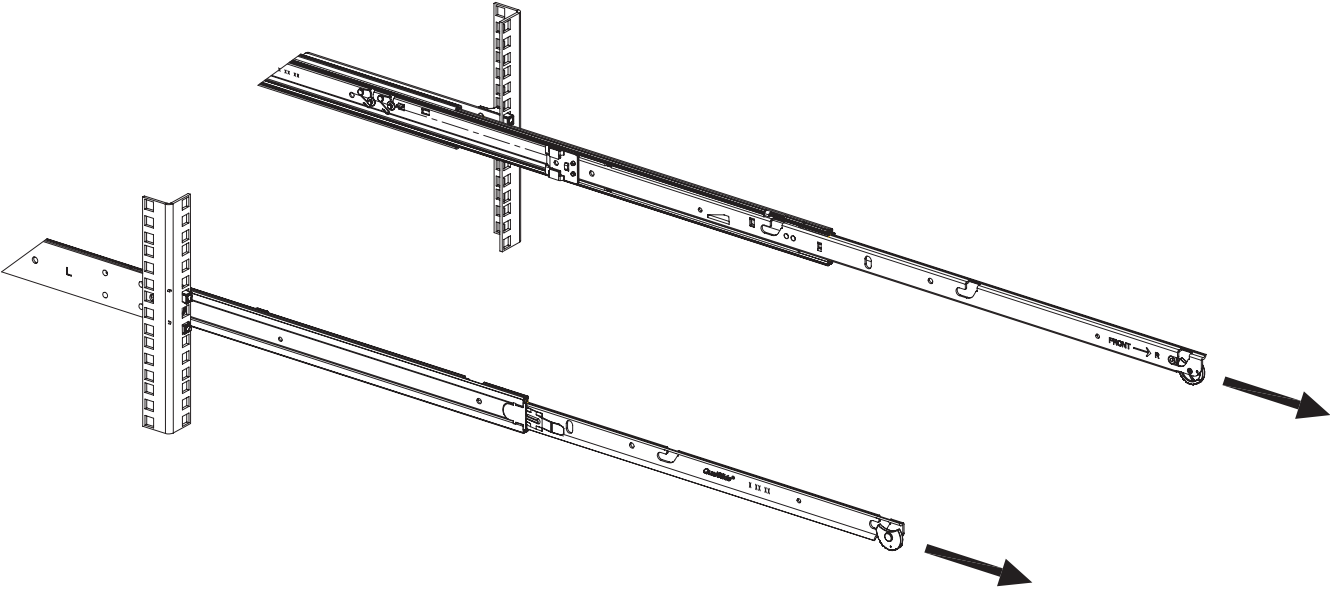

Figure C-2 Extending Rail Slides

3. Attach the chassis to the rail slides as shown in [Figure C-3](#).

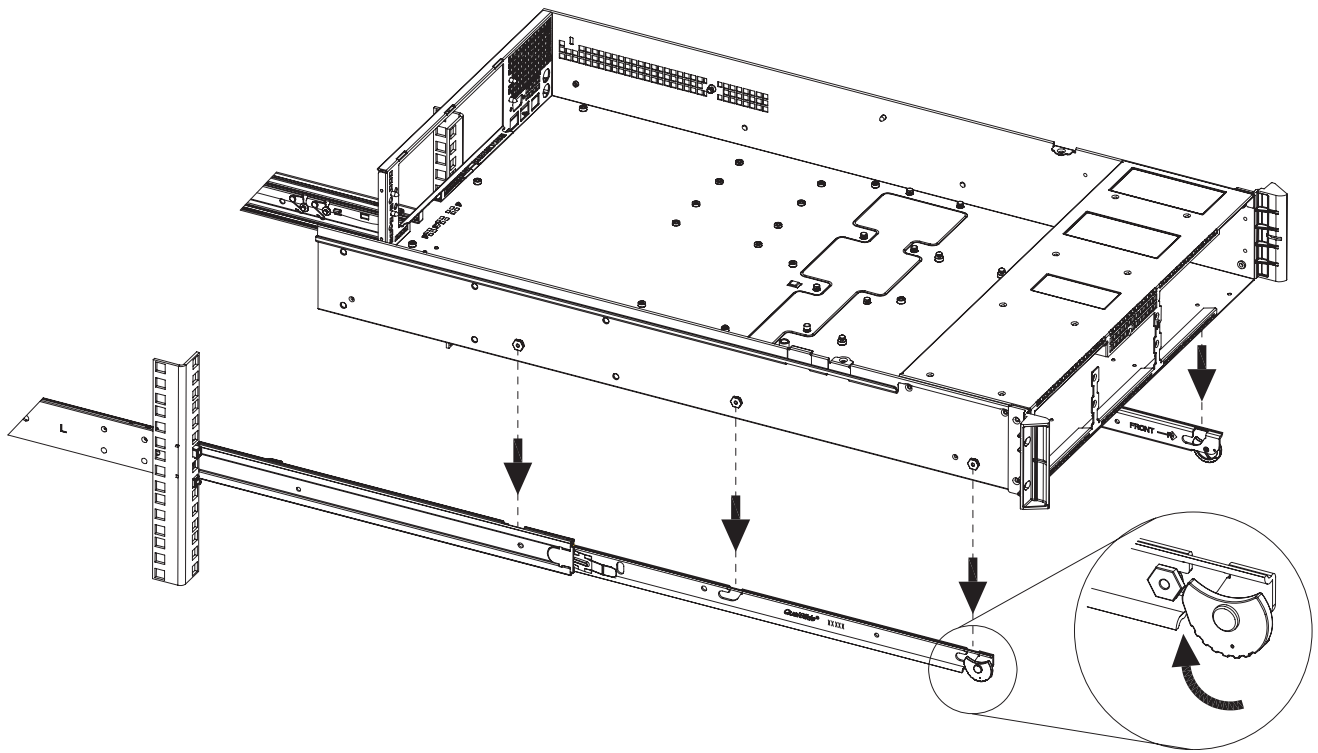

Figure C-3 Attaching Chassis to Rail Slides

4. Push the release tab and push the chassis into the rack as shown in Figure C-4.

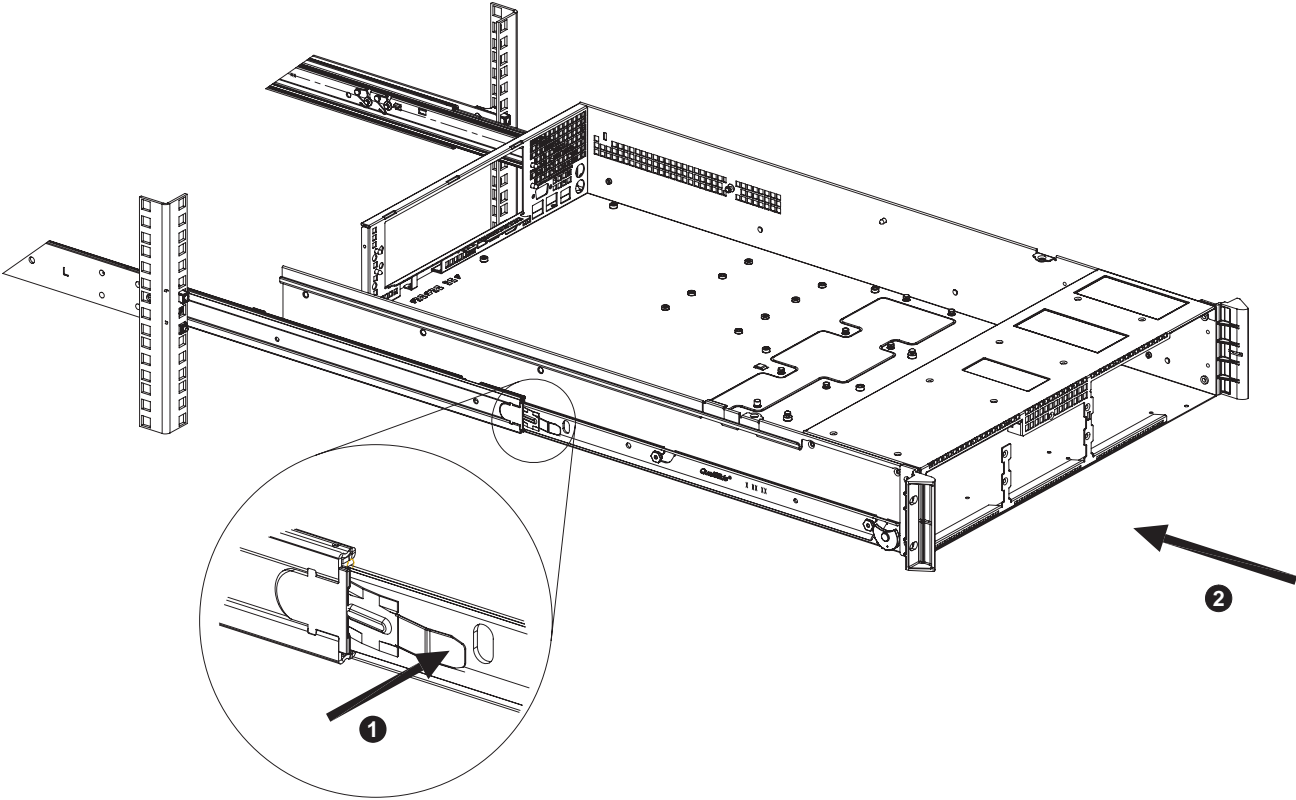

Figure C-4 Rail Slide Release Tab

BMC Error Codes

The BMC may generate beep codes upon detection of failure conditions. Beep codes are sounded each time the problem is discovered (for example, on each power-up attempt) but are not sounded continuously. Common supported codes are listed in [Table D-1](#).

In [Table D-1](#), each digit in the code is represented by a sequence of beeps whose count is equal to the digit.

Table D-1 BMC Beep Codes

Beep Code	Reason for Beep	Associated Sensors	Supported
1-5-2-1	No CPUs installed or first CPU socket is empty.	CPU Missing sensor	Yes
1-5-2-4	MSID Mismatch.	MSID Mismatch sensor.	Yes
1-5-4-2	Power fault: DC power is unexpectedly lost (power good dropout).	Power unit—power unit failure offset.	Yes
1-5-4-4	Power control fault (power good assertion timeout).	Power unit—soft power control failure offset.	Yes
1-5-1-2	VR Watchdog Timer sensor assertion	VR Watchdog timer	
1-5-1-4	The system does not power on or unexpectedly powers off and a power supply unit (PSU) is present that is an incompatible model with one or more other PSUs in the system.	PSU status	

